

MB39C326-EVBSK-01/02

**Small size Evaluation Board of 6MHz Buck-boost
DC/DC Converter IC**

Operation Manual



Preface

This manual explains how to use the evaluation board. Be sure to read this manual before using the product. For this product, please consult with sales representatives or support representatives.

Handling and use

Handling and use of this product and notes regarding its safe use are described in the manuals.

Follow the instructions in the manuals to use this product.

Keep this manual at hand so that you can refer to it anytime during use of this product.

Notice on this document

All information included in this document is current as of the date it is issued. Such information is subject to change without any prior notice.

Please confirm the latest relevant information with the sales representatives.

Caution of the products described in this document

The following precautions apply to the product described in this manual.

 WARNING	Indicates a potentially hazardous situation which could result in death or serious injury and/or a fault in the user's system if the product is not used correctly.
--	---

Electric shock, Damage	Before performing any operation described in this manual, turn off all the power supplies to the system. Performing such an operation with the power on may cause an electric shock or device fault.
Electric shock, Damage	Once the product has been turned on, do not touch any metal part of it. Doing so may cause an electric shock or device fault.

 CAUTION	Indicates the presence of a hazard that may cause a minor or moderate injury, damages to this product or devices connected to it, or may cause to loose software resources and other properties such as data, if the device is not used appropriately.
--	--

Cuts, Damage	Before moving the product, be sure to turn off all the power supplies and unplug the cables. Watch your step when carrying the product. Do not use the product in an unstable location such as a place exposed to strong vibration or a sloping surface. Doing so may cause the product to fall, resulting in an injury or fault.
Cuts	The product contains sharp edges that are left unavoidably exposed, such as jumper plugs. Handle the product with due care not to get injured with such pointed parts.
Damage	Do not place anything on the product or expose the product to physical shocks. Do not carry the product after the power has been turned on. Doing so may cause a malfunction due to overloading or shock.
Damage	Since the product contains many electronic components, keep it away from direct sunlight, high temperature, and high humidity to prevent condensation. Do not use or store the product where it is exposed to much dust or a strong magnetic or electric field for an extended period of time. Inappropriate operating or storage environments may cause a fault.
Damage	Use the product within the ranges given in the specifications. Operation over the specified ranges may cause a fault.
Damage	To prevent electrostatic breakdown, do not let your finger or other object come into contact with the metal parts of any of the connectors. Before handling the product, touch a metal object (such as a door knob) to discharge any static electricity from your body.
Damage	When turning the power on or off, follow the relevant procedure as described in this document. Before turning the power on, in particular, be sure to finish making all the required connections. Furthermore, be sure to configure and use the product by following the instructions given in this document. Using the product incorrectly or inappropriately may cause a fault.
Damage	Because the product has no casing, it is recommended that it be stored in the original packaging. Transporting the product may cause a damage or fault. Therefore, keep the packaging materials and use them when re-shipping the product.

Table of Contents

1. Description	5
2. Evaluation Board Specification	5
3. Block Diagram	6
4. PIN Descriptions	8
4.1 Input/Output Pin Descriptions	8
4.2 Jumper Descriptions	8
4.3 Setup and Verification	8
5. Component and Wiring Layout	9
5.1 Component Layout	9
5.2 Wiring Layout	11
6. Schematic Circuit	12
7. Component List	14
8. Evaluation Board Picture	15
9. Ordering Information	16
10. Major Changes	17

Figures

Figure 1-1 Board Outline	5
Figure 3-1 Block Diagram for EVBSK-01	6
Figure 3-2 Block Diagram for EVBSK-02	7
Figure 4-1 Image of Connection	8
Figure 5-1 Component Layout (Layer 1)	9
Figure 5-2 Component Layout (Layer 2, Top View)	10
Figure 5-3 Wiring Layout (Layer 1)	11
Figure 5-4 Wiring Layout (Layer 2, Top View)	11
Figure 6-1 Schematic Circuit for Power Save Mode	12
Figure 6-2 Schematic Circuit for Fixed PWM Mode	13
Figure 8-1 Picture of MB39C326-EVBSK-01	15
Figure 8-2 Picture of MB39C326-EVBSK-02	15

Tables

Table 2-1 Evaluation Board Specification	5
Table 4-1 Input/Output Pin Descriptions	8
Table 4-2 Jumper Descriptions	8
Table 7-1 Component List	14
Table 9-1 Ordering Information	16

MB39C326-EVB-01/02

Small size Evaluation Board of 6MHz Buck-boost DC/DC converter IC

Operation Manual



1. Description

The MB39C326-EVBSK-01/02 is the small size evaluation board for the 6MHz Buck-boost DC/DC converter IC, MB39C326. This evaluation board output preset 3.3V or can be selected the other values by DAC signal input. The board consists of simple two layers. Two different function of boards lineup : MB39C326-EVBSK-01 for power save mode and MB39C326-EVBSK-02 for fixed PWM.

Figure 1-1 Board Outline

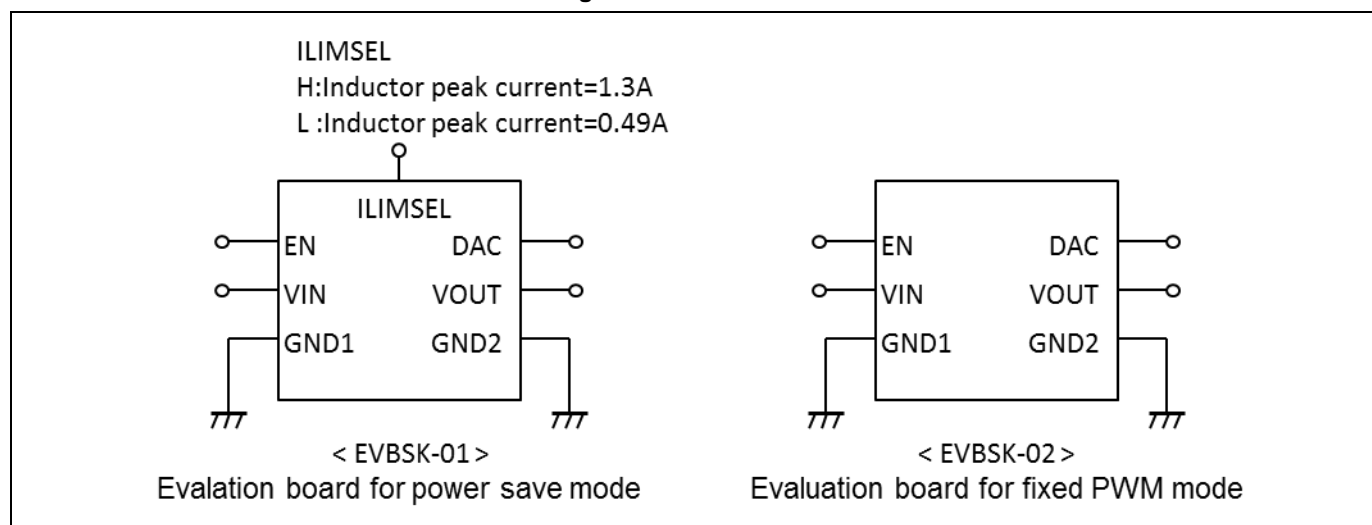

2. Evaluation Board Specification

Table 2-1 Evaluation Board Specification

Item	Symbol	Condition	Min	Typ	Max	Unit
Input voltage	VIN	-	2.5	3.7	5.5	V
Output voltage	VOUT	R1 = 620 kΩ, R2 = 110 kΩ	3.185	3.318	3.451	V
Output current	IOUT(MAX1)	VIN = 3.3V to 5.5V, EVBSK-02	-	-	1200	mA
	IOUT(MAX2)	VIN = 2.5V to 3.3V, EVBSK-02	-	-	800	mA
	IOUT(MAX3)	VIN = 3.3V to 5.5V, EVBSK-01, ILIMSEL = H	-	-	600	mA
	IOUT(MAX4)	VIN = 2.5V to 3.3V, EVBSK-01, ILIMSEL = H	-	-	500	mA
Switching frequency	FREQUENCY	-	5.2	5.8	6.4	MHz
Maximum efficiency	EFFICIENCY	-	-	93	-	%
Signal input threshold voltage	VIL	EN, ILIMSEL	0.0	-	0.25	V
	VIH		1.5	-	VIN	V

Board size: 12.7 mm × 7.62 mm, Component height 1mm max

3. Block Diagram

Figure 3-1 Block Diagram for EVBSK-01

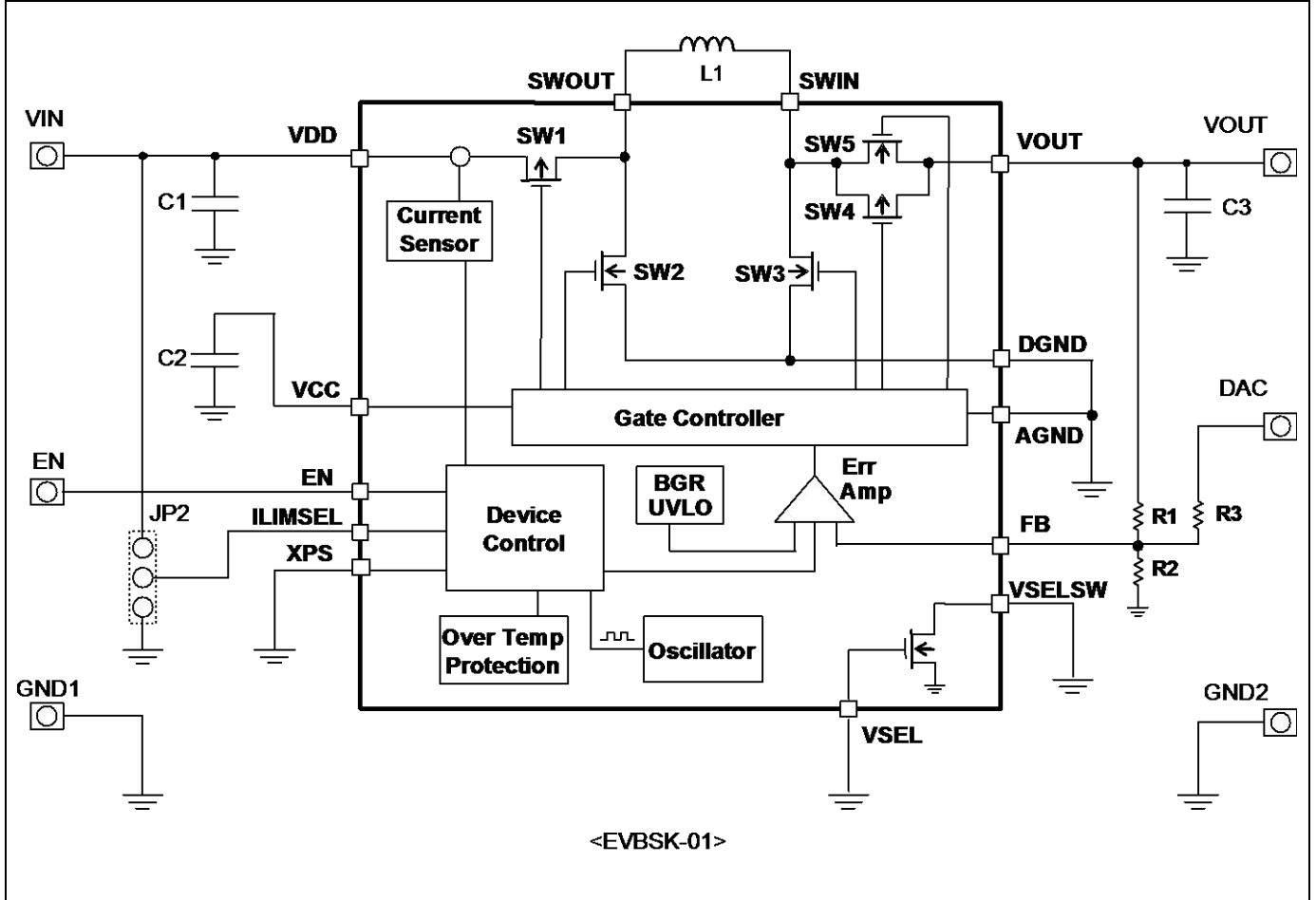
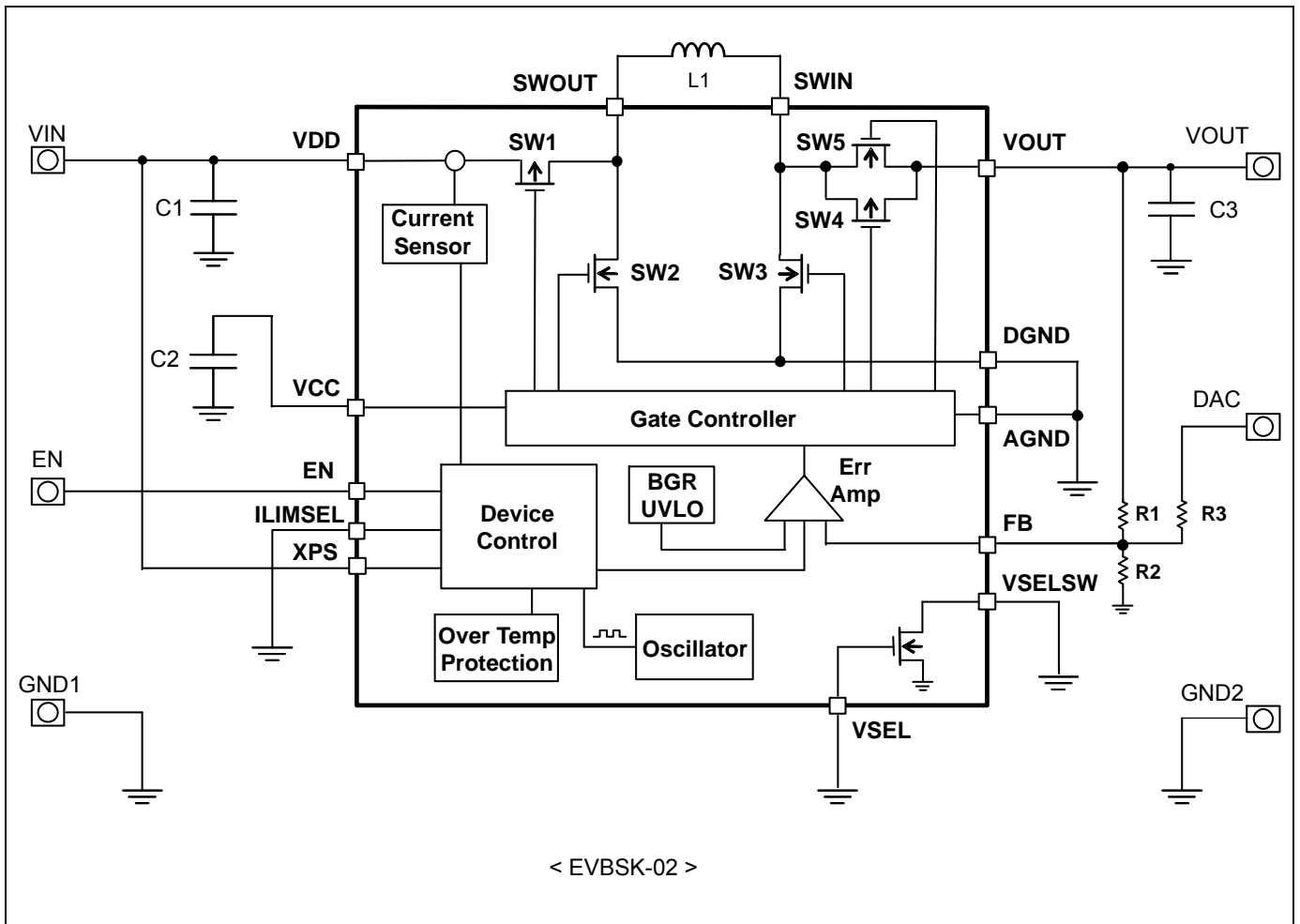

Figure 3-2 Block Diagram for EVBSK-02



4. PIN Descriptions

4.1 Input/Output Pin Descriptions

Table 4-1 Input/Output Pin Descriptions

Terminal	I/O	Description
VIN	I	Power supply terminal
VOUT	O	Output terminal
EN	I	IC enable terminal EN = H : Enable EN = L : Shutdown
DAC	I	Output voltage setting terminal (DAC signal input)(*1)
ILIMSEL	I	Inductor peak current select terminal (EVBSK-01)(*2) ILIMSEL = H : Inductor peak current value(I _{PK})= 1.3A ILIMSEL = L : Inductor peak current value(I _{PK})= 0.49A
GND1	-	Input GND terminal
GND2	-	Output GND terminal

*1: Please refer the MB39C326 datasheet for setting output voltage by DAC.

*2: EVBSK-01: MB39C326 XPS pin is set to L, ILIMSEL pin is set to H and output current limit value(I_{PK}) = 1.3A at ILIMSEL = H and 0.49A at ILIMSEL = L.

EVBSK-02: MB39C326 XPS pin is set to H, ILIMSEL pin is set to L and inductor peak current value(I_{PK}) = 3.2A.

4.2 Jumper Descriptions

Table 4-2 Jumper Descriptions

Jumper	Description	Initial
JP2	H: MB39C326 ILIMSEL pin is short to VIN. (L) : MB39C326 ILIMSEL pin is shorted to GND.	Short to VIN

4.3 Setup and Verification

1. Connect the power supply between VIN and GND1. EN is connected to VIN.
2. 3.3V is output to VOUT terminal after power is supplied.

Low impedance power supply is recommended to use. The power supply line can be stable at evaluation when some capacitor is connected to the line.

Figure 4-1 Image of Connection

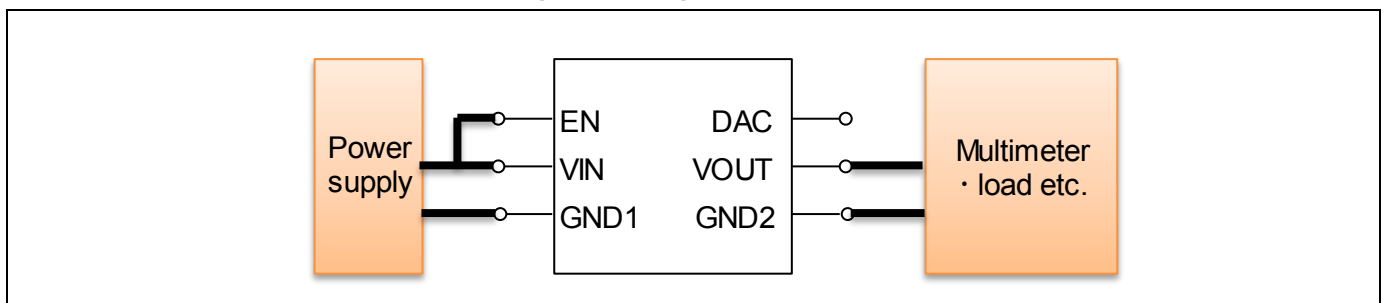

5. Component and Wiring Layout

5.1 Component Layout

Figure 5-1 Component Layout (Layer 1)

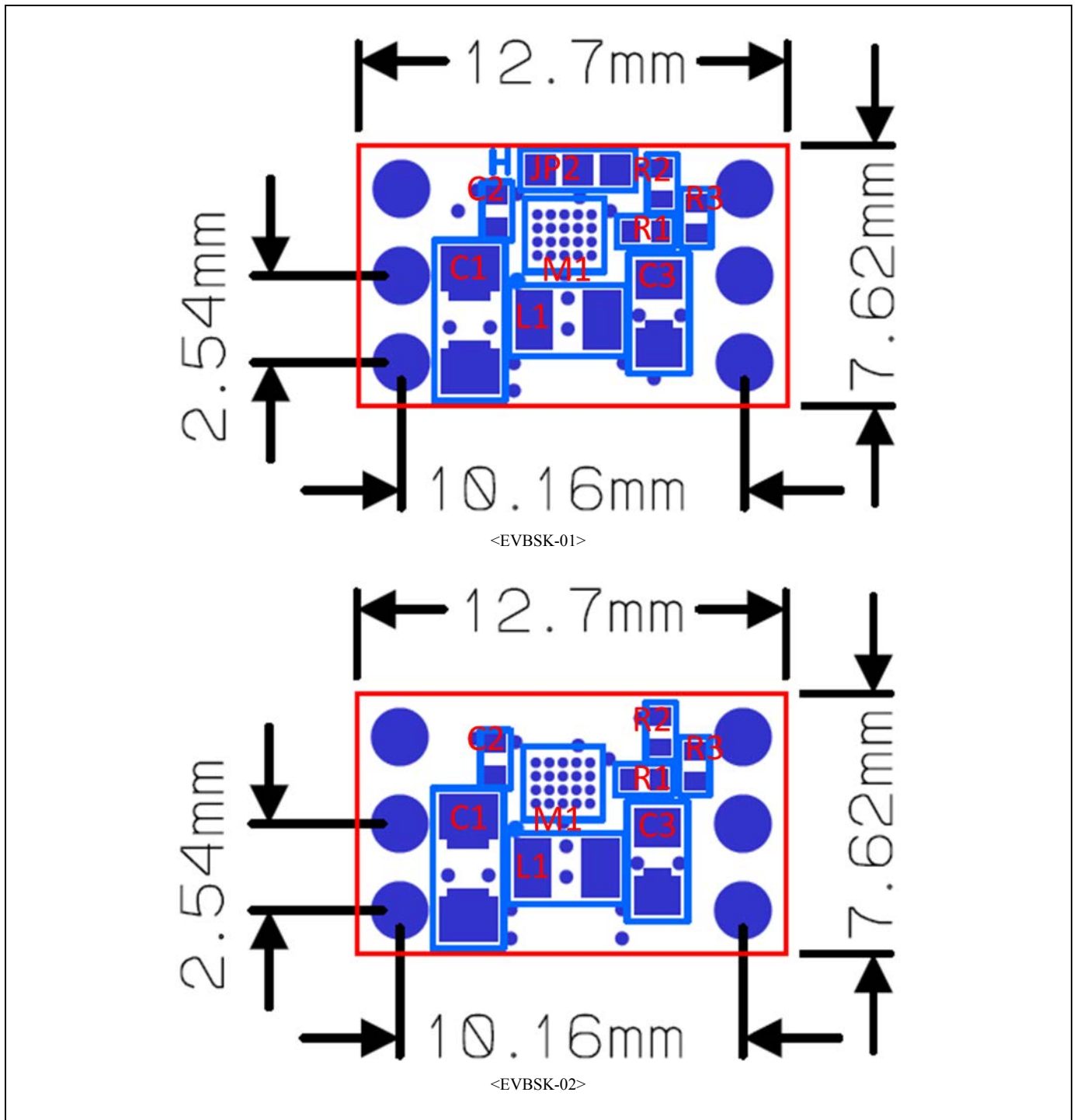
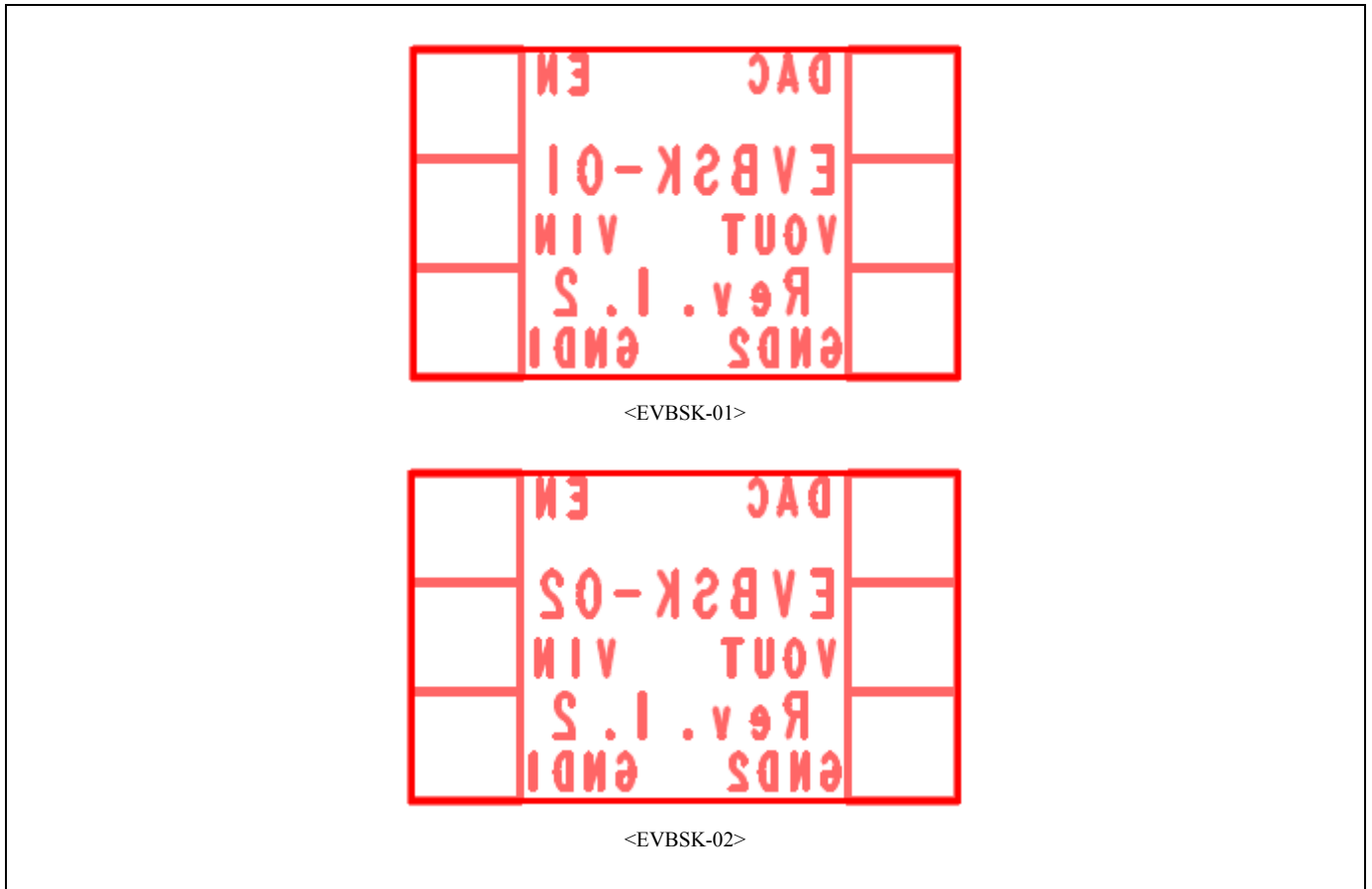

Figure 5-2 Component Layout (Layer 2, Top View)



5.2 Wiring Layout

Figure 5-3 Wiring Layout (Layer 1)

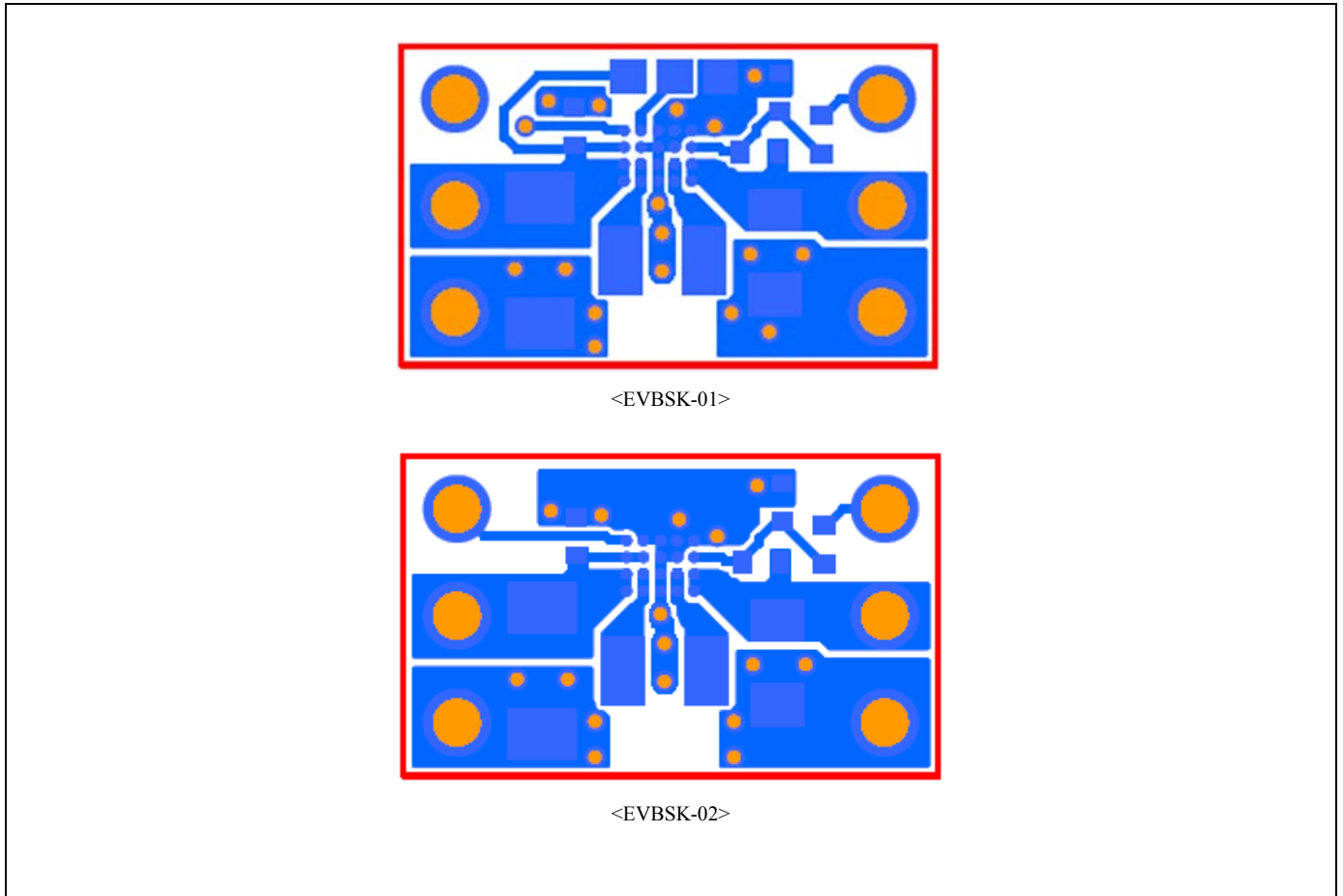
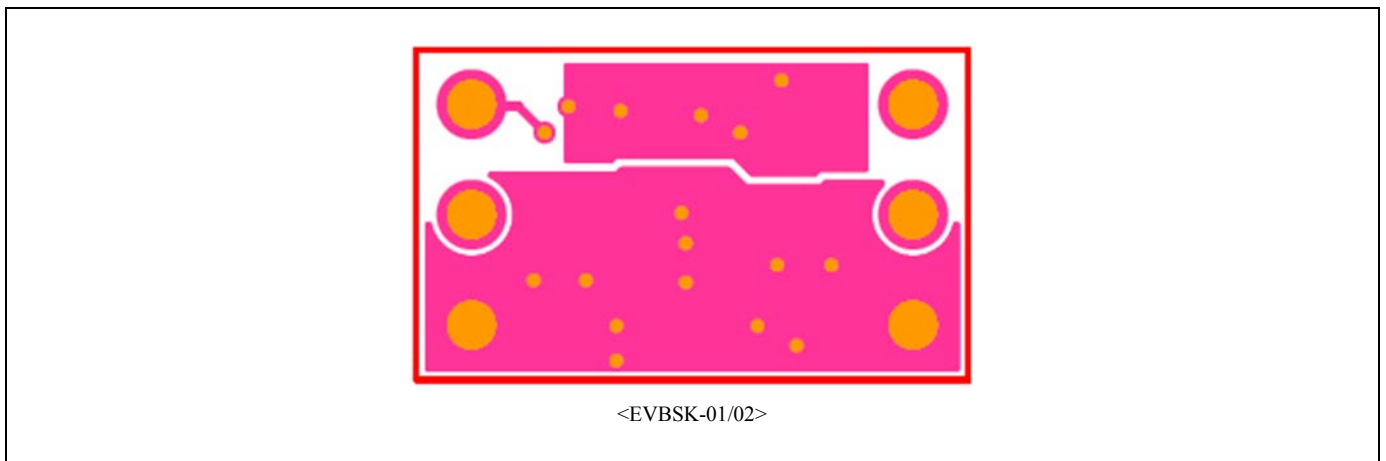

Figure 5-4 Wiring Layout (Layer 2, Top View)



6. Schematic Circuit

Figure 6-1 Schematic Circuit for Power Save Mode

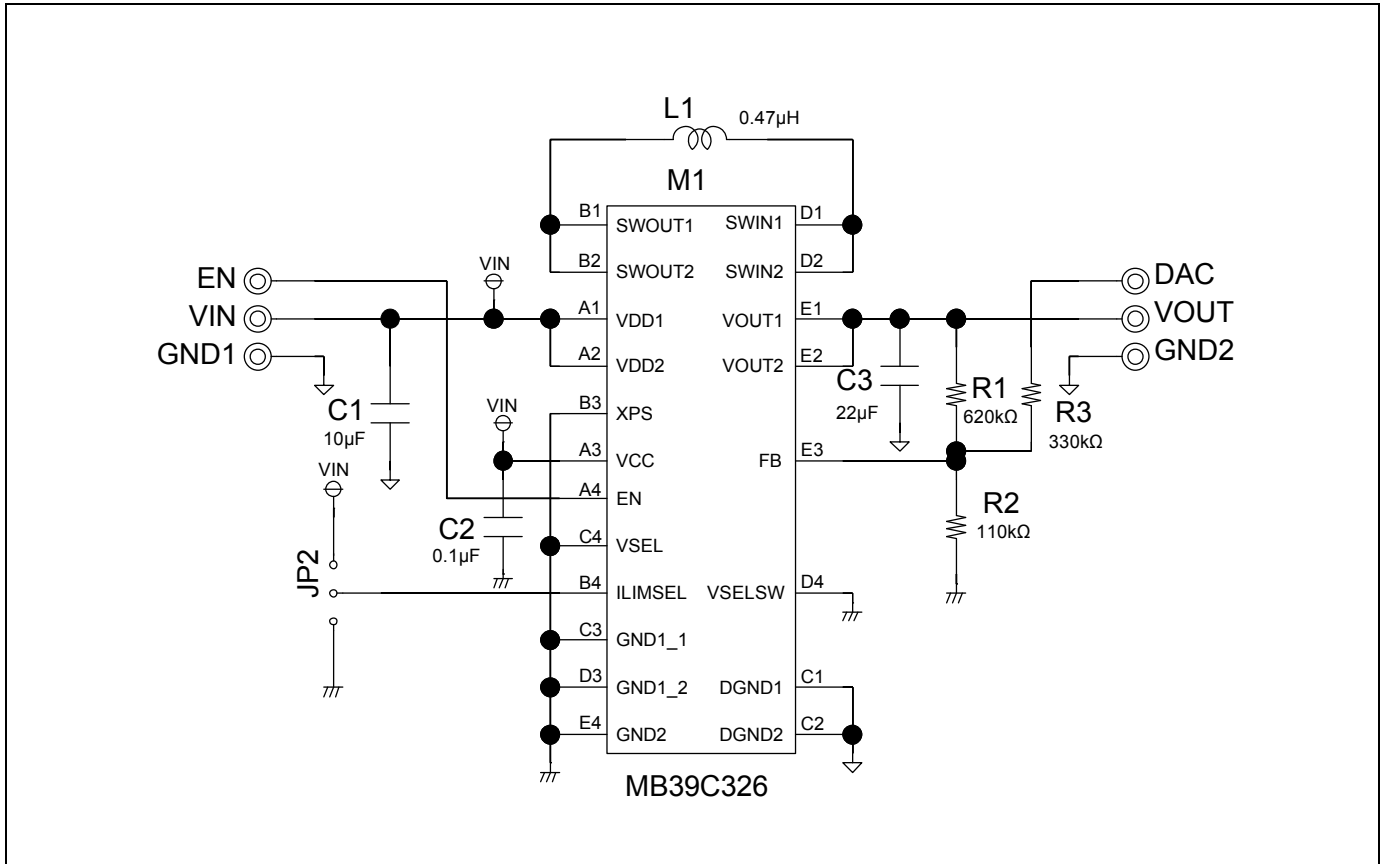
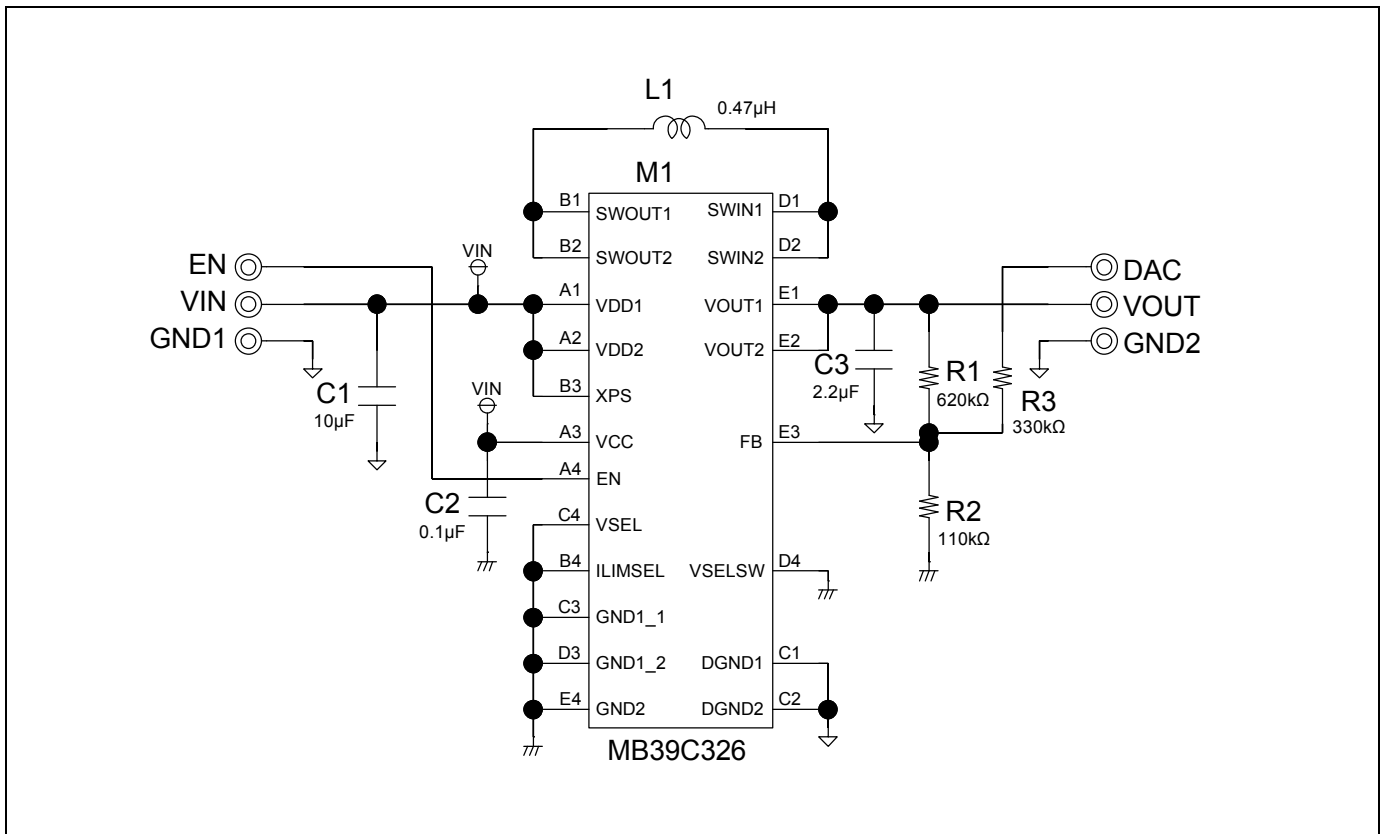

Figure 6-2 Schematic Circuit for Fixed PWM Mode



7. Component List

Table 7-1 Component List

No.	Component	Item	Parts Number	Vendor	Value	Remarks
1	M1	PMIC	MB39C326	Cypress	-	
2	L1	Inductor	GLCHKR4701A	ALPS	0.47 μ H	35 m Ω , 3.7A
3	C1	Ceramic Capacitor	EMK107BBJ106MA-T	TAIYO YUDEN	10 μ F	16V, X5R, 1608
4	C2	Ceramic Capacitor	UMK105BJ104KV-F	TAIYO YUDEN	0.1 μ F	50V, X5R, 1005
5	C3	Ceramic Capacitor	EMK105ABJ225MV-F	TAIYO YUDEN	2.2 μ F	16V, X5R, 1005, EVBSK-02
		Ceramic Capacitor	JMK107BBJ226MA-T	TAIYO YUDEN	22 μ F(*1)	6.3V, X5R, 1608, EVBSK-01
6	R1	Chip Resistor	RK73H1ETTP6203F	KOA	620 k Ω	\pm 1.0%
7	R2	Chip Resistor	RK73H1ETTP1103F	KOA	110 k Ω	\pm 1.0%
8	R3	Chip Resistor	RK73H1ETTP3303F	KOA	330 k Ω	\pm 1.0%
9	JP2	Solder jumper	JPPAD	-	-	H (Short to VIN)

Cypress : Cypress Semiconductor Corp.

ALPS : Alps Green Devices Co., Ltd

TAIYO YUDEN : Taiyo Yuden Co., LTD

KOA : KOA Corporation

These components are compliant with RoHS. Please ask each vendor for details if necessary.

*1: EVBSK-01 operates by PFM mode at light load. Large output capacitor (around 22 μ F) is recommended to reduce the output ripple voltage.

8. Evaluation Board Picture

Figure 8-1 Picture of MB39C326-EVBSK-01

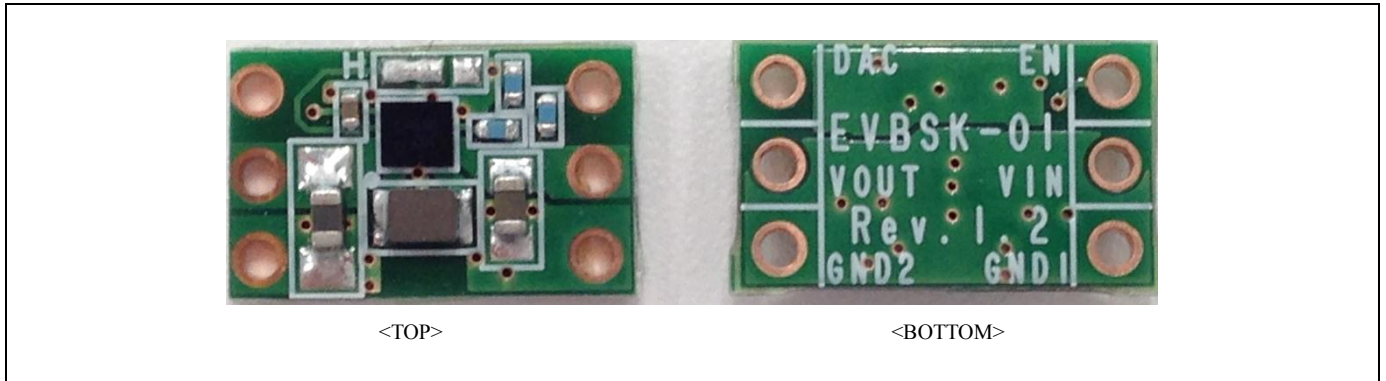
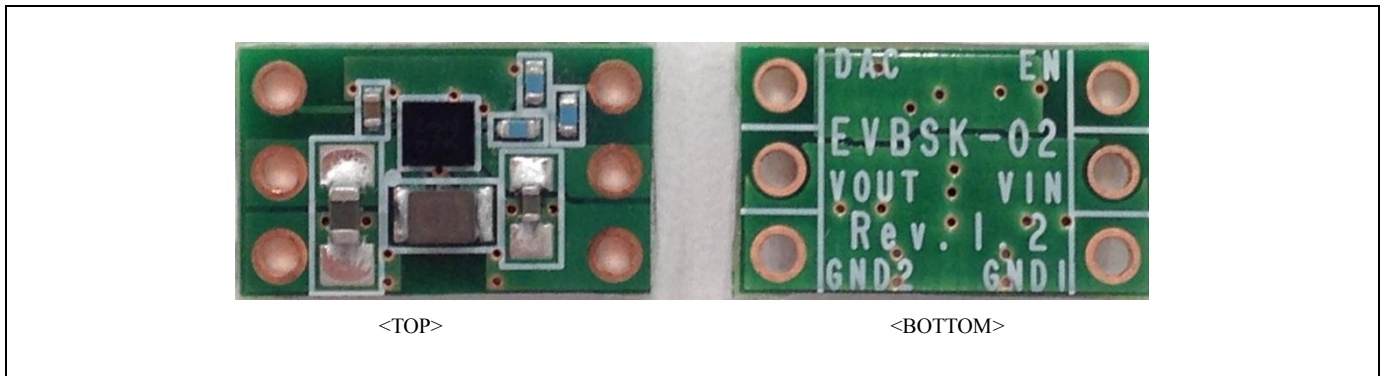

Figure 8-2 Picture of MB39C326-EVBSK-02



9. Ordering Information

Table 9-1 Ordering Information

Part Number	EVB Revision	Note
MB39C326-EVBSK-01	Rev 1.2	---
MB39C326-EVBSK-02	Rev 1.2	---

10. Major Changes

Page	Section	Change Results
Revision 1.0		
-	-	Initial release
Revision 2.0		
14	7. Component List	Revised the Component of Component list GLC series → GLCHKR4701A
15	8. Evaluation Board Picture	Inserted board pictures



SS901-00022-2v0-E

Cypress • Operation Manual

MB39C326-EVBSK-01/02
Evaluation Board of 6MHz Buck-boost DC/DC Converter IC
Operation Manual

June 2015 Rev. 2.0

Published: Cypress Semiconductor Corp.
Edited: Communications

Colophon

The products described in this document are designed, developed and manufactured as contemplated for general use, including without limitation, ordinary industrial use, general office use, personal use, and household use, but are not designed, developed and manufactured as contemplated (1) for any use that includes fatal risks or dangers that, unless extremely high safety is secured, could have a serious effect to the public, and could lead directly to death, personal injury, severe physical damage or other loss (i.e., nuclear reaction control in nuclear facility, aircraft flight control, air traffic control, mass transport control, medical life support system, missile launch control in weapon system), or (2) for any use where chance of failure is intolerable (i.e., submersible repeater and artificial satellite). Please note that Cypress will not be liable to you and/or any third party for any claims or damages arising in connection with above-mentioned uses of the products. Any semiconductor devices have an inherent chance of failure. You must protect against injury, damage or loss from such failures by incorporating safety design measures into your facility and equipment such as redundancy, fire protection, and prevention of over-current levels and other abnormal operating conditions. If any products described in this document represent goods or technologies subject to certain restrictions on export under the Foreign Exchange and Foreign Trade Law of Japan, the US Export Administration Regulations or the applicable laws of any other country, the prior authorization by the respective government entity will be required for export of those products.

Trademarks and Notice

The contents of this document are subject to change without notice. This document may contain information on a Cypress product under development by Cypress. Cypress reserves the right to change or discontinue work on any product without notice. The information in this document is provided as is without warranty or guarantee of any kind as to its accuracy, completeness, operability, fitness for particular purpose, merchantability, non-infringement of third-party rights, or any other warranty, express, implied, or statutory. Cypress assumes no liability for any damages of any kind arising out of the use of the information in this document.

Copyright © 2014-2015 Cypress Semiconductor Corp. All rights reserved. Cypress, the Cypress logo, Spansion[®], the Spansion logo, MirrorBit[®], MirrorBit[®] Eclipse[™], ORNAND[™], Easy DesignSim[™], Traveo[™] and combinations thereof, are trademarks and registered trademarks of Cypress Semiconductor Corp. in the United States and other countries. Other names used are for informational purposes only and may be trademarks of their respective owners.

X-ON Electronics

Largest Supplier of Electrical and Electronic Components

Click to view similar products for [Adhesive Tapes](#) category:

Click to view products by [Cypress](#) manufacturer:

Other Similar products are found below :

[PF24.0W](#) [4718](#) [4516-1/4x36](#) [56-YELLOW-34"X72YD](#) [00-021200-13972-7](#) [021200-64630](#) [60 TAPE \(1"\)](#) [62-GRAY-1"X36YD](#) [69-1"X36YD](#) [764-1"x36yd-Red](#) [764-1"x36yd-White](#) [PG ASSY](#) [926-1/4X18YD](#) [967454-1](#) [1194-14"X36YD](#) [1181 19MM X 16,5 METERS](#) [1182-7.7X10](#) [1245-34"X18YD](#) [1267](#) [130C-1X15FT](#) [130-1x10FT](#) [1345-3/8x18yrd](#) [1380-2"X8"](#) [E39-RS1-CA](#) [1900-48mm](#) [22-1/2X36YD](#) [2229-P-2-1/2x3-3/4](#) [88-SUPER-34X44FT](#) [890103N001](#) [2670](#) [SJ3527N-Black-1.5"x50yd](#) [EVK-TA-TM047NBH01](#) [AD-UCUSB-DCAUD-SPL](#) [20-1"X60YDS](#) [2020-18mmx55m](#) [H150](#) [3900-Blue](#) [3939-24mmx55m](#) [396-1"x36yd](#) [4016-34"x36yd](#) [4462W-12"x72yd](#) [44-TAN-14"X90YD](#) [4504-34x18](#) [471-Trans-1"x36yd-Bulk](#) [5414 34X36](#) [C-22](#) [35-Gray-1/2](#) [371-Tan-48mmx50m](#) [4008-12"X36YD](#) [4104-34"x18yd](#)