

4MHz, High Supply Voltage Operational Amplifiers

HA-2640 and HA-2645 are monolithic operational amplifiers which are designed to deliver unprecedented dynamic specifications for a high voltage internally compensated device. These dielectrically isolated devices offer very low values for offset voltage and offset current coupled with large output voltage swing and common mode input voltage.

For maximum reliability, these amplifiers offer unconditional output overload protection through current limiting and a chip temperature sensing circuit. This sensing device turns the amplifier "off", when the chip reaches a certain temperature level.

These amplifiers deliver $\pm 35V$ common mode input voltage range, $\pm 35V$ output voltage swing, and up to $\pm 40V$ supply range for use in such designs as regulators, power supplies, and industrial control systems. 4MHz gain bandwidth and $5V/\mu s$ slew rate make these devices excellent components for high performance signal conditioning applications. Outstanding input and output voltage swings coupled with a low 5nA offset current make these amplifiers excitation designs.

Features

- Output Voltage Swing $\pm 35V$
- Supply Voltage $\pm 10V$ to $\pm 40V$
- Offset Current. 5nA
- Bandwidth 4MHz
- Slew Rate. $5V/\mu s$
- Common Mode Input Voltage Range. $\pm 35V$
- Output Overload Protection

Applications

- Industrial Control Systems
- Power Supplies
- High Voltage Regulators
- Resolver Excitation
- Signal Conditioning

Ordering Information

PART NUMBER	PART MARKING	TEMP. RANGE (°C)	PACKAGE	PKG. DWG. #
HA2-2640-2	HA2-2640-2	-55 to 125	8 Pin Metal Can	T8.C
HA7-2640-2	HA7-2640-2	-55 to 125	8 Ld CERDIP	F8.3A
HA2-2645-5	HA2-2645-5	0 to 75	8 Pin Metal Can	T8.C
HA7-2645-5	HA7-2645-5	0 to 75	8 Ld CERDIP	F8.3A

Pinouts

**HA-2640/2645
(CERDIP)
TOP VIEW**

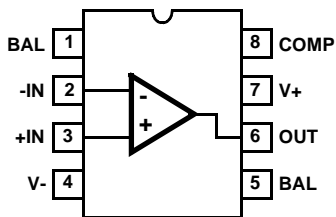

**HA-2640/2645
(METAL CAN)
TOP VIEW**

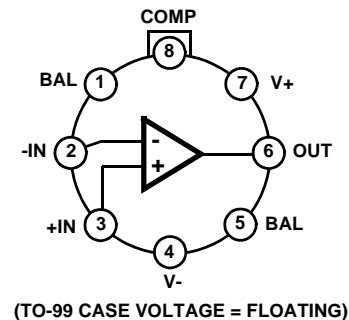

HA-2640, HA-2645

Absolute Maximum Ratings

Voltage Between V+ and V- Terminals 100V
 Differential Input Voltage Range 37V
 Output Current Full Short Circuit Protection

Operating Conditions

Temperature Range
 HA-2640-2 -55°C to 125°C
 HA-2645-5 0°C to 75°C

Thermal Information

Thermal Resistance (Typical, Note 1) θ_{JA} (°C/W) θ_{JC} (°C/W)
 CERDIP Package 135 50
 Metal Can Package 165 80
 Maximum Junction Temperature 175°C
 Maximum Storage Temperature Range -65°C to 150°C
 Maximum Lead Temperature (Soldering 10s) 300°C

CAUTION: Stresses above those listed in "Absolute Maximum Ratings" may cause permanent damage to the device. This is a stress only rating and operation of the device at these or any other conditions above those indicated in the operational sections of this specification is not implied.

NOTE:

- θ_{JA} is measured with the component mounted on an evaluation PC board in free air.

Electrical Specifications $V_{SUPPLY} = \pm 40V$, $R_L = 5k\Omega$, Unless Otherwise Specified

PARAMETER	TEST CONDITIONS	TEMP (°C)	HA-2640-2			HA-2645-5			UNITS
			MIN	TYP	MAX	MIN	TYP	MAX	
INPUT CHARACTERISTICS									
Offset Voltage		25	-	2	4	-	2	6	mV
		Full		-	6	-	-	7	mV
Average Offset Voltage Drift		Full	-	15	-	-	15	-	$\mu V/^\circ C$
Bias Current		25	-	10	25	-	12	30	nA
		Full	-	-	50	-	-	50	nA
Offset Current		25	-	5	12	-	15	30	nA
		Full	-	-	35	-	-	50	nA
Input Resistance (Note 2)		25	50	250	-	40	200	-	M Ω
Common Mode Range		Full	± 35	-	-	± 35	-	-	V
TRANSFER CHARACTERISTICS									
Large Signal Voltage Gain	$V_{OUT} = \pm 30V$	25	100	200	-	100	200	-	kV/V
		Full	75	-	-	75	-	-	-
Common Mode Rejection Ratio	$V_{CM} = \pm 20V$	Full	80	100	-	74	100	-	dB
Minimum Stable Gain		25	1	-	-	1	-	-	V/V
Unity Gain Bandwidth	$V_{OUT} = 90mV$	25	-	4	-	-	4	-	MHz
OUTPUT CHARACTERISTICS									
Output Voltage Swing		Full	± 35	-	-	± 35	-	-	V
Output Current	$R_L = 1k\Omega$	25	± 12	± 15	-	± 10	± 12	-	mA
Output Resistance	Open Loop	25	-	500	-	-	500	-	Ω
Full Power Bandwidth (Note 3)	$V_{OUT} = \pm 35V$	25	-	23	-	-	23	-	kHz
TRANSIENT RESPONSE $A_V = +1$, $C_L = 50pF$, $R_L = 5k\Omega$									
Rise Time	$V_{OUT} = \pm 200mV$	25	-	60	135	-	60	135	ns
Overshoot	$V_{OUT} = \pm 200mV$	25	-	15	30		15	40	%
Slew Rate		25	± 3	± 5	-	± 2.5	± 5	-	V/ μs
POWER SUPPLY CHARACTERISTICS									
Supply Current		25	-	3.2	3.8	-	3.2	4.5	mA
Supply Voltage Range		Full	± 10	-	± 40	± 10	-	± 40	V
Power Supply Rejection Ratio	$V_S = \pm 10V$ to $\pm 40V$	Full	80	90	-	74	90	-	dB

NOTES:

- This parameter is based upon design calculations.
- Full Power Bandwidth guaranteed based upon slew rate measurement: $FPBW = S.R./2\pi V_{PEAK}$; $V_{PEAK} = 35V$.

Schematic Diagram

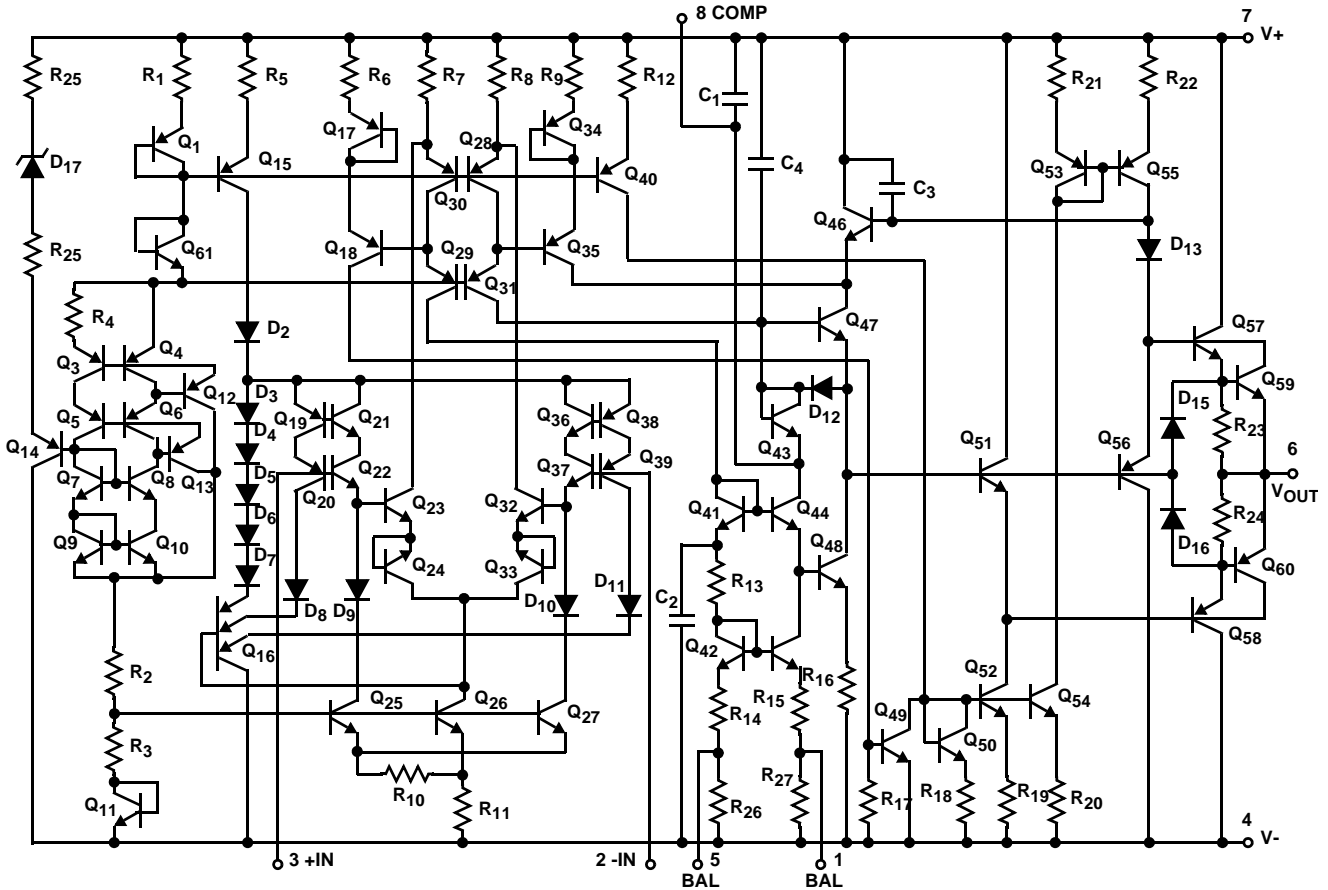

Test Circuits and Waveform

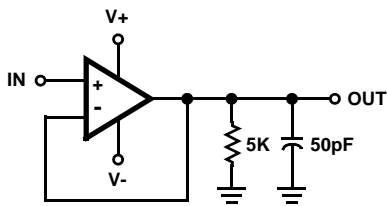
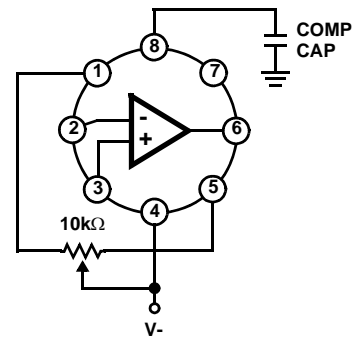

FIGURE 1. SLEW RATE AND TRANSIENT RESPONSE TEST CIRCUIT



NOTE: Tested offset adjustment range is $|V_{OS} + 1mV|$ minimum referred to output. Typical range is $\pm 20mV$ with $R_T = 10k\Omega$.

FIGURE 2. SUGGESTED V_{OS} ADJUSTMENT AND COMPENSATION HOOK UP

Test Circuits and Waveform (Continued)

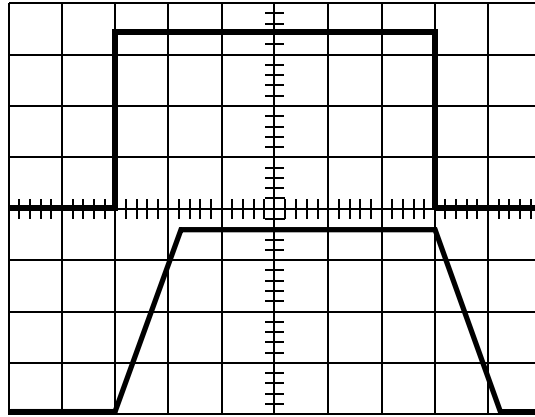

Vertical = 10V/Div., Horizontal = 5μs/Div.

NOTE: $R_L = 5k\Omega$, $C_L = 50pF$, $T_A = 25^\circ C$, $V_S = \pm 40V$

FIGURE 3. VOLTAGE FOLLOWER PULSE RESPONSE

Typical Performance Curves $V_S = \pm 40V$, $T_A = 25^\circ C$, Unless Otherwise Specified

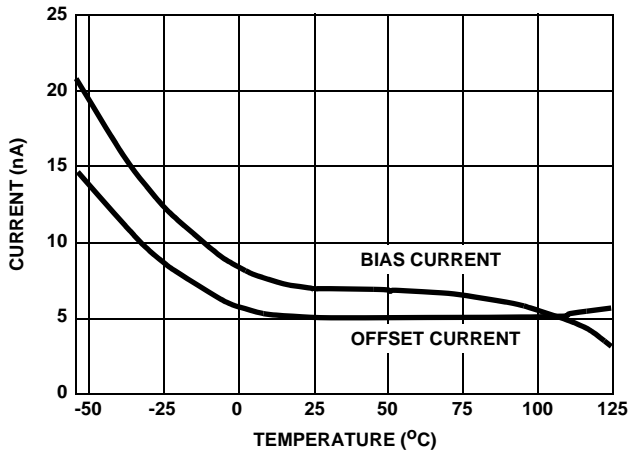

FIGURE 4. INPUT BIAS AND OFFSET CURRENT vs TEMPERATURE

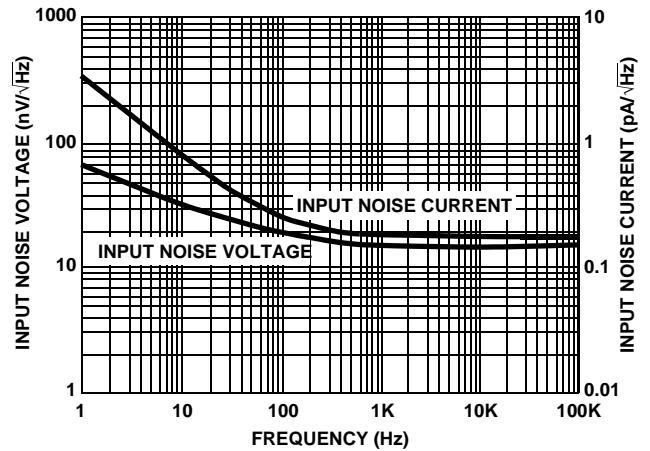

FIGURE 5. INPUT NOISE CHARACTERISTICS

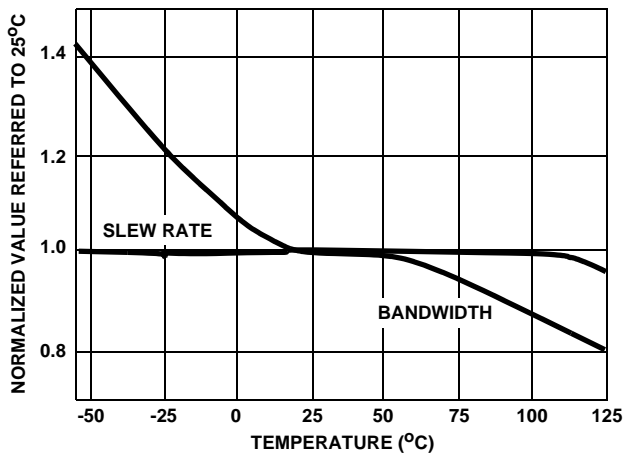

FIGURE 6. NORMALIZED AC PARAMETERS vs TEMPERATURE

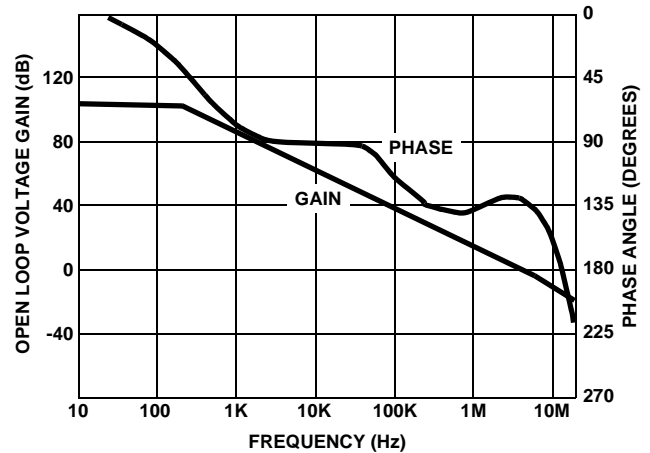

FIGURE 7. OPEN LOOP FREQUENCY RESPONSE

Typical Performance Curves $V_S = \pm 40V$, $T_A = 25^\circ C$, Unless Otherwise Specified (Continued)

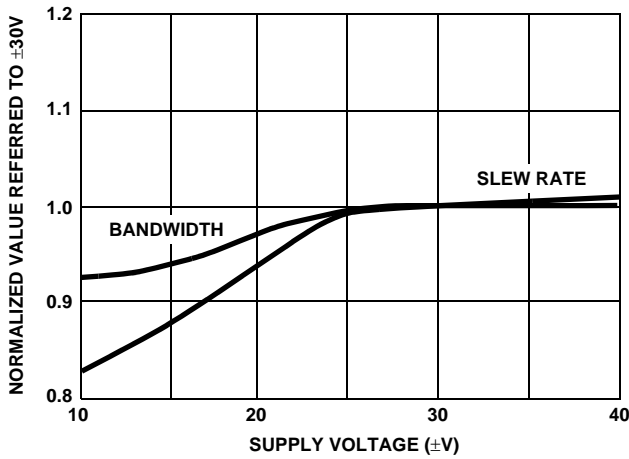

FIGURE 8. NORMALIZED AC PARAMETERS vs SUPPLY VOLTAGE AT 25°C

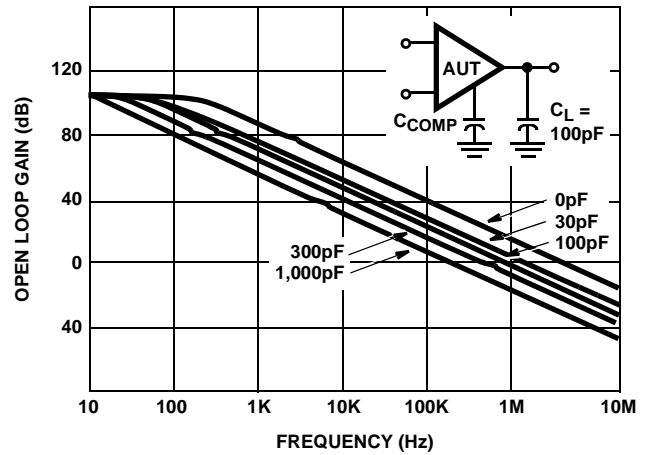

FIGURE 9. OPEN LOOP FREQUENCY RESPONSE FOR VARIOUS VALUES OF CAPACITORS FROM COMPENSATION PIN TO GROUND

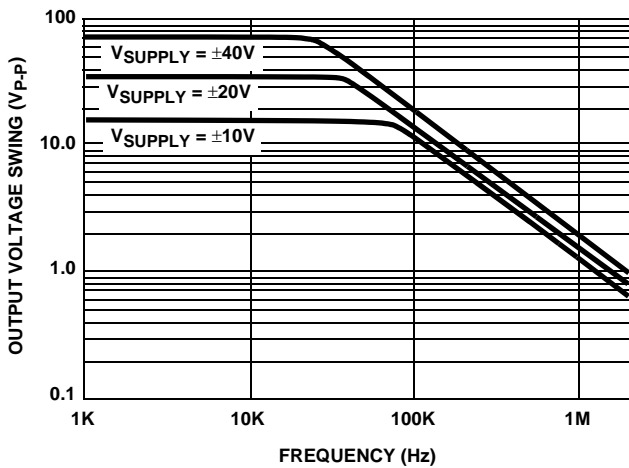

FIGURE 10. OUTPUT VOLTAGE SWING vs FREQUENCY

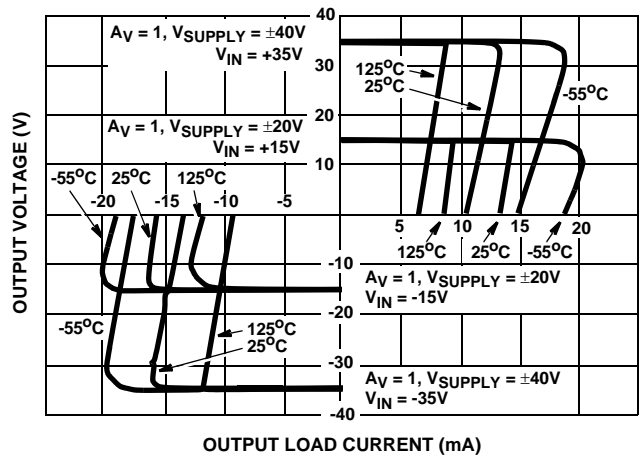

FIGURE 11. OUTPUT CURRENT CHARACTERISTIC

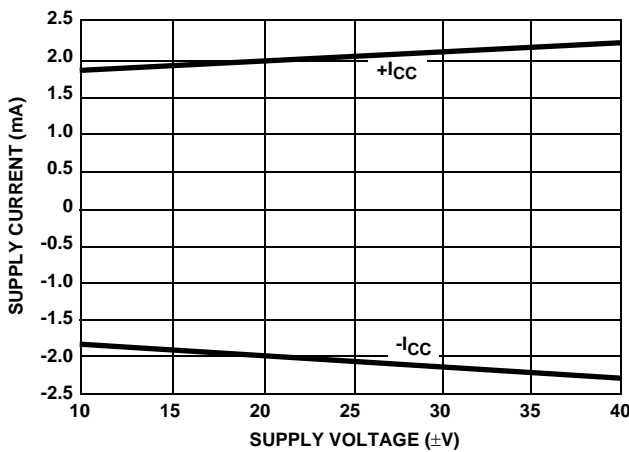

FIGURE 12. SUPPLY CURRENT vs SUPPLY VOLTAGE

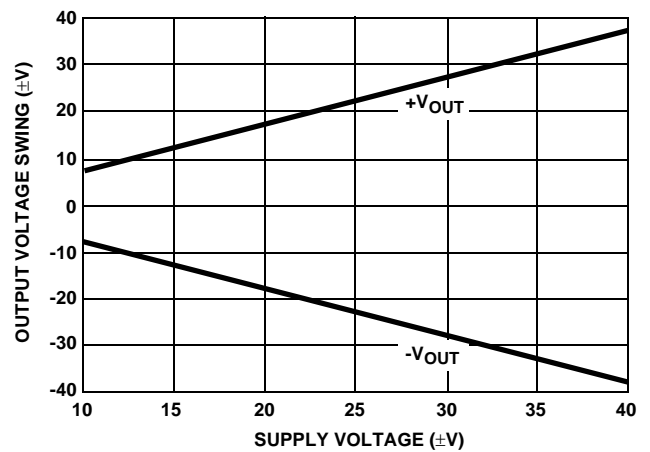

FIGURE 13. OUTPUT VOLTAGE SWING vs SUPPLY VOLTAGE

Die Characteristics

SUBSTRATE POTENTIAL (Powered Up):

Unbiased

TRANSISTOR COUNT:

76

PROCESS:

HV200 Bipolar Dielectric Isolation

Metallization Mask Layout

HA-2640, HA-2645

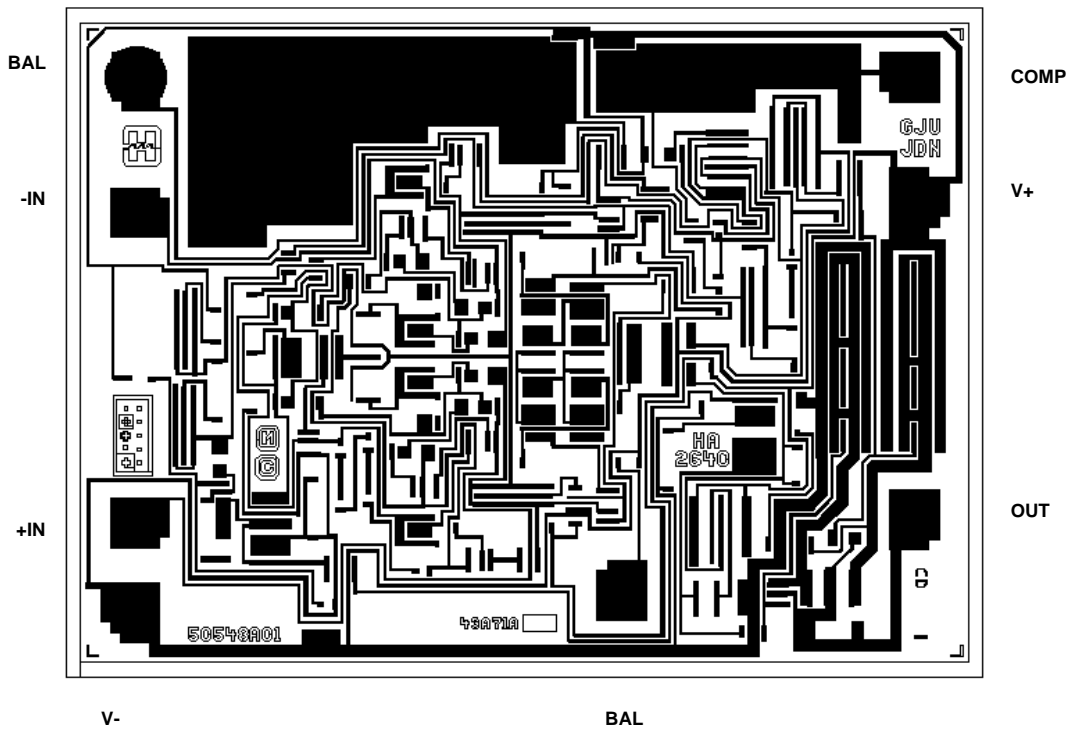

Metal Can Packages (Can)

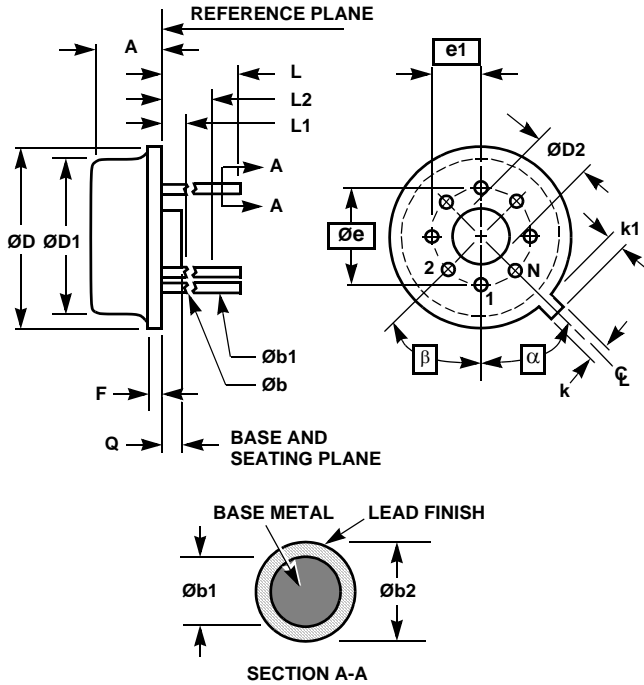

NOTES:

1. (All leads) $\varnothing b$ applies between L1 and L2. $\varnothing b1$ applies between L2 and 0.500 from the reference plane. Diameter is uncontrolled in L1 and beyond 0.500 from the reference plane.
2. Measured from maximum diameter of the product.
3. α is the basic spacing from the centerline of the tab to terminal 1 and β is the basic spacing of each lead or lead position (N - 1 places) from α , looking at the bottom of the package.
4. N is the maximum number of terminal positions.
5. Dimensioning and tolerancing per ANSI Y14.5M - 1982.
6. Controlling dimension: INCH.

**T8.C MIL-STD-1835 MACY1-X8 (A1)
8 LEAD METAL CAN PACKAGE**

SYMBOL	INCHES		MILLIMETERS		NOTES
	MIN	MAX	MIN	MAX	
A	0.165	0.185	4.19	4.70	-
$\varnothing b$	0.016	0.019	0.41	0.48	1
$\varnothing b1$	0.016	0.021	0.41	0.53	1
$\varnothing b2$	0.016	0.024	0.41	0.61	-
$\varnothing D$	0.335	0.375	8.51	9.40	-
$\varnothing D1$	0.305	0.335	7.75	8.51	-
$\varnothing D2$	0.110	0.160	2.79	4.06	-
e	0.200 BSC		5.08 BSC		-
e1	0.100 BSC		2.54 BSC		-
F	-	0.040	-	1.02	-
k	0.027	0.034	0.69	0.86	-
k1	0.027	0.045	0.69	1.14	2
L	0.500	0.750	12.70	19.05	1
L1	-	0.050	-	1.27	1
L2	0.250	-	6.35	-	1
Q	0.010	0.045	0.25	1.14	-
α	45° BSC		45° BSC		3
β	45° BSC		45° BSC		3
N	8		8		4

Rev. 0 5/18/94

Ceramic Dual-In-Line Frit Seal Packages (CERDIP)

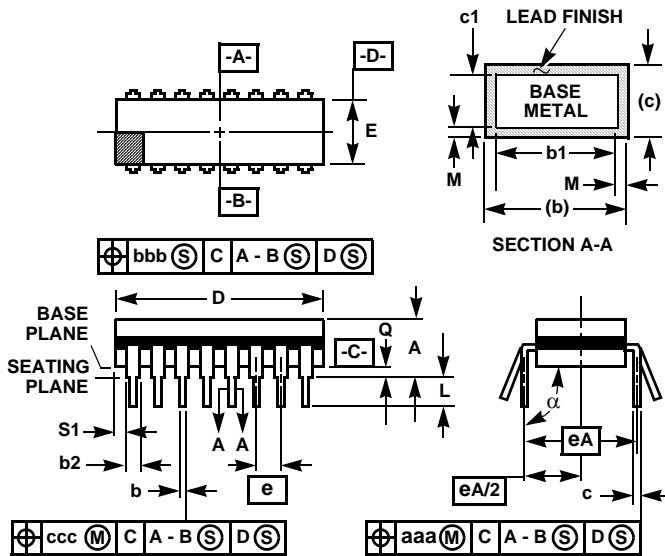

F8.3A MIL-STD-1835 GDIP1-T8 (D-4, CONFIGURATION A)
8 LEAD CERAMIC DUAL-IN-LINE FRIT SEAL PACKAGE

SYMBOL	INCHES		MILLIMETERS		NOTES
	MIN	MAX	MIN	MAX	
A	-	0.200	-	5.08	-
b	0.014	0.026	0.36	0.66	2
b1	0.014	0.023	0.36	0.58	3
b2	0.045	0.065	1.14	1.65	-
b3	0.023	0.045	0.58	1.14	4
c	0.008	0.018	0.20	0.46	2
c1	0.008	0.015	0.20	0.38	3
D	-	0.405	-	10.29	5
E	0.220	0.310	5.59	7.87	5
e	0.100 BSC		2.54 BSC		-
eA	0.300 BSC		7.62 BSC		-
eA/2	0.150 BSC		3.81 BSC		-
L	0.125	0.200	3.18	5.08	-
Q	0.015	0.060	0.38	1.52	6
S1	0.005	-	0.13	-	7
α	90°	105°	90°	105°	-
aaa	-	0.015	-	0.38	-
bbb	-	0.030	-	0.76	-
ccc	-	0.010	-	0.25	-
M	-	0.0015	-	0.038	2, 3
N	8		8		8

NOTES:

1. Index area: A notch or a pin one identification mark shall be located adjacent to pin one and shall be located within the shaded area shown. The manufacturer's identification shall not be used as a pin one identification mark.
2. The maximum limits of lead dimensions b and c or M shall be measured at the centroid of the finished lead surfaces, when solder dip or tin plate lead finish is applied.
3. Dimensions b1 and c1 apply to lead base metal only. Dimension M applies to lead plating and finish thickness.
4. Corner leads (1, N, N/2, and N/2+1) may be configured with a partial lead paddle. For this configuration dimension b3 replaces dimension b2.
5. This dimension allows for off-center lid, meniscus, and glass overrun.
6. Dimension Q shall be measured from the seating plane to the base plane.
7. Measure dimension S1 at all four corners.
8. N is the maximum number of terminal positions.
9. Dimensioning and tolerancing per ANSI Y14.5M - 1982.
10. Controlling dimension: INCH

Rev. 0 4/94

All Intersil U.S. products are manufactured, assembled and tested utilizing ISO9000 quality systems.
Intersil Corporation's quality certifications can be viewed at www.intersil.com/design/quality

Intersil products are sold by description only. Intersil Corporation reserves the right to make changes in circuit design, software and/or specifications at any time without notice. Accordingly, the reader is cautioned to verify that data sheets are current before placing orders. Information furnished by Intersil is believed to be accurate and reliable. However, no responsibility is assumed by Intersil or its subsidiaries for its use; nor for any infringements of patents or other rights of third parties which may result from its use. No license is granted by implication or otherwise under any patent or patent rights of Intersil or its subsidiaries.

For information regarding Intersil Corporation and its products, see www.intersil.com

X-ON Electronics

Largest Supplier of Electrical and Electronic Components

Click to view similar products for [Operational Amplifiers - Op Amps](#) category:

Click to view products by [Renesas](#) manufacturer:

Other Similar products are found below :

[OPA2991IDSGR](#) [OPA607IDCKT](#) [007614D](#) [633773R](#) [635798C](#) [635801A](#) [702115D](#) [709228FB](#) [741528D](#) [NCV33072ADR2G](#)
[SC2902DTBR2G](#) [SC2903DR2G](#) [SC2903VDR2G](#) [LM258AYDT](#) [LM358SNG](#) [430227FB](#) [430228DB](#) [460932C](#) [AZV831KTR-G1](#) [409256CB](#)
[430232AB](#) [LM2904DR2GH](#) [LM358YDT](#) [LT1678IS8](#) [042225DB](#) [058184EB](#) [070530X](#) [SC224DR2G](#) [SC239DR2G](#) [SC2902DG](#)
[SCYA5230DR2G](#) [714228XB](#) [714846BB](#) [873836HB](#) [MIC918YC5-TR](#) [TS912BIYDT](#) [NCS2004MUTAG](#) [NCV33202DMR2G](#)
[M38510/13101BPA](#) [NTE925](#) [SC2904DR2G](#) [SC358DR2G](#) [LM358EDR2G](#) [AZV358MTR-G1](#) [AP4310AUMTR-AG1](#) [HA1630D02MMEL-E](#)
[NJM358CG-TE2](#) [HA1630S01LPEL-E](#) [LM324AWPT](#) [HA1630Q06TELL-E](#)