

## FEATURES

- **Guaranteed 20 ppm/°C Drift**
- **Guaranteed 40 ppm/°C Drift (SO-8 Package)**
- **20 $\mu$ A to 20mA Operation (1.2V)**
- **Dynamic Impedance: 1 $\Omega$**
- **7V, 100 $\mu$ A Reference**

## APPLICATIONS

- Portable Meters
- Precision Regulators
- Calibrators

## DESCRIPTION

The LT<sup>®</sup>1034 is a micropower, precision 1.2V/2.5V reference combined with a 7V auxiliary reference. The 1.2V/2.5V reference is a trimmed, thin-film, band-gap, voltage reference with 1% initial tolerance and guaranteed 20ppm/°C temperature drift. Operating on only 20 $\mu$ A, the LT1034 offers guaranteed drift, low temperature cycling hysteresis and good long-term stability. The low dynamic impedance makes the LT1034 easy to use from unregulated supplies. The 7V reference is a subsurface zener device for less demanding applications.

The LT1034 reference can be used as a high performance upgrade of the LM385 or LT1004, where guaranteed temperature drift is desired.

 LTC and LT are registered trademarks of Linear Technology Corporation.

## TYPICAL APPLICATION

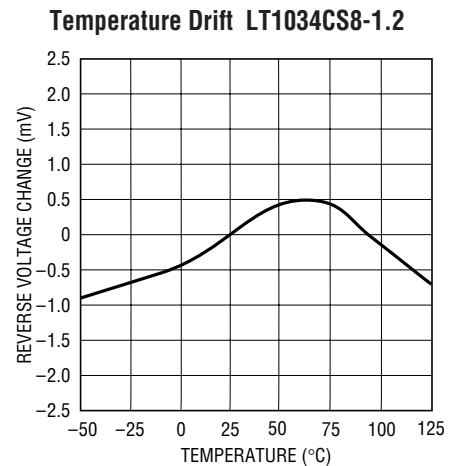
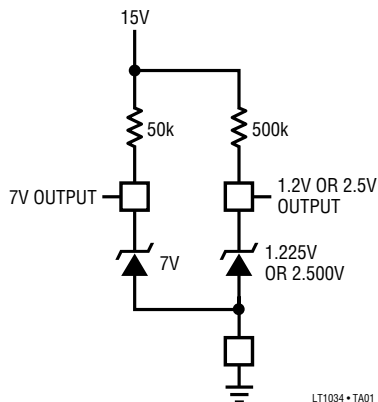

# LT1034-1.2/LT1034-2.5

## ABSOLUTE MAXIMUM RATINGS (Note 1)

Operating Current ..... 20mA  
 Forward Current (Note 2) ..... 20mA  
 Storage Temperature Range ..... -65°C to 150°C  
 Lead Temperature (Soldering, 10 sec)..... 300°C

Operating Temperature  
 Commercial ..... 0° to 70°C  
 Industrial ..... -40°C to 85°C  
 Military (**OBsolete**) ..... -55°C to 125°C

## PACKAGE/ORDER INFORMATION

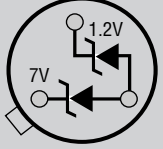
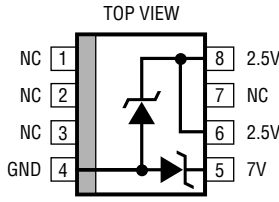
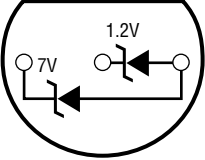
<p>BOTTOM VIEW</p>  <p>H PACKAGE 3-LEAD TO-46 METAL CAN <math>T_{JMAX} = 150^{\circ}\text{C}</math>, <math>\theta_{JA} = 440^{\circ}\text{C/W}</math>, <math>\theta_{JC} = 80^{\circ}\text{C/W}</math></p> <p><b>OBsolete PACKAGE</b> Consider the Z Package for Alternate Source</p>	<p>ORDER PART NUMBER</p> <p>LT1034BCH-1.2                  LT1034BCH-2.5                  LT1034BMH-1.2                  LT1034BMH-2.5                  LT1034CH-1.2                  LT1034CH-2.5                  LT1034MH-1.2                  LT1034MH-2.5</p>	<p>TOP VIEW</p>  <p>S8 PACKAGE 8-LEAD PLASTIC SO</p> <p><math>T_{JMAX} = 175^{\circ}\text{C}</math>, <math>\theta_{JA} = 150^{\circ}\text{C/W}</math></p>	<p>ORDER PART NUMBER</p> <p>LT1034CS8-1.2                  LT1034CS8-2.5                  LT1034IS8-1.2                  LT1034IS8-2.5</p>
<p>BOTTOM VIEW</p>  <p>Z PACKAGE 3-LEAD TO-92 PLASTIC <math>T_{JMAX} = 100^{\circ}\text{C}</math>, <math>\theta_{JA} = 160^{\circ}\text{C/W}</math></p>	<p>ORDER PART NUMBER</p> <p>LT1034BCZ-1.2                  LT1034BCZ-2.5                  LT1034BIZ-1.2                  LT1034BIZ-2.5                  LT1034CZ-1.2                  LT1034CZ-2.5                  LT1034IZ-1.2                  LT1034IZ-2.5</p>		<p>PART MARKING</p> <p>3401                  3402                  1034I12                  34I02</p>

Consult LTC Marketing for parts specified with wider operating temperature ranges.

**ELECTRICAL CHARACTERISTICS** The ● denotes the specifications which apply over the full operating temperature range, otherwise specifications are at  $T_A = 25^\circ\text{C}$ .

PARAMETER	CONDITIONS		LT1034-1.2			LT1034-2.5			UNITS
			MIN	TYP	MAX	MIN	TYP	MAX	
Reverse Breakdown Voltage	$I_R = 100\mu\text{A}$	●	1.210	1.225	1.240	2.46	2.5	2.54	V
			1.205	1.225	1.245	2.43	2.5	2.57	V
Reverse Breakdown Change with Current	(Note 4) $2\text{mA} \leq I_R \leq 20\text{mA}$	●		0.5	2.0		1.0	3.0	mV
				1.0	4.0		1.5	6.0	mV
				4.0	8.0		6.0	16.0	mV
				6.0	15.0		10.0	20.0	mV
Minimum Operating Current		●	10	20		15	30	$\mu\text{A}$	
Temperature Coefficient	$I_R = 100\mu\text{A}$ LT1034B LT1034	●		10	20		10	20	ppm/ $^\circ\text{C}$
				20	40		20	40	ppm/ $^\circ\text{C}$
Reverse Dynamic Impedance (Note 3)	$I_R = 100\mu\text{A}$	●		0.25	1.0		0.5	1.5	$\Omega$
				0.50	2.0		1.0	2.5	$\Omega$
Low Frequency Noise	$I_R = 100\mu\text{A}$ , $0.1\text{Hz} \leq F \leq 10\text{Hz}$	●		4			6	$\mu\text{V}_{\text{P-P}}$	
Long-Term Stability	$I_R = 100\mu\text{A}$			20			20	ppm/ $\sqrt{\text{kh}}$	

The ● denotes the specifications which apply over the full operating temperature range, otherwise specifications are at  $T_A = 25^\circ\text{C}$ .  
**7V Reference.**

PARAMETER	CONDITIONS		MIN	TYP	MAX	UNITS
Reverse Breakdown Voltage	$I_R = 100\mu\text{A}$	●	6.80	7.0	7.3	V
			6.75	7.0	7.4	V
Reverse Breakdown Change with Current	$100\mu\text{A} \leq I_R \leq 1\text{mA}$	●		90	140	mV
	$100\mu\text{A} \leq I_R \leq 1\text{mA}$			100	190	mV
	$1\text{mA} \leq I_R \leq 20\text{mA}$			160	250	mV
	$1\text{mA} \leq I_R \leq 20\text{mA}$			200	350	mV
Temperature Coefficient	$I_R = 100\mu\text{A}$	●		40		ppm/ $^\circ\text{C}$
Long-Term Stability	$I_R = 100\mu\text{A}$			20		ppm/ $\sqrt{\text{kh}}$

**Note 1:** Absolute Maximum Ratings are those values beyond which the life of a device may be impaired.

**Note 2:** Forward biasing either diode will affect the operation of the other diode.

**Note 3:** This parameter guaranteed by “reverse breakdown change with current” test.

**Note 4:** For the LT1034-1.2:  $20\mu\text{A} \leq I_R \leq 2\text{mA}$ . For the LT1034-2.5:  $30\mu\text{A} \leq I_R \leq 2\text{mA}$ .

# TYPICAL PERFORMANCE CHARACTERISTICS

**Reverse Voltage Change 1.2V**

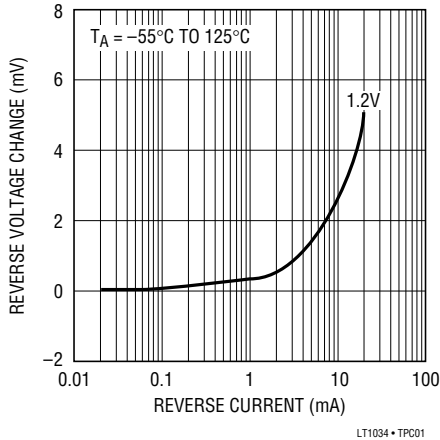

LT1034 • TPC01

**Reverse Voltage Change 7V**

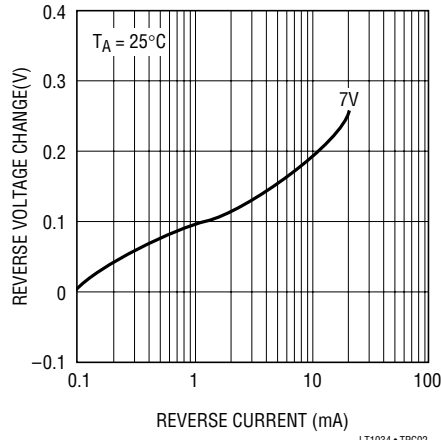

LT1034 • TPC02

**0.1Hz to 10Hz Noise 1.2V**

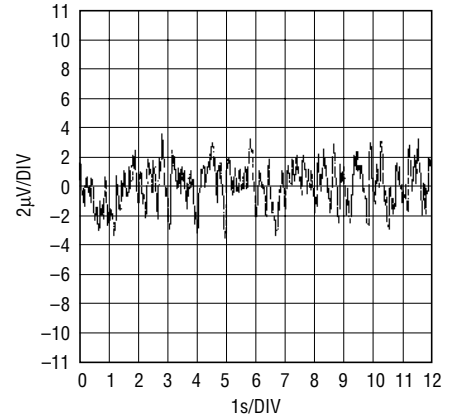

LT1034 • TPC03

**Reverse Dynamic Impedance 1.2V**

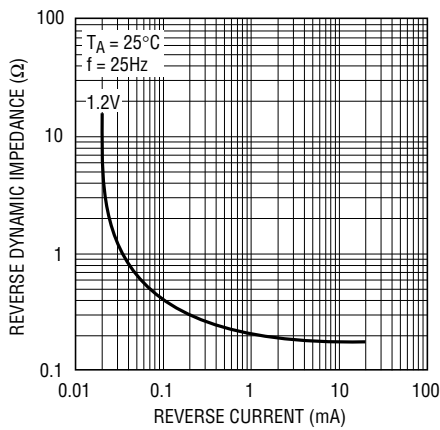

LT1034 • TPC04

**Reverse Dynamic Impedance 2.5V**

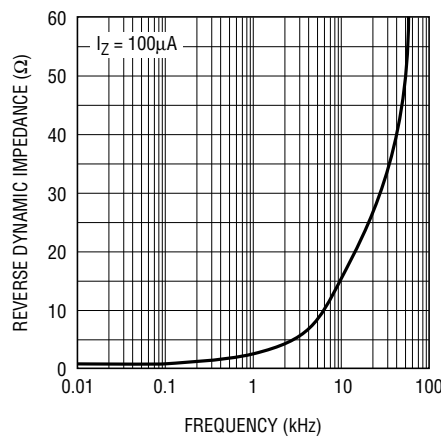

LT1034 • TPC05

**Reverse Dynamic Impedance 7V**

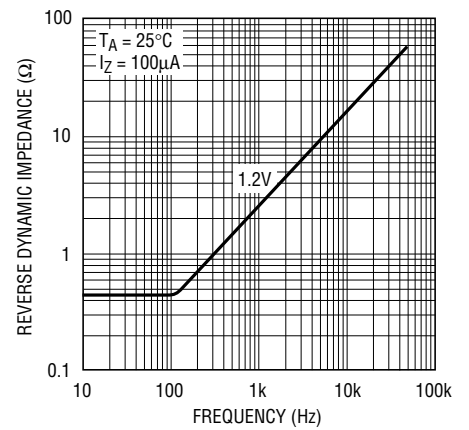

LT1034 • TPC06

# TYPICAL PERFORMANCE CHARACTERISTICS

Reverse Characteristics 1.2V

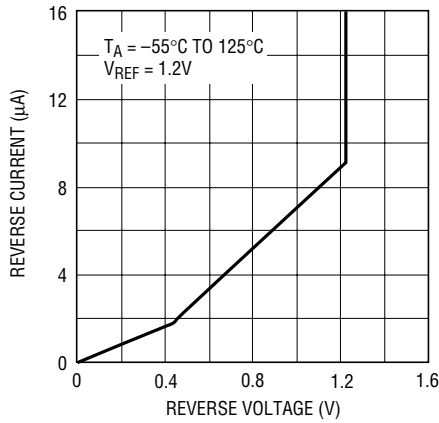

LT1034 • TPC07

Reverse Characteristics 2.5V

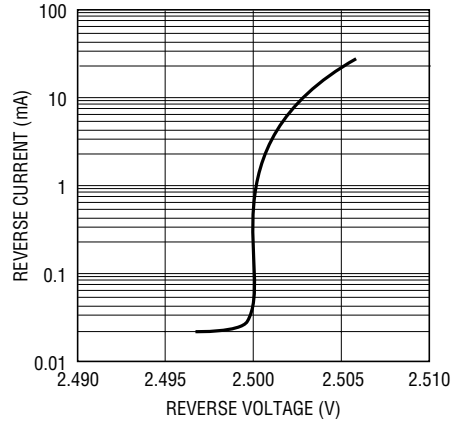

LT1034 • TPC02

Reverse Characteristics 7V

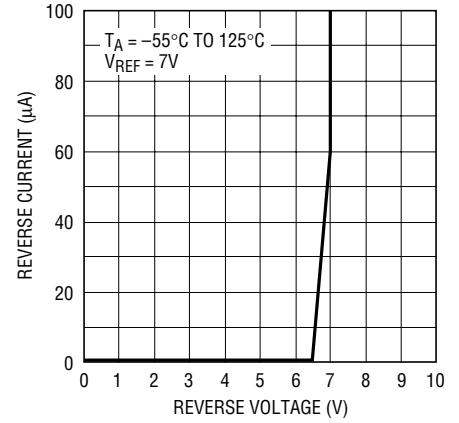

LT1034 • TPC09

Forward Characteristics

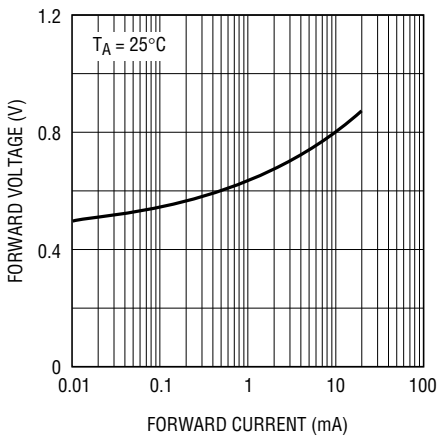

LT1034 • TPC10

Response Time

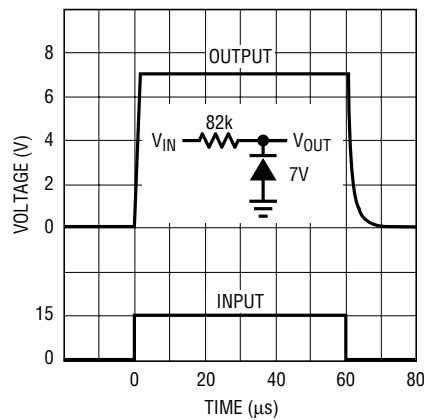

LT1180A • TPC11

Response Time

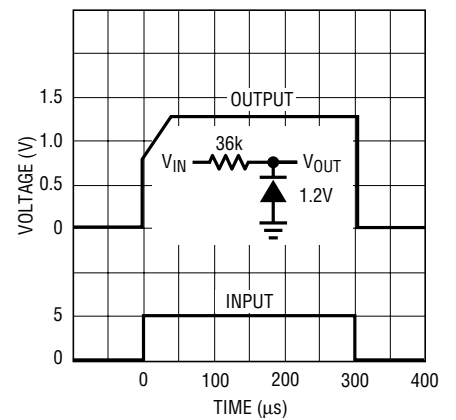

LT1180A • TPC12

**PACKAGE DESCRIPTION**

**H Package**  
**8-Lead TO-5 Metal Can (.200 Inch PCD)**  
 (Reference LTC DWG # 05-08-1320)

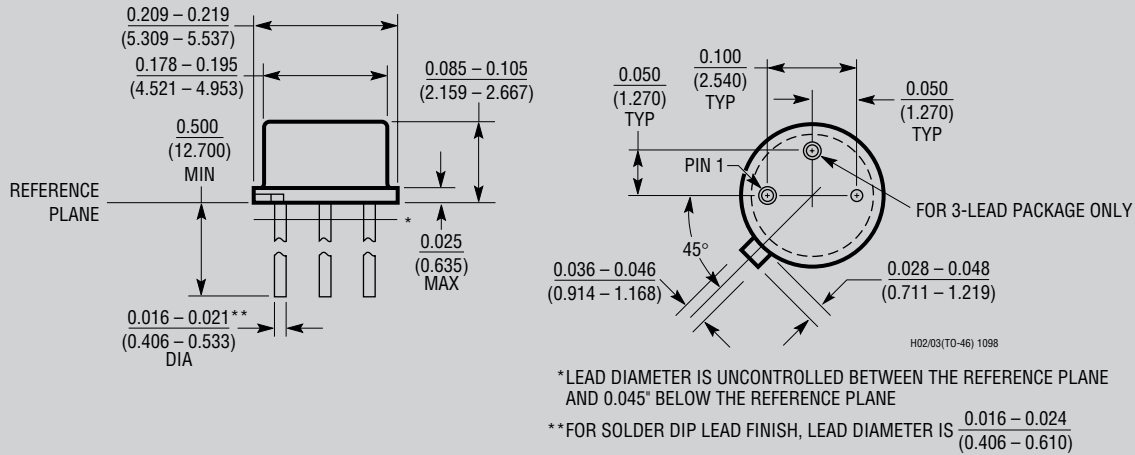

**OBsolete PACKAGE**

**S8 Package**  
**8-Lead Plastic Small Outline (Narrow .150 Inch)**  
 (Reference LTC DWG # 05-08-1610)

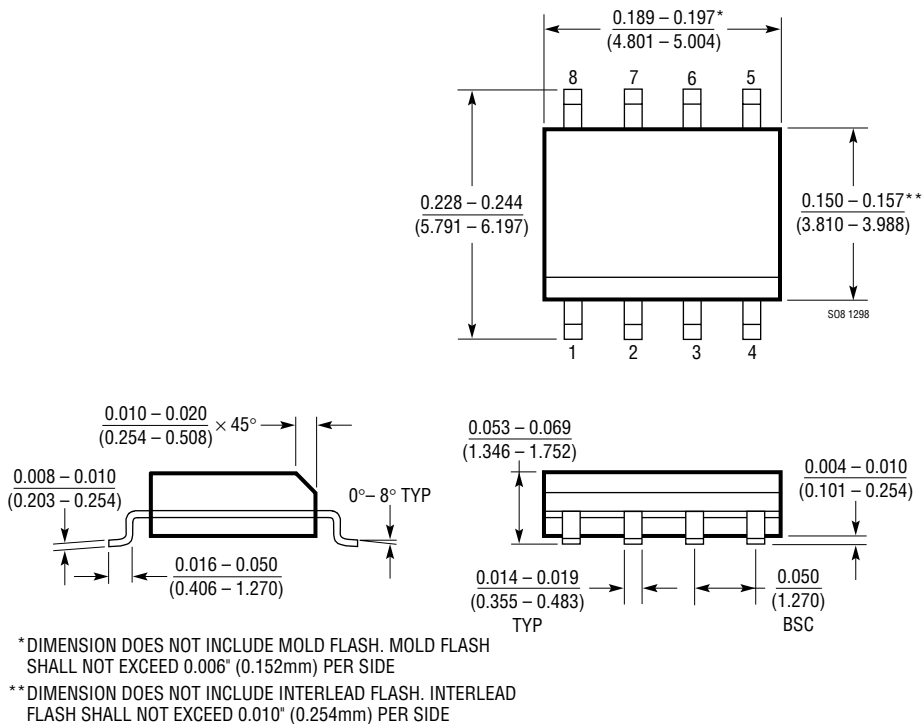

**PACKAGE DESCRIPTION**

**Z Package**  
**3-Lead Plastic TO-92 (Similar to TO-226)**  
 (Reference LTC DWG # 05-08-1410)

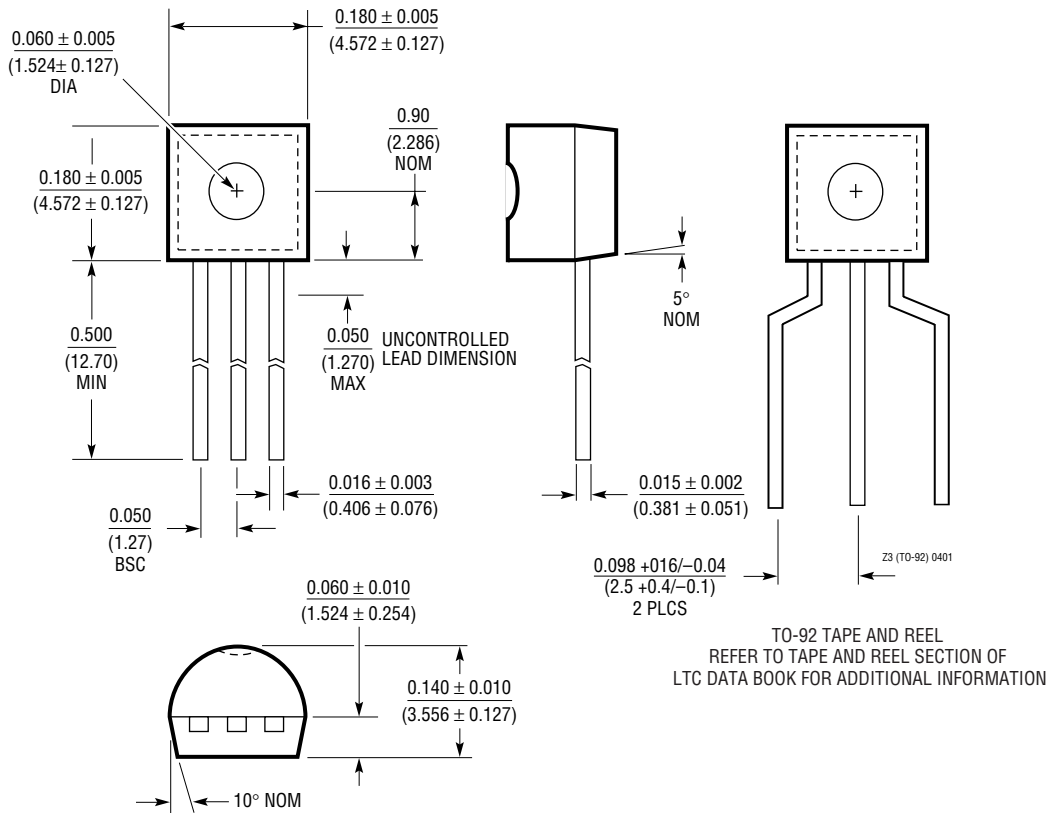

# LT1034-1.2/LT1034-2.5

---

## RELATED PARTS

PART NUMBER	DESCRIPTION	COMMENTS
LT1004	Low Cost Precision Band-Gap	Micropower, SO-8, Industrial Temperature Options
LT1019	Precision Series or Shunt Band-Gap	Low Dropout, Multiple Output Options
LT1236	Precision Series or Shunt Buried Zener	Low Noise, Low Power, Multiple Output Options



## X-ON Electronics

Largest Supplier of Electrical and Electronic Components

*Click to view similar products for [Voltage References](#) category:*

*Click to view products by [Analog Devices](#) manufacturer:*

Other Similar products are found below :

[622664A](#) [636116E](#) [748389C](#) [AS431ARTR-E1](#) [NCP431BCSNT1G](#) [NCP432BCSNT1G](#) [NCV431BSNT1G](#) [AP4313UKTR-G1](#)  
[TL1431AIYDT](#) [AZ431BR-ATRE1](#) [622668D](#) [NCP432BVSNT1G](#) [712504A](#) [TLV431CSN1T1G](#) [5962-8686103XC](#) [NCV431BVDMR2G](#)  
[LT1460JCS3-2.5#TRMPBF](#) [LT1460JCS3-3.3#TRMPBF](#) [LT6654AMPS6-3.3#TRMPBF](#) [LT6654AMPS6-3#TRMPBF](#) [LT1460KCS3-](#)  
[3#TRMPBF](#) [LT1460KCS3-2.5#TRMPBF](#) [LT1004CZ-2.5#TRPBF](#) [LT1460HCS3-3.3#TRMPBF](#) [AZ432BNTR-G1](#) [LT1460HCS3-5#TRMPBF](#)  
[LT1460HCS3-2.5#TRMPBF](#) [AP4306BUKTR-G1](#) [LT6654AMPS6-2.5#TRMPBF](#) [SC431BVSNT1G](#) [MAX6023EBT30+T](#) [LT1460KCS3-](#)  
[3.3#TRMPBF](#) [NCV431ASNT1G](#) [LTC6655BHLS8-5#PBF](#) [LT6657AHMS8-1.25#PBF](#) [LT1460HCS3-3#TRMPBF](#) [LT1027DILS8-5#PBF](#)  
[LM4040CEM3-5.0/V+T](#) [LT1009CZ#TRPBF](#) [LT6654BHS6-2.048#TRMPBF](#) [LT1460KCS3-3#TRM](#) [LT1460KCS3-3.3#TRM](#) [LT6660KCDC-](#)  
[10#TRMPBF](#) [LTC6652AHLS8-5#PBF](#) [LTC6652BHLS8-5#PBF](#) [LM336Z-2.5#PBF](#) [LTC6655CHLS8-4.096#PBF](#) [SC431ILPRAG](#)  
[TLVH431MIL3T](#) [MAX6023EBT21+T](#)