

R76 Series Double Metallized Polypropylene Film, Radial, DC and Pulse Applications (Automotive Grade)

Overview

The R76 Series is constructed of polypropylene film and double metallized polyester film as electrodes with radial leads of tinned wire. The radial leads are electrically welded to the metal layer on the ends of the capacitor winding. The capacitor is encapsulated in a self-extinguishing solvent resistant plastic case with thermosetting resin material meeting the UL 94V-0 requirements. Two different winding constructions are used depending on voltage parameters. Please see the Performance Characteristics for more information.

Automotive grade devices are available (up to lead spacing 22.5 mm) and meet the demanding Automotive Electronics Council's AEC-Q200 qualification requirements.

Applications

Typical applications include deflection circuits in televisions (S-correction and flyback tuning) and monitors, switching spikes suppression in switched mode power supplies (SMPS), lamp capacitors for electronic ballasts and compact lamps, and snubber and silicon-controlled rectifier (SCR) commutation circuits as well as applications with high voltage and high current. Not suitable for across-the-line application (see Suppressor Capacitors).

Benefits

- Voltage range: 250 – 2,000 VDC
- Capacitance range: 100 pF – 15 μ F
- Lead Spacing: 7.5 mm – 37.5 mm
- Capacitance tolerance: \pm 5%, \pm 10%, \pm 20%
- Climatic category: 55/105/56 IEC 60068-1
- Operating temperature range of -55° C to $+105^{\circ}$ C
- RoHS compliance and lead-free terminations
- Tape and reel packaging in accordance with IEC 60286-2
- Self-healing
- Automotive (AEC-Q200) grades available up to lead spacing 22.5mm

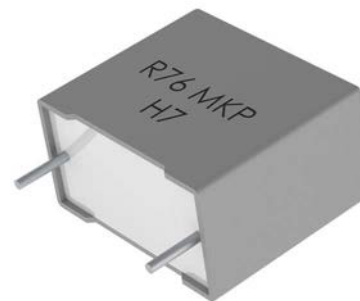

Part Number System

R76	I	D	1680	SE	30	K
Series	Rated Voltage (VDC)	Lead Spacing (mm)	Capacitance Code (pF)	Packaging	Internal Use	Capacitance Tolerance
Double Metallized Polypropylene	I = 250 M = 400 P = 630 Q = 1,000 T = 1,600 U = 2,000	D = 7.5 F = 10 I = 15 N = 22.5 R = 27.5 W = 37.5	The last three digits represent significant figures. The first digit specifies the total number of zeros to be added.	See Ordering Options Table	00 10 30 40 50 60 70 80	H = 2.5% J = \pm 5% K = \pm 10%

Ordering Options Table

Lead Spacing Nominal (mm)	Type of Leads and Packaging	Lead Length (mm)	Lead and Packaging Code
7.5	Standard Lead and Packaging Options		
	Bulk (Bag) – Short Leads	4 +2/-0	SE
	Ammo Pack	$H_0 = 18.5 \pm 0.5$	DQ
	Other Lead and Packaging Options		
	Tape & Reel (Standard Reel)	$H_0 = 18.5 \pm 0.5$	CK
	Bulk (Bag)–Short Leads	2.7 +0.5/-0	JA
	Bulk (Bag)–Short Leads	3.5 +0.5/-0	JB
	Bulk (Bag)–Short Leads	10 +/-1	JC
	Bulk (Bag)–Short Leads	4.0 +0.5/-0	JE
	Bulk (Bag)–Short Leads	3.2 +0.3/-0.2	JH
	Bulk (Bag)–Long Leads	18 +1/-1	JM
Bulk (Bag)–Long Leads	17 +1/-2	Z3	
10 15 22.5	Standard Lead and Packaging Options		
	Bulk (Bag) – Short Leads	4 +2/-0	SE
	Ammo Pack	$H_0 = 18.5 \pm 0.5$	DQ
	Other Lead and Packaging Options		
	Tape & Reel (Standard Reel)	$H_0 = 18.5 \pm 0.5$	GY
	Tape & Reel (Large Reel)	$H_0 = 18.5 \pm 0.5$	CK
	Bulk (Bag)–Short Leads	2.7 +0.5/-0	JA
	Bulk (Bag)–Short Leads	3.5 +0.5/-0	JB
	Bulk (Bag)–Short Leads	10 +/-1	JC
	Bulk (Bag)–Short Leads	4.0 +0.5/-0	JE
	Bulk (Bag)–Short Leads	3.2 +0.3/-0.2	JH
	Bulk (Bag)–Long Leads	18 +1/-1	JM
	Bulk (Bag)–Long Leads	30 +5/-0	40
	Bulk (Bag)–Long Leads	25 +2/-1	50
27.5	Standard Lead and Packaging Options		
	Bulk (Bag) – Short Leads	4 +2/-0	SE
	Other Lead and Packaging Options		
	Tape & Reel (Large Reel)	$H_0 = 18.5 \pm 0.5$	CK
	Bulk (Bag)–Short Leads	3.5 +0.5/-0	JB
	Bulk (Bag)–Short Leads	4.0 +0.5/-0	JE
	Bulk (Bag)–Short Leads	3.2 +0.3/-0.2	JH
	Bulk (Bag)–Long Leads	30 +5/-0	40
Bulk (Bag) – Long Leads	25 +2/-1	50	

Ordering Options Table cont'd

Lead Spacing Nominal (mm)	Type of Leads and Packaging	Lead Length (mm)	Lead and Packaging Code
37.5	Standard Lead and Packaging Options		
	Bulk (Bag)–Short Leads	4 +2/-0	SE
	Other Lead and Packaging Options		
	Bulk (Bag)–Short Leads	3.5 +0.5/-0	JB
	Bulk (Bag)–Short Leads	4.0 +0.5/-0	JE
	Bulk (Bag)–Short Leads	3.2 +0.3/-0.2	JH
	Bulk (Bag)–Long Leads	30 +5/-0	40
	Bulk (Bag) – Long Leads	25 +2/-1	50

Dimensions – Millimeters

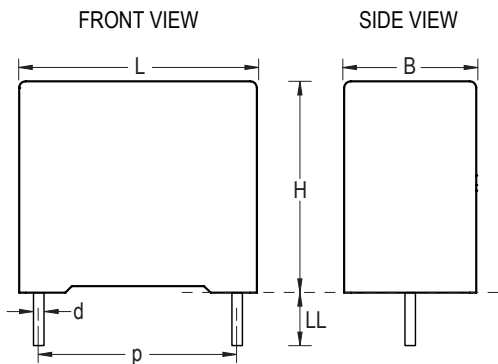

p		B		H		L		d	
Nominal	Tolerance	Nominal	Tolerance	Nominal	Tolerance	Nominal	Tolerance	Nominal	Tolerance
7.5	+/- 0.4	3.0	+0.1	8.0	+0.1	10.0	+0.2	0.5	+/- 0.05
7.5	+/- 0.4	4.0	+0.1	9.0	+0.1	10.0	+0.2	0.6	+/- 0.05
7.5	+/- 0.4	5.0	+0.1	10.5	+0.1	10.0	+0.2	0.6	+/- 0.05
7.5	+/-0.4	6.0	+0.1	12.0	+0.1	10.0	+0.2	0.6	+/- 0.05
10.0	+/- 0.4	4.0	+0.2	9.0	+0.1	13.0	+0.2	0.6	+/- 0.05
10.0	+/- 0.4	5.0	+0.2	11.0	+0.1	13.0	+0.2	0.6	+/- 0.05
10.0	+/-0.4	6.0	+0.2	12.0	+0.1	13.0	+0.2	0.6	+/- 0.05
15.0	+/- 0.4	4.0	+0.2	10.0	+0.1	18.0	+0.3	0.8	+/- 0.05
15.0	+/- 0.4	5.0	+0.2	11.0	+0.1	18.0	+0.3	0.8	+/- 0.05
15.0	+/- 0.4	6.0	+0.2	12.0	+0.1	18.0	+0.3	0.8	+/- 0.05
15.0	+/- 0.4	7.5	+0.2	13.5	+0.1	18.0	+0.5	0.8	+/- 0.05
15.0	+/- 0.4	8.5	+0.2	14.5	+0.1	18.0	+0.5	0.8	+/- 0.05
15.0	+/- 0.4	9.0	+0.2	12.5	+0.1	18.0	+0.5	0.8	+/- 0.05
15.0	+/- 0.4	10.0	+0.2	16.0	+0.1	18.0	+0.5	0.8	+/- 0.05

Note: See Ordering Options Table for lead length (LL/Ho) options.

Dimensions – Millimeters cont'd

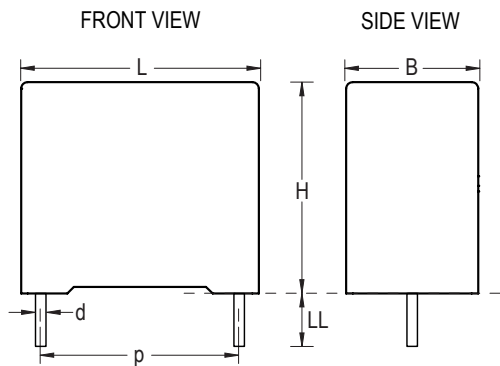

p		B		H		L		d	
Nominal	Tolerance	Nominal	Tolerance	Nominal	Tolerance	Nominal	Tolerance	Nominal	Tolerance
15.0	+/- 0.4	11.0	+0.2	19.0	+0.1	18.0	+0.5	0.8	+/- 0.05
15.0	+/- 0.4	13.0	+0.2	12.0	+0.1	18.0	+0.5	0.8	+/- 0.05
22.5	+/- 0.4	6.0	+0.2	15.0	+0.1	26.5	+0.3	0.8	+/- 0.05
22.5	+/- 0.4	7.0	+0.2	16.0	+0.1	26.5	+0.3	0.8	+/- 0.05
22.5	+/- 0.4	8.5	+0.2	17.0	+0.1	26.5	+0.3	0.8	+/- 0.05
22.5	+/- 0.4	10.0	+0.2	18.5	+0.1	26.5	+0.3	0.8	+/- 0.05
22.5	+/- 0.4	11.0	+0.2	20.0	+0.1	26.5	+0.3	0.8	+/- 0.05
22.5	+/- 0.4	13.0	+0.2	22.0	+0.1	26.5	+0.3	0.8	+/- 0.05
27.5	+/- 0.4	9.0	+0.2	17.0	+0.1	32.0	+0.3	0.8	+/- 0.05
27.5	+/- 0.4	11.0	+0.2	20.0	+0.1	32.0	+0.3	0.8	+/- 0.05
27.5	+/- 0.4	13.0	+0.2	22.0	+0.1	32.0	+0.3	0.8	+/- 0.05
27.5	+/- 0.4	13.0	+0.2	25.0	+0.1	32.0	+0.3	0.8	+/- 0.05
27.5	+/- 0.4	14.0	+0.2	28.0	+0.1	32.0	+0.3	0.8	+/- 0.05
27.5	+/- 0.4	18.0	+0.2	33.0	+0.1	32.0	+0.3	0.8	+/- 0.05
27.5	+/- 0.4	22.0	+0.2	37.0	+0.1	32.0	+0.3	0.8	+/- 0.05
37.5	+/- 0.4	11.0	+0.3	22.0	+0.1	41.5	+0.3	1.0	+/- 0.05
37.5	+/- 0.4	13.0	+0.3	24.0	+0.1	41.5	+0.3	1.0	+/- 0.05
37.5	+/- 0.4	16.0	+0.3	28.5	+0.1	41.5	+0.3	1.0	+/- 0.05
37.5	+/- 0.4	19.0	+0.3	32.0	+0.1	41.5	+0.3	1.0	+/- 0.05
37.5	+/- 0.4	20.0	+0.3	40.0	+0.1	41.5	+0.3	1.0	+/- 0.05
37.5	+/- 0.4	24.0	+0.3	44.0	+0.1	41.5	+0.3	1.0	+/- 0.05
37.5	+/- 0.4	30.0	+0.3	45.0	+0.1	41.5	+0.3	1.0	+/- 0.05

Note: See Ordering Options Table for lead length (LL/Ho) options.

Performance Characteristic

Dielectric	Polypropylene film							
Plates	Double sided metallized polyester film							
Winding	Non-inductive type							
Leads	Tinned wire							
Protection	Plastic case, thermosetting resin filled. Box material is solvent resistant and flame retardant according to UL94.							
Related Documents	IEC 60384-16							
Sections	1				2			
Voltage Range (VDC)	250	400	630	630	1000	1000	1600	2000
Voltage Range (VAC)	180	250	250	400	400	600	650	700
Capacitance Range (µF)	0.0068 – 12	0.0027 – 8.2	0.00068 – 0.012	0.00039 – 4.7	0.00022 – 0.0033	0.00047 – 2.2	0.0033 – 1.2	0.0001 – 0.68
Capacitance Values	E12 series (IEC 60063) measured @ 1 kHz and +20 ±1°C							
Capacitance Tolerance	±2.5%, ±5%, ±10%							
Operating Temperature Range	-55°C to +105°C							
Rated Temperature T _R	+85°C for V _R (DC) +75°C for V _R (AC)							
Voltage Derating	The following decreasing factor has to be applied on the rated voltage: +85°C to +105°C: 1.25% per °C for V _R (DC) +75°C to +105°C: 1.35% per °C for V _R (AC)							
Climatic Category	55/105/56 IEC 60068-1							
Storage Conditions	Storage time: ≤ 24 months from the date marked on the label package							
	Average relative humidity per year ≤ 70%							
	RH ≤ 85% for 30 days randomly distributed throughout the year							
	Dew is absent							
	Temperature: -40 to 80°C (see "Maximum Humidity in Storage Conditions" graph below)							

Maximum Humidity in Storage Conditions

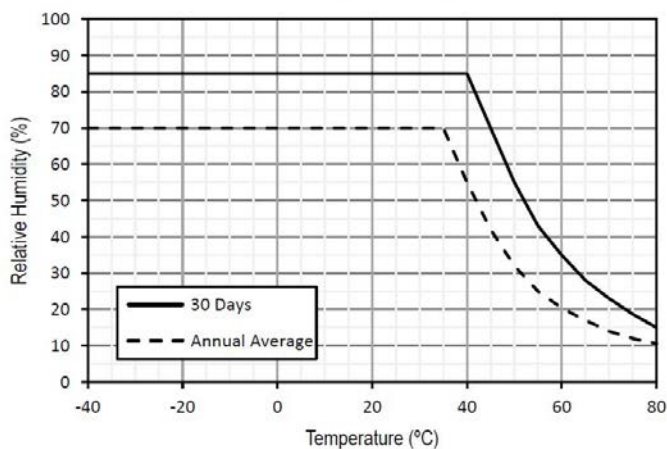

Performance Characteristics cont'd

Test Voltage	1.6 x V _R VDC for 2 seconds (between terminations) @ +25°C ±5°C						
Capacitance Drift	Maximum 0.5% after a 2 year storage period at a temperature of +10°C to +40°C and a relative humidity of 40% to 60%						
Maximum Pulse Steepness	dV/dt according to Table 1. For peak to peak voltages lower than rated voltage (V _{pp} <V _R), the specified dv/dt can be multiplied by the factor V _R /V _{pp}						
Temperature Coefficient	-(200 ±100) ppm/°C at 1 kHz						
Self-Inductance L (Lead Length ~ 2 mm)	Lead Spacing (mm)	7.5	10	15	22.5	27.5	37.5
	L (nH) ≈	8	9	10	18	18	20
Dissipation Factor tanδ	Measured at 25°C ± 5°C						
	Frequency	C ≤ 0.1 μF	0.1 μF < C ≤ 1.0 μF	1.0 μF < C ≤ 4.7 μF	C > 4.7 μF		
	1 kHz	0.04%	0.05%	0.06%	0.10%		
	10 kHz	0.06%	0.08%	-	-		
100 kHz	0.25%	-	-	-			
Insulation Resistance	Measured at +25°C, 100 VDC 60 seconds						
	Minimum Values Between Terminals						
	C ≤ 0.33 μF			C > 0.33 μF			
	≥ 100,000 MΩ (≥ 500,000 MΩ)*			≥ 30,000 MΩ • μF (≥ 150,000 MΩ • μF)*			

* typical value

Qualification

Automotive Grade products meet or exceed the requirements outlined by the Automotive Electronics Council. Details regarding test methods and conditions are referenced in document AEC-Q200, Stress Test Qualification for Passive Components. For additional information regarding the Automotive Electronics Council and AEC-Q200, please visit their website at www.aecouncil.com.

Maximum Voltage (V_{rms}) vs. Frequency (Sinusoidal Waveform/ $Th \leq 40^\circ C$)

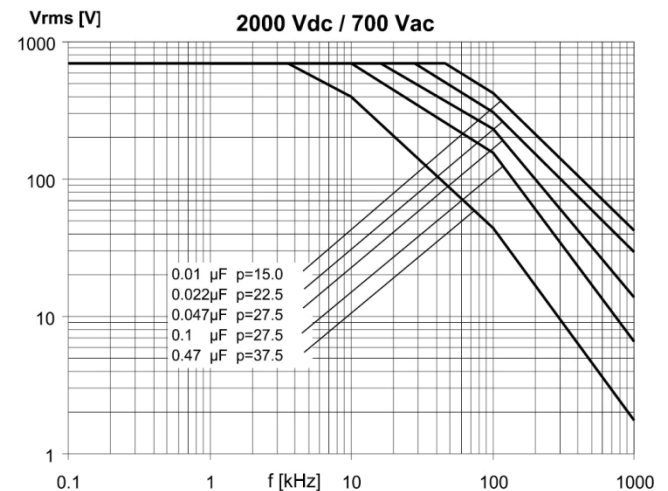
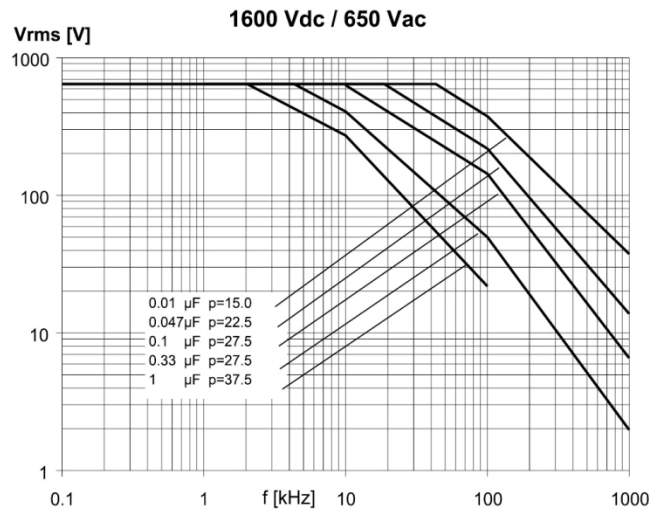
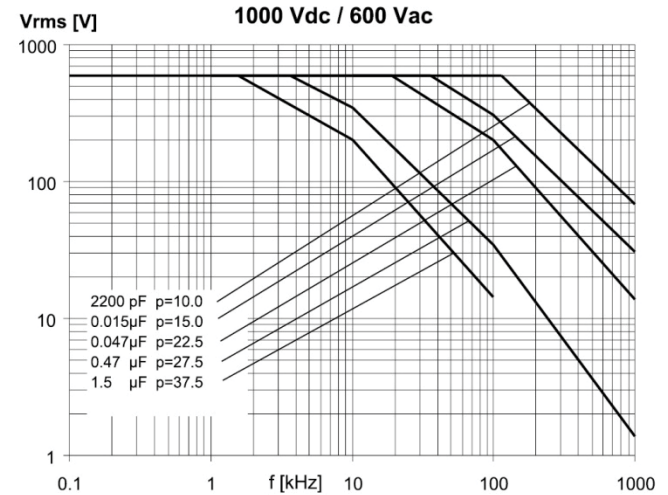
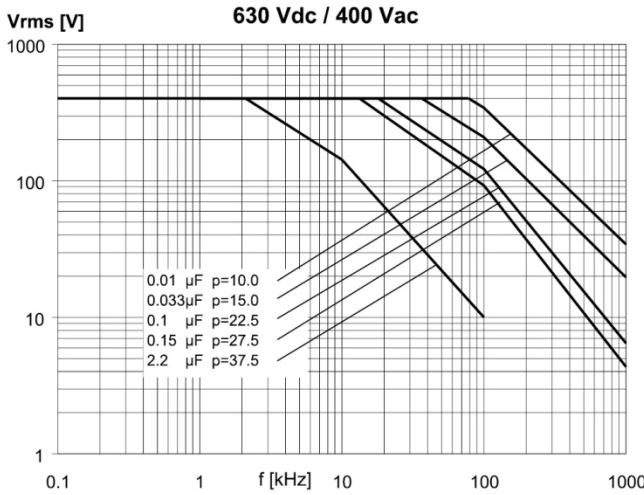
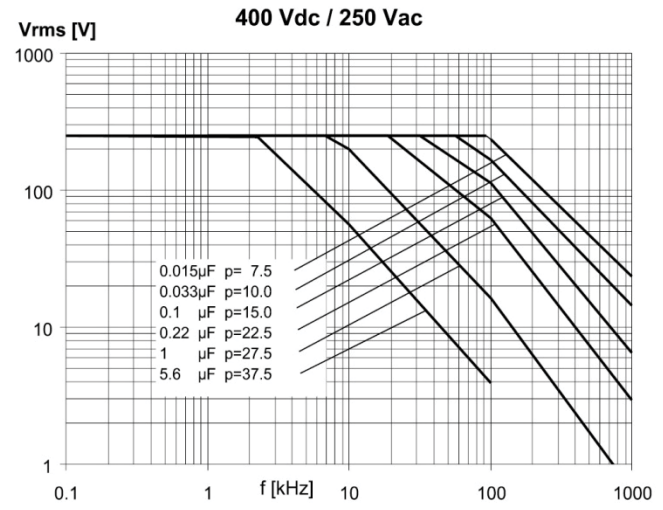
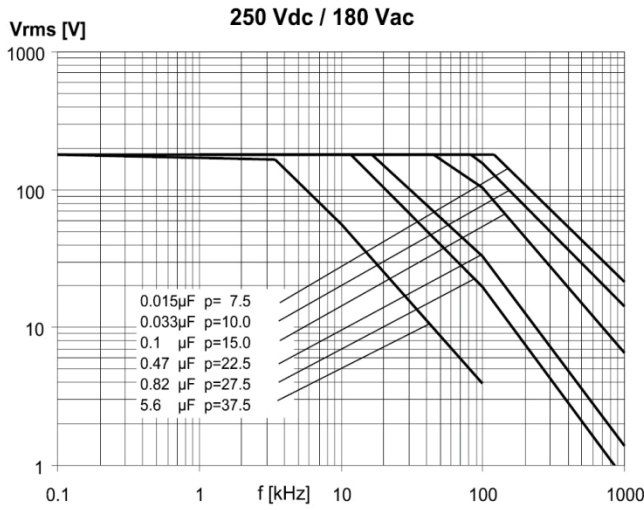

Maximum Current (I_{rms}) vs. Frequency (Sinusoidal Waveform/ $T_h \leq 40^\circ\text{C}$)

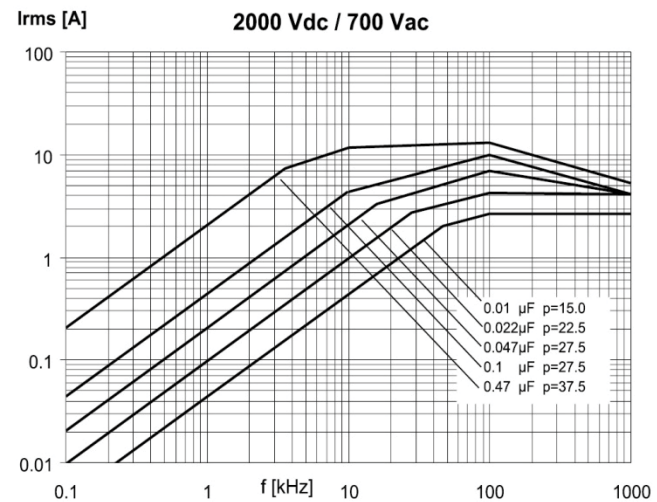
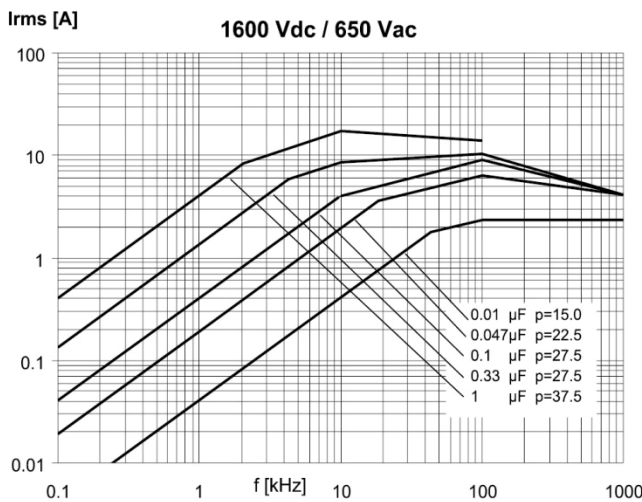
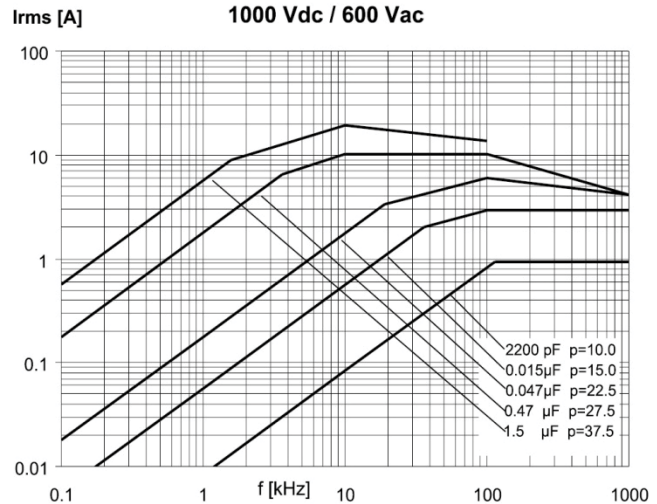
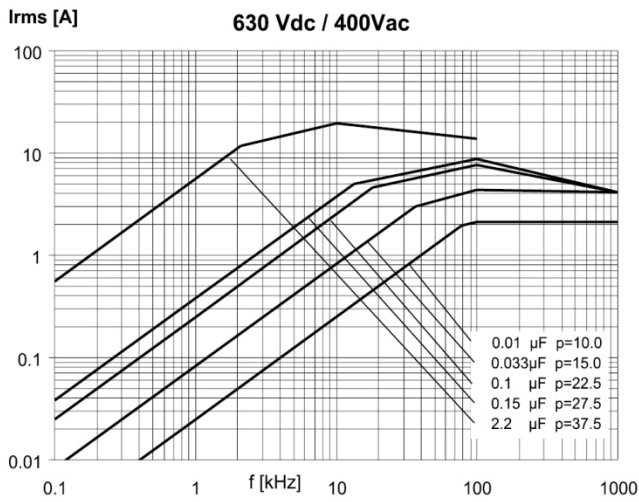
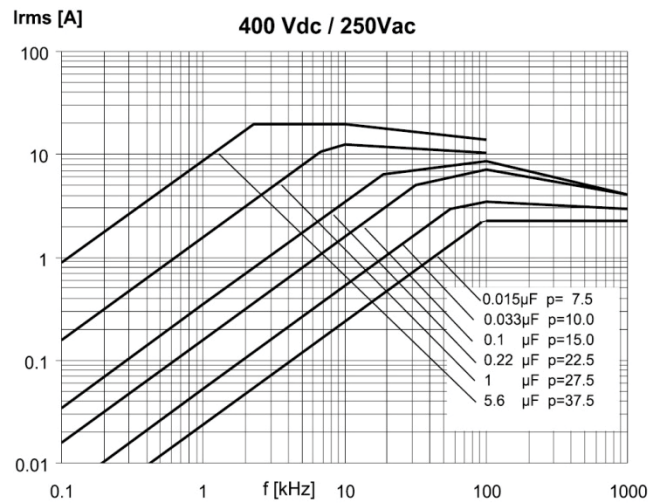
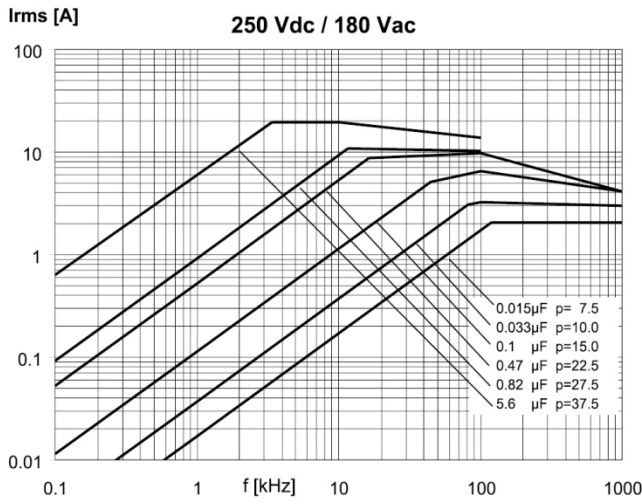

Note: p (pitch) in mm.

Environmental Test Data

Damp Heat, Steady State Test	Test Conditions:		Performances
	Temperature: Relative humidity (RH): Test duration:	+40°C ± 2°C 93% ± 2% 56 days	$ \Delta C/C \leq 2\%$, $\Delta \tan\delta \leq 0.001 @ 1 \text{ kHz}$ IR after test $\geq 50\%$ of initial limit
Endurance Test	Test Conditions		Performances
	Temperature: Voltage applied: Test duration:	+85°C ± 2°C 1.25 x V _R (DC) 2,000 hours	$ \Delta C/C \leq 2\%$, $\Delta \tan\delta \leq 0.001 @ 10 \text{ kHz for } C \leq 1\mu\text{F}$ $\Delta \tan\delta \leq 0.001 @ 1 \text{ kHz for } C > 1\mu\text{F}$ IR after test $\geq 50\%$ of initial limit
Resistance to Soldering Heat Test	Test Conditions		Performances
	Solder bath temperature: Dipping time (with heat screen):	260°C ± 5°C 10 seconds ± 1 second	$ \Delta C/C \leq 1\%$, $\Delta \tan\delta \leq 0.001 @ 10 \text{ kHz for } C \leq 1\mu\text{F}$ $\Delta \tan\delta \leq 0.001 @ 1 \text{ kHz for } C > 1\mu\text{F}$ IR after test \geq initial limit

Environmental Compliance

All KEMET pulse capacitors are RoHS Compliant.

Table 1 – Ratings & Part Number Reference cont'd

VDC	VAC	Capacitance Value (µF)	Dimensions in mm			Lead Spacing (p)	dV/dt (V/µs)	Max K ₀ (V ² /µs)	New KEMET Part Number	Legacy Part Number
			B	H	L					
2,000	700	0.033	8.5	17.0	26.5	22.5	3,500	14,000,000	76UN2330(1)40(2)	R76UN2330(1)40(2)
2,000	700	0.039	10.0	18.5	26.5	22.5	3,500	14,000,000	76UN2390(1)40(2)	R76UN2390(1)40(2)
2,000	700	0.047	10.0	18.5	26.5	22.5	3,500	14,000,000	76UN2470(1)40(2)	R76UN2470(1)40(2)
2,000	700	0.056	11.0	20.0	26.5	22.5	3,500	14,000,000	76UN2560(1)40(2)	R76UN2560(1)40(2)
2,000	700	0.022	9.0	17.0	32.0	27.5	2,300	9,200,000	76UR2220(1)30(2)	R76UR2220(1)30(2)
2,000	700	0.027	9.0	17.0	32.0	27.5	2,300	9,200,000	76UR2270(1)30(2)	R76UR2270(1)30(2)
2,000	700	0.033	9.0	17.0	32.0	27.5	2,300	9,200,000	76UR2330(1)30(2)	R76UR2330(1)30(2)
2,000	700	0.039	11.0	20.0	32.0	27.5	2,300	9,200,000	76UR2390(1)20(2)	R76UR2390(1)20(2)
2,000	700	0.047	11.0	20.0	32.0	27.5	2,300	9,200,000	76UR2470(1)30(2)	R76UR2470(1)30(2)
2,000	700	0.056	13.0	22.0	32.0	27.5	2,300	9,200,000	76UR2560(1)30(2)	R76UR2560(1)30(2)
2,000	700	0.068	13.0	22.0	32.0	27.5	2,300	9,200,000	76UR2680(1)30(2)	R76UR2680(1)30(2)
2,000	700	0.082	13.0	25.0	32.0	27.5	2,300	9,200,000	76UR2820(1)40(2)	R76UR2820(1)40(2)
2,000	700	0.10	14.0	28.0	32.0	27.5	2,300	9,200,000	76UR3100(1)30(2)	R76UR3100(1)30(2)
2,000	700	0.12	18.0	33.0	32.0	27.5	2,300	9,200,000	76UR3120(1)30(2)	R76UR3120(1)30(2)
2,000	700	0.15	18.0	33.0	32.0	27.5	2,300	9,200,000	76UR3150(1)30(2)	R76UR3150(1)30(2)
2,000	700	0.18	22.0	37.0	32.0	27.5	2,300	9,200,000	76UR3180(1)30(2)	R76UR3180(1)30(2)
2,000	700	0.22	22.0	37.0	32.0	27.5	2,300	9,200,000	76UR3220(1)30(2)	R76UR3220(1)30(2)
2,000	700	0.033	11.0	22.0	41.5	37.5	1,500	6,000,000	76UR2330(1)30(2)	R76UR2330(1)30(2)
2,000	700	0.039	11.0	22.0	41.5	37.5	1,500	6,000,000	76UR2390(1)30(2)	R76UR2390(1)30(2)
2,000	700	0.047	11.0	22.0	41.5	37.5	1,500	6,000,000	76UR2470(1)30(2)	R76UR2470(1)30(2)
2,000	700	0.056	11.0	22.0	41.5	37.5	1,500	6,000,000	76UR2560(1)30(2)	R76UR2560(1)30(2)
2,000	700	0.068	11.0	22.0	41.5	37.5	1,500	6,000,000	76UR2680(1)30(2)	R76UR2680(1)30(2)
2,000	700	0.082	11.0	22.0	41.5	37.5	1,500	6,000,000	76UR2820(1)30(2)	R76UR2820(1)30(2)
2,000	700	0.10	13.0	24.0	41.5	37.5	1,500	6,000,000	76UR3100(1)30(2)	R76UR3100(1)30(2)
2,000	700	0.12	13.0	24.0	41.5	37.5	1,500	6,000,000	76UR3120(1)30(2)	R76UR3120(1)30(2)
2,000	700	0.15	16.0	28.5	41.5	37.5	1,500	6,000,000	76UR3150(1)30(2)	R76UR3150(1)30(2)
2,000	700	0.18	16.0	28.5	41.5	37.5	1,500	6,000,000	76UR3180(1)30(2)	R76UR3180(1)30(2)
2,000	700	0.22	19.0	32.0	41.5	37.5	1,500	6,000,000	76UR3220(1)30(2)	R76UR3220(1)30(2)
2,000	700	0.27	20.0	40.0	41.5	37.5	1,500	6,000,000	76UR3270(1)30(2)	R76UR3270(1)30(2)
2,000	700	0.33	20.0	40.0	41.5	37.5	1,500	6,000,000	76UR3330(1)30(2)	R76UR3330(1)30(2)
2,000	700	0.39	24.0	44.0	41.5	37.5	1,500	6,000,000	76UR3390(1)30(2)	R76UR3390(1)30(2)
2,000	700	0.47	24.0	44.0	41.5	37.5	1,500	6,000,000	76UR3470(1)30(2)	R76UR3470(1)30(2)
2,000	700	0.56	30.0	45.0	41.5	37.5	1,500	6,000,000	76UR3560(1)30(2)	R76UR3560(1)30(2)
2,000	700	0.68	30.0	45.0	41.5	37.5	1,500	6,000,000	76UR3680(1)30(2)	R76UR3680(1)30(2)
VDC	VAC	Capacitance Value (µF)	B (mm)	H (mm)	L (mm)	Lead Spacing (p)	dV/dt (V/µs)	Max K ₀ (V ² /µs)	New KEMET Part Number	Legacy Part Number

(1) Insert lead and packaging code. See Ordering Options Table for available options.

(2) H = 2.5%, J = 5%, K = 10%

Soldering Process

The implementation of the RoHS directive has resulted in the selection of SnAgCu (SAC) alloys or SnCu alloys as primary solder. This has increased the liquidus temperature from that of 183°C for SnPb eutectic alloy to 217 – 221°C for the new alloys. As a result, the heat stress to the components, even in wave soldering, has increased considerably due to higher pre-heat and wave temperatures. Polypropylene capacitors are especially sensitive to heat (the melting point of polypropylene is 160 – 170°C). Wave soldering can be destructive, especially for mechanically small polypropylene capacitors (with lead spacing of 5 mm to 15 mm), and great care has to be taken during soldering. The recommended solder profiles from KEMET should be used. Please consult KEMET with any questions. In general, the wave soldering curve from IEC Publication 61760-1 Edition 2 serves as a solid guideline for successful soldering. Please see Figure 1.

Reflow soldering is not recommended for through-hole film capacitors. Exposing capacitors to a soldering profile in excess of the above the recommended limits may result to degradation or permanent damage to the capacitors.

Do not place the polypropylene capacitor through an adhesive curing oven to cure resin for surface mount components. Insert through-hole parts after the curing of surface mount parts. Consult KEMET to discuss the actual temperature profile in the oven, if through-hole components must pass through the adhesive curing process. A maximum two soldering cycles is recommended. Please allow time for the capacitor surface temperature to return to a normal temperature before the second soldering cycle.

Manual Soldering Recommendations

Following is the recommendation for manual soldering with a soldering iron.

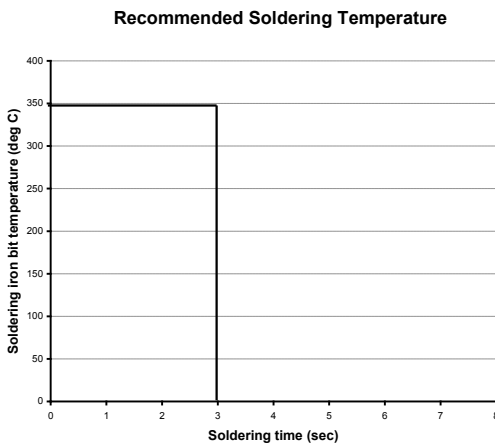

The soldering iron tip temperature should be set at 350°C (+10°C maximum) with the soldering duration not to exceed more than 3 seconds.

Wave Soldering Recommendations

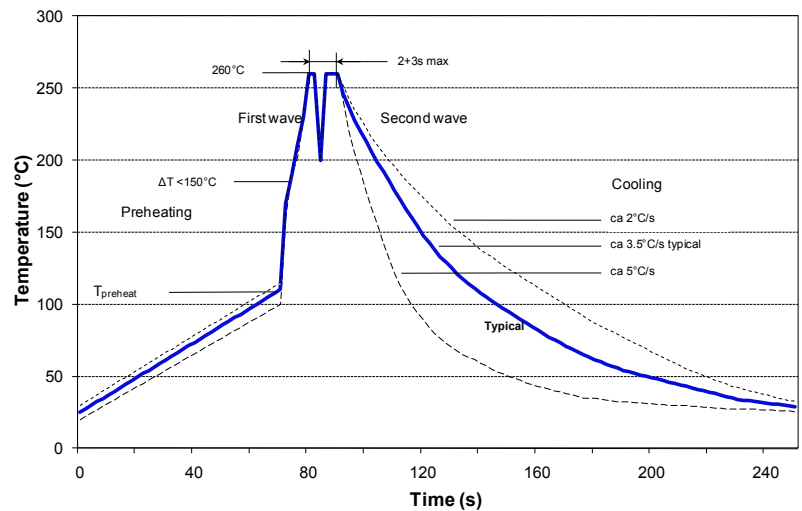

Soldering Process cont'd

Wave Soldering Recommendations cont'd

1. The table indicates the maximum set-up temperature of the soldering process

Figure 1

Dielectric Film Material	Maximum Preheat Temperature			Maximum Peak Soldering Temperature	
	Capacitor Pitch ≤ 10 mm	Capacitor Pitch = 15 mm	Capacitor Pitch > 15 mm	Capacitor Pitch ≤ 15 mm	Capacitor Pitch > 15 mm
Polyester	130°C	130°C	130°C	270°C	270°C
Polypropylene	100°C	110°C	130°C	260°C	270°C
Paper	130°C	130°C	140°C	270°C	270°C
Polyphenylene Sulphide	150°C	150°C	160°C	270°C	270°C

2. The maximum temperature measured inside the capacitor:

Set the temperature so that inside the element the maximum temperature is below the limit:

Dielectric Film Material	Maximum temperature measured inside the element
Polyester	160°C
Polypropylene	110°C
Paper	160°C
Polyphenylene sulphide	160°C

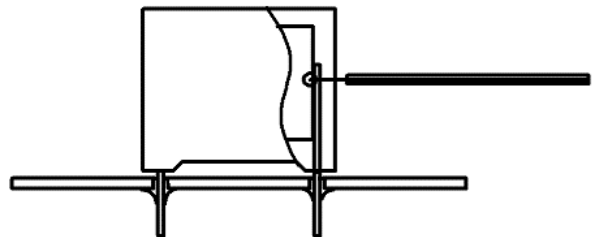

Temperature monitored inside the capacitor.

Selective Soldering Recommendations

Selective dip soldering is a variation of reflow soldering. In this method, the printed circuit board with through-hole components to be soldered is preheated and transported over the solder bath as in normal flow soldering without touching the solder. When the board is over the bath, it is stopped and pre-designed solder pots are lifted from the bath with molten solder only at the places of the selected components, and pressed against the lower surface of the board to solder the components.

The temperature profile for selective soldering is similar to the double wave flow soldering outlined in this document, **however, instead of two baths, there is only one bath with a time from 3 to 10 seconds.** In selective soldering, the risk of overheating is greater than in double wave flow soldering, and great care must be taken so that the parts are not overheated.

Construction

1 Section

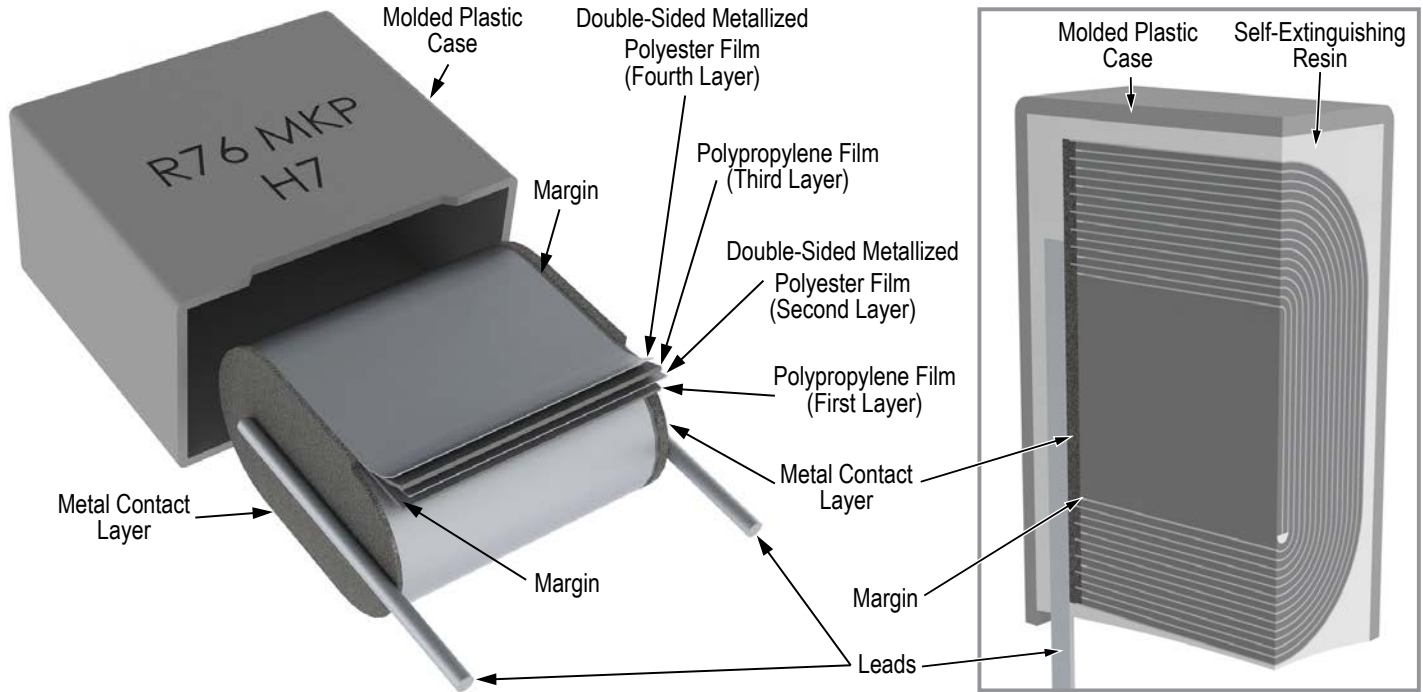

Winding Schemes

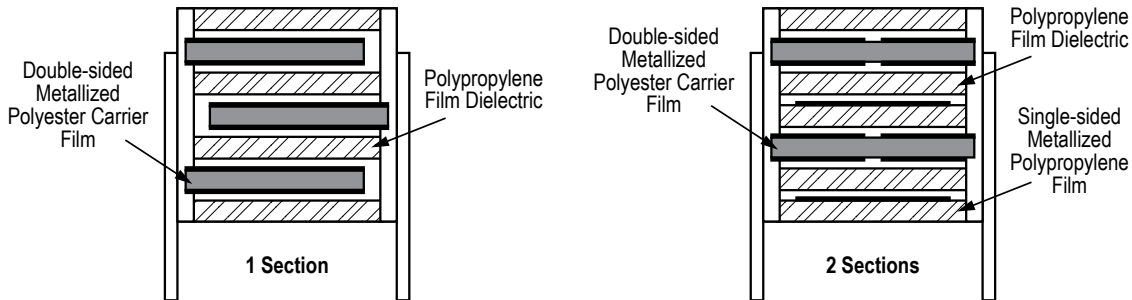

Marking

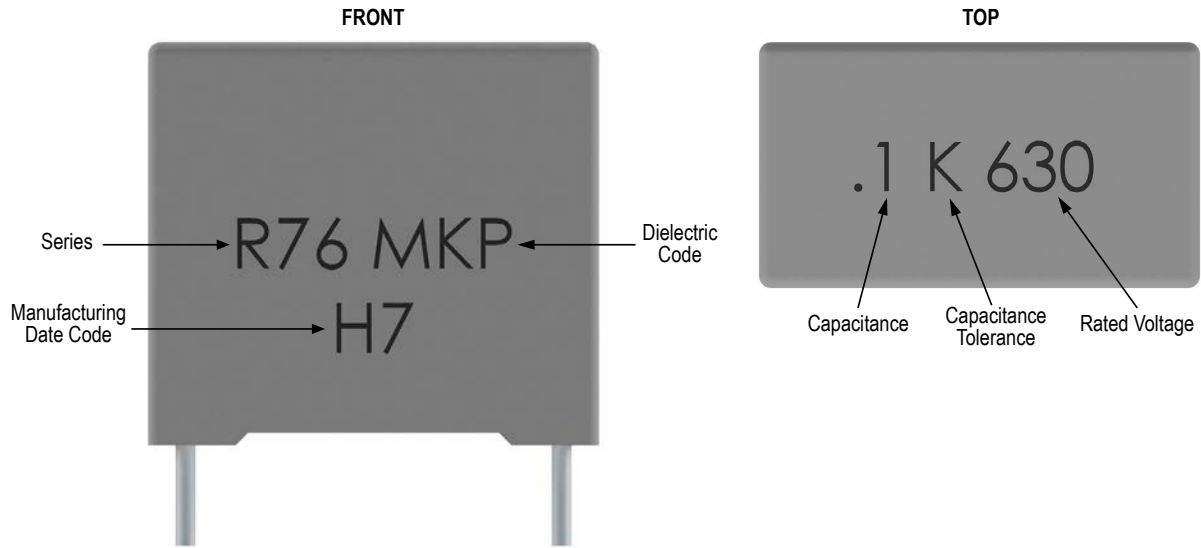

Packaging Quantities

Lead Spacing	Thickness (mm)	Height (mm)	Length (mm)	Bulk Short Leads	Bulk Long Leads	Standard Reel ø 355 mm	Large Reel ø 500 mm	Ammo Taped
7.5	3.0	8.0	10.0	1,500	1,750	2,100		2,800
	4.0	9.0	10.0	2,000	1,500	1,500		2,100
	5.0	10.5	10.0	1,500	1,000	1,200		1,600
	6.0	12.0	10.5	1,000	800	1,000		1,350
10	4.0	9.0	13.0	2,000	1,800	750	1,500	1,000
	5.0	11.0	13.0	1,300	1,500	600	1,250	800
	6.0	12.0	13.0	1,000	1,200	500	1,000	680
15	4.0	10.0	18.0	2,500	1,500	-	1,500	1,000
	5.0	11.0	18.0	2,000	1,000	600	1,250	800
	6.0	12.0	18.0	1,750	900	500	1,000	680
	7.5	13.5	18.0	1,000	700	350	800	500
	8.5	14.5	18.0	1,000	500	300	700	440
	9.0	12.5	18.0	1,000	520	270	650	410
	10.0	16.0	18.0	750	500	300	600	380
	11.0	19.0	18.0	450	350	-	500	340
22.5	13.0	12.0	18.0	750	490	200	480	280
	6.0	15.0	26.5	805	500		700	464
	7.0	16.0	26.5	700	500		550	380
	8.5	17.0	26.5	468	300		450	280
	10.0	18.5	26.5	396	300		350	235
	11.0	20.0	26.5	360	250		350	217
27.5	13.0	22.0	26.5	300	200		300	-
	9.0	17.0	32.0	816	408		450	
	11.0	20.0	32.0	560	336		350	
	13.0	22.0	32.0	480	288		300	
	13.0	25.0	32.0	480	288			
	14.0	28.0	32.0	352	176			
	18.0	33.0	32.0	256	128			
37.5	22.0	37.0	32.0	168	112			
	11.0	22.0	41.5	420	252			
	13.0	24.0	41.5	360	216			
	16.0	28.5	41.5	216	108			
	19.0	32.0	41.5	192	96			
	20.0	40.0	41.5	126	84			
24.0	44.0	41.5	108	72				
30.0	45.0	41.5	90	60				

Lead Taping & Packaging (IEC 60286–2)

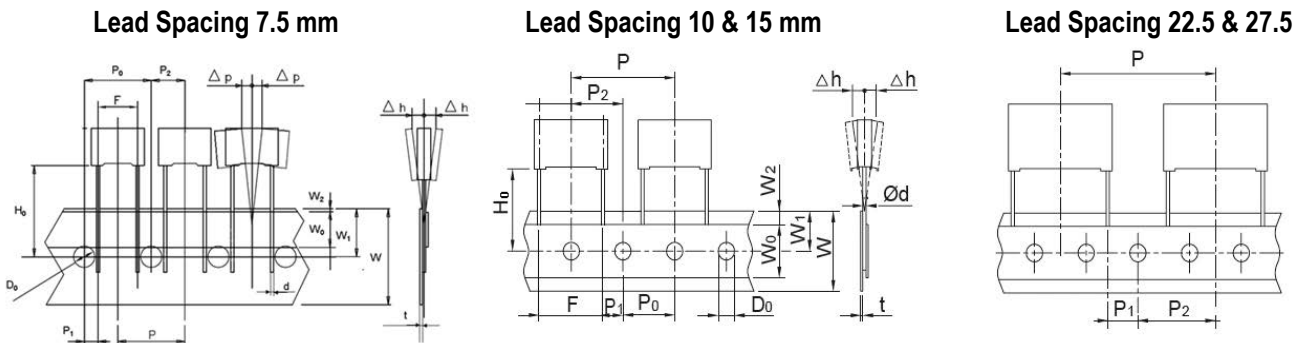

Taping Specification

Description	Symbol	Dimensions (mm)						Tolerance
		Lead Spacing						
		7.5	10.0	15.0	22.5	27.5		
Lead wire diameter	d	0.5 - 0.6	0.6	0.6 - 0.8	0.8	0.8	±0.05	
Taping lead space	P	12.7	25.4	25.4	38.1	38.1	±1	
Feed hole lead space *	P ₀	12.7	12.7	12.7	12.7	12.7	±0.2 **	
Centering of the lead wire	P ₁	2.6	7.7	5.2	7.8	5.3	±0.7	
Centering of the body	P ₂	6.35	12.7	12.7	19.05	19.05	±1.3	
Lead spacing ***	F	7.5	10.0	15.0	22.5	27.5	+0.6/-0.1	
Component alignment	Δh	0	0	0	0	0	±2	
Component deviation	Δp	0	0	0	0	0	±1	
Height of component from tape center	H ₀ ****	18.5	18.5	18.5	18.5	18.5	±0.5	
Carrier tape width	W	18	18	18	18	18	+1/-0.5	
Hold down tape width	W ₀	6	9	10	10	10	Minimum	
Hole position	W ₁	9	9	9	9	9	±0.5	
Hold down tape position	W ₂	3	3	3	3	3	Maximum	
Feed hole diameter	D ₀	4	4	4	4	4	±0.2	
Tape thickness	t	0.7	0.7	0.7	0.7	0.7	±0.2	

* Available also 15 mm.

** Maximum 1 mm on 20 lead spacing.

*** 15 mm and 10 mm taped to 7.5 mm (crimped leads) available upon request.

**** H₀ = 16.5 mm is available upon request.

Lead Taping & Packaging (IEC 60286–2) cont'd

Ammo Specifications

Dimensions (mm)		
H	W	T
360	340	59

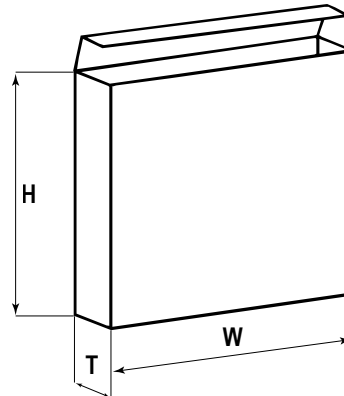

Reel Specifications

Dimensions (mm)		
D	H	W
355	30	55 Maximum
500	25	

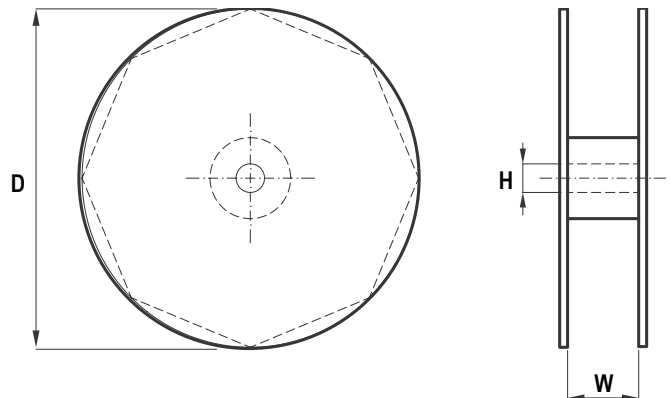

Manufacturing Date Code (IEC–60062)

Y = Year, Z = Month			
Year	Code	Month	Code
2000	M	January	1
2001	N	February	2
2002	P	March	3
2003	R	April	4
2004	S	May	5
2005	T	June	6
2006	U	July	7
2007	V	August	8
2008	W	September	9
2009	X	October	0
2010	A	November	N
2011	B	December	D
2012	C		
2013	D		
2014	E		
2015	F		
2016	H		
2017	J		
2018	K		
2019	L		
2020	M		

KEMET Corporation World Headquarters

2835 KEMET Way
Simpsonville, SC 29681

Mailing Address:
P.O. Box 5928
Greenville, SC 29606

www.kemet.com
Tel: 864-963-6300
Fax: 864-963-6521

Corporate Offices
Fort Lauderdale, FL
Tel: 954-766-2800

North America

Northeast

Wilmington, MA
Tel: 978-658-1663

Southeast

Lake Mary, FL
Tel: 407-855-8886

Central

Novi, MI
Tel: 248-994-1030

Irving, TX
Tel: 972-915-6041

West

Milpitas, CA
Tel: 408-433-9950

Mexico

Guadalajara, Jalisco
Tel: 52-33-3123-2141

Europe

Southern Europe

Sasso Marconi, Italy
Tel: 39-051-939111

Skopje, Macedonia
Tel: 389-2-55-14-623

Central Europe

Landsberg, Germany
Tel: 49-8191-3350800

Kamen, Germany
Tel: 49-2307-438110

Northern Europe

Wyboston, United Kingdom
Tel: 44-1480-273082

Espoo, Finland
Tel: 358-9-5406-5000

Asia

Northeast Asia

Hong Kong
Tel: 852-2305-1168

Shenzhen, China
Tel: 86-755-2518-1306

Beijing, China
Tel: 86-10-5877-1075

Shanghai, China
Tel: 86-21-6447-0707

Seoul, South Korea
Tel: 82-2-6294-0550

Taipei, Taiwan
Tel: 886-2-27528585

Southeast Asia

Singapore
Tel: 65-6701-8033

Penang, Malaysia
Tel: 60-4-6430200

Bangalore, India
Tel: 91-806-53-76817

Note: KEMET reserves the right to modify minor details of internal and external construction at any time in the interest of product improvement. KEMET does not assume any responsibility for infringement that might result from the use of KEMET Capacitors in potential circuit designs. KEMET is a registered trademark of KEMET Electronics Corporation.

Disclaimer

All product specifications, statements, information and data (collectively, the "Information") in this datasheet are subject to change. The customer is responsible for checking and verifying the extent to which the Information contained in this publication is applicable to an order at the time the order is placed.

All Information given herein is believed to be accurate and reliable, but it is presented without guarantee, warranty, or responsibility of any kind, expressed or implied.

Statements of suitability for certain applications are based on KEMET Electronics Corporation's ("KEMET") knowledge of typical operating conditions for such applications, but are not intended to constitute – and KEMET specifically disclaims – any warranty concerning suitability for a specific customer application or use. The Information is intended for use only by customers who have the requisite experience and capability to determine the correct products for their application. Any technical advice inferred from this Information or otherwise provided by KEMET with reference to the use of KEMET's products is given gratis, and KEMET assumes no obligation or liability for the advice given or results obtained.

Although KEMET designs and manufactures its products to the most stringent quality and safety standards, given the current state of the art, isolated component failures may still occur. Accordingly, customer applications which require a high degree of reliability or safety should employ suitable designs or other safeguards (such as installation of protective circuitry or redundancies) in order to ensure that the failure of an electrical component does not result in a risk of personal injury or property damage.

Although all product-related warnings, cautions and notes must be observed, the customer should not assume that all safety measures are indicated or that other measures may not be required.

X-ON Electronics

Largest Supplier of Electrical and Electronic Components

Click to view similar products for [Film Capacitors](#) category:

Click to view products by [Kemet](#) manufacturer:

Other Similar products are found below :

[F339X134748MIP2T0](#) [F450KG153J250ALH0J](#) [750-1018](#) [FKP1-1500160010P15](#) [FKP1R031007D00JYSD](#) [FKP1R031507E00JYSD](#)
[FKP1U024707E00KYSD](#) [82DC4100CK60J](#) [82EC1100DQ50K](#) [PFR5101J100J11L16.5TA18](#) [PME261JB5220KR19T0](#) [A451GK223M040A](#)
[A561ED221M450A](#) [QXJ2E474KTPT](#) [QXL2B333KTPT](#) [R49AN347000A1K](#) [EEC2G505HQA406](#) [B25668A6676A375](#) [B25673A4282E140](#)
[BFC233868148](#) [BFC2370GC222](#) [C3B2AD44400B20K](#) [C4ASWBU3220A3EK](#) [CB027C0473J--](#) [CB177I0184J--](#) [CB182K0184J--](#) [23PW210](#)
[950CQW5H-F](#) [SBDC3470AA10J](#) [SCD105K122A3-22](#) [2N3155](#) [A571EH331M450A](#) [FKP1-2202KV5P15](#) [FKS3-680040010P10](#)
[QXL2E473KTPT](#) [445450-1](#) [B25669A3996J375](#) [46KI322000M1M](#) [46KR415050M1K](#) [4BSNBX4100ZBFJ](#) [MKP383510063JKP2T0](#)
[MKPY2-.02230020P15](#) [MKT 1813-368-015](#) [4055292001](#) [46KN410000N1K](#) [EEC2E106HQA405](#) [EEC2G205HQA402](#) [EEC2G805HQA415](#)
[P409CP224M250AH470](#) [82EC2150DQ50K](#)