

MC10ELT20, MC100ELT20

5V TTL to Differential PECL Translator

Description

The MC10ELT/100ELT20 is a TTL to differential PECL translator. Because PECL (Positive ECL) levels are used, only +5 V and ground are required. The small outline 8-lead package and the single gate of the ELT20 makes it ideal for those applications where space, performance, and low power are at a premium.

The 100 Series contains temperature compensation.

Features

- 1.2 ns Typical Propagation Delay
- PNP TTL Inputs for Minimal Loading
- Flow Through Pinouts
- Operating Range: $V_{CC} = 4.75\text{ V}$ to 5.25 V with $GND = 0\text{ V}$
- These Devices are Pb-Free, Halogen Free/BFR Free and are RoHS Compliant



ON Semiconductor®

www.onsemi.com

MARKING DIAGRAMS*

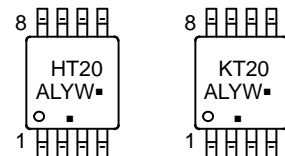
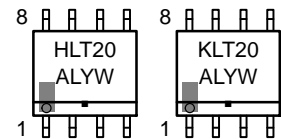

H = MC10
K = MC100

A = Assembly Location
L = Wafer Lot
Y = Year
W = Work Week
■ = Pb-Free Package

(Note: Microdot may be in either location)

*For additional marking information, refer to Application Note AND8002/D.

ORDERING INFORMATION

See detailed ordering and shipping information in the package dimensions section on page 5 of this data sheet.

MC10ELT20, MC100ELT20

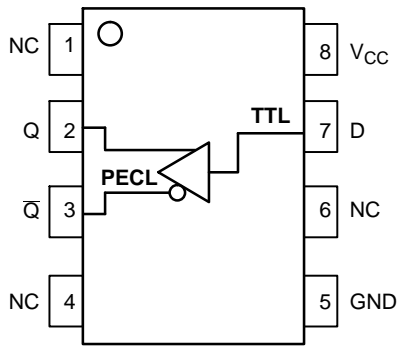

Figure 1. 8-Lead Pinout (Top View) and Logic Diagram

Table 1. PIN DESCRIPTION

Pin	Function
Q, \bar{Q}	PECL Differential Outputs*
D	TTL Input
V _{CC}	Positive Supply
GND	Ground
NC	No Connect

*Output state undetermined when inputs are open.

Table 2. ATTRIBUTES

Characteristics	Value
Internal Input Pulldown Resistor	N/A
Internal Input Pullup Resistor	N/A
ESD Protection	Human Body Model Machine Model > 4 kV > 200 V
Moisture Sensitivity, Indefinite Time Out of Drypack (Note 1)	Pb-Free Pkg
	SO-8 TSSOP-8 Level 1 Level 3
Flammability Rating	Oxygen Index: 28 to 34 UL 94 V-0 @ 0.125 in
Transistor Count	51 Devices
Meets or exceeds JEDEC Spec EIA/JESD78 IC Latchup Test	

1. For additional information, see Application Note AND8003/D.

Table 3. MAXIMUM RATINGS

Symbol	Parameter	Condition 1	Condition 2	Rating	Unit
V _{CC}	Positive Power Supply	GND = 0 V		7	V
V _{IN}	Input Voltage	GND = 0 V	V _I ≤ V _{CC}	7	V
I _{out}	Output Current	Continuous Surge		50 100	mA mA
T _A	Operating Temperature Range			-40 to +85	°C
T _{stg}	Storage Temperature Range			-65 to +150	°C
θ _{JA}	Thermal Resistance (Junction-to-Ambient)	0 lfpm 500 lfpm	SO-8 SO-8	190 130	°C/W °C/W
θ _{JC}	Thermal Resistance (Junction-to-Case)	Standard Board	SO-8	41 to 44	°C/W
θ _{JA}	Thermal Resistance (Junction-to-Ambient)	0 lfpm 500 lfpm	TSSOP-8 TSSOP-8	185 140	°C/W °C/W
θ _{JC}	Thermal Resistance (Junction-to-Case)	Standard Board	TSSOP-8	41 to 44	°C/W
T _{sol}	Wave Solder	Pb-Free < 3 s @ 260°C		265	°C

Stresses exceeding those listed in the Maximum Ratings table may damage the device. If any of these limits are exceeded, device functionality should not be assumed, damage may occur and reliability may be affected.

MC10ELT20, MC100ELT20

Table 4. 10ELT SERIES PECL DC CHARACTERISTICS $V_{CC} = 5.0\text{ V}$; $GND = 0.0\text{ V}$ (Note 2)

Symbol	Characteristic	-40°C			25°C			85°C			Unit
		Min	Typ	Max	Min	Typ	Max	Min	Typ	Max	
I_{CC}	Power Supply Current			16			16			16	mA
V_{OH}	Output HIGH Voltage (Note 3)	3920	4010	4110	4020	4105	4190	4090	4185	4280	mV
V_{OL}	Output LOW Voltage (Note 3)	3050	3200	3350	3050	3210	3370	3050	3227	3405	mV

NOTE: Device will meet the specifications after thermal equilibrium has been established when mounted in a test socket or printed circuit board with maintained transverse airflow greater than 500 lfm.

2. Output parameters vary 1:1 with V_{CC} . V_{CC} can vary $\pm 0.25\text{ V}$.
3. Outputs are terminated through a $50\ \Omega$ resistor to $V_{CC} - 2\text{ V}$.

Table 5. 100ELT SERIES PECL DC CHARACTERISTICS $V_{CC} = 5.0\text{ V}$; $GND = 0.0\text{ V}$ (Note 4)

Symbol	Characteristic	-40°C			25°C			85°C			Unit
		Min	Typ	Max	Min	Typ	Max	Min	Typ	Max	
I_{CC}	Power Supply Current			16			16			16	mA
V_{OH}	Output HIGH Voltage (Note 5)	3915	3995	4120	3975	4045	4120	3975	4050	4120	mV
V_{OL}	Output LOW Voltage (Note 5)	3170	3305	3445	3190	3295	3380	3190	3295	3380	mV
I_{IH}	Input HIGH Current			150			150			150	μA
I_{IL}	Input LOW Current	0.5			0.5			0.5			μA

NOTE: Device will meet the specifications after thermal equilibrium has been established when mounted in a test socket or printed circuit board with maintained transverse airflow greater than 500 lfm.

4. Output parameters vary 1:1 with V_{CC} . V_{CC} can vary $\pm 0.25\text{ V}$.
5. Outputs are terminated through a $50\ \Omega$ resistor to $V_{CC} - 2\text{ V}$.

Table 6. TTL INPUT DC CHARACTERISTICS $V_{CC} = 4.7\text{ V}$ to 5.27 V ; $T_A = -40^\circ\text{C}$ to 85°C

Symbol	Characteristic	Condition	Min	Typ	Max	Unit
I_{IH}	Input HIGH Current	$V_{IN} = 2.7\text{ V}$			20	μA
I_{IHH}	Input HIGH Current	$V_{IN} = 7.0\text{ V}$			100	μA
I_{IL}	Input LOW Current	$V_{IN} = 0.5\text{ V}$			-0.6	mA
V_{IK}	Input Clamp Diode Voltage	$I_{IN} = -18\text{ mA}$			-1.2	V
V_{IH}	Input HIGH Voltage		2.0			V
V_{IL}	Input LOW Voltage				0.8	V

NOTE: Device will meet the specifications after thermal equilibrium has been established when mounted in a test socket or printed circuit board with maintained transverse airflow greater than 500 lfm.

MC10ELT20, MC100ELT20

Table 7. AC CHARACTERISTICS $V_{CC} = 4.75\text{ V to }5.25\text{ V}$; $GND = 0.0\text{ V}$

Symbol	Characteristic	-40°C			25°C			85°C			Unit
		Min	Typ	Max	Min	Typ	Max	Min	Typ	Max	
f_{max}	Maximum Toggle Frequency	100			100			100			MHz
t_{PLH}	Propagation Delay 1.5 V to 50%	0.6	0.82	1.2	0.6	0.82	1.25	0.6	0.83	1.35	ns
t_{PHL}	Propagation Delay 1.5 V to 50%	0.4		1.0	0.5	0.8	1.1	0.7		1.30	ns
t_{JITTER}	Cycle-to-Cycle Jitter		TBD			TBD			TBD		ps
t_r/t_f	Output Rise/Fall Time (20–80%)	0.15		1.5	0.15		1.5	0.15		1.5	ns

NOTE: Device will meet the specifications after thermal equilibrium has been established when mounted in a test socket or printed circuit board with maintained transverse airflow greater than 500 lfpm.

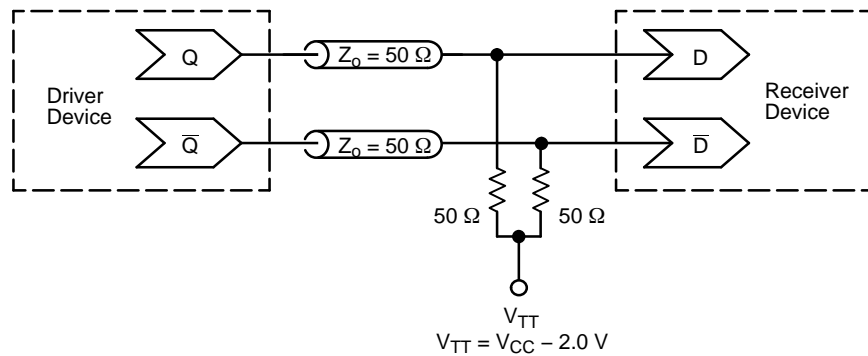

Figure 2. Typical Termination for Output Driver and Device Evaluation
(See Application Note AND8020/D – Termination of ECL Logic Devices.)

MC10ELT20, MC100ELT20

ORDERING INFORMATION

Device	Package	Shipping†
MC10ELT20DG	SO-8 (Pb-Free)	98 Units / Rail
MC10ELT20DR2G	SO-8 (Pb-Free)	2500 / Tape & Reel
MC10ELT20DTG	TSSOP-8 (Pb-Free)	100 Units / Rail
MC10ELT20DTR2G	TSSOP-8 (Pb-Free)	2500 / Tape & Reel
MC100ELT20DG	SO-8 (Pb-Free)	98 Units / Rail
MC100ELT20DR2G	SO-8 (Pb-Free)	2500 / Tape & Reel
MC100ELT20DTG	TSSOP-8 (Pb-Free)	100 Units / Rail
MC100ELT20DTR2G	TSSOP-8 (Pb-Free)	2500 / Tape & Reel

†For information on tape and reel specifications, including part orientation and tape sizes, please refer to our Tape and Reel Packaging Specifications Brochure, BRD8011/D.

Resource Reference of Application Notes

- AN1405/D** – ECL Clock Distribution Techniques
- AN1406/D** – Designing with PECL (ECL at +5.0 V)
- AN1503/D** – ECLinPS™ I/O SPiCE Modeling Kit
- AN1504/D** – Metastability and the ECLinPS Family
- AN1568/D** – Interfacing Between LVDS and ECL
- AN1672/D** – The ECL Translator Guide
- AND8001/D** – Odd Number Counters Design
- AND8002/D** – Marking and Date Codes
- AND8020/D** – Termination of ECL Logic Devices
- AND8066/D** – Interfacing with ECLinPS
- AND8090/D** – AC Characteristics of ECL Devices

MC10ELT20, MC100ELT20

PACKAGE DIMENSIONS

SOIC-8 NB
CASE 751-07
ISSUE AK

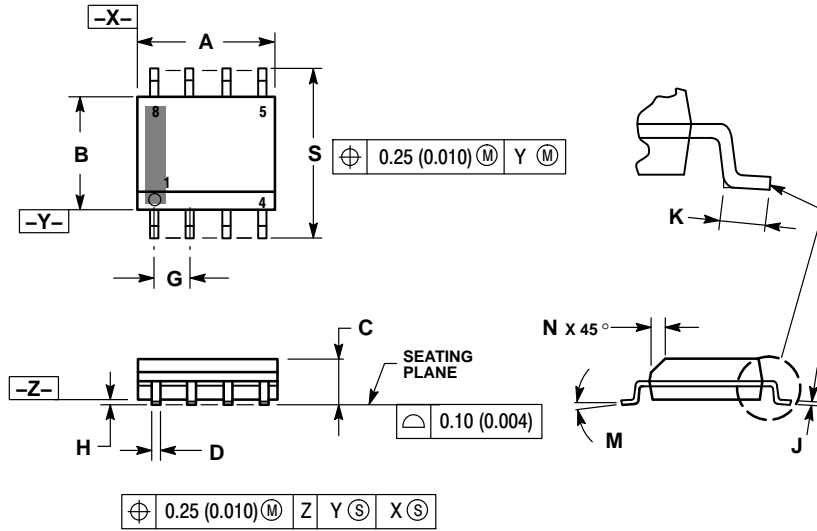

NOTES:

1. DIMENSIONING AND TOLERANCING PER ANSI Y14.5M, 1982.
2. CONTROLLING DIMENSION: MILLIMETER.
3. DIMENSION A AND B DO NOT INCLUDE MOLD PROTRUSION.
4. MAXIMUM MOLD PROTRUSION 0.15 (0.006) PER SIDE.
5. DIMENSION D DOES NOT INCLUDE DAMBAR PROTRUSION. ALLOWABLE DAMBAR PROTRUSION SHALL BE 0.127 (0.005) TOTAL IN EXCESS OF THE D DIMENSION AT MAXIMUM MATERIAL CONDITION.
6. 751-01 THRU 751-06 ARE OBSOLETE. NEW STANDARD IS 751-07.

DIM	MILLIMETERS		INCHES	
	MIN	MAX	MIN	MAX
A	4.80	5.00	0.189	0.197
B	3.80	4.00	0.150	0.157
C	1.35	1.75	0.053	0.069
D	0.33	0.51	0.013	0.020
G	1.27 BSC		0.050 BSC	
H	0.10	0.25	0.004	0.010
J	0.19	0.25	0.007	0.010
K	0.40	1.27	0.016	0.050
M	0°	8°	0°	8°
N	0.25	0.50	0.010	0.020
S	5.80	6.20	0.228	0.244

SOLDERING FOOTPRINT*

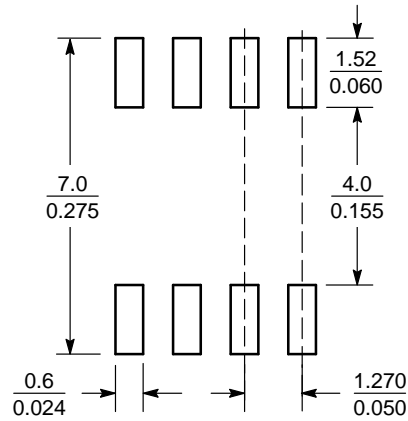

SCALE 6:1 $\left(\frac{\text{mm}}{\text{inches}}\right)$

*For additional information on our Pb-Free strategy and soldering details, please download the ON Semiconductor Soldering and Mounting Techniques Reference Manual, SOLDERRM/D.

MC10ELT20, MC100ELT20

PACKAGE DIMENSIONS

TSSOP-8
DT SUFFIX
CASE 948R-02
ISSUE A

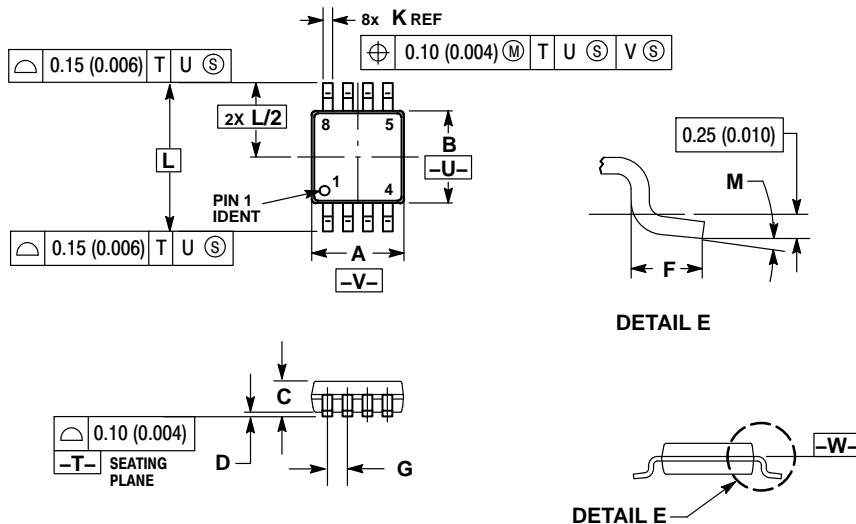

- NOTES:
1. DIMENSIONING AND TOLERANCING PER ANSI Y14.5M, 1982.
 2. CONTROLLING DIMENSION: MILLIMETER.
 3. DIMENSION A DOES NOT INCLUDE MOLD FLASH. PROTRUSIONS OR GATE BURRS. MOLD FLASH OR GATE BURRS SHALL NOT EXCEED 0.15 (0.006) PER SIDE.
 4. DIMENSION B DOES NOT INCLUDE INTERLEAD FLASH OR PROTRUSION. INTERLEAD FLASH OR PROTRUSION SHALL NOT EXCEED 0.25 (0.010) PER SIDE.
 5. TERMINAL NUMBERS ARE SHOWN FOR REFERENCE ONLY.
 6. DIMENSION A AND B ARE TO BE DETERMINED AT DATUM PLANE -V-.

DIM	MILLIMETERS		INCHES	
	MIN	MAX	MIN	MAX
A	2.90	3.10	0.114	0.122
B	2.90	3.10	0.114	0.122
C	0.80	1.10	0.031	0.043
D	0.05	0.15	0.002	0.006
F	0.40	0.70	0.016	0.028
G	0.65 BSC		0.026 BSC	
K	0.25	0.40	0.010	0.016
L	4.90 BSC		0.193 BSC	
M	0°	6°	0°	6°

ECLinPS is a trademark of Semiconductor Components Industries, LLC (SCILLC).

ON Semiconductor and the  are registered trademarks of Semiconductor Components Industries, LLC (SCILLC) or its subsidiaries in the United States and/or other countries. SCILLC owns the rights to a number of patents, trademarks, copyrights, trade secrets, and other intellectual property. A listing of SCILLC's product/patent coverage may be accessed at www.onsemi.com/site/pdf/Patent-Marking.pdf. SCILLC reserves the right to make changes without further notice to any products herein. SCILLC makes no warranty, representation or guarantee regarding the suitability of its products for any particular purpose, nor does SCILLC assume any liability arising out of the application or use of any product or circuit, and specifically disclaims any and all liability, including without limitation special, consequential or incidental damages. "Typical" parameters which may be provided in SCILLC data sheets and/or specifications can and do vary in different applications and actual performance may vary over time. All operating parameters, including "Typicals" must be validated for each customer application by customer's technical experts. SCILLC does not convey any license under its patent rights nor the rights of others. SCILLC products are not designed, intended, or authorized for use as components in systems intended for surgical implant into the body, or other applications intended to support or sustain life, or for any other application in which the failure of the SCILLC product could create a situation where personal injury or death may occur. Should Buyer purchase or use SCILLC products for any such unintended or unauthorized application, Buyer shall indemnify and hold SCILLC and its officers, employees, subsidiaries, affiliates, and distributors harmless against all claims, costs, damages, and expenses, and reasonable attorney fees arising out of, directly or indirectly, any claim of personal injury or death associated with such unintended or unauthorized use, even if such claim alleges that SCILLC was negligent regarding the design or manufacture of the part. SCILLC is an Equal Opportunity/Affirmative Action Employer. This literature is subject to all applicable copyright laws and is not for resale in any manner.

PUBLICATION ORDERING INFORMATION

LITERATURE FULFILLMENT:
Literature Distribution Center for ON Semiconductor
19521 E. 32nd Pkwy, Aurora, Colorado 80011 USA
Phone: 303-675-2175 or 800-344-3860 Toll Free USA/Canada
Fax: 303-675-2176 or 800-344-3867 Toll Free USA/Canada
Email: orderlit@onsemi.com

N. American Technical Support: 800-282-9855 Toll Free
USA/Canada
Europe, Middle East and Africa Technical Support:
Phone: 421 33 790 2910
Japan Customer Focus Center
Phone: 81-3-5817-1050

ON Semiconductor Website: www.onsemi.com

Order Literature: <http://www.onsemi.com/orderlit>

For additional information, please contact your local Sales Representative

X-ON Electronics

Largest Supplier of Electrical and Electronic Components

Click to view similar products for [Translation - Voltage Levels](#) category:

Click to view products by [ON Semiconductor](#) manufacturer:

Other Similar products are found below :

[NLJVHC1GT08DFT2G](#) [NLSX4373DMR2G](#) [NLSX5012MUTAG](#) [HV583GA-G](#) [MC10H641FNR2G](#) [NLSX0102FCT1G](#) [NLSX0102FCT2G](#)
[NLSX4302EBMUTCG](#) [NLVSX4373DR2G](#) [PCA9306FMUTAG](#) [SY10H351JZ](#) [MC100EPT622MNG](#) [MAX9376EUB+T](#) [MAX9374AEKA+T](#)
[MAX3378EETD+](#) [MAX34405BEZT+](#) [NLSX3014MUTAG](#) [NVT4556BUKZ](#) [NLSV4T244EMUTAG](#) [NLSX5011MUTCG](#) [NLV9306USG](#)
[NLVSX4014MUTAG](#) [MAX34405BEZT+T](#) [NLSV4T3144MUTAG](#) [NSV12200LT1G](#) [NLVSX4373MUTAG](#) [NB3U23CMNTAG](#)
[MAX3371ELT+T](#) [MAX3008EUP+T](#) [NLVPCA9306AMUTCG](#) [NLSX3013BFCT1G](#) [MAX9378EUA+T](#) [NLV7WBD3125USG](#)
[NLV14504BDTG](#) [NLSX3012DMR2G](#) [NLSX5012DR2G](#) [MAX3391EEUD+T](#) [MAX3379EETD+](#) [PI4ULS3V4857GEAEX](#)
[MAX3391EEBC+T](#) [MAX14842ATE+T](#) [74AVCH1T45FZ4-7](#) [CLVC16T245MDGGREP](#) [HEF4104BT](#) [TC74LCX16245\(EL,F\)](#)
[MC10H124FNG](#) [CAVCB164245MDGGREP](#) [7WBD383USG](#) [NVT2001GM,115](#) [CLVC8T245MRHLTEP](#)