

MC74VHC259

8-Bit Addressable Latch/1-of-8 Decoder CMOS Logic Level Shifter with LSTTL-Compatible Inputs

The MC74VHC259 is an 8-bit Addressable Latch fabricated with silicon gate CMOS technology. It achieves high speed operation similar to equivalent Bipolar Schottky TTL devices while maintaining CMOS low power dissipation.

The VHC259 is designed for general purpose storage applications in digital systems. The device has four modes of operation as shown in the mode selection table. In the addressable latch mode, the data on Data In is written into the addressed latch. The addressed latch follows the data input with all non-addressed latches remaining in their previous states. In the memory mode, all latches remain in their previous state and are unaffected by the Data or Address inputs. In the one-of-eight decoding or demultiplexing mode, the addressed output follows the state of Data In with all other outputs in the LOW state. In the Reset mode, all outputs are LOW and unaffected by the address and data inputs. When operating the VHC259 as an addressable latch, changing more than one bit of the address could impose a transient wrong address. Therefore, this should only be done while in the memory mode.

The MC74VHC259 input structure provides protection when voltages up to 7 V are applied, regardless of the supply voltage. This allows the MC74VHC259 to be used to interface 5 V circuits to 3 V circuits.

- High Speed: $t_{PD} = 7.6 \text{ ns}$ (Typ) at $V_{CC} = 5 \text{ V}$
- Low Power Dissipation: $I_{CC} = 2 \mu\text{A}$ (Max) at $T_A = 25^\circ\text{C}$
- High Noise Immunity: $V_{NIH} = V_{NIL} = 28\% V_{CC}$
- CMOS-Compatible Outputs: $V_{OH} > 0.8 V_{CC}$; $V_{OL} < 0.1 V_{CC}$ @Load
- Power Down Protection Provided on Inputs and Outputs
- Balanced Propagation Delays
- Pin and Function Compatible with Other Standard Logic Families
- Latchup Performance Exceeds 300 mA
- ESD Performance: HBM > 2000 V
- These Devices are Pb-Free and are RoHS Compliant

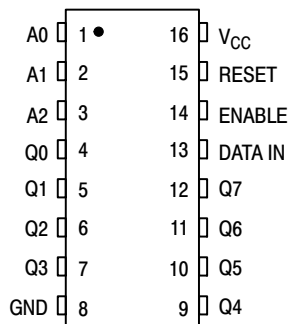

Figure 1. Pin Assignment



ON Semiconductor™

<http://onsemi.com>

MARKING DIAGRAMS

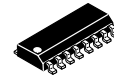

SOIC-16
D SUFFIX
CASE 751B



TSSOP-16
DT SUFFIX
CASE 948F

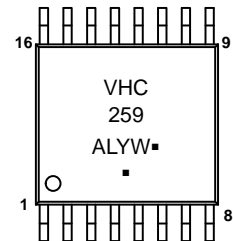

A = Assembly Location
L, WL = Wafer Lot
Y, YY = Year
W, WW = Work Week
G or ■ = Pb-Free Package

ORDERING INFORMATION

| Device | Package | Shipping |
|-----------------|----------|-----------------|
| MC74VHC259DG | SOIC-16 | 48 Units/Rail |
| MC74VHC259DR2G | SOIC-16 | 2500 Units/Reel |
| MC74VHC259DTG | TSSOP-16 | 96 Units/Rail |
| MC74VHC259DTR2G | TSSOP-16 | 2500 Units/Reel |

MC74VHC259

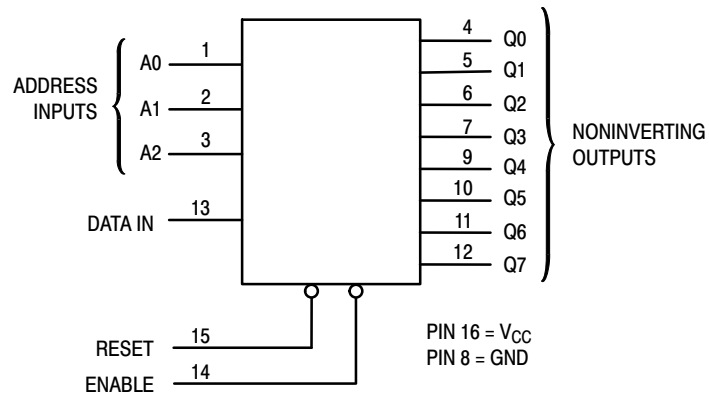

Figure 2. Logic Diagram

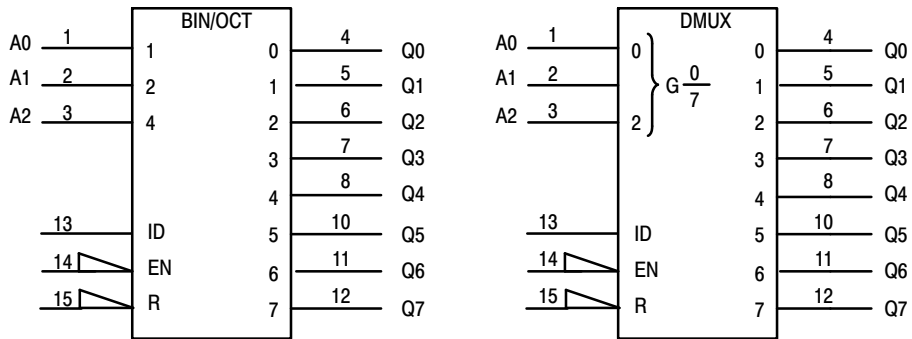

Figure 3. IEC Logic Symbol

LATCH SELECTION TABLE

| Address Inputs | | | Latch Addressed |
|----------------|---|---|-----------------|
| C | B | A | |
| L | L | L | Q0 |
| L | L | H | Q1 |
| L | H | L | Q2 |
| L | H | H | Q3 |
| H | L | L | Q4 |
| H | L | H | Q5 |
| H | H | L | Q6 |
| H | H | H | Q7 |

MODE SELECTION TABLE

| Enable | Reset | Mode |
|--------|-------|----------------------|
| L | H | Addressable Latch |
| H | H | Memory |
| L | L | 8-Line Demultiplexer |
| H | L | Reset |

MC74VHC259

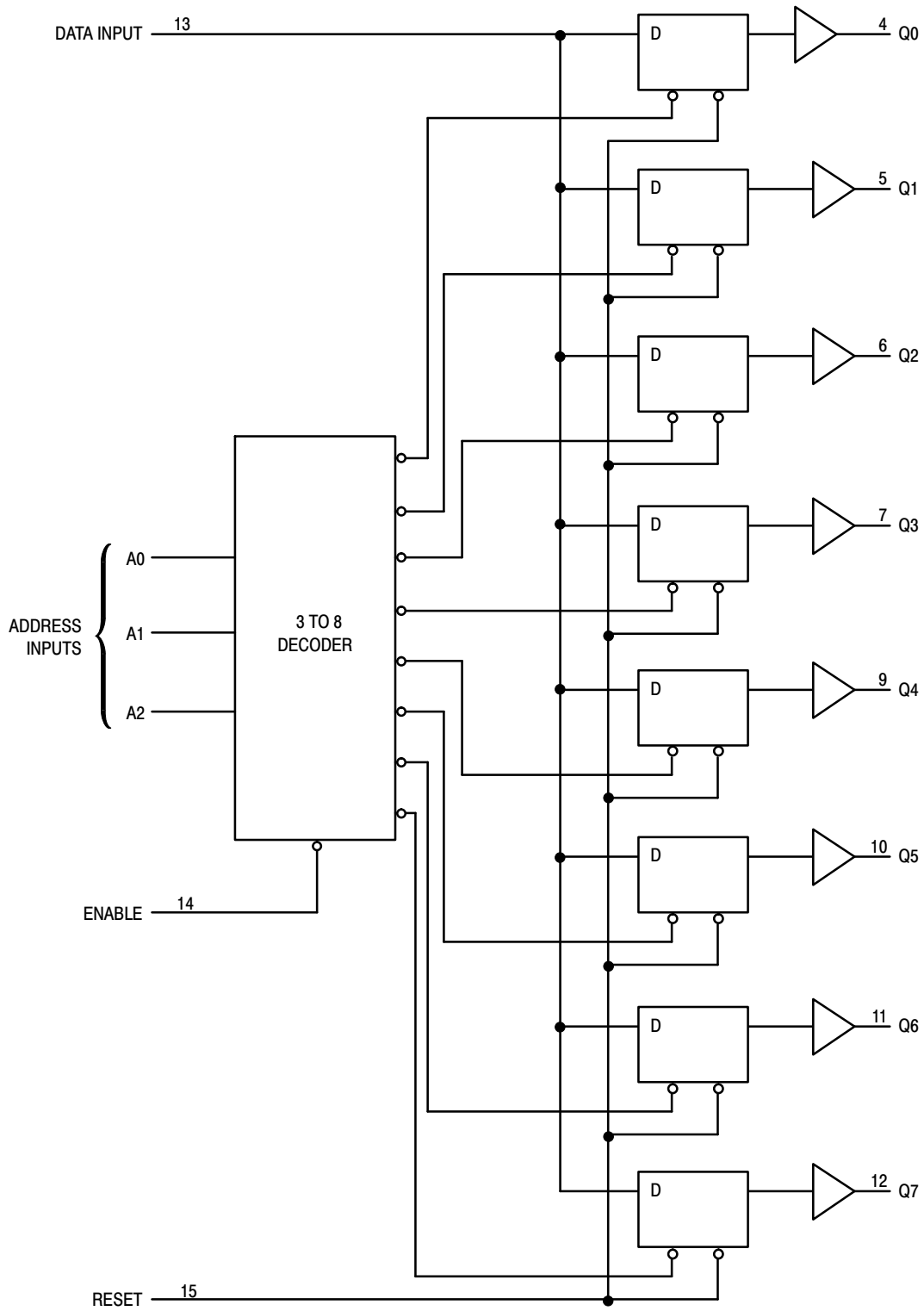

Figure 4. Expanded Logic Diagram

MC74VHC259

MAXIMUM RATINGS

| Symbol | Parameter | Value | Unit | |
|-----------------------|---|---|------------------------|------|
| V _{CC} | Positive DC Supply Voltage | -0.5 to +7.0 | V | |
| V _{IN} | Digital Input Voltage | -0.5 to +7.0 | V | |
| V _{OUT} | DC Output Voltage | -0.5 to V _{CC} +0.5 | V | |
| I _{IK} | Input Diode Current | -20 | mA | |
| I _{OK} | Output Diode Current | ± 20 | mA | |
| I _{OUT} | DC Output Current, per Pin | ± 25 | mA | |
| I _{CC} | DC Supply Current, V _{CC} and GND Pins | ± 75 | mA | |
| P _D | Power Dissipation in Still Air | SOIC Package TSSOP | 200 180 | mW |
| T _{STG} | Storage Temperature Range | -65 to +150 | °C | |
| V _{ESD} | ESD Withstand Voltage | Human Body Model (Note 1.) Machine Model (Note 2.) Charged Device Model (Note 3.) | >2000 >200 >2000 | V |
| I _{LATCH-UP} | Latch-Up Performance | Above V _{CC} and Below GND at 125°C (Note 4.) | ± 300 | mA |
| θ _{JA} | Thermal Resistance, Junction to Ambient | SOIC Package TSSOP | 143 164 | °C/W |

Stresses exceeding those listed in the Maximum Ratings table may damage the device. If any of these limits are exceeded, device functionality should not be assumed, damage may occur and reliability may be affected.

1. Tested to EIA/JESD22-A114-A
2. Tested to EIA/JESD22-A115-A
3. Tested to JESD22-C101-A
4. Tested to EIA/JESD78

RECOMMENDED OPERATING CONDITIONS

| Symbol | Characteristics | Min | Max | Unit | |
|---------------------------------|--|--|-----------------|------|------|
| V _{CC} | DC Supply Voltage | 2.0 | 5.5 | V | |
| V _{IN} | DC Input Voltage | 0 | 5.5 | V | |
| V _{OUT} | DC Output Voltage | 0 | V _{CC} | V | |
| T _A | Operating Temperature Range, all Package Types | -55 | 125 | °C | |
| t _r , t _f | Input Rise or Fall Time | V _{CC} = 3.3 V ± 0.3 V V _{CC} = 5.0 V ± 0.5 V | 0 | 20 | ns/V |

Functional operation above the stresses listed in the Recommended Operating Ranges is not implied. Extended exposure to stresses beyond the Recommended Operating Ranges limits may affect device reliability.

DEVICE JUNCTION TEMPERATURE VERSUS TIME TO 0.1% BOND FAILURES

| Junction Temperature °C | Time, Hours | Time, Years |
|-------------------------|-------------|-------------|
| 80 | 1,032,200 | 117.8 |
| 90 | 419,300 | 47.9 |
| 100 | 178,700 | 20.4 |
| 110 | 79,600 | 9.4 |
| 120 | 37,000 | 4.2 |
| 130 | 17,800 | 2.0 |
| 140 | 8,900 | 1.0 |

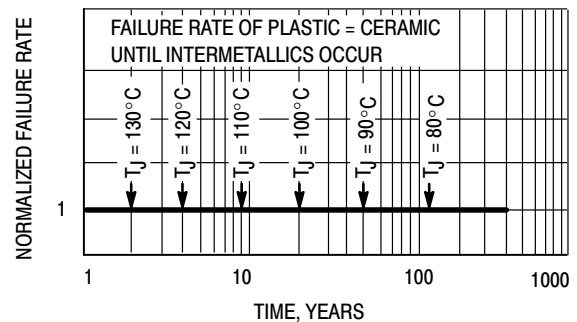

Figure 5. Failure Rate vs. Time Junction Temperature

MC74VHC259

DC CHARACTERISTICS (Voltages Referenced to GND)

| Symbol | Parameter | Condition | V _{CC} (V) | T _A = 25°C | | | -55°C ≤ T _A ≤ 125°C | | Unit |
|-----------------|-----------------------------------|--|------------------------|-----------------------------|-------------------|-----------------------------|--------------------------------|-----------------------------|------|
| | | | | Min | Typ | Max | Min | Max | |
| V _{IH} | Minimum High-Level Input Voltage | | 2.0 3.0 to 5.5 | 1.5 V _{CCX} 0.7 | | | 1.5 V _{CCX} 0.7 | | V |
| V _{IL} | Maximum Low-Level Input Voltage | | 2.0 3.0 to 5.5 | | | 0.5 V _{CCX} 0.3 | | 0.5 V _{CCX} 0.3 | V |
| V _{OH} | Maximum High-Level Output Voltage | V _{IN} = V _{IH} or V _{IL} I _{OH} = -50 μA | 2.0 3.0 4.5 | 1.9 2.9 4.4 | 2.0 3.0 4.5 | | 1.9 2.9 4.4 | | V |
| | | V _{IN} = V _{IH} or V _{IL} I _{OL} = 4 mA I _{OL} = 8 mA | 3.0 4.5 | 2.58 3.94 | | | 2.48 3.8 | | V |
| V _{OL} | Maximum Low-Level Output Voltage | V _{IN} = V _{IH} or V _{IL} I _{OL} = 50 μA | 2.0 3.0 4.5 | | 0.0 0.0 0.0 | 0.1 0.1 0.1 | | 0.1 0.1 0.1 | V |
| | | V _{IN} = V _{IH} or V _{IL} I _{OL} = 4 mA I _{OL} = 8 mA | 3.0 4.5 | | 0.36 0.36 | | | 0.44 0.44 | V |
| I _{IN} | Input Leakage Current | V _{IN} = 5.5 V or GND | 0 to 5.5 | | | ±0.1 | | ±1.0 | μA |
| I _{CC} | Maximum Quiescent Supply Current | V _{IN} = V _{CC} or GND | 5.5 | | | 4.0 | | 40.0 | μA |

Product parametric performance is indicated in the Electrical Characteristics for the listed test conditions, unless otherwise noted. Product performance may not be indicated by the Electrical Characteristics if operated under different conditions.

AC ELECTRICAL CHARACTERISTICS (Input t_r = t_f = 3.0ns)

| Symbol | Parameter | Test Conditions | T _A = 25°C | | | T _A ≤ 85°C | | -55°C ≤ T _A ≤ 125°C | | Unit |
|--|--|--|-----------------------|-----|------|-----------------------|------|--------------------------------|------|------|
| | | | Min | Typ | Max | Min | Max | Min | Max | |
| t _{PLH} , t _{PHL} | Maximum Propagation Delay, Data to Output (Figures 6 and 11) | V _{CC} = 3.3 ± 0.3V C _L = 15pF | | 6.0 | 8.5 | 1.0 | 11.5 | 1.0 | 11.5 | ns |
| | | V _{CC} = 5.0 ± 0.5V C _L = 50pF | | 8.5 | 12.5 | 1.0 | 14.5 | 1.0 | 14.5 | |
| t _{PLH} , t _{PHL} | Maximum Propagation Delay, Address Select to Output (Figures 7 and 11) | V _{CC} = 3.3 ± 0.3V C _L = 15pF | | 6.0 | 8.5 | 1.0 | 11.5 | 1.0 | 11.5 | ns |
| | | V _{CC} = 5.0 ± 0.5V C _L = 50pF | | 8.5 | 12.5 | 1.0 | 14.5 | 1.0 | 14.5 | |
| t _{PLH} , t _{PHL} | Maximum Propagation Delay, Enable to Output (Figures 8 and 11) | V _{CC} = 3.3 ± 0.3V C _L = 15pF | | 6.0 | 8.5 | 1.0 | 11.5 | 1.0 | 11.5 | ns |
| | | V _{CC} = 5.0 ± 0.5V C _L = 50pF | | 8.5 | 12.5 | 1.0 | 14.5 | 1.0 | 14.5 | |
| t _{PHL} | Maximum Propagation Delay, Reset to Output (Figures 9 and 11) | V _{CC} = 3.3 ± 0.3V C _L = 15pF | | 6.0 | 8.5 | 1.0 | 11.5 | 1.0 | 11.5 | ns |
| | | V _{CC} = 5.0 ± 0.5V C _L = 50pF | | 8.5 | 12.5 | 1.0 | 14.5 | 1.0 | 14.5 | |
| C _{IN} | Maximum Input Capacitance | V _{CC} = 3.3 ± 0.3V C _L = 15pF | | 6 | 10 | | 10 | | 10 | pF |
| | | V _{CC} = 5.0 ± 0.5V C _L = 50pF | | 6 | 10 | | 10 | | 10 | |

| C _{PD} | Power Dissipation Capacitance (Note 1) | Typical @ 25°C, V _{CC} = 5.0V | | pF |
|-----------------|--|--|-----|----|
| | | Min | Max | |
| | | | 30 | |

1. C_{PD} is defined as the value of the internal equivalent capacitance which is calculated from the operating current consumption without load. Average operating current can be obtained by the equation: I_{CC(OPR)} = C_{PD} • V_{CC} • f_{in} + I_{CC}. C_{PD} is used to determine the no-load dynamic power consumption; P_D = C_{PD} • V_{CC}² • f_{in} + I_{CC} • V_{CC}.

MC74VHC259

TIMING REQUIREMENTS (Input $t_r = t_f = 3.0\text{ns}$)

| Symbol | Parameter | Test Conditions | $T_A = 25^\circ\text{C}$ | | | $T_A \leq 85^\circ\text{C}$ | | $T_A \leq 125^\circ\text{C}$ | | Unit |
|------------|--|--------------------------------|--------------------------|-----|-----|-----------------------------|-----|------------------------------|-----|------|
| | | | Min | Typ | Max | Min | Max | Min | Max | |
| t_w | Minimum Pulse Width, Reset or Enable (Figure 10) | $V_{CC} = 3.3 \pm 0.3\text{V}$ | 5.0 | | | 5.5 | | 5.5 | | ns |
| | | $V_{CC} = 5.0 \pm 0.5\text{V}$ | 5.0 | | | 5.5 | | 5.5 | | |
| t_{su} | Minimum Setup Time, Address or Data to Enable (Figure 10) | $V_{CC} = 3.3 \pm 0.3\text{V}$ | 4.5 | | | 4.5 | | 4.5 | | ns |
| | | $V_{CC} = 5.0 \pm 0.5\text{V}$ | 3.0 | | | 3.0 | | 3.0 | | |
| t_h | Minimum Hold Time, Enable to Address or Data (Figure 8 or 9) | $V_{CC} = 3.3 \pm 0.3\text{V}$ | 2.0 | | | 2.0 | | 2.0 | | ns |
| | | $V_{CC} = 5.0 \pm 0.5\text{V}$ | 2.0 | | | 2.0 | | 2.0 | | |
| t_r, t_f | Maximum Input, Rise and Fall Times (Figure 6) | $V_{CC} = 3.3 \pm 0.3\text{V}$ | | | 400 | | 300 | | 300 | ns |
| | | $V_{CC} = 5.0 \pm 0.5\text{V}$ | | | 200 | | 100 | | 100 | |

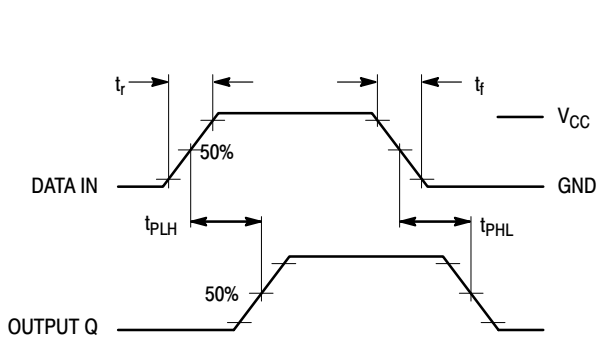

Figure 6. Switching Waveform

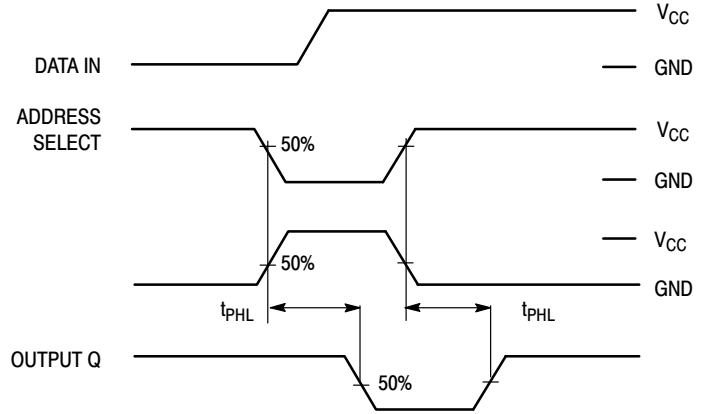

Figure 7. Switching Waveform

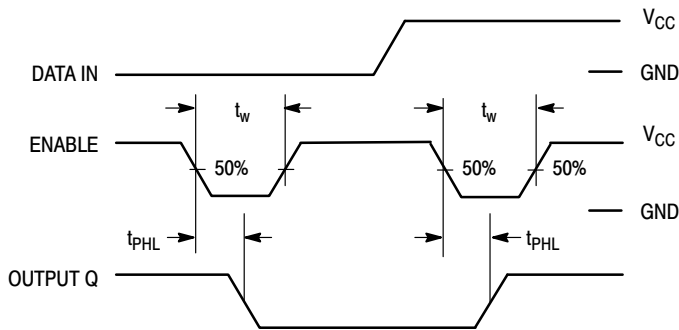

Figure 8. Switching Waveform

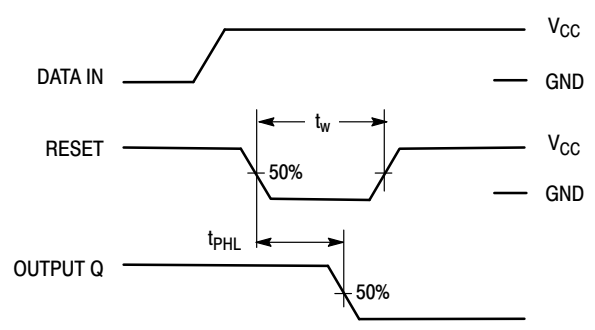

Figure 9. Switching Waveform

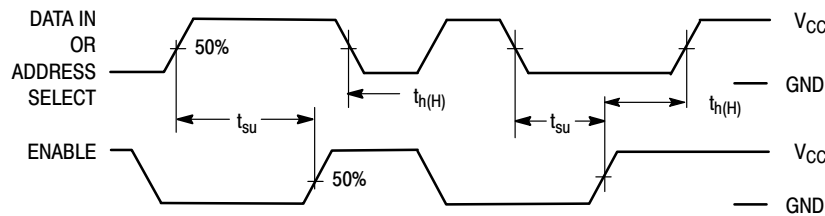
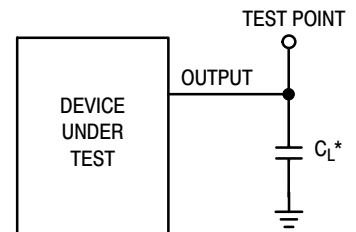

Figure 10. Switching Waveform



*Includes all probe and jig capacitance

Figure 11. Test Circuit

MC74VHC259

PACKAGE DIMENSIONS

SOIC-16
CASE 751B-05
ISSUE K

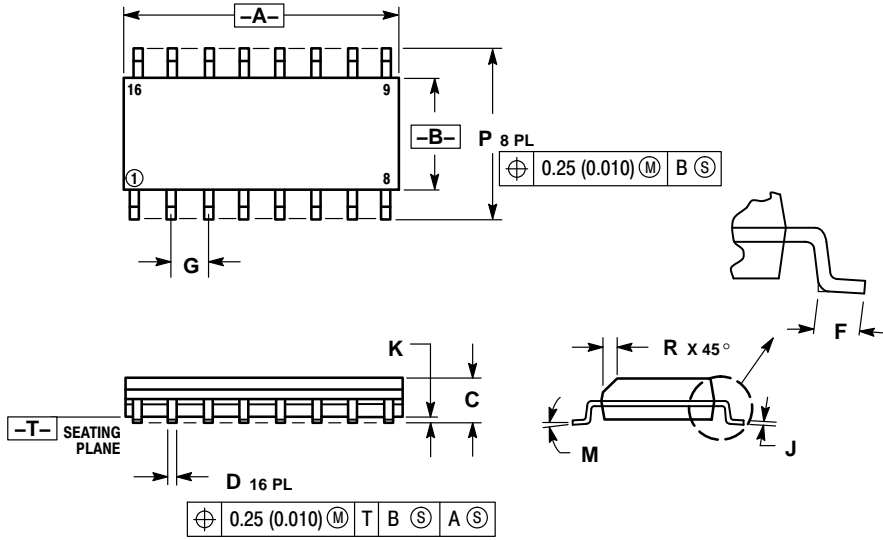

NOTES:

1. DIMENSIONING AND TOLERANCING PER ANSI Y14.5M, 1982.
2. CONTROLLING DIMENSION: MILLIMETER.
3. DIMENSIONS A AND B DO NOT INCLUDE MOLD PROTRUSION.
4. MAXIMUM MOLD PROTRUSION 0.15 (0.006) PER SIDE.
5. DIMENSION D DOES NOT INCLUDE DAMBAR PROTRUSION. ALLOWABLE DAMBAR PROTRUSION SHALL BE 0.127 (0.005) TOTAL IN EXCESS OF THE D DIMENSION AT MAXIMUM MATERIAL CONDITION.

| DIM | MILLIMETERS | | INCHES | |
|-----|-------------|-------|-----------|-------|
| | MIN | MAX | MIN | MAX |
| A | 9.80 | 10.00 | 0.386 | 0.393 |
| B | 3.80 | 4.00 | 0.150 | 0.157 |
| C | 1.35 | 1.75 | 0.054 | 0.068 |
| D | 0.35 | 0.49 | 0.014 | 0.019 |
| F | 0.40 | 1.25 | 0.016 | 0.049 |
| G | 1.27 BSC | | 0.050 BSC | |
| J | 0.19 | 0.25 | 0.008 | 0.009 |
| K | 0.10 | 0.25 | 0.004 | 0.009 |
| M | 0° | 7° | 0° | 7° |
| P | 5.80 | 6.20 | 0.229 | 0.244 |
| R | 0.25 | 0.50 | 0.010 | 0.019 |

SOLDERING FOOTPRINT

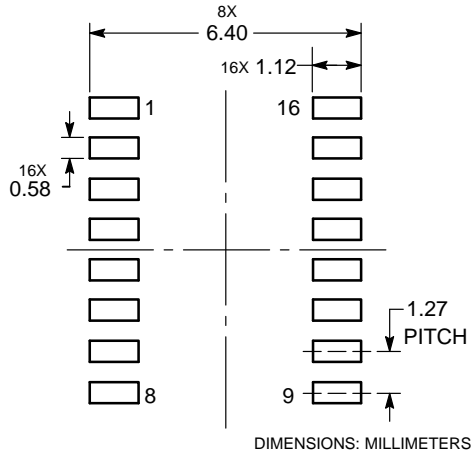

MC74VHC259

PACKAGE DIMENSIONS

TSSOP-16
CASE 948F
ISSUE B

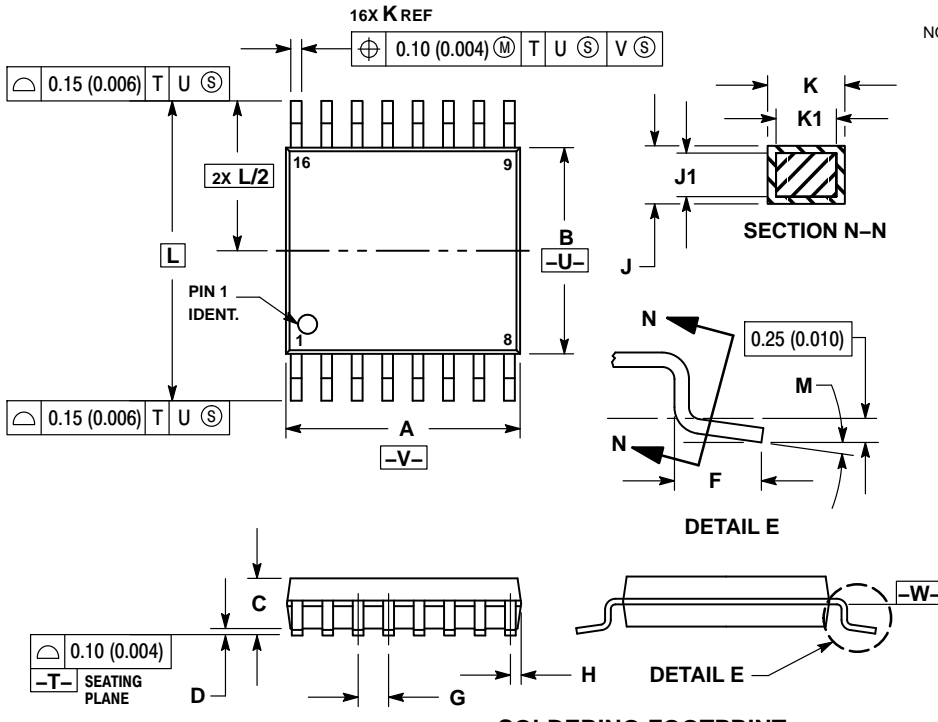

NOTES:

1. DIMENSIONING AND TOLERANCING PER ANSI Y14.5M, 1982.
2. CONTROLLING DIMENSION: MILLIMETER.
3. DIMENSION A DOES NOT INCLUDE MOLD FLASH. PROTRUSIONS OR GATE BURRS. MOLD FLASH OR GATE BURRS SHALL NOT EXCEED 0.15 (0.006) PER SIDE.
4. DIMENSION B DOES NOT INCLUDE INTERLEAD FLASH OR PROTRUSION. INTERLEAD FLASH OR PROTRUSION SHALL NOT EXCEED 0.25 (0.010) PER SIDE.
5. DIMENSION K DOES NOT INCLUDE DAMBAR PROTRUSION. ALLOWABLE DAMBAR PROTRUSION SHALL BE 0.08 (0.003) TOTAL IN EXCESS OF THE K DIMENSION AT MAXIMUM MATERIAL CONDITION.
6. TERMINAL NUMBERS ARE SHOWN FOR REFERENCE ONLY.
7. DIMENSION A AND B ARE TO BE DETERMINED AT DATUM PLANE -W-.

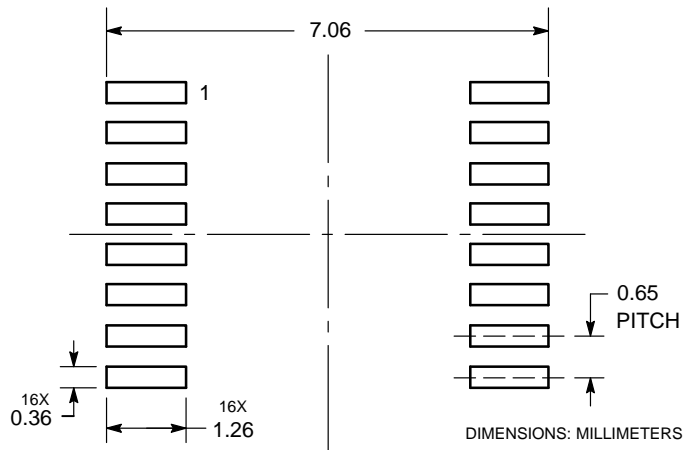

ON Semiconductor and the  are registered trademarks of Semiconductor Components Industries, LLC (SCILLC) or its subsidiaries in the United States and/or other countries. SCILLC owns the rights to a number of patents, trademarks, copyrights, trade secrets, and other intellectual property. A listing of SCILLC's product/patent coverage may be accessed at www.onsemi.com/site/pdf/Patent-Marking.pdf. SCILLC reserves the right to make changes without further notice to any products herein. SCILLC makes no warranty, representation or guarantee regarding the suitability of its products for any particular purpose, nor does SCILLC assume any liability arising out of the application or use of any product or circuit, and specifically disclaims any and all liability, including without limitation special, consequential or incidental damages. "Typical" parameters which may be provided in SCILLC data sheets and/or specifications can and do vary in different applications and actual performance may vary over time. All operating parameters, including "Typicals" must be validated for each customer application by customer's technical experts. SCILLC does not convey any license under its patent rights nor the rights of others. SCILLC products are not designed, intended, or authorized for use as components in systems intended for surgical implant into the body, or other applications intended to support or sustain life, or for any other application in which the failure of the SCILLC product could create a situation where personal injury or death may occur. Should Buyer purchase or use SCILLC products for any such unintended or unauthorized application, Buyer shall indemnify and hold SCILLC and its officers, employees, subsidiaries, affiliates, and distributors harmless against all claims, costs, damages, and expenses, and reasonable attorney fees arising out of, directly or indirectly, any claim of personal injury or death associated with such unintended or unauthorized use, even if such claim alleges that SCILLC was negligent regarding the design or manufacture of the part. SCILLC is an Equal Opportunity/Affirmative Action Employer. This literature is subject to all applicable copyright laws and is not for resale in any manner.

PUBLICATION ORDERING INFORMATION

LITERATURE FULFILLMENT:

Literature Distribution Center for ON Semiconductor
P.O. Box 5163, Denver, Colorado 80217 USA
Phone: 303-675-2175 or 800-344-3860 Toll Free USA/Canada
Fax: 303-675-2176 or 800-344-3867 Toll Free USA/Canada
Email: orderlit@onsemi.com

N. American Technical Support: 800-282-9855 Toll Free
USA/Canada
Europe, Middle East and Africa Technical Support:
Phone: 421 33 790 2910
Japan Customer Focus Center
Phone: 81-3-5817-1050

ON Semiconductor Website: www.onsemi.com

Order Literature: <http://www.onsemi.com/orderlit>

For additional information, please contact your local Sales Representative

X-ON Electronics

Largest Supplier of Electrical and Electronic Components

Click to view similar products for [Latches category](#):

Click to view products by [ON Semiconductor manufacturer](#):

Other Similar products are found below :

[M38510/75403BSA](#) [634674X](#) [634752C](#) [ML4875CS-5](#) [54FCT573ATDB](#) [401639B](#) [027063C](#) [029314R](#) [54FCT573CTLB](#) [NLV14043BDR2G](#)
[716165RB](#) [74F373DW](#) [74LVC373ADTR2G](#) [74LVC573ADTR2G](#) [NL17SG373DFT2G](#) [NLV14044BDG](#) [5962-8863901RA](#) [5962-88639012A](#)
[2.PM30.006-30](#) [MIC59P50YV](#) [NLV14042BDR2G](#) [4.401.001](#) [NLV14044BDR2G](#) [2.L18.001-21](#) [2.PM18.002-18](#) [2.PM18.006-18](#) [2.T18.001-](#)
[21](#) [2.T18.002-18](#) [2.T18.006-18](#) [CQ/AA-KEY](#) [CQ/A-M22X1,5-45-28](#) [CQ/A-M22X1,5-45-32](#) [M22-2-D5-2-21-01-P](#) [CY74FCT2373CTSOC](#)
[421283](#) [74ALVCH16260PAG](#) [74FCT373CTQG](#) [MM74HC373WM](#) [MM74HC573MTCX](#) [MM74HC573WM](#) [74LCX373MTC](#)
[74LVT16373MTDX](#) [74VHC373MX](#) [KLD5.001-02](#) [KLT9.001-02](#) [Z-0233-827-15](#) [74AHCT573D.112](#) [74FCT16373CTPVG8](#)
[74FCT573ATQG](#) [74LCX16373MTDX](#)