

Features

- 4-multiplier configuration
- Single PLL architecture
- Phase alignment
- Low jitter, high accuracy outputs
- Output enable pin
- 3.3 V operation
- 5 V tolerant input
- Internal loop filter
- 8-pin 150-mil small-outline integrated circuit (SOIC) package
- Commercial temperature

Functional Description

The CY2300 is a 4 output 3.3 V phase-aligned system clock designed to distribute high-speed clocks in PC, workstation, datacom, telecom, and other high-performance applications.

The part allows the user to obtain $1/2x$, $1x$, $\overline{1x}$ and $2x$ REF_{IN} output frequencies on respective output pins.

The part has an on-chip PLL which locks to an input clock presented on the REF_{IN} pin. The input-to-output skew is guaranteed to be less than ± 200 ps, and output-to-output skew is guaranteed to be less than 200 ps.

Multiple CY2300 devices can accept the same input clock and distribute it in a system. In this case, the skew between the outputs of two devices is guaranteed to be less than 400 ps.

The CY2300 is available in commercial temperature range.

Logic Block Diagram

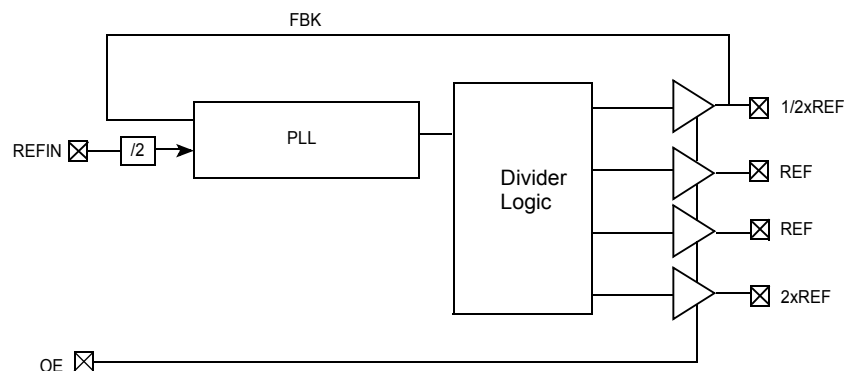

Contents

Pinouts	3	Document Conventions	9
Pin Definitions	3	Units of Measure	9
Maximum Ratings	4	Errata	10
Operating Conditions	4	Part Numbers Affected	10
Electrical Characteristics	4	CY2300 Errata Summary	10
Switching Characteristics	5	CY2300 Qualification Status of fixed silicon	10
Switching Waveforms	6	Document History Page	12
Test Circuits	7	Sales, Solutions, and Legal Information	13
Ordering Information	7	Worldwide Sales and Design Support	13
Ordering Code Definitions	7	Products	13
Package Drawing and Dimensions	8	PSoC® Solutions	13
Reference Documents	9	Cypress Developer Community	13
Acronyms	9	Technical Support	13

Pinouts

Figure 1. 8-pin SOIC pinout (Top View)

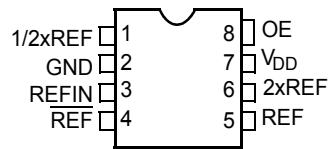

Pin Definitions

Pin	Signal ^[1]	Description
1	1/2xREF	Clock output, 1/2x reference
2	GND	Ground
3	REFIN	Input reference frequency, 5 V tolerant input
4	REF	Clock output reference
5	REF	Clock output reference
6	2xREF	Clock output, 2x reference
7	V _{DD}	3.3 V Supply
8	OE	Output enable (weak pull-up)

Note

1. Weak pull-down on all outputs.

Maximum Ratings

Supply voltage to ground potential-0.5 V to +7.0 V
 DC input voltage (except ref)-0.5 V to $V_{DD} + 0.5$ V
 DC input voltage REF-0.5 V to 7 V

Storage temperature -65 °C to +150 °C
 Junction temperature 150 °C
 Static discharge voltage
 (per MIL-STD-883, method 3015) > 2000 V

Operating Conditions

Parameter	Description	Min	Max	Unit
V_{DD}	Supply voltage	3.0	3.6	V
T_A	Operating temperature (ambient temperature)	0	70	°C
C_L	Load capacitance, 10 MHz < F_{OUT} < 133.33 MHz	-	18	pF
	Load capacitance, 133.33 MHz < F_{OUT} < 166.67 MHz	-	12	pF
C_{IN}	Input capacitance	-	7	pF
t_{PU}	Power-up time for all V_{DD} 's to reach minimum specified voltage (power ramps must be monotonic)	0.05	50	ms

Electrical Characteristics

Parameter	Description	Test Conditions	Min	Max	Unit
V_{IL}	Input LOW voltage		-	0.8	V
V_{IH}	Input HIGH voltage		2.0	-	V
I_{IL}	Input LOW current	$V_{IN} = 0$ V	-	100	µA
I_{IH}	Input HIGH current	$V_{IN} = V_{DD}$	-	50	µA
V_{OL}	Output LOW voltage ^[2]	$I_{OL} = 8$ mA	-	0.4	V
V_{OH}	Output HIGH voltage ^[2]	$I_{OH} = -8$ mA	2.4	-	V
I_{DD}	Supply current	Unloaded outputs, REFIN = 66 MHz	-	45	mA
		Unloaded outputs, REFIN = 33 MHz	-	32	mA
		Unloaded outputs, REFIN = 20 MHz	-	18	mA

Note

2. Parameter is guaranteed by design and characterization. It is not 100% tested in production.

Switching Characteristics

Parameter	Description	Test Conditions	Min	Typ	Max	Unit
1/t ₁	Output frequency	18-pF load	10	–	133.33	MHz
		12-pF load	–	–	166.67	MHz
	Duty cycle ^[3] = t ₂ ÷ t ₁	Measured at V _{DD} /2	40	50	60	%
t ₃	Rise time ^[3]	Measured between 0.8 V and 2.0 V	–	–	1.20	ns
t ₄	Fall time ^[3]	Measured between 0.8 V and 2.0 V	–	–	1.20	ns
t ₅	Output to output skew on rising edges ^[3]	All outputs equally loaded Measured at V _{DD} /2	–	–	200	ps
t ₆	Delay, REFIN rising edge to output rising edge ^[3]	Measured at V _{DD} /2 from REFIN to any output	–	–	±200	ps
t ₇	Device to device skew ^[3]	Measured at V _{DD} /2 on the 1/2xREF pin of devices (pin 1)	–	–	400	ps
t _J	Period jitter ^[3]	Measured at F _{out} = 133.33 MHz, loaded outputs, 18-pF load	–	–	±175	ps
t _{LOCK}	PLL lock time ^[3]	Stable power supply, valid clocks presented on REFIN	–	–	1.0	ms

Note

3. All parameters are specified with equally loaded outputs.

Switching Waveforms

Figure 2. Duty Cycle Timing

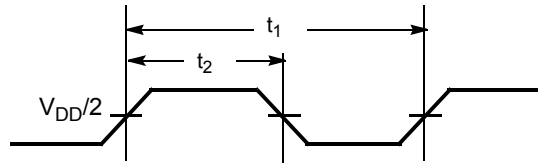

Figure 3. All Outputs Rise/Fall Time

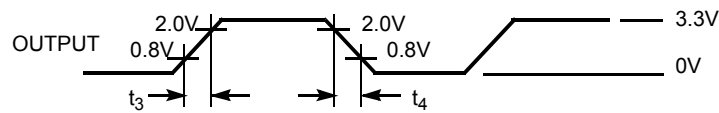

Figure 4. Output to Output Skew

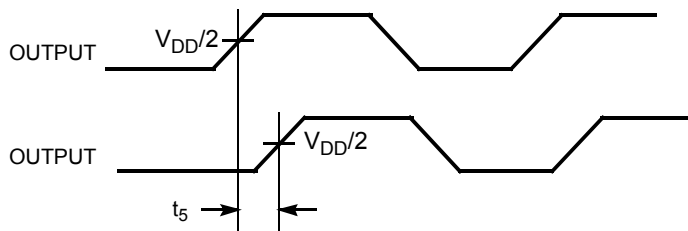

Figure 5. Input to Output Propagation Delay

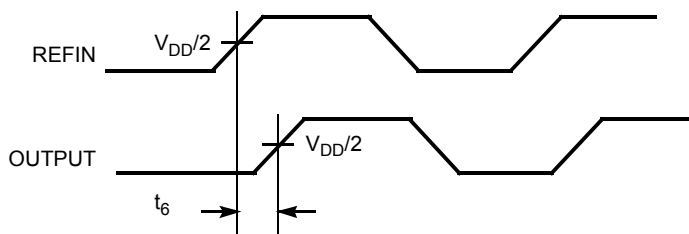
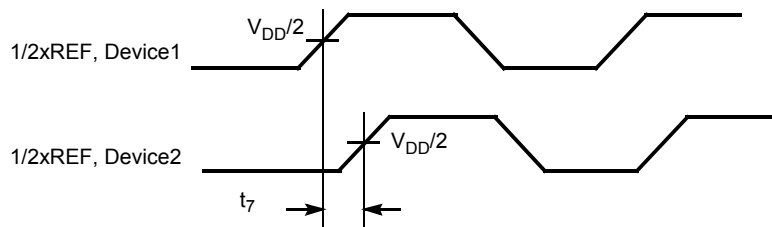
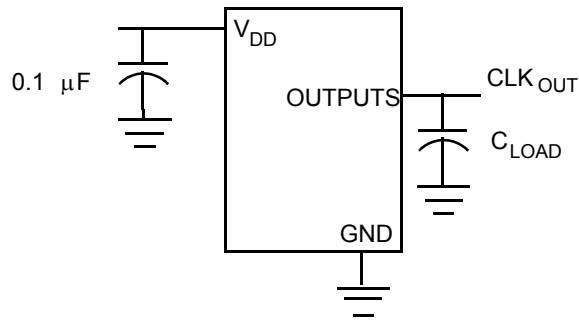

Figure 6. Device to Device Skew



Test Circuits

Figure 7. Test Circuit #1



Ordering Information

Ordering Code	Package Type	Operating Range
Pb-free		
CY2300SXC	8-pin SOIC	Commercial (0 °C to 70 °C)
CY2300SXCT	8-pin SOIC - Tape and Reel	Commercial (0 °C to 70 °C)

Ordering Code Definitions

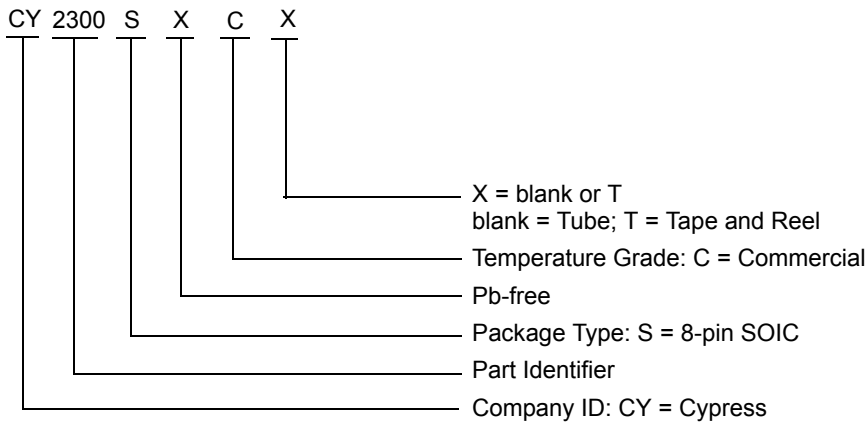

Package Drawing and Dimensions

Figure 8. 8-pin SOIC (150 Mils) Package Outline, 51-85066

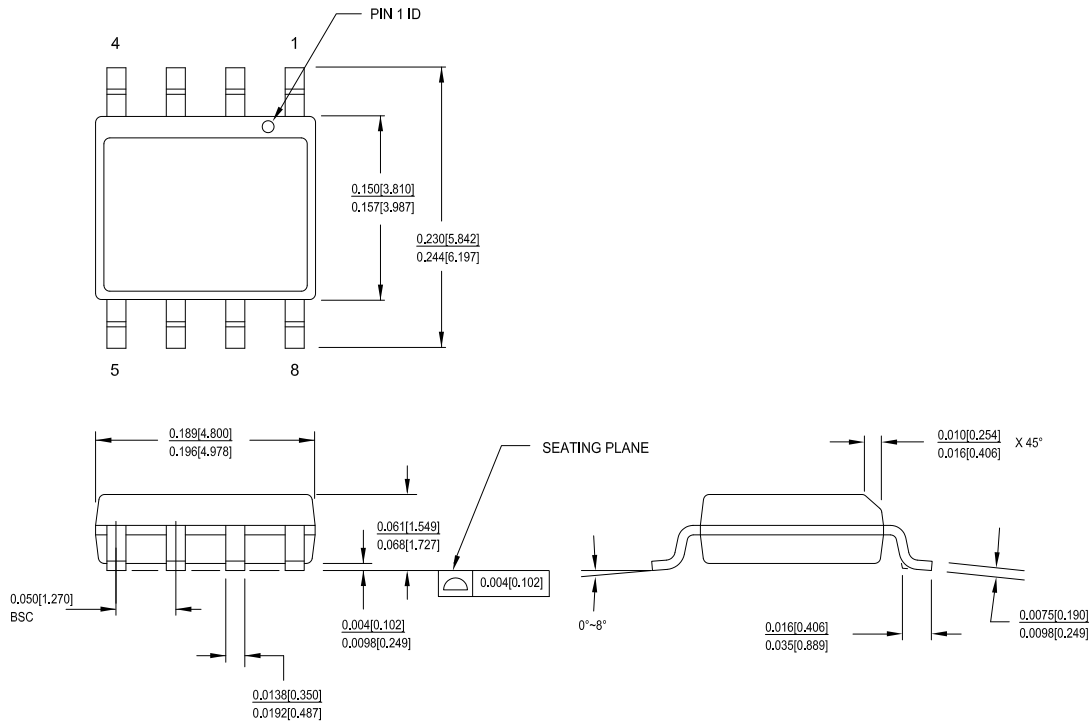

51-85066 *F

Reference Documents

Reference documents are available through your local Cypress sales representative. You can also direct your requests to tsbusdev@cypress.com.

Document Number	Document Title	Description
NA	NA	NA

Acronyms

Acronym	Description
FBK	Feedback
OE	Output Enable
PLL	Phase Locked Loop
REFIN	Reference Input

Document Conventions

Units of Measure

Symbol	Unit of Measure
°C	degree Celsius
Hz	hertz
kHz	kilohertz
MHz	megahertz
μA	microampere
μF	microfarad
μs	microsecond
μV	microvolt
mA	milliampere
mm	millimeter
ms	millisecond
mV	millivolt
ns	nanosecond
pA	picoampere
pF	picofarad
ps	picosecond
V	volt

Errata

This section describes the errors, workaround solution and silicon design fixes for Cypress zero delay clock buffers belonging to the families CY2300. Details include errata trigger conditions, scope of impact, available workaround and silicon revision applicability. Contact your local Cypress Sales Representative if you have questions.

Part Numbers Affected

Part Number	Device Characteristics
CY2300SXC	All Variants
CY2300SXCT	All Variants

CY2300 Errata Summary

Items	Part Number	Fix Status
Start up lock time issue [CY2300]	All	Silicon fixed. New silicon available from WW 10 of 2013

CY2300 Qualification Status of fixed silicon

Product Status: In production

Qualification report last updated on 11/27/2012

<http://www.cypress.com/?rID=72595>

1. Start up lock time issue

■ Problem Definition

Output of CY2300 fails to locks within 1 ms upon power up (as per datasheet spec).

■ Parameters Affected

PLL lock time (t_{LOCK})

■ Trigger Condition(S)

Start up

■ Scope of Impact

It can impact the performance of system and its throughput.

■ Workaround

Apply reference input (RefClk) before power up (VDD). If RefClk is applied after power up, noise gets coupled on the output and propagates back to the PLL causing it to take higher time to acquire lock. If reference input is present during power up, noise will not propagate to the PLL and device will start up normally without problems.

■ Fix Status

This issue is due to design marginality. Two minor design modifications have been made to address this problem.

- Addition of VCO bias detector block as shown in the following figure keeps comparator power down till VCO bias is present and thereby eliminating the propagation of noise to feedback.
- Bias generator enhancement for successful initialization.

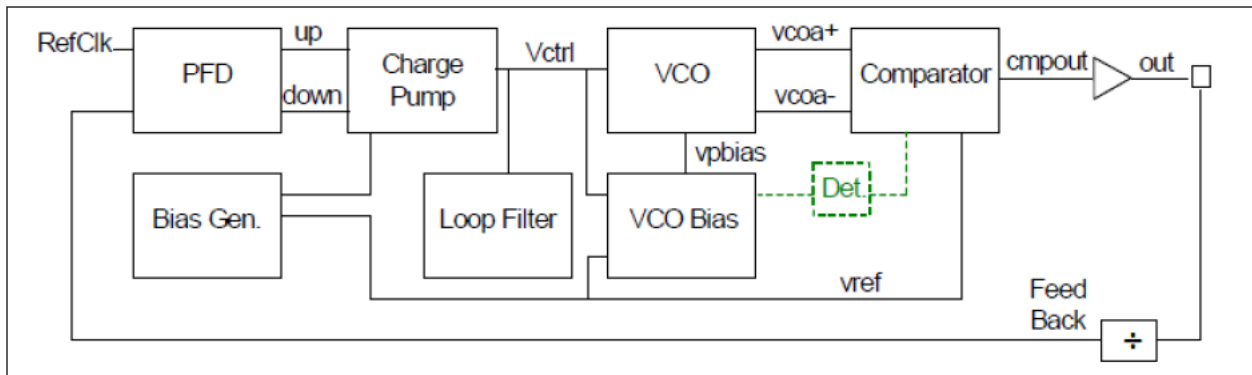

Document History Page

Document Title: CY2300, Phase-Aligned Clock Multiplier Document Number: 38-07252				
Rev.	ECN	Orig. of Change	Submission Date	Description of Change
**	110517	SZV	01/07/02	Change from Spec number: 38-01039 to 38-07252
*A	121854	RBI	12/14/02	Power up requirements added to Operating Conditions Information
*B	246829	RGL	08/02/04	Added Lead Free Devices
*C	2568533	AESA	09/23/08	Updated template. Removed Selector Guide. Removed Operating Conditions for CY2300SI Industrial Temperature Devices. Removed Electrical Characteristics for CY2300SI Industrial Temperature Devices. Removed Switching Characteristics for CY2300SI Industrial Temperature Devices. Removed part number CY2300SC, CY2300SC, CY2300SI, CY2300SI, CY2300SXI and CY2300SXIT.
*D	3026183	BASH	09/01/2010	Removed "Benefits" from page 1. Added lower limit of 10MHz for 18pF load capacitance in Operating Conditions on page 3. Added Ordering Code Definitions . Added Reference Documents, Acronyms and Units of Measure .
*E	4126294	CINM	11/25/2013	Updated Package Drawing and Dimensions : spec 51-85066 – Changed revision from *D to *F. Added Errata . Updated in new template. Completing Sunset Review.
*F	4325140	CINM	03/28/2014	Updated Errata .

Sales, Solutions, and Legal Information

Worldwide Sales and Design Support

Cypress maintains a worldwide network of offices, solution centers, manufacturer's representatives, and distributors. To find the office closest to you, visit us at [Cypress Locations](#).

Products

Automotive	cypress.com/go/automotive
Clocks & Buffers	cypress.com/go/clocks
Interface	cypress.com/go/interface
Lighting & Power Control	cypress.com/go/powerpsoc cypress.com/go/plc
Memory	cypress.com/go/memory
PSoC	cypress.com/go/psoc
Touch Sensing	cypress.com/go/touch
USB Controllers	cypress.com/go/USB
Wireless/RF	cypress.com/go/wireless

PSoC[®] Solutions

[psoc.cypress.com/solutions](#)
[PSoC 1](#) | [PSoC 3](#) | [PSoC 4](#) | [PSoC 5LP](#)

Cypress Developer Community

[Community](#) | [Forums](#) | [Blogs](#) | [Video](#) | [Training](#)

Technical Support

[cypress.com/go/support](#)

© Cypress Semiconductor Corporation, 2002-2014. The information contained herein is subject to change without notice. Cypress Semiconductor Corporation assumes no responsibility for the use of any circuitry other than circuitry embodied in a Cypress product. Nor does it convey or imply any license under patent or other rights. Cypress products are not warranted nor intended to be used for medical, life support, life saving, critical control or safety applications, unless pursuant to an express written agreement with Cypress. Furthermore, Cypress does not authorize its products for use as critical components in life-support systems where a malfunction or failure may reasonably be expected to result in significant injury to the user. The inclusion of Cypress products in life-support systems application implies that the manufacturer assumes all risk of such use and in doing so indemnifies Cypress against all charges.

Any Source Code (software and/or firmware) is owned by Cypress Semiconductor Corporation (Cypress) and is protected by and subject to worldwide patent protection (United States and foreign), United States copyright laws and international treaty provisions. Cypress hereby grants to licensee a personal, non-exclusive, non-transferable license to copy, use, modify, create derivative works of, and compile the Cypress Source Code and derivative works for the sole purpose of creating custom software and or firmware in support of licensee product to be used only in conjunction with a Cypress integrated circuit as specified in the applicable agreement. Any reproduction, modification, translation, compilation, or representation of this Source Code except as specified above is prohibited without the express written permission of Cypress.

Disclaimer: CYPRESS MAKES NO WARRANTY OF ANY KIND, EXPRESS OR IMPLIED, WITH REGARD TO THIS MATERIAL, INCLUDING, BUT NOT LIMITED TO, THE IMPLIED WARRANTIES OF MERCHANTABILITY AND FITNESS FOR A PARTICULAR PURPOSE. Cypress reserves the right to make changes without further notice to the materials described herein. Cypress does not assume any liability arising out of the application or use of any product or circuit described herein. Cypress does not authorize its products for use as critical components in life-support systems where a malfunction or failure may reasonably be expected to result in significant injury to the user. The inclusion of Cypress' product in a life-support systems application implies that the manufacturer assumes all risk of such use and in doing so indemnifies Cypress against all charges.

Use may be limited by and subject to the applicable Cypress software license agreement.

X-ON Electronics

Largest Supplier of Electrical and Electronic Components

Click to view similar products for [Phase Locked Loops - PLL category](#):

Click to view products by [Cypress manufacturer](#):

Other Similar products are found below :

[ADF4152HVBCPZ-RL7](#) [HMC440QS16GTR](#) [LC72135MA-Q-AE](#) [SL28EB725ALI](#) [HMC698LP5ETR](#) [HMC699LP5ETR](#) [HMC700LP4TR](#)
[LC7185-8750-E](#) [MB15E07SLPFV1-G-BND-6E1](#) [XRT8001ID-F](#) [ATA8404C-6DQY-66](#) [PI6C2409-1HWE](#) [ATA8405C-6DQY-66](#)
[MAX2870ETJ+T](#) [PI6C2409-1HWEX](#) [CYW170-01SXC](#) [HMC764LP6CETR](#) [HMC767LP6CETR](#) [HMC820LP6CETR](#) [HMC828LP6CETR](#)
[HMC834LP6GETR](#) [ispPAC-CLK5410D-01SN64C](#) [SI4113-D-GM](#) [82V3002APVG](#) [PI6C2405A-1WE](#) [CY22050KFI](#) [CY25200KFZXC](#)
[CY29973AXI](#) [CY2XP22ZXI](#) [W232ZXC-10](#) [CDCE937QPWRQ1](#) [CY2077FZXI](#) [CY2546FC](#) [CY2XF23FLXIT](#) [CYISM560BSXC](#)
[LMX2430TMX/NOPB](#) [HMC837LP6CETR](#) [HMC831LP6CETR](#) [ATA8404C-6DQY-66](#) [ADF4155BCPZ-RL7](#) [MB15E07SRPFT-G-BNDE1](#)
[NB3N5573DTG](#) [MAX2660EUT+T](#) [SI4123-D-GT](#) [SI4112-D-GM](#) [NB4N441MNR2G](#) [9DB433AGILFT](#) [ADF4116BRUZ-REEL7](#)
[ADF4153ABCPZ](#) [MAX2682EUT+T](#)