

# Spread Spectrum Clock Generator

## Features

- 4 to 32 MHz Input Frequency Range
- 4 to 128 MHz Output Frequency Range
- Accepts Clock, Crystal, and Resonator Inputs
- 1x, 2x, and 4x frequency multiplication:
  - CY25811: 1x; CY25812: 2x; CY25814: 4x
- Center and Down Spread Modulation
- Low Power Dissipation:
  - 3.3V = 52 mW - typ at 6 MHz
  - 3.3V = 60 mW - typ at 12 MHz
  - 3.3V = 72 mW - typ at 24 MHz
- Low Cycle to Cycle Jitter:
  - 8 MHz = 480 ps-max
  - 16 MHz = 400 ps-max
  - 32 MHz = 450 ps-max
- Available in 8-pin SOIC and TSSOP Packages
- Commercial and Industrial Temperature Ranges

## Applications

- Printers and MFPs
- LCD panels
- Digital copiers
- PDAs
- CD-ROM, VCD, and DVD
- Networking, LAN, and WAN
- Scanners
- Modems
- Embedded digital systems

## Benefits

- Peak EMI reduction by 8 to 16 dB
- Fast time to market
- Cost reduction
- For a complete list of related documentation, click [here](#).

## Logic Block Diagram

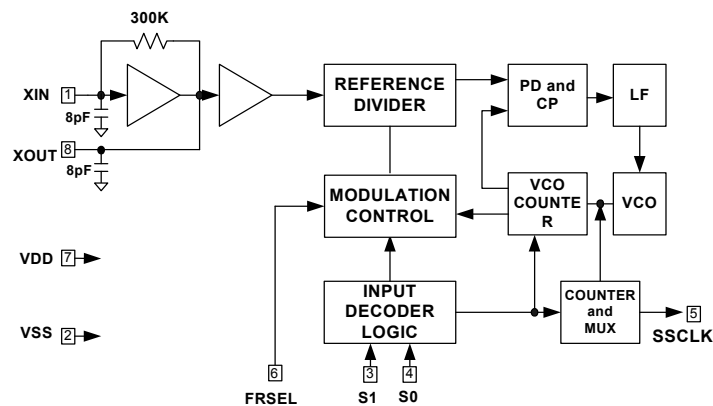

## Contents

<b>Pin Configuration</b> .....	<b>3</b>	<b>Ordering Information</b> .....	<b>12</b>
<b>Pin Definitions</b> .....	<b>3</b>	Ordering Code Definitions .....	12
<b>Functional Overview</b> .....	<b>3</b>	<b>Package Drawing and Dimensions</b> .....	<b>13</b>
Input Frequency Range and Selection .....	3	<b>Acronyms</b> .....	<b>15</b>
Spread Percentage Selection .....	4	<b>Document Conventions</b> .....	<b>15</b>
Input and Output Frequency Selection .....	5	Units of Measure .....	15
<b>Absolute Maximum Conditions</b> .....	<b>6</b>	<b>Document History Page</b> .....	<b>16</b>
<b>DC Electrical Specifications</b> .....	<b>6</b>	<b>Sales, Solutions, and Legal Information</b> .....	<b>17</b>
<b>AC Electrical Specifications</b> .....	<b>7</b>	Worldwide Sales and Design Support .....	17
<b>DC Electrical Specifications</b> .....	<b>7</b>	Products .....	17
<b>AC Electrical Specifications</b> .....	<b>8</b>	PSoC® Solutions .....	17
<b>Characteristic Curves</b> .....	<b>9</b>	Cypress Developer Community .....	17
<b>SSCG Profiles</b> .....	<b>10</b>	Technical Support .....	17
<b>Application Schematic</b> .....	<b>11</b>		

## Pin Configuration

Figure 1. CY25811/12/14 8-pin SOIC/TSSOP

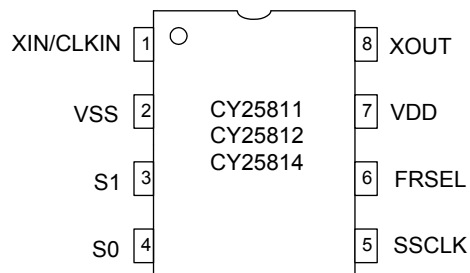

## Pin Definitions

Pin No.	Name	Type	Description
1	XIN/CLK		<b>Crystal, Ceramic Resonator or Clock Input Pin.</b>
2	VSS		<b>Power Supply Ground.</b>
3	S1		<b>Digital Spread% Control Pin.</b> 3-Level input (H-M-L). Default = M.
4	S0		<b>Digital Spread% Control Pin.</b> 3-Level input (H-M-L). Default = M.
5	SSCLK		<b>Spread Spectrum Output Clock.</b>
6	FRSEL		<b>Input Frequency Range Selection Digital Control Input.</b> 3-Level input (H-M-L). Default = M.
7	VDD		<b>Positive Power Supply.</b>
8	XOUT		<b>Crystal or Ceramic Resonator Output Pin.</b>

## Functional Overview

The CY25811/12/14 products are Spread Spectrum Clock Generator (SSCG) ICs used for the purpose of reducing electromagnetic interference (EMI) found in today's high speed digital electronic systems.

The devices use a Cypress proprietary phase-locked loop (PLL) and Spread Spectrum Clock (SSC) technology to synthesize and modulate the frequency of the input clock. By frequency modulating the clock, the measured EMI at the fundamental and harmonic frequencies is greatly reduced.

This reduction in radiated energy significantly reduces the cost of complying with regulatory agency requirements and improves time to market without degrading system performance.

The input frequency range is 4 to 32 MHz and accepts clock, crystal and ceramic resonator inputs. The output clock can be selected to produce 1x, 2x, or 4x multiplication of the input frequency with Spread Spectrum Frequency Modulation.

The use of 2x or 4x frequency multiplication eliminates the need for higher order crystals and enables you to generate up to 128 MHz Spread Spectrum Clock (SSC) by using only first order crystals. This reduces the cost while improving the system clock accuracy, performance, and complexity.

Select the Center Spread or Down Spread frequency modulation based on four discrete values of Spread % for each Spread mode with the option of a Non Spread mode for system test and verification purposes.

The CY25811/12/14 products are available in an 8-pin SOIC (150 mils) package with a commercial operating temperature range of 0 °C to 70 °C and industrial temperature range of -40 °C to 85 °C. Refer to [CY25568](#) for multiple clock output options such as modulated and unmodulated clock outputs or power down function.

### Input Frequency Range and Selection

The CY25811/12/14 input frequency range is 4 to 32 MHz. This range is divided into three segments and controlled by a 3-level FRSEL pin as given in [Table 1](#).

Table 1. Input Frequency Selection

FRSEL	Input Frequency Range
0	4.0 to 8.0 MHz
1	8.0 to 16.0 MHz
M	16.0 to 32.0 MHz

**Spread Percentage Selection**

The CY25811/12/14 SSCG products provide Center Spread, Down Spread, and No Spread functions. The amount of Spread percentage is selected using 3-level. S0 and S1 digital inputs and Spread percent values are given in Table 2.

**Table 2. Spread Percent Selection**

XIN (MHz)	FRSEL	S1 = 0 S0 = 0	S1 = 0 S0 = M	S1 = 0 S0 = 1	S1 = M S0 = 0	S1 = 1 S0 = 1	S1 = 1 S0 = 0	S1 = M S0 = 1	S1 = 1 S0 = M	S1 = M S0 = M
		Center (%)	Center (%)	Center (%)	Center (%)	Down (%)	Down (%)	Down (%)	Down (%)	No Spread
4-5	0	±1.4	± 1.2	± 0.6	± 0.5	-3.0	-2.2	-1.9	-0.7	0
5-6	0	±1.3	± 1.1	± 0.5	± 0.4	-2.7	-1.9	-1.7	-0.6	0
6-7	0	±1.2	± 0.9	± 0.5	± 0.4	-2.5	-1.8	-1.5	-0.6	0
7-8	0	±1.1	± 0.9	± 0.4	± 0.3	-2.3	-1.7	-1.4	-0.5	0
8-10	1	±1.4	±1.2	± 0.6	± 0.5	-3.0	-2.2	-1.9	-0.7	0
10-12	1	±1.3	±1.1	± 0.5	± 0.4	-2.7	-1.9	-1.7	-0.6	0
12-14	1	±1.2	± 0.9	± 0.5	± 0.4	-2.5	-1.8	-1.5	-0.6	0
14-16	1	±1.1	± 0.9	± 0.4	± 0.3	-2.3	-1.7	-1.4	-0.5	0
16-20	M	±1.4	±1.2	± 0.6	± 0.5	-3.0	-2.2	-1.9	-0.7	0
20-24	M	±1.3	±1.1	± 0.5	± 0.4	-2.7	-1.9	-1.7	-0.6	0
24-28	M	±1.2	± 0.9	± 0.5	± 0.4	-2.5	-1.8	-1.5	-0.6	0
28-32	M	±1.1	± 0.9	± 0.4	± 0.3	-2.3	-1.7	-1.4	-0.5	0

**3-Level Digital Inputs**

S0, S1, and FRSEL digital inputs are designed to sense three different logic levels designated as High “1”, Low “0”, and Middle “M”. With this 3-Level digital input logic, the 3-Level Logic detects nine different logic states.

S0, S1, and FRSEL pins include an on chip 20K (10K and 10K) resistor divider. No external application resistors are needed to implement the 3-level logic levels as shown here:

Logic Level “0”: 3-Level logic pin connected to GND.

Logic Level “M”: 3-Level logic pin left floating (no connection).

Logic Level “1”: 3-Level logic pin connected to V<sub>DD</sub>.

Figure 2 illustrates how to implement 3-Level Logic.

**Figure 2. 3-Level Logic**

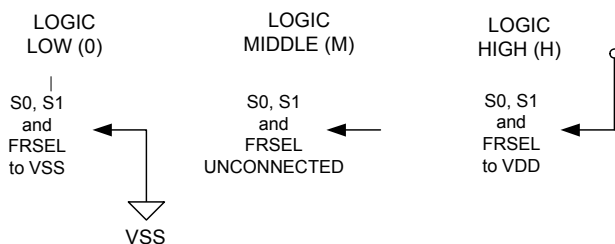

**Modulation Rate**

SSCGs use frequency modulation (FM) to distribute energy over a specific band of frequencies. The maximum frequency of the clock (f<sub>max</sub>) and minimum frequency of the clock (f<sub>min</sub>) determine this band of frequencies. The time required to transition from f<sub>min</sub> to f<sub>max</sub> and back to f<sub>min</sub> is the period of the Modulation Rate. The Modulation Rate of SSCG clocks are generally referred to in terms of frequency, or:

$$f_{mod} = 1/T_{mod}$$

The input clock frequency, f<sub>in</sub>, and the internal divider determine the Modulation Rate.

In CY25811/12/14 devices, the (Spread Spectrum) modulation rate, f<sub>mod</sub>, is given by the following formula:

$$f_{mod} = f_{in}/DR$$

Here f<sub>mod</sub> is the Modulation Rate, f<sub>in</sub> is the Input Frequency, and DR is the Divider Ratio as given in Table 3. Note that Input Frequency Range is set by FRSEL.

**Table 3. Modulation Rate Divider Ratios**

FRSEL	Input Frequency Range (MHz)	Divider Ratio (DR)
0	4 to 8	128
1	8 to 16	256
M	16 to 32	512

**Input and Output Frequency Selection**

The relationship between input frequency and output frequency in device selection and FRSEL setting is given in [Table 4](#). As shown, the input frequency range is selected by FRSEL and is the same for CY25811, CY25812, and CY25814. The selection of CY25811 (1x), CY25812 (2x), or CY25814 (4x) determines the frequency multiplication at the output (SSCLK, Pin 5) with respect to input frequency (XIN, Pin-1).

**Table 4. Input and Output Frequency Selection**

Input Frequency Range (MHz)	FRSEL	Product	Multiplication	Output Frequency Range (MHz)
4 to 8	0	CY25811	1x	4 to 8
8 to 16	1	CY25811	1x	8 to 16
16 to 32	M	CY25811	1x	16 to 32
4 to 8	0	CY25812	2x	8 to 16
8 to 16	1	CY25812	2x	16 to 32
16 to 32	M	CY25812	2x	32 to 64
4 to 8	0	CY25814	4x	16 to 32
8 to 16	1	CY25814	4x	32 to 64
16 to 32	M	CY25814	4x	64 to 128

## Absolute Maximum Conditions

Both Commercial and Industrial Grades

Parameter <sup>[1, 2]</sup>	Description	Condition	Min	Max	Unit
V <sub>DD</sub>	Supply Voltage		-0.5	4.6	V
V <sub>IN</sub>	Input Voltage	Relative to V <sub>SS</sub>	-0.5	V <sub>DD</sub> + 0.5	VDC
T <sub>S</sub>	Temperature, Storage	Non Functional	-65	150	°C
T <sub>A1</sub>	Temperature, Operating Ambient	Functional, C-Grade	0	70	°C
T <sub>A2</sub>	Temperature, Operating Ambient	Functional, I-Grade	-40	85	°C
T <sub>J</sub>	Temperature, Junction	Functional	-	150	°C
ESD <sub>HBM</sub>	ESD Protection (Human Body Model)	MIL-STD-883, Method 3015	2000	-	V
UL-94	Flammability Rating	at 1/8 in.	V-0		
MSL	Moisture Sensitivity Level		3		

## DC Electrical Specifications

Commercial Grade

Parameter	Description	Condition	Min	Max	Unit
V <sub>DD</sub>	3.3 V Operating Voltage	3.3 V ± 10%	2.97	3.63	V
V <sub>IL</sub>	Input Low Voltage	S0, S1 and FRSEL Inputs	0	0.15 × V <sub>DD</sub>	V
V <sub>IM</sub>	Input Middle Voltage	S0, S1 and FRSEL Inputs	0.40 × V <sub>DD</sub>	0.60 × V <sub>DD</sub>	V
V <sub>IH</sub>	Input High Voltage	S0, S1 and FRSEL Inputs	0.85 × V <sub>DD</sub>	V <sub>DD</sub>	V
V <sub>OL1</sub>	Output Low Voltage	I <sub>OL</sub> = 4 mA, SSCLK Output	-	0.4	V
V <sub>OL2</sub>	Output Low Voltage	I <sub>OL</sub> = 10 mA, SSCLK Output	-	1.2	V
V <sub>OH1</sub>	Output High Voltage	I <sub>OH</sub> = 4 mA, SSCLK Output	2.4	-	V
V <sub>OH2</sub>	Output High Voltage	I <sub>OH</sub> = 6 mA, SSCLK Output	2.0	-	V
C <sub>IN1</sub>	Input Pin Capacitance	XIN (Pin 1) and XOUT (Pin 8)	3.5	9.0	pF
C <sub>IN2</sub>	Input Pin Capacitance	All Digital Inputs	2.8	6.0	pF
C <sub>L</sub>	Output Load Capacitor	SSCLK Output	-	15	pF
I <sub>DD1</sub>	Dynamic Supply Current	F <sub>in</sub> = 12 MHz, no load	-	28	mA
I <sub>DD2</sub>	Dynamic Supply Current	F <sub>in</sub> = 24 MHz, no load	-	33	mA
I <sub>DD3</sub>	Dynamic Supply Current	F <sub>in</sub> = 32 MHz, no load	-	40	mA

### Notes

1. Operation at any Absolute Maximum Rating is not implied.
2. Single Power Supply: The voltage on any input or I/O pin cannot exceed the power pin during power up.

## AC Electrical Specifications

Commercial Grade

Parameter	Description	Condition	Min	Max	Unit
F <sub>IN</sub>	Input Frequency Range	Clock, Crystal, or Ceramic Resonator Input	4	32	MHz
T <sub>R1</sub>	Clock Rise Time	SSCLK, CY25811 and CY25812	2.0	5.0	ns
T <sub>F1</sub>	Clock Fall Time	SSCLK, CY25811 and CY25812	1.6	4.4	ns
T <sub>R2</sub>	Clock Rise Time	SSCLK, only CY25814 when FRSEL = M	1.0	2.2	ns
T <sub>F2</sub>	Clock Fall Time	SSCLK, only CY25814 when FRSEL = M	0.8	2.2	ns
T <sub>DCIN</sub>	Input Clock Duty Cycle	XIN	40	60	%
T <sub>DCOUT</sub>	Output Clock Duty Cycle	SSCLK	40	60	%
T <sub>CCJ1</sub>	Cycle to Cycle Jitter, Spread on	F <sub>in</sub> = 4 MHz, F <sub>out</sub> = 4 MHz, CY25811	–	800	ps
T <sub>CCJ2</sub>	Cycle to Cycle Jitter, Spread on	F <sub>in</sub> = 8 MHz, F <sub>out</sub> = 8 MHz, CY25811	–	480	ps
T <sub>CCJ3</sub>	Cycle to Cycle Jitter, Spread on	F <sub>in</sub> = 8 MHz, F <sub>out</sub> = 16 MHz, CY25812	–	400	ps
T <sub>CCJ4</sub>	Cycle to Cycle Jitter, Spread on	F <sub>in</sub> = 16 MHz, F <sub>out</sub> = 32 MHz, CY25812	–	450	ps
T <sub>CCJ5</sub>	Cycle to Cycle Jitter, Spread on	F <sub>in</sub> = 16 MHz, F <sub>out</sub> = 64 MHz, CY25814	–	550	ps
T <sub>CCJ6</sub>	Cycle to Cycle Jitter, Spread on	F <sub>in</sub> = 32 MHz, F <sub>out</sub> = 128 MHz, CY25814	–	380	ps
T <sub>SU</sub>	PLL Lock Time	From V <sub>DD</sub> = 3.0 V to valid SSCLK	–	3	ms

## DC Electrical Specifications

Industrial Grade

Parameter	Description	Condition	Min	Max	Unit
V <sub>DD</sub>	3.3 V Operating Voltage	3.3 V ± 5%	3.135	3.465	V
V <sub>IL</sub>	Input Low Voltage	S0, S1 and FRSEL Inputs	0	0.13 × V <sub>DD</sub>	V
V <sub>IM</sub>	Input Middle Voltage	S0, S1 and FRSEL Inputs	0.40 × V <sub>DD</sub>	0.60 × V <sub>DD</sub>	V
V <sub>IH</sub>	Input High Voltage	S0, S1 and FRSEL Inputs	0.85 × V <sub>DD</sub>	V <sub>DD</sub>	V
V <sub>OL1</sub>	Output Low Voltage	I <sub>OL</sub> = 4 mA, SSCLK Output	–	0.4	V
V <sub>OL2</sub>	Output Low Voltage	I <sub>OL</sub> = 10 mA, SSCLK Output	–	1.2	V
V <sub>OH1</sub>	Output High Voltage	I <sub>OH</sub> = 4 mA, SSCLK Output	2.4	–	V
V <sub>OH2</sub>	Output High Voltage	I <sub>OH</sub> = 6 mA, SSCLK Output	2.0	–	V
C <sub>IN1</sub>	Input Pin Capacitance	XIN (Pin 1) and XOUT (Pin 8)	3.5	9.0	pF
C <sub>IN2</sub>	Input Pin Capacitance	All Digital Inputs	2.8	6.0	pF
C <sub>L</sub>	Output Load Capacitor	SSCLK Output	–	15	pF
I <sub>DD1</sub>	Dynamic Supply Current	F <sub>in</sub> = 12 MHz, no load	–	28	mA
I <sub>DD2</sub>	Dynamic Supply Current	F <sub>in</sub> = 24 MHz, no load	–	33	mA
I <sub>DD3</sub>	Dynamic Supply Current	F <sub>in</sub> = 32 MHz, no load	–	41	mA

## AC Electrical Specifications

Industrial Grade

Parameter	Description	Condition	Min	Max	Unit
F <sub>IN</sub>	Input Frequency Range	Clock, Crystal or Ceramic Resonator Input	4	32	MHz
T <sub>R1</sub>	Clock Rise Time	SSCLK, CY25811, and CY25812	2.0	5.0	ns
T <sub>F1</sub>	Clock Fall Time	SSCLK, CY25811, and CY25812	1.6	4.4	ns
T <sub>R2</sub>	Clock Rise Time	SSCLK, only CY25814 when FRSEL = M	1.0	2.2	ns
T <sub>F2</sub>	Clock Fall Time	SSCLK, only CY25814 when FRSEL = M	0.8	2.2	ns
T <sub>DCIN</sub>	Input Clock Duty Cycle	XIN	40	60	%
T <sub>DCOUT</sub>	Output Clock Duty Cycle	SSCLK	40	60	%
T <sub>CCJ1</sub>	Cycle to Cycle Jitter, Spread on	Fin = 6 MHz, CY25811/12/14	–	650	ps
T <sub>CCJ2</sub>	Cycle to Cycle Jitter, Spread on	Fin = 12 MHz, CY25811/12/14	–	630	ps
T <sub>CCJ3</sub>	Cycle to Cycle Jitter, Spread on	Fin = 24 MHz, CY25811/12/14	–	520	ps
T <sub>SU</sub>	PLL Lock Time	From V <sub>DD</sub> = 3.0 V to valid SSCLK	–	4	ms



### Characteristic Curves

The following curves demonstrate the characteristic behavior of CY25811/12/14 when tested over a number of environmental and application specific parameters. These are typical performance curves and are not meant to replace any parameter specified in DC and AC Specification tables.

Figure 3. Characteristic Curves

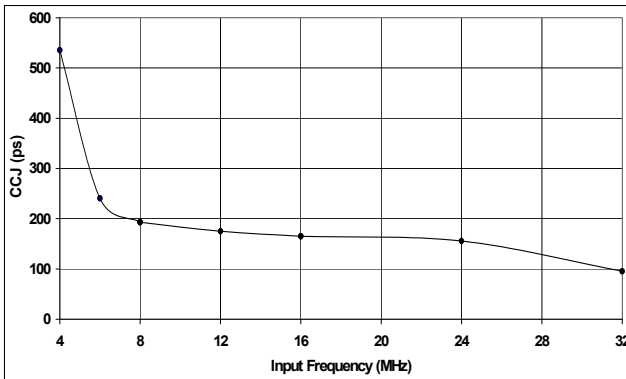

Jitter vs. Input Frequency (No Load)

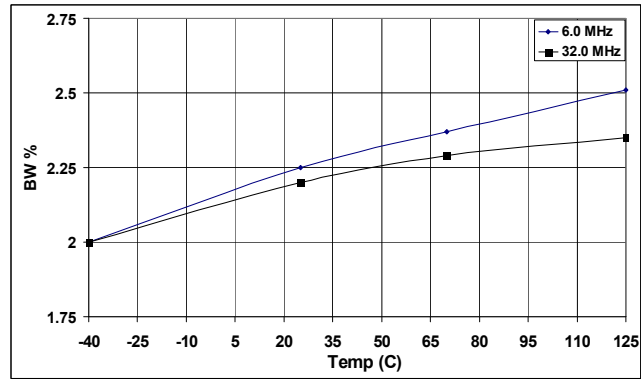

Bandwidth % vs. Temperature

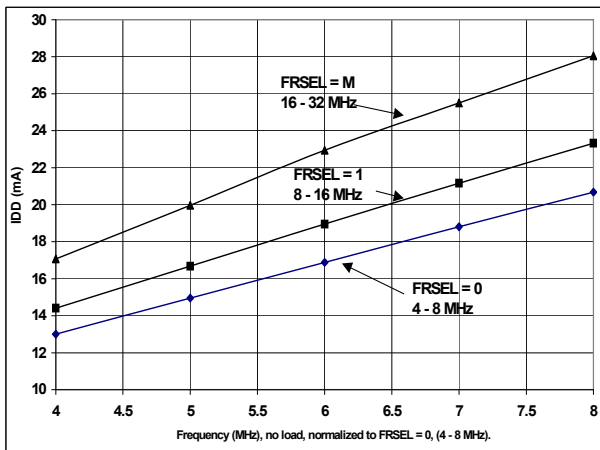

IDD vs. Frequency (FRSEL = 0, 1, M)

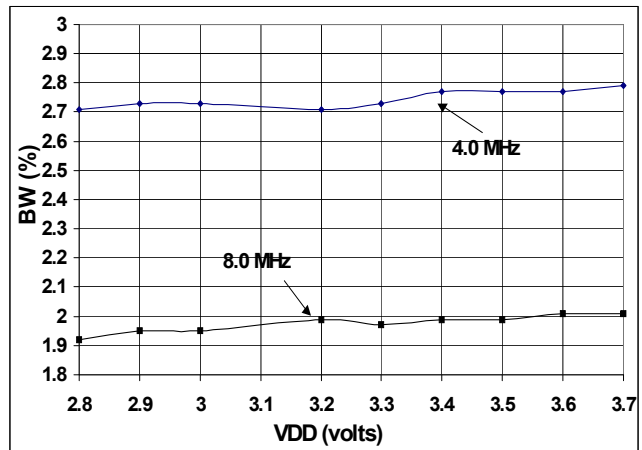

Bandwidth % vs. VDD

### SSCG Profiles

CY25811/12/14 SSCG products use a non-linear “optimized” frequency profile as shown in Figure 4. The use of Cypress proprietary “optimized” frequency profile maintains flat energy distribution over the fundamental and higher order harmonics. This results in additional EMI reduction in electronic systems.

Figure 4. Spread Spectrum Profiles (Frequency versus Time)

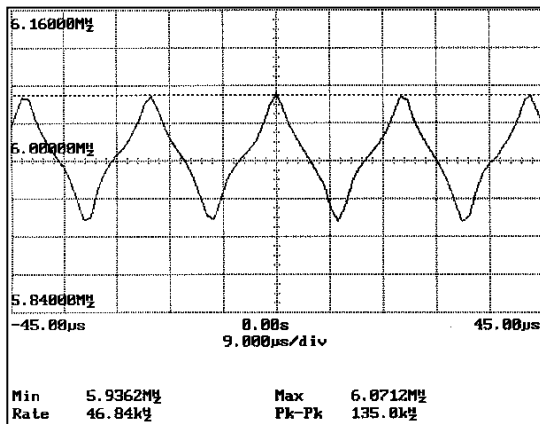

Xin = 6.0 MHz                      SSCLK1 = 6.0 MHz  
 S1, S0 = 0  
 FRSEL = 0                              P/N = CY25811

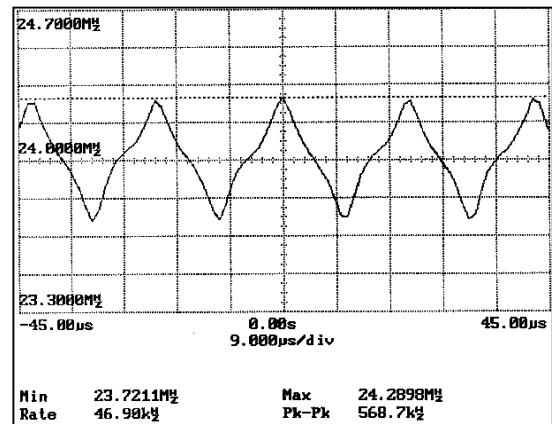

Xin = 24.0 MHz                      SSCLK1 = 24.0 MHz  
 S1, S0 = 0  
 FRSEL = M                              P/N = CY25811

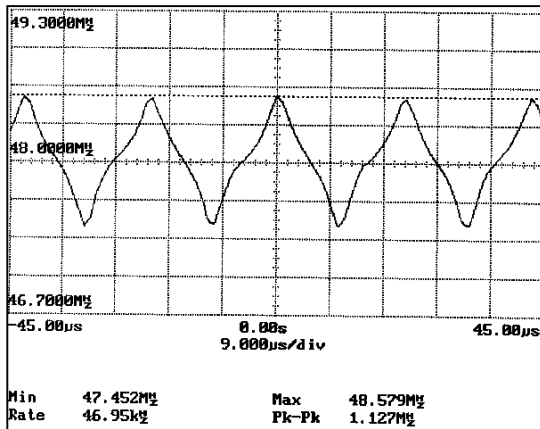

Xin = 12.0 MHz                      SSCLK1 = 48.0 MHz  
 S1, S0 = 0  
 FRSEL = 1                              P/N = CY25814

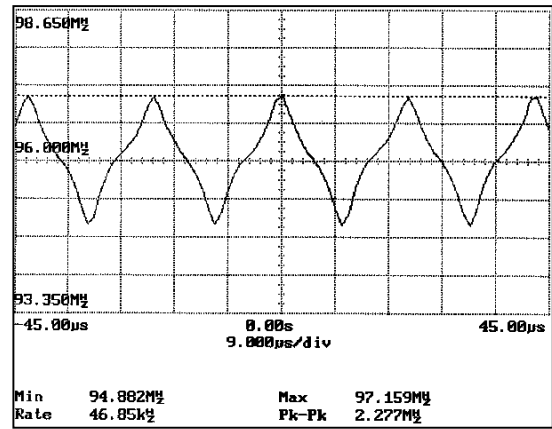

Xin = 24.0 MHz                      SSCLK1 = 96.0 MHz  
 S1, S0 = 0  
 FRSEL = M                              P/N = CY25814

**Application Schematic**

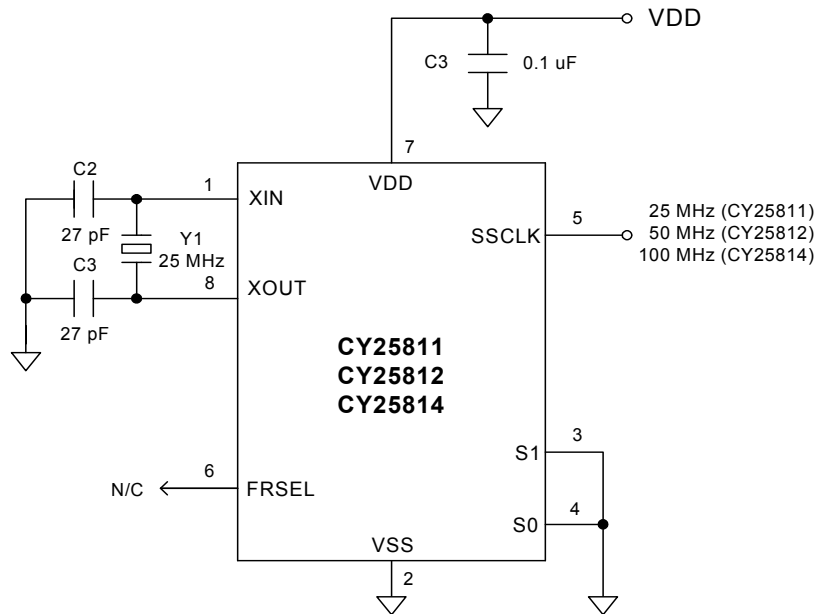

## Ordering Information

Part Number	Package Type	Product Flow
<b>Pb-free Devices</b>		
CY25811SXC	8-pin SOIC	Commercial, 0 °C to 70 °C
CY25811SXCT	8-pin SOIC – Tape and Reel	Commercial, 0 °C to 70 °C
CY25811SXI	8-pin SOIC	Industrial, –40 °C to 85 °C
CY25811SXIT	8-pin SOIC – Tape and Reel	Industrial, –40 °C to 85 °C
CY25812SXC	8-pin SOIC	Commercial, 0 °C to 70 °C
CY25812SXCT	8-pin SOIC – Tape and Reel	Commercial, 0 °C to 70 °C
CY25812ZX	8-pin TSSOP	Commercial, 0 °C to 70 °C
CY25812ZXCT	8-pin TSSOP – Tape and Reel	Commercial, 0 °C to 70 °C
CY25814SXC	8-pin SOIC	Commercial, 0 °C to 70 °C
CY25814SXCT	8-pin SOIC – Tape and Reel	Commercial, 0 °C to 70 °C
CY25814SXI	8-pin SOIC	Industrial, –40 °C to 85 °C
CY25814SXIT	8-pin SOIC – Tape and Reel	Industrial, –40 °C to 85 °C

## Ordering Code Definitions

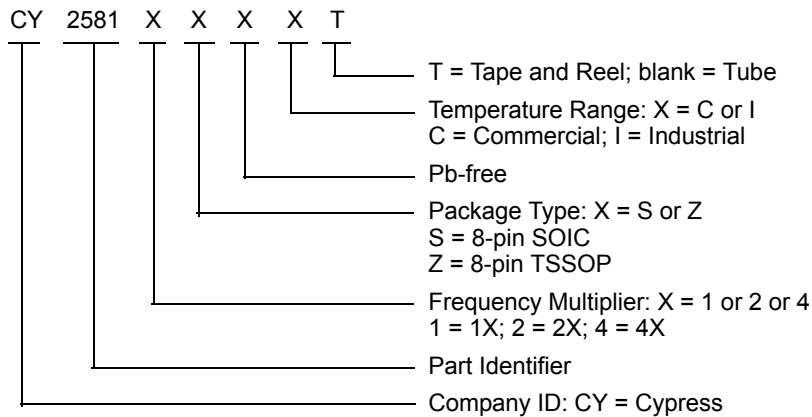

Package Drawing and Dimensions

Figure 5. 8-pin SOIC (150-Mils) S08.15/SZ08.15, 51-85066

1. DIMENSIONS IN INCHES[MM] MIN. MAX.
2. PIN 1 ID IS OPTIONAL, ROUND ON SINGLE LEADFRAME RECTANGULAR ON MATRIX LEADFRAME
3. REFERENCE JEDEC MS-012
4. PACKAGE WEIGHT 0.07gms

PART #	
S08.15	STANDARD PKG
SZ08.15	LEAD FREE PKG
SW8.15	LEAD FREE PKG

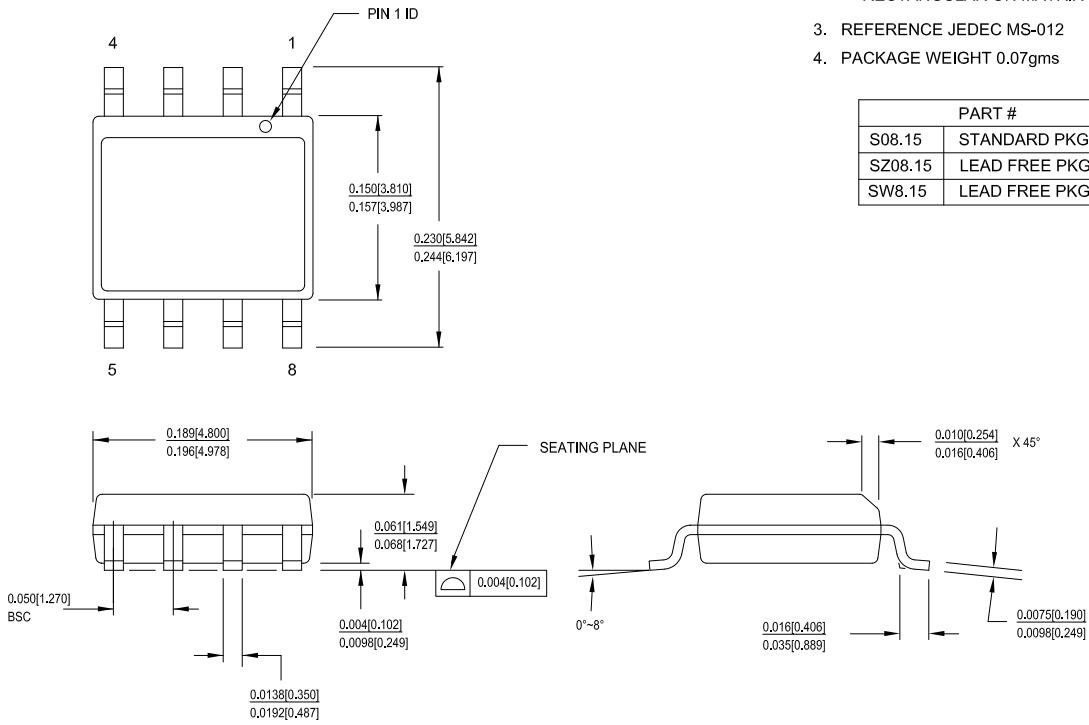

51-85066 \*F

Package Drawing and Dimensions (continued)

Figure 6. 8-pin TSSOP (4.40 mm Body) Z08.173/ZZ08.173, 51-85093

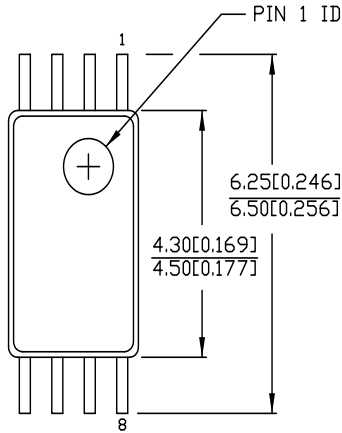

DIMENSIONS IN MM [INCHES] MIN. MAX.

REFERENCE JEDEC MO-153

PART #	
Z08.173	STANDARD PKG.
ZZ08.173	LEAD FREE PKG.

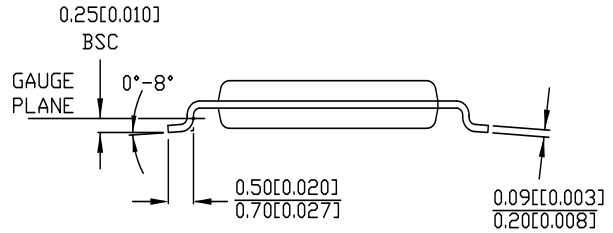
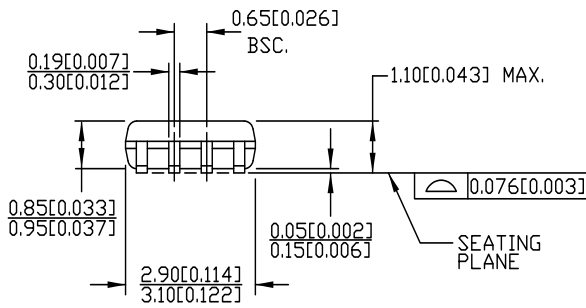

51-85093 \*E

### Acronyms

Acronym	Description
CD-ROM	compact disc, read only memory
DVD	digital versatile/video disc
EMI	electromagnetic interference
ESD	electrostatic discharge
FM	frequency modulation
LAN	local area network
LCD	liquid crystal display
PLL	phase locked loop
SOIC	small outline integrated circuit
SSC	spread spectrum clock
SSCG	spread spectrum clock generator
TSSOP	thin shrink small outline package
VCD	video compact disc
VCO	voltage controlled oscillator
WAN	wide area network

### Document Conventions

#### Units of Measure

Symbol	Unit of Measure
°C	degree Celsius
dB	decibels
MHz	Mega Hertz
μF	micro Farad
mA	milli Amperes
mm	milli meter
ms	milli seconds
mW	milli Watts
ns	nano seconds
%	percent
pF	pico Farad
ps	pico seconds
V	Volts

Document History Page

Document Title: CY25811/12/14, Spread Spectrum Clock Generator Document Number: 38-07112				
Revision	ECN	Orig. of Change	Submission Date	Description of Change
**	107516	NDP	06/14/02	Converted from IMI to Cypress
*A	108002	NDP	06/29/02	Deleted Junction Temp. in Absolute Maximum Ratings
*B	121578	RGL	01/29/03	Converted from Word to FrameMaker Added 8-pin TSSOP package in Commercial Temp. only Added an Industrial Temperature Range to all existing 8-pin SOIC packages
*C	125550	RGL	05/14/03	Changed IDD values from 19.6/22/27.2 to 25/30/35 in Commercial Grade DC Specs table Changed IDD values from 24/26.5/33 to 26/32/37 in Industrial grade DC Specs table Changed T <sub>CCJ1/2</sub> values from 675/260 to 800/450 in Commercial grade AC Specs table Changed T <sub>CCJ1</sub> value from 350 to 650 in Industrial grade AC Specs table
*D	131941	RGL	12/24/03	Removed automotive in the Applications section Changed the Output Clock Duty Cycle (T <sub>DCOUT</sub> ) from min. 45 and max. 55 to 40 and 60% respectively for both industrial and commercial grade Changed the min. Input Low Voltage (V <sub>IL</sub> ) from 0.15V <sub>DD</sub> to 0.13V <sub>DD</sub> Removed preliminary from the industrial AC/DC Electrical Specifications table
*E	231057	RGL	See ECN	Added Pb Free Devices
*F	1499165	KVM	See ECN	Updated Ordering Information table Corrected jitter values in features section on page 1 Changed:VDD from ±5% to ±10%, CIN1 min from 6 to 3.5 pF, CIN2 min from 3.5 to 2.8 pF, TF1 min from 2 to 1.6 ns, and TF2 min from 1.0 to 0.8 ns. Commercial grade: IDD1 max from 25 to 28 mA, IDD2 max from 30 to 33 mA, IDD3 max from 35 to 40 mA, TCCJ2 from 450 to 480 ps, TCCJ4 from 380 to 450 ps, and TCCJ5 from 380 to 550 ps Industrial grade: IDD1 max from 26 to 28 mA, IDD2 max from 32 to 33 mA, IDD3 max from 37 to 41 mA, TCCJ2 from 400 to 630 ps, and TCCJ3 from 400 to 520 ps
*G	2592288	CXQ /PYRS	10/23/08	Removed Pb package devices from Ordering Table
*H	2761988	CXQ	09/10/09	Removed reference to non-existent "Automotive" version. Fixed typo in DC spec table for VDD from min of 3.97 to 2.97. Fixed typo for PLL Lock time conditions. Removed CY25812SXI, CY25812SXIT, CY25814ZXC, and CY25814ZXT from Ordering Information.
*I	2887509	CXQ	03/04/2010	Updated MSL value in <a href="#">Absolute Maximum Conditions</a> Added <a href="#">Contents</a> Updated 8-pin SOIC and 8-pin TSSOP package drawings. Updated URLs in <a href="#">Sales, Solutions, and Legal Information</a>
*J	3339686	PURU	08/08/2011	Added <a href="#">Ordering Code Definitions</a> . Updated <a href="#">Package Drawing and Dimensions</a> . Added <a href="#">Acronyms and Units of Measure</a> . Updated in new template.
*K	4499792	TAVA	09/11/2014	Updated <a href="#">Package Drawing and Dimensions</a> : spec 51-85066 – Changed revision from *E to *F. spec 51-85093 – Changed revision from *C to *D. Updated in new template. Completing Sunset Review.
*L	4587350	TAVA	12/05/2014	Added related documentation hyperlink in page 1. Updated package diagram



## Sales, Solutions, and Legal Information

### Worldwide Sales and Design Support

Cypress maintains a worldwide network of offices, solution centers, manufacturer's representatives, and distributors. To find the office closest to you, visit us at [Cypress Locations](#).

#### Products

<a href="#">Automotive</a>	<a href="http://cypress.com/go/automotive">cypress.com/go/automotive</a>
<a href="#">Clocks &amp; Buffers</a>	<a href="http://cypress.com/go/clocks">cypress.com/go/clocks</a>
<a href="#">Interface</a>	<a href="http://cypress.com/go/interface">cypress.com/go/interface</a>
<a href="#">Lighting &amp; Power Control</a>	<a href="http://cypress.com/go/powerpsoc">cypress.com/go/powerpsoc</a> <a href="http://cypress.com/go/plc">cypress.com/go/plc</a>
<a href="#">Memory</a>	<a href="http://cypress.com/go/memory">cypress.com/go/memory</a>
<a href="#">PSoC</a>	<a href="http://cypress.com/go/psoc">cypress.com/go/psoc</a>
<a href="#">Touch Sensing</a>	<a href="http://cypress.com/go/touch">cypress.com/go/touch</a>
<a href="#">USB Controllers</a>	<a href="http://cypress.com/go/USB">cypress.com/go/USB</a>
<a href="#">Wireless/RF</a>	<a href="http://cypress.com/go/wireless">cypress.com/go/wireless</a>

#### PSoC<sup>®</sup> Solutions

[psoc.cypress.com/solutions](http://psoc.cypress.com/solutions)  
[PSoC 1](#) | [PSoC 3](#) | [PSoC 4](#) | [PSoC 5LP](#)

#### Cypress Developer Community

[Community](#) | [Forums](#) | [Blogs](#) | [Video](#) | [Training](#)

#### Technical Support

[cypress.com/go/support](http://cypress.com/go/support)

---

© Cypress Semiconductor Corporation, 2001-2014. The information contained herein is subject to change without notice. Cypress Semiconductor Corporation assumes no responsibility for the use of any circuitry other than circuitry embodied in a Cypress product. Nor does it convey or imply any license under patent or other rights. Cypress products are not warranted nor intended to be used for medical, life support, life saving, critical control or safety applications, unless pursuant to an express written agreement with Cypress. Furthermore, Cypress does not authorize its products for use as critical components in life-support systems where a malfunction or failure may reasonably be expected to result in significant injury to the user. The inclusion of Cypress products in life-support systems application implies that the manufacturer assumes all risk of such use and in doing so indemnifies Cypress against all charges.

Any Source Code (software and/or firmware) is owned by Cypress Semiconductor Corporation (Cypress) and is protected by and subject to worldwide patent protection (United States and foreign), United States copyright laws and international treaty provisions. Cypress hereby grants to licensee a personal, non-exclusive, non-transferable license to copy, use, modify, create derivative works of, and compile the Cypress Source Code and derivative works for the sole purpose of creating custom software and or firmware in support of licensee product to be used only in conjunction with a Cypress integrated circuit as specified in the applicable agreement. Any reproduction, modification, translation, compilation, or representation of this Source Code except as specified above is prohibited without the express written permission of Cypress.

Disclaimer: CYPRESS MAKES NO WARRANTY OF ANY KIND, EXPRESS OR IMPLIED, WITH REGARD TO THIS MATERIAL, INCLUDING, BUT NOT LIMITED TO, THE IMPLIED WARRANTIES OF MERCHANTABILITY AND FITNESS FOR A PARTICULAR PURPOSE. Cypress reserves the right to make changes without further notice to the materials described herein. Cypress does not assume any liability arising out of the application or use of any product or circuit described herein. Cypress does not authorize its products for use as critical components in life-support systems where a malfunction or failure may reasonably be expected to result in significant injury to the user. The inclusion of Cypress' product in a life-support systems application implies that the manufacturer assumes all risk of such use and in doing so indemnifies Cypress against all charges.

Use may be limited by and subject to the applicable Cypress software license agreement.

## X-ON Electronics

Largest Supplier of Electrical and Electronic Components

*Click to view similar products for [Phase Locked Loops - PLL category](#):*

*Click to view products by [Cypress manufacturer](#):*

Other Similar products are found below :

[ADF4152HVBCPZ-RL7](#) [HMC440QS16GTR](#) [LC72135MA-Q-AE](#) [SL28EB725ALI](#) [HMC698LP5ETR](#) [HMC699LP5ETR](#) [HMC700LP4TR](#)  
[LC7185-8750-E](#) [MB15E07SLPFV1-G-BND-6E1](#) [XRT8001ID-F](#) [ATA8404C-6DQY-66](#) [PI6C2409-1HWE](#) [ATA8405C-6DQY-66](#)  
[MAX2870ETJ+T](#) [PI6C2409-1HWEX](#) [CYW170-01SXC](#) [HMC764LP6CETR](#) [HMC767LP6CETR](#) [HMC820LP6CETR](#) [HMC828LP6CETR](#)  
[HMC834LP6GETR](#) [ispPAC-CLK5410D-01SN64C](#) [SI4113-D-GM](#) [82V3002APVG](#) [PI6C2405A-1WE](#) [CY22050KFI](#) [CY25200KFZXC](#)  
[CY29973AXI](#) [CY2XP22ZXI](#) [W232ZXC-10](#) [CDCE937QPWRQ1](#) [CY2077FZXI](#) [CY2546FC](#) [CY2XF23FLXIT](#) [CYISM560BSXC](#)  
[LMX2430TMX/NOPB](#) [HMC837LP6CETR](#) [HMC831LP6CETR](#) [ATA8404C-6DQY-66](#) [ADF4155BCPZ-RL7](#) [MB15E07SRPFT-G-BNDE1](#)  
[NB3N5573DTG](#) [MAX2660EUT+T](#) [SI4123-D-GT](#) [SI4112-D-GM](#) [NB4N441MNR2G](#) [9DB433AGILFT](#) [ADF4116BRUZ-REEL7](#)  
[ADF4153ABCPZ](#) [MAX2682EUT+T](#)