

TOSHIBA CMOS Digital Integrated Circuit Silicon Monolithic

TC74HCT540AP, TC74HCT540AF TC74HCT541AP, TC74HCT541AF

Octal Bus Buffer with TTL Input Level

TC74HCT540AP/AF	Inverting, 3-State Outputs
TC74HCT541AP/AF	Non-Inverting, 3-State Outputs

The TC74HCT540A/TC74HCT541A are high speed CMOS OCTAL BUS BUFFERS fabricated with silicon gate C²MOS technology.

These devices may be used as a level converter for interfacing TTL or NMOS to High Speed CMOS. The inputs are compatible with TTL, NMOS and CMOS output voltage levels.

They achieve the high speed operation similar to equivalent LSTTL while maintaining the CMOS low power dissipation.

The TC74HCT540A is an inverting type, and the TC74HCT541A is a non-inverting type.

When either $\overline{G1}$ or $\overline{G2}$ are high, the terminal outputs are in the high-impedance state.

All inputs are equipped with protection circuits against static discharge or transient excess voltage.

Features

- High speed: $t_{pd} = 10 \text{ ns}$ (typ.) at $V_{CC} = 5 \text{ V}$
- Low power dissipation: $I_{CC} = 4 \mu\text{A}$ (max) at $T_a = 25^\circ\text{C}$
- Compatible with TTL outputs: $V_{IL} = 0.8 \text{ V}$ (max)
 $V_{IH} = 2.0 \text{ V}$ (min)
- Wide interfacing ability: LSTTL, NMOS, CMOS
- Output drive capability: 15 LSTTL loads
- Symmetrical output impedance: $|I_{OH}| = I_{OL} = 6 \text{ mA}$ (min)
- Balanced propagation delays: $t_{pLH} \approx t_{pHL}$
- Pin and function compatible with 74LS540/541

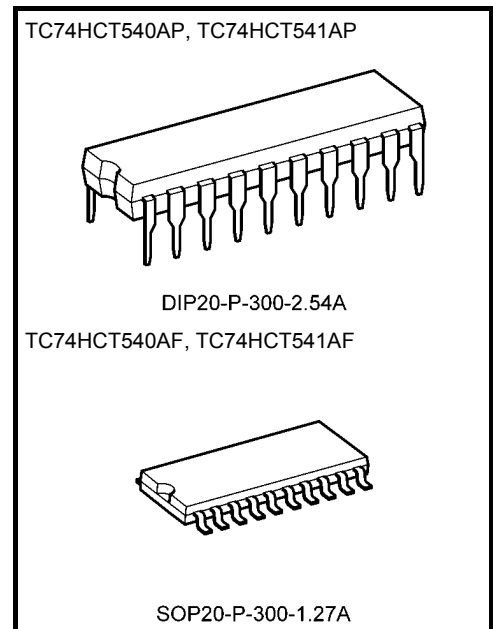

Weight	
DIP20-P-300-2.54A	: 1.30 g (typ.)
SOP20-P-300-1.27A	: 0.22 g (typ.)

Start of commercial production
1988-11

Pin Assignment

TC74HCT540A

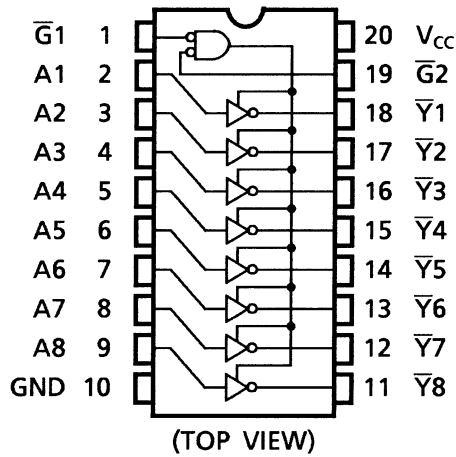

TC74HCT541A

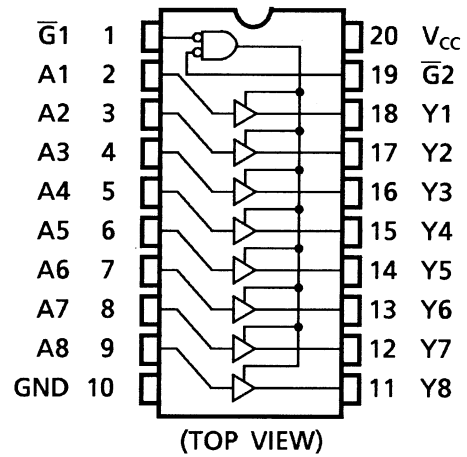

IEC Logic Symbol

TC74HCT540A

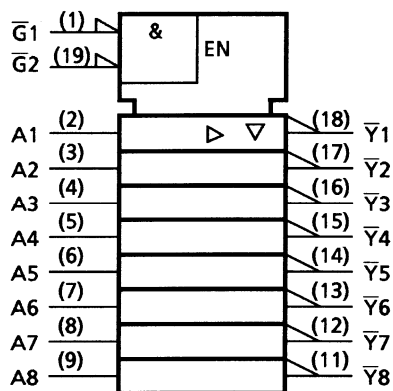

TC74HCT541A

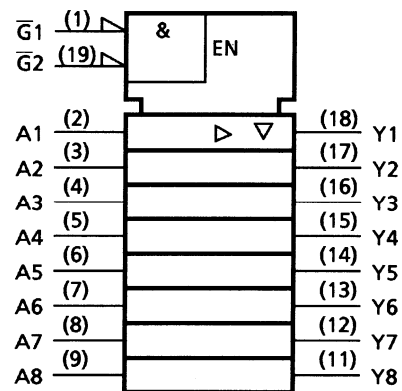

Truth Table

Inputs			Outputs	
$\overline{G1}$	$\overline{G2}$	A_n	Y_n^*	\overline{Y}_n^*
H	X	X	Z	Z
X	H	X	Z	Z
L	L	H	H	L
L	L	L	L	H

X: Don't care

Z: High impedance

*: Y_n HCT541A

\overline{Y}_n HCT540A

Absolute Maximum Ratings (Note 1)

Characteristics	Symbol	Rating	Unit
Supply voltage range	V_{CC}	-0.5 to 7	V
DC input voltage	V_{IN}	-0.5 to $V_{CC} + 0.5$	V
DC output voltage	V_{OUT}	-0.5 to $V_{CC} + 0.5$	V
Input diode current	I_{IK}	± 20	mA
Output diode current	I_{OK}	± 20	mA
DC output current	I_{OUT}	± 35	mA
DC V_{CC} /ground current	I_{CC}	± 75	mA
Power dissipation	P_D	500 (DIP) (Note 2)/180 (SOP)	mW
Storage temperature	T_{stg}	-65 to 150	°C

Note 1: Exceeding any of the absolute maximum ratings, even briefly, lead to deterioration in IC performance or even destruction.

Using continuously under heavy loads (e.g. the application of high temperature/current/voltage and the significant change in temperature, etc.) may cause this product to decrease in the reliability significantly even if the operating conditions (i.e. operating temperature/current/voltage, etc.) are within the absolute maximum ratings and the operating ranges.

Please design the appropriate reliability upon reviewing the Toshiba Semiconductor Reliability Handbook ("Handling Precautions"/"Derating Concept and Methods") and individual reliability data (i.e. reliability test report and estimated failure rate, etc).

Note 2: 500 mW in the range of $T_a = -40$ to 65°C . From $T_a = 65$ to 85°C a derating factor of -10 mW/°C shall be applied until 300 mW.

Operating Ranges (Note)

Characteristics	Symbol	Rating	Unit
Supply voltage	V_{CC}	4.5 to 5.5	V
Input voltage	V_{IN}	0 to V_{CC}	V
Output voltage	V_{OUT}	0 to V_{CC}	V
Operating temperature	T_{opr}	-40 to 85	°C
Input rise and fall time	t_r, t_f	0 to 500	ns

Note: The operating ranges must be maintained to ensure the normal operation of the device. Unused inputs must be tied to either V_{CC} or GND.

Electrical Characteristics

DC Characteristics

Characteristics	Symbol	Test Condition	$T_a = 25^\circ\text{C}$			$T_a = -40$ to 85°C		Unit		
			V_{CC} (V)	Min	Typ.	Max	Min		Max	
High-level input voltage	V_{IH}	—	4.5 to 5.5	2.0	—	—	2.0	—	V	
Low-level input voltage	V_{IL}	—	4.5 to 5.5	—	—	0.8	—	0.8	V	
High-level output voltage	V_{OH}	$V_{IN} = V_{IH}$ or V_{IL}	$I_{OH} = -20 \mu\text{A}$	4.5	4.4	4.5	—	4.4	—	V
			$I_{OH} = -6 \text{ mA}$	4.5	4.18	4.31	—	4.13	—	
Low-level output voltage	V_{OL}	$V_{IN} = V_{IH}$ or V_{IL}	$I_{OL} = 20 \mu\text{A}$	4.5	—	0.0	0.1	—	0.1	V
			$I_{OL} = 6 \text{ mA}$	4.5	—	0.17	0.26	—	0.33	
3-state output off-state current	I_{OZ}	$V_{IN} = V_{IH}$ or V_{IL} $V_{OUT} = V_{CC}$ or GND	5.5	—	—	± 0.5	—	± 5.0	μA	
Input leakage current	I_{IN}	$V_{IN} = V_{CC}$ or GND	5.5	—	—	± 0.1	—	± 1.0	μA	
Quiescent supply current	I_{CC}	$V_{IN} = V_{CC}$ or GND	5.5	—	—	4.0	—	40.0	μA	
	I_C	Per input: $V_{IN} = 0.5 \text{ V}$ or 2.4 V Other input: V_{CC} or GND	5.5	—	—	2.0	—	2.9	mA	

AC Characteristics (input: $t_r = t_f = 6$ ns)

Characteristics	Symbol	Test Condition	Ta = 25°C			Ta = -40 to 85°C		Unit		
			CL (pF)	V _{CC} (V)	Min	Typ.	Max		Min	Max
Output transition time	t _{TLH}	—	50	4.5	—	7	12	—	15	ns
	t _{THL}			5.5	—	6	11	—	14	
Propagation delay time (TC74HCT540A)	t _{pLH}	—	50	4.5	—	12	20	—	25	ns
				5.5	—	9	18	—	23	
	t _{pHL}		150	4.5	—	17	26	—	33	
				5.5	—	14	24	—	30	
Propagation delay time (TC74HCT541A)	t _{pLH}	—	50	4.5	—	14	23	—	29	ns
				5.5	—	11	21	—	27	
	t _{pHL}		150	4.5	—	19	29	—	36	
				5.5	—	16	27	—	33	
Output enable time	t _{pZL}	R _L = 1 kΩ	50	4.5	—	18	30	—	38	ns
				5.5	—	16	27	—	35	
	t _{pZH}		150	4.5	—	23	36	—	45	
				5.5	—	21	33	—	41	
Output disable time	t _{pLZ}	R _L = 1 kΩ	50	4.5	—	18	30	—	38	ns
	t _{pHZ}			5.5	—	16	27	—	35	
Input capacitance	C _{IN}	—	—	—	5	10	—	10	pF	
Output capacitance	C _{OUT}	—	—	—	10	—	—	—	pF	
Power dissipation capacitance	C _{PD} (Note)	TC74HCT540A	—	—	35	—	—	—	pF	
		TC74HCT541A	—	—	31	—	—	—		

Note: C_{PD} is defined as the value of the internal equivalent capacitance which is calculated from the operating current consumption without load.

Average operating current can be obtained by the equation:

$$I_{CC}(\text{opr}) = C_{PD} \cdot V_{CC} \cdot f_{IN} + I_{CC}/8 \text{ (per bit)}$$

Package Dimensions

DIP20-P-300-2.54A

Unit : mm

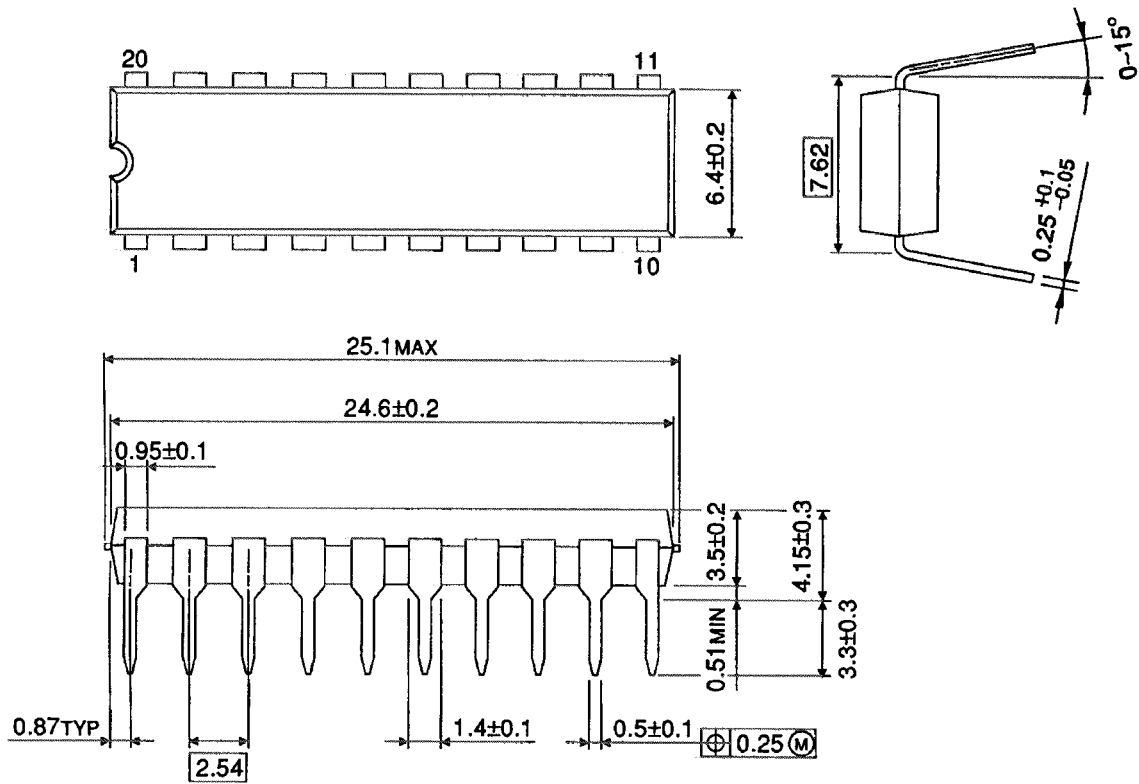

Weight: 1.30 g (typ.)

Package Dimensions

SOP20-P-300-1.27A

Unit: mm

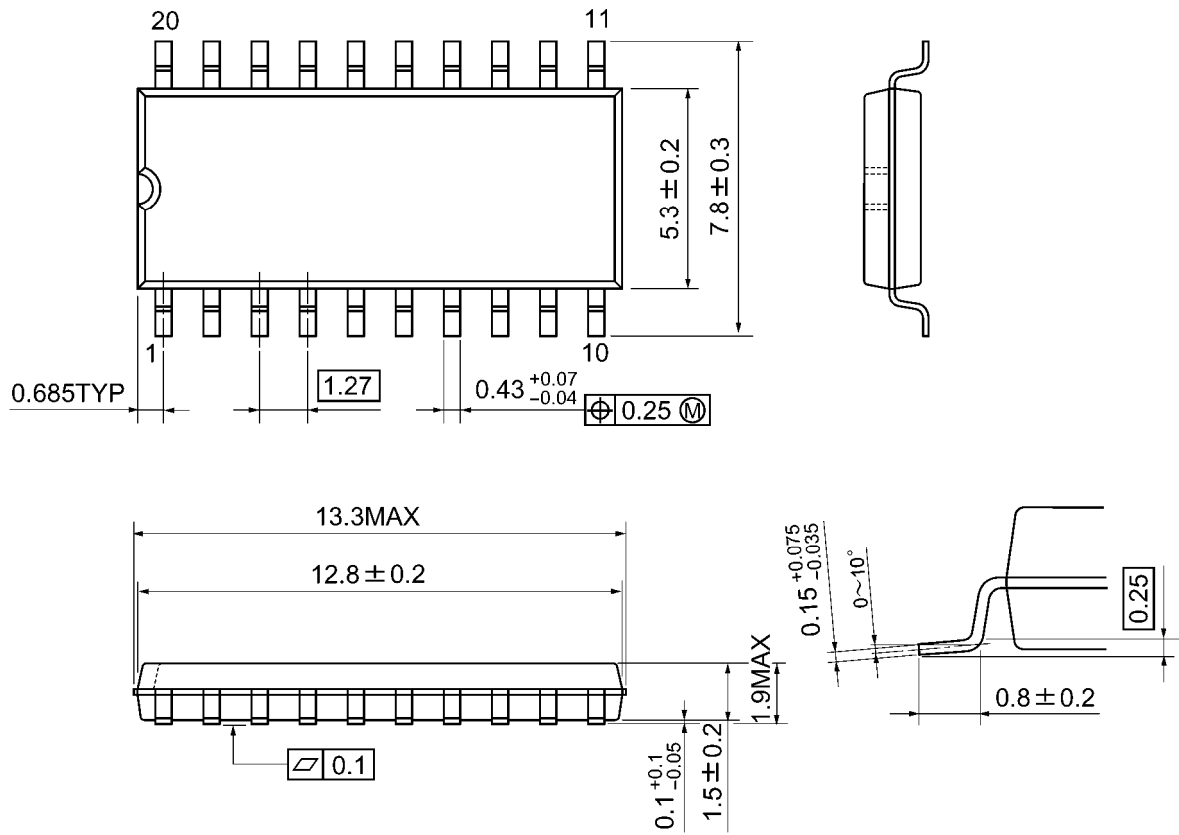

Weight: 0.22 g (typ.)

X-ON Electronics

Largest Supplier of Electrical and Electronic Components

Click to view similar products for [Buffers & Line Drivers](#) category:

Click to view products by [Toshiba](#) manufacturer:

Other Similar products are found below :

[5962-9217601MSA](#) [634810D](#) [875140G](#) [HEF4022BP](#) [HEF4043BP](#) [NL17SG125DFT2G](#) [NL17SZ126P5T5G](#) [NLU1GT126CMUTCG](#)
[NLU3G16AMX1TCG](#) [NLV27WZ125USG](#) [MC74HCT365ADTR2G](#) [BCM6306KMLG](#) [54FCT240CTDB](#) [Le87401NQC](#) [Le87402MQC](#)
[028192B](#) [042140C](#) [051117G](#) [070519XB](#) [065312DB](#) [091056E](#) [098456D](#) [NL17SG07DFT2G](#) [NL17SG17DFT2G](#) [NL17SG34DFT2G](#)
[NL17SZ07P5T5G](#) [NL17SZ125P5T5G](#) [NLU1GT126AMUTCG](#) [NLV27WZ16DFT2G](#) [5962-8982101PA](#) [5962-9052201PA](#) [74LVC07ADR2G](#)
[MC74VHC1G125DFT1G](#) [NL17SH17P5T5G](#) [NL17SZ125CMUTCG](#) [NLV17SZ07DFT2G](#) [NLV37WZ17USG](#) [NLVHCT244ADTR2G](#)
[NC7WZ17FHX](#) [74HCT126T14-13](#) [NL17SH125P5T5G](#) [NLV14049UBDTR2G](#) [NLV37WZ07USG](#) [74VHC541FT\(BE\)](#) [RHFAC244K1](#)
[74LVC1G17FW4-7](#) [74LVC1G126FZ4-7](#) [BCM6302KMLG](#) [74LVC1G07FZ4-7](#) [74LVC1G125FW4-7](#)