

# TC7S14F, TC7S14FU

## SCHMITT INVERTER

The TC7S14 is a high speed C<sup>2</sup>MOS SCHMITT INVERTER fabricated with silicon gate C<sup>2</sup>MOS technology. It achieves a high speed operation similar to equivalent LSTTL while maintaining the C<sup>2</sup>MOS low power dissipation.

Pin Configuration and function are the same as the TC7SU04F but input have 25% V<sub>CC</sub> hysteresis and with its schmitt trigger function, the TC7S14F can be used as line receivers which will receive slow input signal.

Input is equipped with protection circuits against static discharge or transient excess voltage.

Output currents are 1/2 compared to TC74HC series models.

### FEATURES

- High Speed .....  $t_{pd} = 11\text{ns}$  (Typ.) at  $V_{CC} = 5\text{V}$
- Low Power Dissipation .....  $I_{CC} = 1\mu\text{A}$  (Max.) at  $T_a = 25^\circ\text{C}$
- High Noise Immunity .....  $V_H = 1.1\text{V}$  at  $V_{CC} = 5\text{V}$
- Output Drive Capability ..... 5 LSTTL Loads
- Symmetrical Output Impedance ...  $|I_{OH}| = I_{OL} = 2\text{mA}$
- Balanced Propagation Delays .....  $t_{pLH} \doteq t_{pHL}$
- Wide Operating Voltage Range ...  $V_{CC}(\text{opr}) = 2\sim 6\text{V}$

### MAXIMUM RATINGS

CHARACTERISTIC	SYMBOL	RATING	UNIT
Supply Voltage Range	V <sub>CC</sub>	-0.5~7	V
DC Input Voltage	V <sub>IN</sub>	-0.5~V <sub>CC</sub> +0.5	V
DC Output Voltage	V <sub>OUT</sub>	-0.5~V <sub>CC</sub> +0.5	V
Input Diode Current	I <sub>IK</sub>	±20	mA
Output Diode Current	I <sub>OK</sub>	±20	mA
DC Output Current	I <sub>OUT</sub>	±12.5	mA
DC V <sub>CC</sub> /Ground Current	I <sub>CC</sub>	±50	mA
Power Dissipation	P <sub>D</sub>	200	mW
Storage Temperature	T <sub>stg</sub>	-65~150	°C
Lead Temperature (10s)	T <sub>L</sub>	260	°C

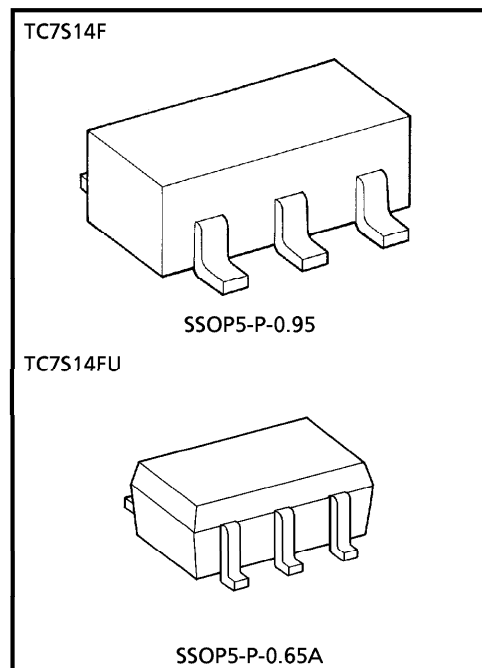

Weight SSOP5-P-0.95 : 0.016g (Typ.)  
 SSOP5-P-0.65A : 0.006g (Typ.)

### MARKING

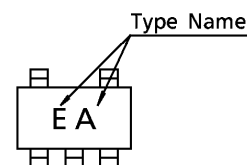

**LOGIC DIAGRAM**

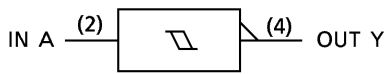

**PIN ASSIGNMENT (TOP VIEW)**

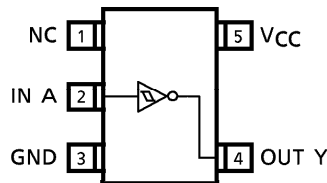

**TRUTH TABLE**

A	Y
L	H
H	L

**RECOMMENDED OPERATING CONDITIONS**

CHARACTERISTIC	SYMBOL	RATING	UNIT
Supply Voltage	$V_{CC}$	2~6	V
Input Voltage	$V_{IN}$	0~ $V_{CC}$	V
Output Voltage	$V_{OUT}$	0~ $V_{CC}$	V
Operating Temperature	$T_{opr}$	-40~85	°C

**DC ELECTRICAL CHARACTERISTICS**

CHARACTERISTIC	SYMBOL	TEST CONDITION	$T_a = 25^\circ\text{C}$						$T_a = -40\sim 85^\circ\text{C}$		UNIT			
			$V_{CC}$	MIN.	TYP.	MAX.	MIN.	MAX.						
Positive Threshold Voltage	$V_P$	—	2.0	1.0	1.25	1.5	1.0	1.5	V					
			4.5	2.3	2.7	3.15	2.3	3.15						
			6.0	3.0	3.5	4.2	3.0	4.2						
Negative Threshold Voltage	$V_N$	—	2.0	0.3	0.65	0.9	0.3	0.9	V					
			4.5	1.13	1.6	2.0	1.13	2.0						
			6.0	1.5	2.3	2.6	1.5	2.6						
Hysteresis Voltage	$V_H$	—	2.0	0.3	0.6	1.0	0.3	1.0	V					
			4.5	0.6	1.1	1.4	0.6	1.4						
			6.0	0.8	1.2	1.7	0.8	1.7						
High-Level Output Voltage	$V_{OH}$	$V_{IN} = V_{IL}$	$I_{OH} = -20\mu\text{A}$	2.0	1.9	2.0	—	1.9	—	V				
				4.5	4.4	4.5	—	4.4	—					
				6.0	5.9	6.0	—	5.9	—					
Low-Level Output Voltage	$V_{OL}$	$V_{IN} = V_{IH}$	$I_{OL} = 20\mu\text{A}$	2.0	—	0.0	0.1	—	0.1	V				
				4.5	—	0.0	0.1	—	0.1					
				6.0	—	0.0	0.1	—	0.1					
Input Leakage Current	$I_{IN}$	$V_{IN} = V_{CC}$ or GND		6.0	—	—	$\pm 0.1$	—	$\pm 1.0$	$\mu\text{A}$				
				Quiescent Supply Current	$I_{CC}$	$V_{IN} = V_{CC}$ or GND		6.0	—	—	1.0	—	10.0	$\mu\text{A}$

Output currents are 1/2 compared to TC74HC series models.

**AC ELECTRICAL CHARACTERISTICS (C<sub>L</sub> = 15pF, V<sub>CC</sub> = 5V, Ta = 25°C)**

CHARACTERISTIC	SYMBOL	TEST CONDITION	Ta = 25°C			UNIT
			MIN.	TYP.	MAX.	
Output Transition Time	t <sub>TLH</sub>	—	—	4	8	ns
	t <sub>THL</sub>					
Propagation Delay Time	t <sub>pLH</sub>	—	—	11	21	
	t <sub>pHL</sub>					

**AC ELECTRICAL CHARACTERISTICS (C<sub>L</sub> = 50pF, Input t<sub>r</sub> = t<sub>f</sub> = 6ns)**

CHARACTERISTIC	SYMBOL	TEST CONDITION	V <sub>CC</sub>	Ta = 25°C			Ta = -40~85°C		UNIT
				MIN.	TYP.	MAX.	MIN.	MAX.	
Output Transition Time	t <sub>TLH</sub> t <sub>THL</sub>	—	2.0	—	50	125	—	145	ns
			4.5	—	14	25	—	30	
			6.0	—	12	21	—	24	
Propagation Delay Time	t <sub>pLH</sub> t <sub>pHL</sub>	—	2.0	—	48	100	—	235	
			4.5	—	12	20	—	48	
			6.0	—	9	17	—	40	
Input Capacitance	C <sub>IN</sub>	—	—	5	10	—	10	pF	
Power Dissipation Capacitance	C <sub>pD</sub>	Note (1)	—	28	—	—	—		

Note (1) : C<sub>pD</sub> is defined as the value of internal equivalent capacitance which is calculated from the operating current consumption without load.

Average operating current can be obtained by the equation :

$$I_{CC (opr)} = C_{pD} \cdot V_{CC} \cdot f_{IN} + I_{CC}$$

**PACKAGE DIMENSIONS**  
SSOP5-P-0.95

Unit : mm



Weight : 0.016g (Typ.)

PACKAGE DIMENSIONS  
SSOP5-P-0.65A

Unit : mm

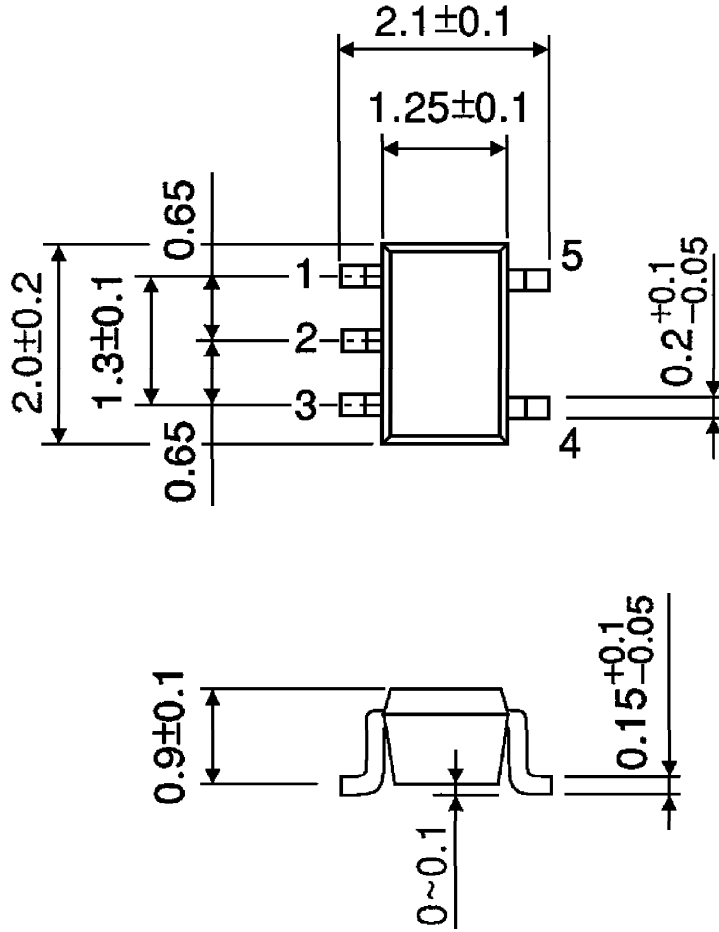

Weight : 0.006g (Typ.)

**RESTRICTIONS ON PRODUCT USE**

000707EBA

- TOSHIBA is continually working to improve the quality and reliability of its products. Nevertheless, semiconductor devices in general can malfunction or fail due to their inherent electrical sensitivity and vulnerability to physical stress. It is the responsibility of the buyer, when utilizing TOSHIBA products, to comply with the standards of safety in making a safe design for the entire system, and to avoid situations in which a malfunction or failure of such TOSHIBA products could cause loss of human life, bodily injury or damage to property. In developing your designs, please ensure that TOSHIBA products are used within specified operating ranges as set forth in the most recent TOSHIBA products specifications. Also, please keep in mind the precautions and conditions set forth in the "Handling Guide for Semiconductor Devices," or "TOSHIBA Semiconductor Reliability Handbook" etc..
- The TOSHIBA products listed in this document are intended for usage in general electronics applications (computer, personal equipment, office equipment, measuring equipment, industrial robotics, domestic appliances, etc.). These TOSHIBA products are neither intended nor warranted for usage in equipment that requires extraordinarily high quality and/or reliability or a malfunction or failure of which may cause loss of human life or bodily injury ("Unintended Usage"). Unintended Usage include atomic energy control instruments, airplane or spaceship instruments, transportation instruments, traffic signal instruments, combustion control instruments, medical instruments, all types of safety devices, etc.. Unintended Usage of TOSHIBA products listed in this document shall be made at the customer's own risk.
- The products described in this document are subject to the foreign exchange and foreign trade laws.
- The information contained herein is presented only as a guide for the applications of our products. No responsibility is assumed by TOSHIBA CORPORATION for any infringements of intellectual property or other rights of the third parties which may result from its use. No license is granted by implication or otherwise under any intellectual property or other rights of TOSHIBA CORPORATION or others.
- The information contained herein is subject to change without notice.

## X-ON Electronics

Largest Supplier of Electrical and Electronic Components

*Click to view similar products for [toshiba](#) manufacturer:*

Other Similar products are found below :

[TLP250\(F\)](#) [TC7W125FU\(TE12L,F\)](#) [TC7SBL384CFU,LF](#) [TLP183\(GB,E](#) [431392HB](#) [EMPP008Z](#) [TC58DVM92A5TA00](#) [TLP291\(TP,E\)](#)  
[TLP705A\(F\)](#) [TLP5214\(D4-TP,E](#) [TLP591B\(C,F\)](#) [2SA1943N\(S1,E,S\)](#) [TLP5754\(D4-TP,E](#) [TLP352\(LF1,F\)](#) [TLP2409\(F\)](#) [TLP109\(TPR,E\)](#)  
[TC4013BP\(N,F](#) [TCK112G,LF](#) [TLP184\(GB-TPL,E\(O](#) [TLP185\(GR-TPL,E\(O](#) [TLP108](#) [VFNC3S-2015PL](#) [VFS15-4007PL-W](#) [TLP7820\(D4-](#)  
[A,E](#) [TPH4R10ANL,L1Q](#) [SSM3J35AMFV,L3F](#) [THRIVECOVER](#) [1SS392\(TE85L,F\)](#) [TCK22971G,LF](#) [TK28A65W,S5X](#) [TK6A80E,S4X](#)  
[058399HB](#) [TORX177F,T](#) [TK31A60W,S4VX](#) [TLP190B\(U,C,F\)](#) [VFS15S-2015PL-W](#) [TK39N60W5,S1VF](#) [TLP2362\(E\)](#) [74VHC125FT](#)  
[TLP759\(LF1,J,F\)](#) [TLP5754\(D4,E](#) [TLP4026G\(F\)](#) [TK8A65W,S5X](#) [TC7W14FUTE12LF](#) [TB6568KQ\(O,8\)](#) [TLP2662\(F\)](#) [74HC138D](#)  
[SW89CN0-ZCC](#) [THGAF8T1T83BAIR](#) [SSM3K345R,LF](#)