



■ Features :

- Half-brick size (2.28"X2.4"X0.5") with industry standard pin out
- 2:1 wide input range
- Protections: Short circuit / Over current / Over voltage / Over temperature
- High efficiency up to 89%
- 1500VDC I/O isolation
- Built-in remote ON/OFF control
- Built-in remote sense function
- Trimming output $\pm 10\%$
- Five-sided shield metal case
- Optional heat sinks for extended operating temperature
- Output 2.5V/3.3V/15V available
- Approvals: UL / CUL / CE
- 3 years warranty



SPECIFICATION

MODEL		MHB150-48S05	MHB150-48S12	MHB150-48S24	
OUTPUT	DC VOLTAGE	5V	12V	24V	
	CURRENT RANGE	0 ~ 30A	0 ~ 12.5A	0 ~ 6.25A	
	RATED POWER	150W			
	RIPPLE & NOISE (max.) Note.2	100mVp-p	150mVp-p	240mVp-p	
	VOLTAGE ACCURACY Note.3	$\pm 1.0\%$			
	LINE REGULATION	$\pm 0.2\%$			
	LOAD REGULATION	$\pm 0.2\%$			
	SWITCHING FREQUENCY (Typ.)	500KHz			
	EXTERNAL TRIM ADJ. RANGE (Typ.)	$\pm 10\%$			
	EXTERNAL CAPACITIVE LOAD (max.)	30000uF	12500uF	6250uF	
INPUT	RATED DC INPUT	48VDC			
	VOLTAGE RANGE	36 ~ 75VDC			
	SURGE VOLTAGE (100ms max.)	100VDC			
	UNDER VOLTAGE LOCKOUT	Power up: 34VDC, Power down: 32.5VDC			
	EFFICIENCY (Typ.)	86%	89%	89%	
	DC CURRENT	FULL LOAD	3.7A	3.6A	3.6A
		NO LOAD	25mA		
FILTER	Pi-network				
PROTECTION	OUTPUT OVER CURRENT	110 ~ 140% rated output power Protection type : Over current limiting, recovers automatically after fault condition is removed			
	OUTPUT OVER VOLTAGE (Typ.)	115 ~ 140% rated output voltage Protection type : Output voltage clamp			
	OUTPUT SHORT CIRCUIT	Protection type : Can be continuous, recovers automatically after fault condition is removed			
	OVER TEMPERATURE	100°C $\pm 5^\circ\text{C}$ of case temperature			
FUNCTION OPERATING	REMOTE CONTROL	Please refer to "Remote ON/OFF Control" for details			
	OUTPUT TRIMMING	$\pm 10\%$, Please refer to "External Output Trimming" for details			
ENVIRONMENT	WORKING TEMPERATURE (Typ.)	-40 ~ +100°C ; Thermal shutdown at 100°C $\pm 5^\circ\text{C}$ of case temperature (please refer to "Thermal Curve")			
	WORKING HUMIDITY	0% ~ 95% RH max.			
	STORAGE TEMP., HUMIDITY	-55 ~ +105°C, 0 ~ 95% RH			
	TEMP. COEFFICIENT	$\pm 0.03\%/^\circ\text{C}$ (0~60°C)			
SAFETY & EMC (Note 4)	SAFETY STANDARDS	UL60950-1 approved			
	ISOLATION VOLTAGE	I/P-O/P:1500VDC, I/P-Case:1500VDC, O/P-Case:1500VDC			
	ISOLATION RESISTANCE	I/P-O/P:100M Ohms / 500VDC / 25°C / 70% RH			
	EMC EMISSION	Compliance to EN55022 (CISPR22) Class A with external components (please refer to "EMC Suggestion Circuit")			
OTHERS	EMC IMMUNITY	Compliance to EN61000-4-2,3,4,5,6,8; EN55024, light industry level, criteria A			
	CASE MATERIAL	Aluminum			
	MTBF	900K hrs typ. MIL-HDBK-217F (25°C)			
	DIMENSION	57.9*61*12.7mm (2.28**2.40**0.5") (L*W*H)			
	WEIGHT	100g			
NOTE	<p>1. All parameters NOT specially mentioned are measured at 48VDC input, rated load and 25°C of ambient temperature.</p> <p>2. Ripple & noise are measured at 20MHz of bandwidth by using a 12" twisted pair-wire terminated with a 1uf ceramic & 10uf tantalum capacitor across output.</p> <p>3. The power supply need to connect "+Vout" to "+R.S" and "-Vout" to "-R.S".</p> <p>4. The power supply is considered a component which will be installed into a final equipment. The final equipment must be re-confirmed that it still meets EMC directives. For guidance on how to perform these EMC tests, please refer to "EMI testing of component power supplies."</p>				

Mechanical Specification

Unit:inch[mm]

All Dimensions In Inches [mm]
 Tolerance Inches: X.XX= ±0.02, X.XXX= ±0.010
 Millimeters: X.X= ±0.5, X.XX=±0.25

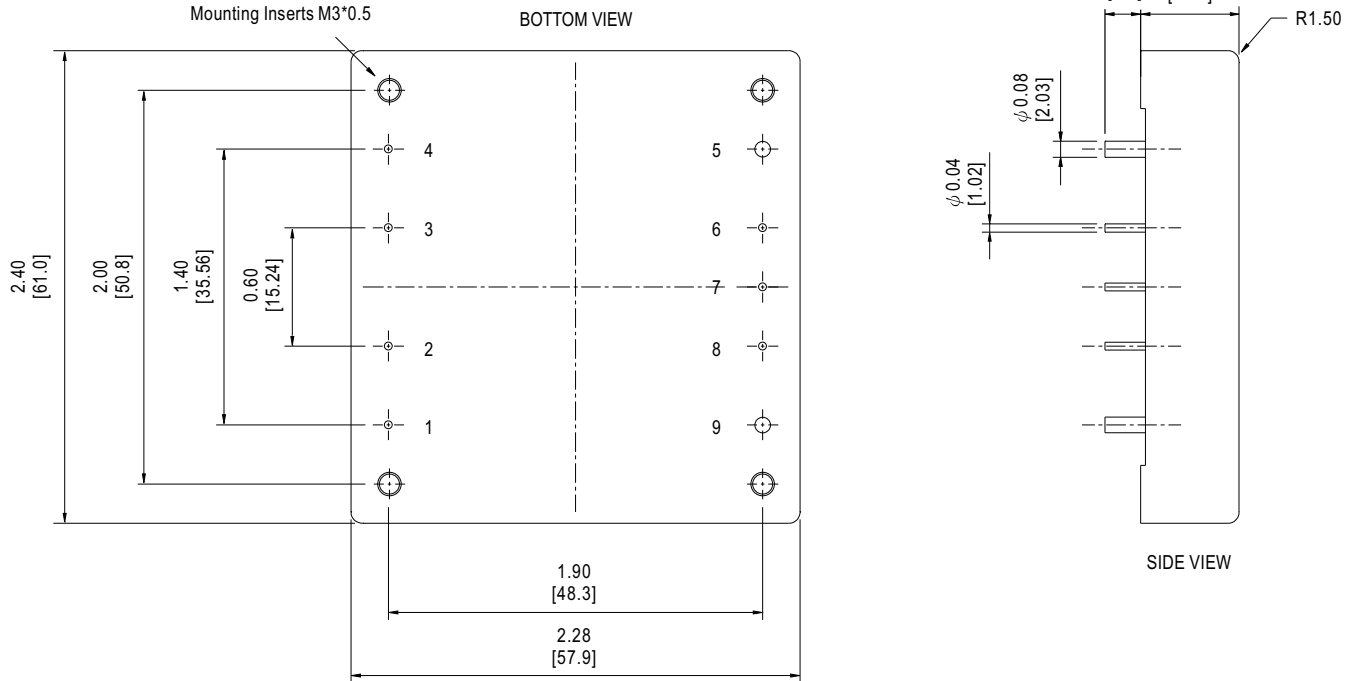

Pin No. Assignment

Pin No.	Assignment	Pin No.	Assignment	Pin No.	Assignment
1	+Vin	4	-Vin	7	Trim
2	R.C.	5	-Vout	8	+R.S.
3	Case	6	-R.S.	9	+Vout

Remote ON/OFF Control

The MHB150 series allow the user to switch the power ON and OFF electronically by their remote ON/OFF feature. The MHB150 series are available with "Positive Logic" (standard) or "Negative Logic" (option).

Logic table

Logic State(pin2)	Positive logic	Negative logic
Logic Low-Switch Closed	Power OFF(<0.8Vdc)	Power ON(<0.8Vdc)
Logic High-Switch Open	Power ON(Open circuit)	Power OFF(Open circuit)

Note: 1.Logic compatibility : R.C.(pin2) ~ -Vin(pin4).

2. Suffix "N" to the model number with Negative logic remote ON/OFF.

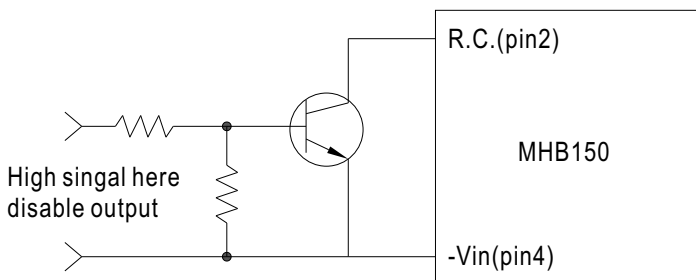

Example control circuit(positive logic)

External Output Trimming

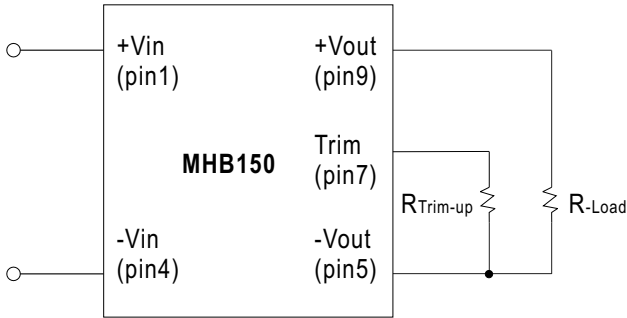

Figure 1 : Trim-up voltage setup

The value of $R_{Trim-up}$ defined as:

$$R_{Trim-up} = \frac{(R1-R2 \times (V_o - V_{o, nom}))}{(V_o - V_{o, nom})} \text{ (K}\Omega\text{)}$$

Where: $R_{Trim-up}$ is the external resistor in Kohm.

$V_{o, nom}$ is the nominal output voltage.

V_o is the desired output voltage.

$R1$ and $R2$ are inside the unit and list in Table 1

Output Voltage(V)	R1 (Kohm)	R2 (Kohm)
5V	5.8	3.3
12V	18.945	4.636
24V	41.442	6.977

Table 1

For example, to Trim-up the output

voltage of 5.0V model (MHB150-48S05)

by 8% to 5.4V, $R_{Trim-up}$ is calculated

as follows:

$$V_o - V_{o, nom} = 5.4 - 5.0 = 0.4V$$

$$R1 = 5.8 \text{ Kohm}$$

$$R2 = 3.3 \text{ Kohm}$$

$$R_{Trim-up} = \frac{5.8 - 3.3 \times 0.4}{0.4} = 11.2 \text{ (K}\Omega\text{)}$$

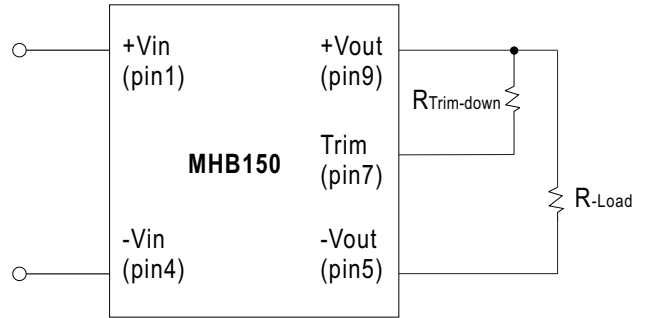

Figure 2 : Trim-down voltage setup

The value of $R_{Trim-down}$ defined as:

$$R_{Trim-down} = \frac{(R1 - R2 \times (V_o, nom - V_o))}{(V_o, nom - V_o)} \text{ (K}\Omega\text{)}$$

Where: $R_{Trim-down}$ is the external resistor in Kohm.

$V_{o, nom}$ is the nominal output voltage.

V_o is the desired output voltage.

$R1$ and $R2$ are inside the unit and list in Table 2.

Output Voltage(V)	R1 (Kohm)	R2 (Kohm)
5V	5.8	5.32
12V	86.45	60.1
24V	430	120

Table 2

For example, to Trim-down the output

Voltage of 5.0V model (MHB150-48S05)

by 8% to 4.6V, $R_{Trim-down}$ is

calculated as follows :

$$V_{o, nom} - V_o = 5.0 - 4.6 = 0.4 V$$

$$R1 = 5.8 \text{ Kohm}$$

$$R2 = 5.32 \text{ Kohm}$$

$$R_{Trim-down} = \frac{5.8 - 5.32 \times 0.4}{0.4} = 9.18 \text{ (K}\Omega\text{)}$$

Thermal Curve

The operating case temperature range of MHB-150 series is -40°C to +100°C. When operate the MHB-150 series, proper de-rating or cooling is needed.

The maximum case temperature under any operating condition should not be exceed 100°C. The following curve is the de-rating curve of MHB-150 series without heat sink.

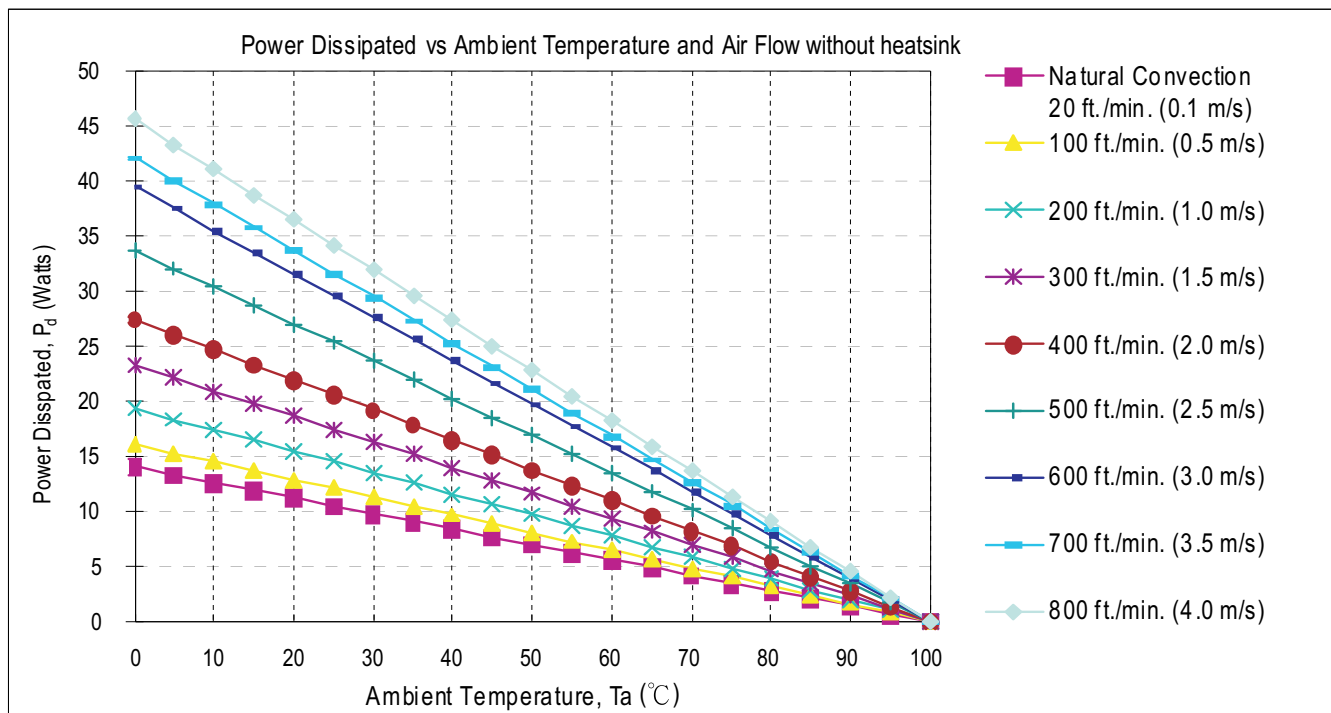

Air Flow Rate	Typical Rca	Air Flow Rate	Typical Rca
Natural convection 20ft./min. (0.1m/s)	7.12°C/W	500 ft./min. (2.5m/s)	2.96°C/W
100 ft./min. (0.5m/s)	6.21°C/W	600 ft./min. (3.0m/s)	2.53°C/W
200 ft./min. (1.0m/s)	5.17°C/W	700 ft./min. (3.5m/s)	2.37°C/W
300 ft./min. (1.5m/s)	4.29°C/W	800 ft./min. (4.0m/s)	2.19°C/W
400 ft./min. (2.0m/s)	3.64°C/W		

Rca : Thermal resistance from case to ambience

Example:

What is the minimum airflow necessary for a MHB150-48S12 operates at nominal line, an output current of 12.5A, and a maximum ambient temperature of 40°C?

Solution:

Given: Vin=48Vdc, Vo=12Vdc, Io=12.5A, η (unit efficiency)=89%

Determine Power dissipation (Pd):

$$P_d = P_i - P_o = P_o(1 - \eta) / \eta$$

$$P_d = 12 \times 12.5 \times (1 - 0.89) / 0.89 = 18.54 \text{ Watts}$$

Determine airflow:

Given: Pd=18.54W and Ta=40°C

Check Thermal Curve above:

minimum airflow= 500 ft./min.

Verifying: The maximum temperature rise $\Delta T = P_d \times R_{ca} = 18.54 \times 2.96 = 54.88^\circ\text{C}$

The maximum case temperature $T_c = T_a + \Delta T = 94.88^\circ\text{C} < 100^\circ\text{C}$

Where: The Rca is thermal resistance from case to ambience.

The Ta is ambient temperature and the Tc is case temperature.

■ Case Heat Sink (Optional)

Unit:mm

Model No.: M-C308 (Vertical Fins)

Model No.: M-C091(Horizontal Fins)

Model No.: M-C092 (Horizontal Fins)

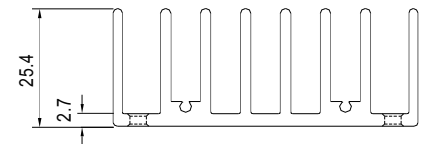
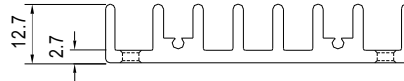
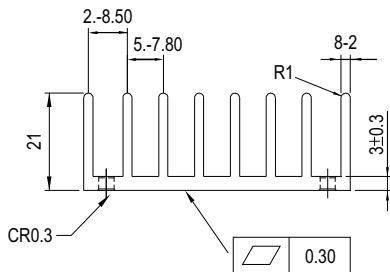
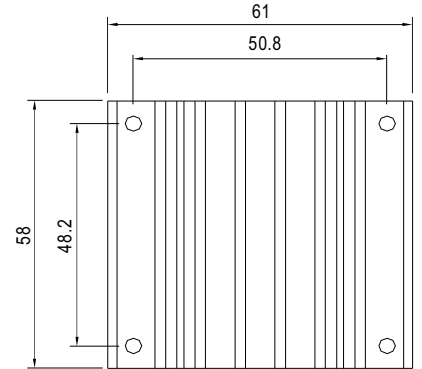
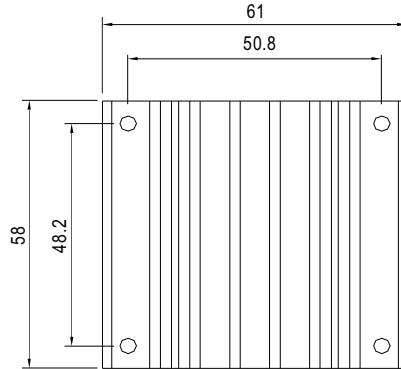
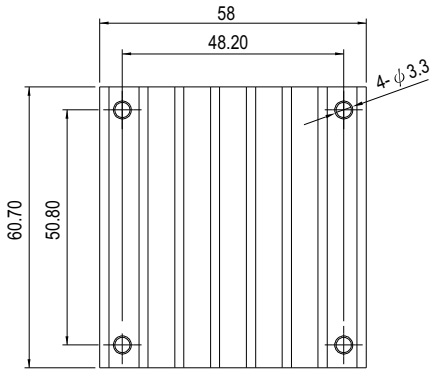
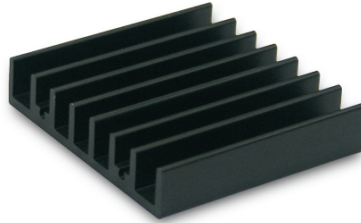
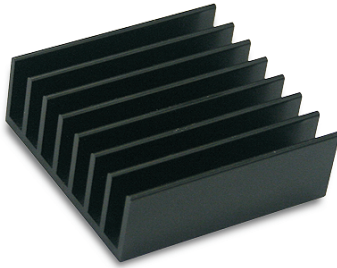

Rca:

- 3.90°C / W (typ.), at natural convection
- 1.74°C / W (typ.), at 100ft./min.(LFM)
- 1.33°C / W (typ.), at 200ft./min.(LFM)
- 1.12°C / W (typ.), at 300ft./min.(LFM)
- 0.97°C / W (typ.), at 400ft./min.(LFM)

Rca:

- 4.70°C / W (typ.), at natural convection
- 2.89°C / W (typ.), at 100ft./min.(LFM)
- 2.30°C / W (typ.), at 200ft./min.(LFM)
- 1.88°C / W (typ.), at 300ft./min.(LFM)
- 1.59°C / W (typ.), at 400ft./min.(LFM)

Rca:

- 3.00°C / W (typ.), at natural convection
- 1.44°C / W (typ.), at 100ft./min.(LFM)
- 1.17°C / W (typ.), at 200ft./min.(LFM)
- 1.04°C / W (typ.), at 300ft./min.(LFM)
- 0.95°C / W (typ.), at 400ft./min.(LFM)

■ Heatsink Assembly

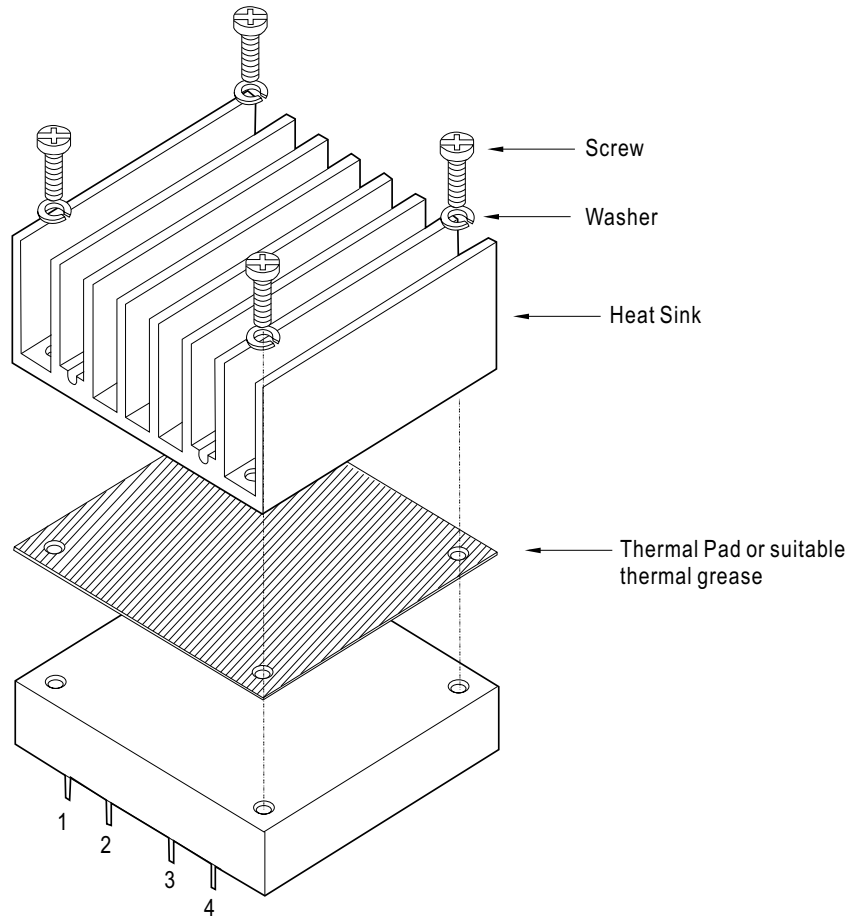

Heat Sink Order No.:
 M-C308
 M-C091
 M-C092
 Thermal Pad: 56.9x60x0.25mm
 Screw: SMP+SW M3x8L

■ EMC Suggestion Circuit

※Required external components to meet EN55022 class A conducted emission are as below:

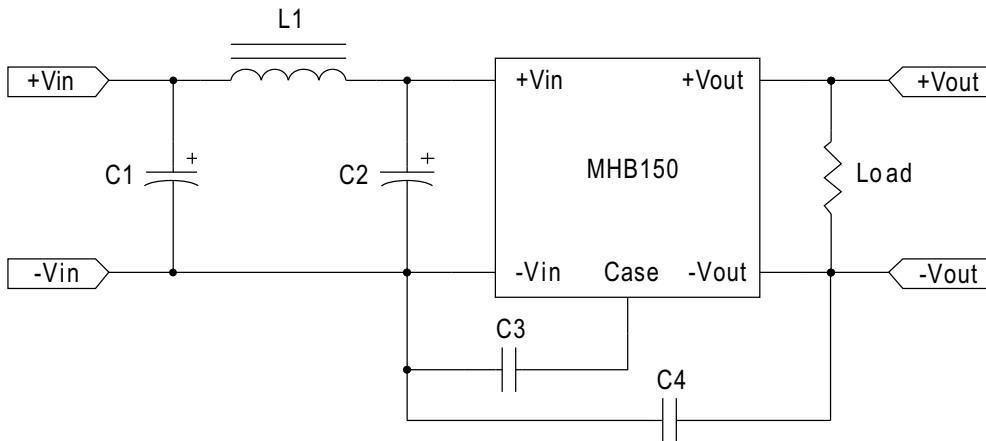

Model No.	C1	C2	C3	C4	L1
MHB150-48S□	47uF/100V ESR<0.17Ω	47uF/100V ESR<0.17Ω	1000pF	1000pF	3.4uH

□=05,12,24

X-ON Electronics

Largest Supplier of Electrical and Electronic Components

Click to view similar products for [Heat Sinks](#) category:

Click to view products by [Mean Well](#) manufacturer:

Other Similar products are found below :

[581102B00000G](#) [630-35ABT3](#) [656-15ABPE](#) [657-20ABPNE](#) [73452PPBA](#) [7721-13NG](#) [7G0011A](#) [FI306/SE](#) [PF720G](#) [A22-4026](#) [120-1873-007](#) [HAH10L](#) [1542256-2](#) [1542026-1](#) [1542616-1](#) [HS-2506-F1](#) [HS-87M0-F2](#) [218-40CTE3](#) [25-7520](#) [188854F00000G](#) [F-QB-F1](#) [APA501-60-003](#) [253-122ABE-22](#) [PSC22CB](#) [CLP-201](#) [CLP212SG](#) [CLP-7701G](#) [HAA072](#) [HAA083](#) [HAF10L](#) [HAQ10T](#) [D10100-28](#) [TO5-002D](#) [513101B02500G](#) [BDN183CBA01](#) [531202B0000](#) [HS-56M0-C1](#) [3-21053-4](#) [TX0506-1B](#) [TX1806B](#) [336614B-00000](#) [V2004X](#) [LAE66A3CB](#) [WA-DT2-101E](#) [511-3U](#) [017177](#) [530510B00000G](#) [6110BG](#) [73381PPBA](#) [73403PPBA](#)