

## Description

The AS78LXX series are three terminal positive regulators designed for a wide variety of applications including local, on-card regulation.

This series of regulators are complete with internal current limiting, thermal shutdown protection, and safe-area compensation which make them virtually immune from output overload. If adequate heat sinking are provided, these regulators can deliver output currents up to 100mA.

The AS78LXX series are available in TO-92 (bulk or ammo packing), SOT-89 and SOIC-8 packages.

## Features

- Output Current up to 100mA
- Fixed Output Voltages of 5V, 12V and 15V
- Output Voltage Accuracy of  $\pm 5\%$  over the Full Temperature Range
- Internal Short Circuit Current Limiting
- Internal Thermal Overload Protection
- No External Components
- Output Transistor Safe-area Protection

## Applications

- Consumer Electronics
- Microprocessor Power Supply
- Mother Board

## Pin Assignments

Z Package  
(TO-92(Bulk Packing))

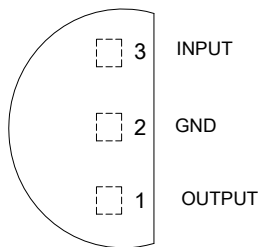

Z Package  
(TO-92(Ammo Packing))

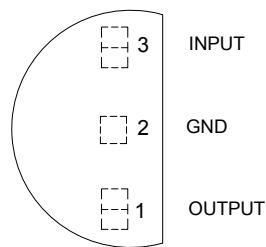

R Package  
(SOT-89 Option 1)

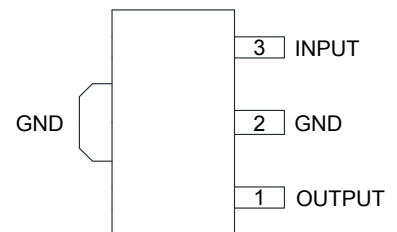

R Package  
(SOT-89 Option 2)

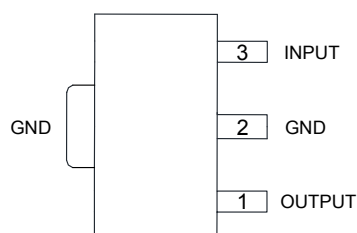

M Package  
(SOIC-8)

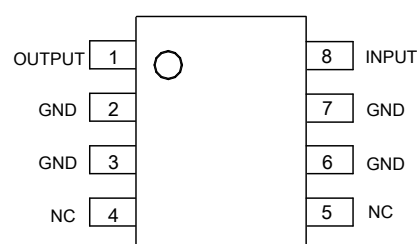

**Typical Applications Circuit**

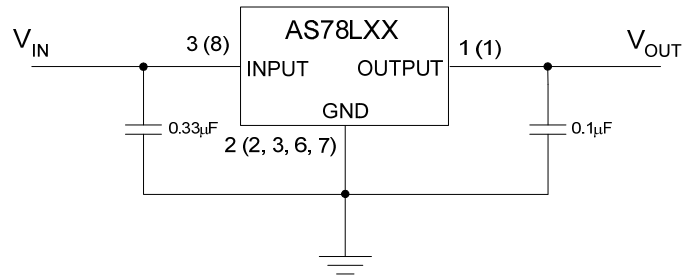

A (B)  
A for 3-pin    B for 8-pin

**Functional Block Diagram**

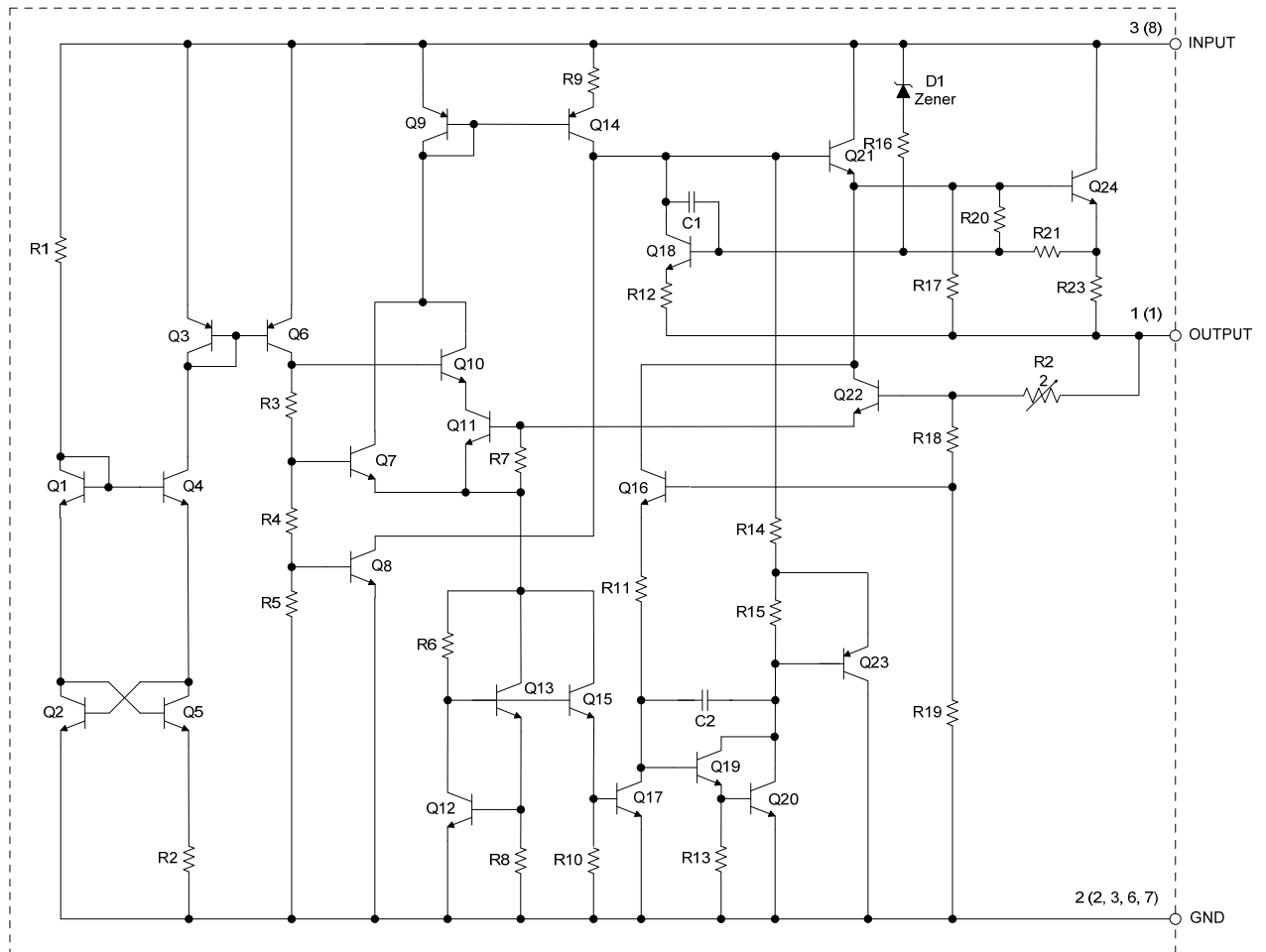

A (B)  
A for 3-pin    B for 8-pin

## Absolute Maximum Ratings (Note 1)

Symbol	Parameter	Rating		Unit
$V_{IN}$	Input Voltage	36		V
$T_J$	Operating Junction Temperature	150		°C
$T_{LEAD}$	Lead Temperature (Soldering, 10sec)	260		°C
$P_D$	Power Dissipation	750		mW
$T_{STG}$	Storage Temperature Range	-65 to 150		°C
$\theta_{JA}$	Thermal Resistance	TO-92	180	°C/W
ESD	ESD (Human Body Model)	2000		V
ESD	ESD (Machine Model)	200		V

Note 1: Stresses greater than those listed under "Absolute Maximum Ratings" may cause permanent damage to the device. These are stress ratings only, and functional operation of the device at these or any other conditions beyond those indicated under "Recommended Operating Conditions" is not implied. Exposure to "Absolute Maximum Ratings" for extended periods may affect device reliability.

## Recommended Operating Conditions

Symbol	Parameter		Min	Max	Unit
$V_{IN}$	Input Voltage	AS78L05		30	V
		AS78L12		36	
		AS78L15		36	
$T_J$	Operating Junction Temperature Range		-40	125	°C

## Electrical Characteristics

**AS78L05** (@  $V_{IN}=10V$ ,  $I_{OUT}=40mA$ ,  $C_{IN}=0.33\mu F$ ,  $C_{OUT}=0.1\mu F$ ,  $T_J=25^\circ C$ , **Bold** typeface applies over  $-40^\circ C \leq T_J \leq 125^\circ C$ , unless otherwise specified.)

Symbol	Parameter	Conditions	Min	Typ	Max	Unit
$V_{OUT}$	Output Voltage		4.8	5.0	5.2	V
		$7V \leq V_{IN} \leq 20V$ , $1mA \leq I_{OUT} \leq 100mA$ , $P_D \leq 0.75W$	<b>4.75</b>		<b>5.25</b>	
$V_{RLINE}$	Line Regulation	$7V \leq V_{IN} \leq 20V$		8	150	mV
$V_{RLOAD}$	Load Regulation	$1mA \leq I_{OUT} \leq 100mA$		10	60	mV
$I_Q$	Quiescent Current			3	5.5	mA
$\Delta I_Q$	Quiescent Current Change	$8V \leq V_{IN} \leq 20V$			<b>1.5</b>	mA
		$1mA \leq I_{OUT} \leq 40mA$			<b>0.1</b>	
PSRR	Ripple Rejection	$f=120Hz$ , $8V \leq V_{IN} \leq 18V$	<b>47</b>	62		dB
$V_{DROP}$	Dropout Voltage	$I_{OUT}=40mA$		1.7		V
		$I_{OUT}=100mA$		1.8		
$N_O$	Output Noise Voltage	$10Hz \leq f \leq 100kHz$ (Note 2)		40		$\mu V$
$\Delta V_{OUT}/\Delta T$	Output Voltage Temperature Coefficient	$I_{OUT}=5mA$		0.42		$mV/^\circ C$
$(\Delta V_{OUT}/V_{OUT})/\Delta T$				84		ppm/ $^\circ C$
$\theta_{JC}$	Thermal Resistance	TO-92		40		$^\circ C/W$
		SOT-89		28.3		
		SOIC-8		62		

Note 2: 0.01 $\mu F$  minimum load capacitance is recommended to limit high frequency noise.

**Electrical Characteristics** (Cont.)

**AS78L05C** (@  $V_{IN}=10V$ ,  $I_{OUT}=40mA$ ,  $C_{IN}=0.33\mu F$ ,  $C_{OUT}=0.1\mu F$ ,  $T_J=25^\circ C$ , **Bold** typeface applies over  $-40^\circ C \leq T_J \leq 125^\circ C$ , unless otherwise specified.)

Symbol	Parameter	Conditions	Min	Typ	Max	Unit
$V_{OUT}$	Output Voltage		5.0		5.1	V
$V_{RLINE}$	Line Regulation	$7V \leq V_{IN} \leq 20V$		8	150	mV
$V_{RLOAD}$	Load Regulation	$1mA \leq I_{OUT} \leq 100mA$		10	60	mV
$I_Q$	Quiescent Current			3	5.5	mA
$\Delta I_Q$	Quiescent Current Change	$8V \leq V_{IN} \leq 20V$			<b>1.5</b>	mA
		$1mA \leq I_{OUT} \leq 40mA$			<b>0.1</b>	
PSRR	Ripple Rejection	$f=120Hz$ , $8V \leq V_{IN} \leq 18V$	47	62		dB
$V_{DROP}$	Dropout Voltage	$I_{OUT}=40mA$		1.7		V
		$I_{OUT}=100mA$		1.8		
$N_O$	Output Noise Voltage	$10Hz \leq f \leq 100kHz$ (Note 2)		40		$\mu V$
$\frac{\Delta V_{OUT}}{\Delta T}$	Output Voltage Temperature Coefficient	$I_{OUT}=5mA$		0.42		$mV/^\circ C$
$\frac{(\Delta V_{OUT}/V_{OUT})}{\Delta T}$				84		$ppm/^\circ C$
$\theta_{JC}$	Thermal Resistance	TO-92		40		$^\circ C/W$
		SOT-89		28.3		
		SOIC-8		62		

Note 2: 0.01 $\mu F$  minimum load capacitance is recommended to limit high frequency noise.

**Electrical Characteristics** (Cont.)

**AS78L12** (@  $V_{IN}=19V$ ,  $I_{OUT}=40mA$ ,  $C_{IN}=0.33\mu F$ ,  $C_{OUT}=0.1\mu F$ ,  $T_J=25^\circ C$ , **Bold** typeface applies over  $-40^\circ C \leq T_J \leq 125^\circ C$ , unless otherwise specified.)

Symbol	Parameter	Conditions	Min	Typ	Max	Unit
$V_{OUT}$	Output Voltage		11.5	12.0	12.5	V
		$14.5V \leq V_{IN} \leq 27V$ , $1mA \leq I_{OUT} \leq 100mA$ , $P_D \leq 0.75W$	<b>11.4</b>		<b>12.6</b>	
$V_{RLINE}$	Line Regulation	$14.5V \leq V_{IN} \leq 27V$		20	250	mV
$V_{RLOAD}$	Load Regulation	$1mA \leq I_{OUT} \leq 100mA$		20	100	mV
$I_Q$	Quiescent Current			3	6	mA
$\Delta I_Q$	Quiescent Current Change	$16V \leq V_{IN} \leq 27V$			<b>1.5</b>	mA
		$1mA \leq I_{OUT} \leq 40mA$			<b>0.1</b>	
PSRR	Ripple Rejection	$f=120Hz$ , $15V \leq V_{IN} \leq 25V$	37	42		dB
$V_{DROP}$	Dropout Voltage	$I_{OUT}=40mA$		1.7		V
		$I_{OUT}=100mA$		1.8		
$N_O$	Output Noise Voltage	$10Hz \leq f \leq 100kHz$ (Note 2)		80		$\mu V$
$\Delta V_{OUT}/\Delta T$	Output Voltage Temperature Coefficient	$I_{OUT}=5mA$		1		$mV/^\circ C$
$(\Delta V_{OUT}/V_{OUT})/\Delta T$				84		ppm/ $^\circ C$
$\theta_{JC}$	Thermal Resistance	TO-92		40		$^\circ C/W$
		SOT-89		28.3		
		SOIC-8		62		

Note 2: 0.01 $\mu F$  minimum load capacitance is recommended to limit high frequency noise.

**Electrical Characteristics** (Cont.)

**AS78L15** (@  $V_{IN}=23V$ ,  $I_{OUT}=40mA$ ,  $C_{IN}=0.33\mu F$ ,  $C_{OUT}=0.1\mu F$ ,  $T_J=25^\circ C$ , **Bold** typeface applies over  $-40^\circ C \leq T_J \leq 125^\circ C$ , unless otherwise specified.)

Symbol	Parameter	Conditions	Min	Typ	Max	Unit
$V_{OUT}$	Output Voltage		14.4	15.0	15.6	V
		$17.5V \leq V_{IN} \leq 30V$ , $1mA \leq I_{OUT} \leq 100mA$ , $P_D \leq 0.75W$	<b>14.25</b>		<b>15.75</b>	
$V_{RLINE}$	Line Regulation	$17.5V \leq V_{IN} \leq 30V$		25	250	mV
$V_{RLOAD}$	Load Regulation	$1mA \leq I_{OUT} \leq 100mA$		25	150	mV
$I_Q$	Quiescent Current			3	6	mA
$\Delta I_Q$	Quiescent Current Change	$20V \leq V_{IN} \leq 30V$			<b>1.5</b>	mA
		$1mA \leq I_{OUT} \leq 40mA$			<b>0.1</b>	
PSRR	Ripple Rejection	$f=120Hz$ , $18.5V \leq V_{IN} \leq 28.5V$	34	39		dB
$V_{DROP}$	Dropout Voltage	$I_{OUT}=40mA$		1.7		V
		$I_{OUT}=100mA$		1.8		
$N_O$	Output Noise Voltage	$10Hz \leq f \leq 100kHz$ (Note 2)		90		$\mu V$
$\Delta V_{OUT}/\Delta T$	Output Voltage Temperature Coefficient	$I_{OUT}=5mA$		1.25		$mV/^\circ C$
$(\Delta V_{OUT}/V_{OUT})/\Delta T$				84		ppm/ $^\circ C$
$\theta_{JC}$	Thermal Resistance	TO-92		40		$^\circ C/W$
		SOT-89		28.3		
		SOIC-8		62		

Note 2: 0.01 $\mu F$  minimum load capacitance is recommended to limit high frequency noise.

**Performance Characteristics**

**Output Voltage vs. Input Voltage**

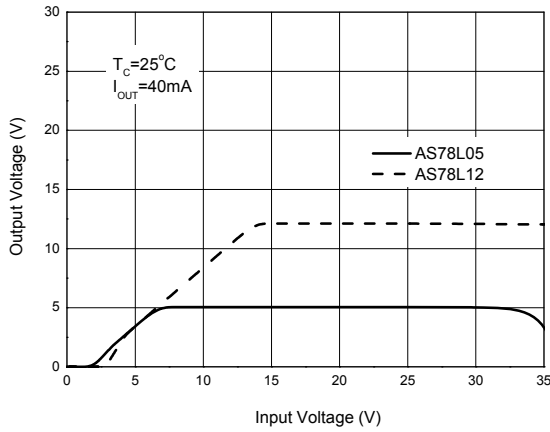

**Output Voltage vs. Case Temperature**

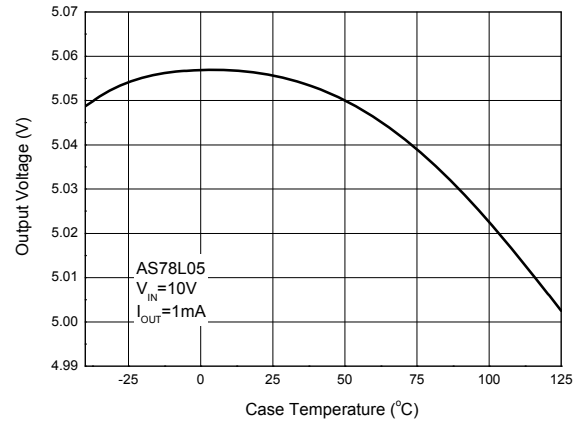

**Over Temperature Protection**

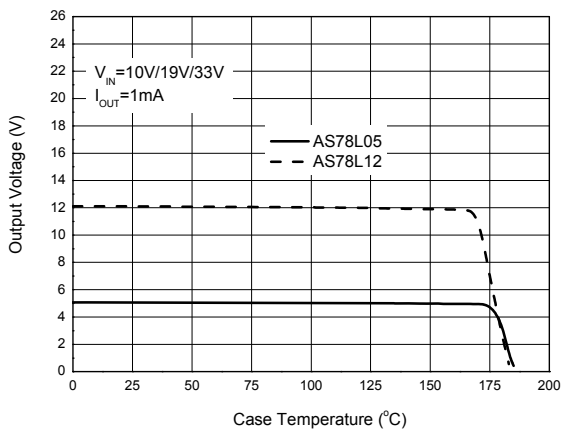

**Dropout Voltage vs. Case Temperature**

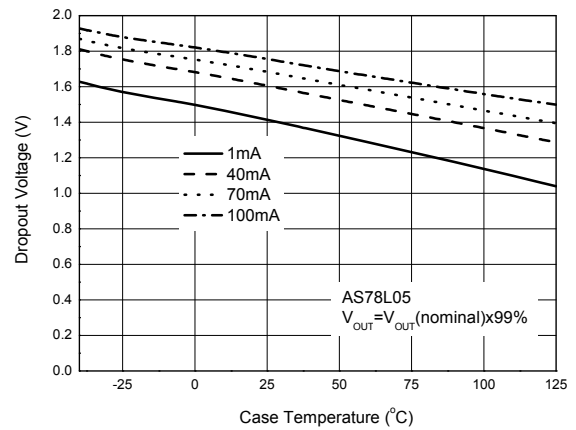

**Output Voltage vs. Output Current**

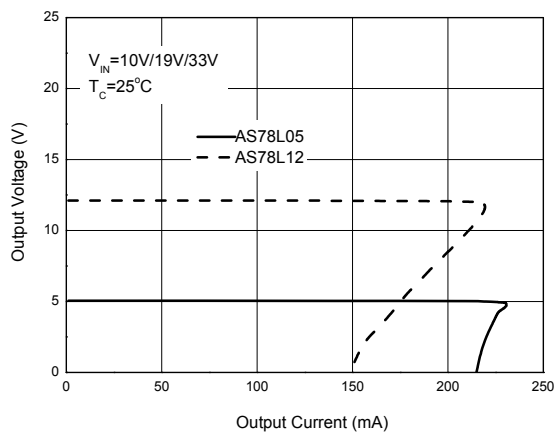

**Quiescent Current vs. Case Temperature**

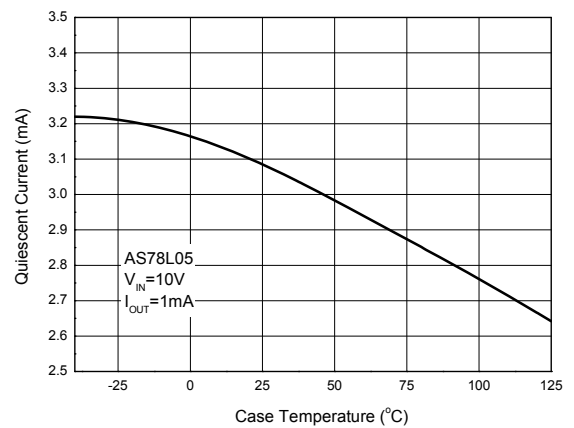



**Performance Characteristics (Cont.)**

**Power Dissipation vs. Case Temperature**

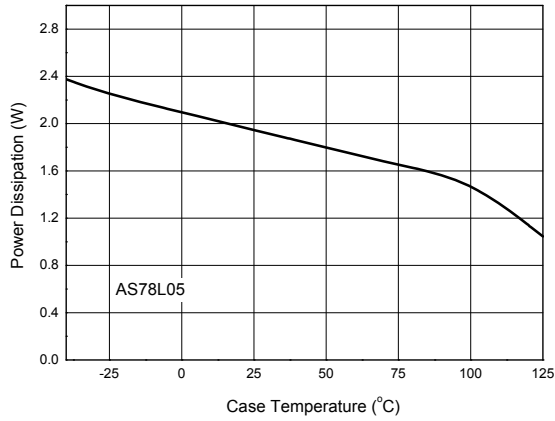

**PSRR vs. Frequency**

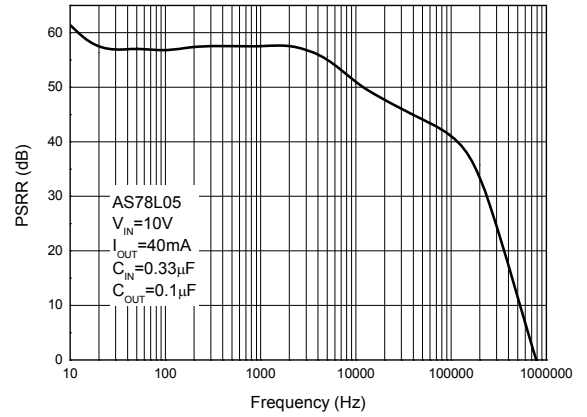

**Line Transient**  
(Conditions:  $I_{OUT}=40mA$ ,  $C_{IN}=0.33\mu F$ ,  $C_{OUT}=0.1\mu F$ )

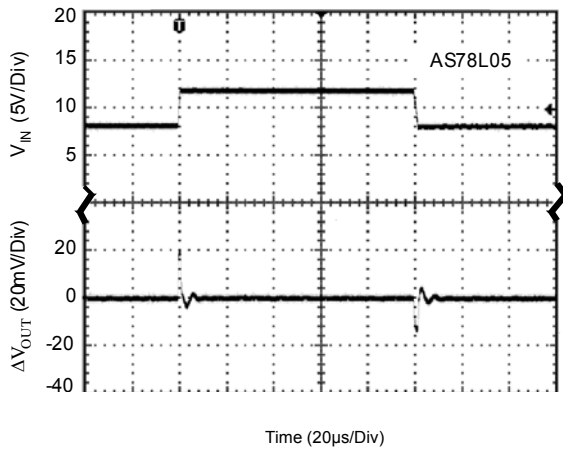

**Load Transient**  
(Conditions:  $V_{IN}=10V$ ,  $C_{IN}=0.33\mu F$ ,  $C_{OUT}=0.1\mu F$ )

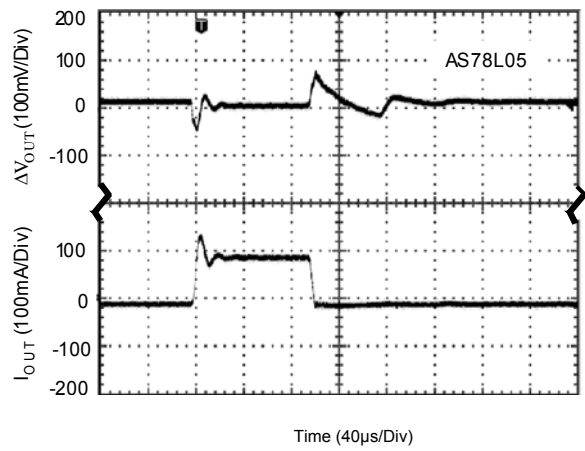

## Ordering Information

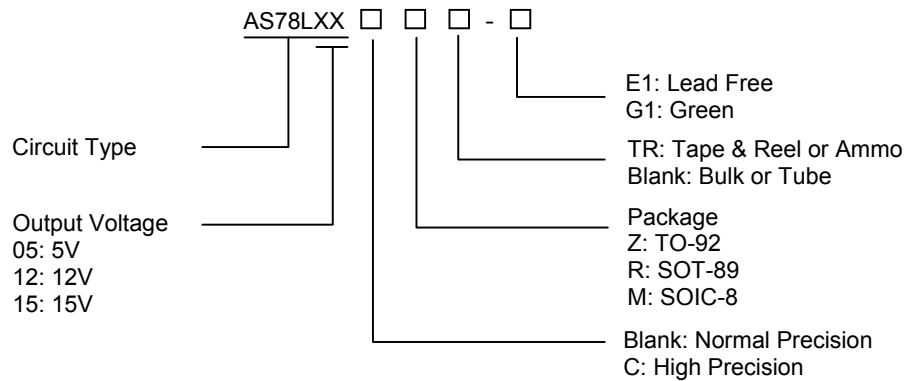

Package	Temperature Range	Part Number		Marking ID		Packing Type
		Lead Free	Green	Lead Free	Green	
TO-92	-40 to 125°C	AS78L05Z-E1	AS78L05Z-G1	AS78L05Z-E1	AS78L05Z-G1	Bulk
		AS78L05ZTR-E1	AS78L05ZTR-G1	AS78L05Z-E1	AS78L05Z-G1	Ammo
		AS78L05CZTR-E1	AS78L05CZTR-G1	AS78L05Z-E1	AS78L05Z-G1	Ammo
		AS78L12Z-E1	AS78L12Z-G1	AS78L12Z-E1	AS78L12Z-G1	Bulk
		AS78L12ZTR-E1	AS78L12ZTR-G1	AS78L12Z-E1	AS78L12Z-G1	Ammo
		AS78L15Z-E1	AS78L15Z-G1	AS78L15Z-E1	AS78L15Z-G1	Bulk
		AS78L15ZTR-E1	AS78L15ZTR-G1	AS78L15Z-E1	AS78L15Z-G1	Ammo
SOT-89	-40 to 125°C	AS78L05RTR-E1	AS78L05RTR-G1	E78E	G78E	Tape & Reel
		AS78L12RTR-E1	AS78L12RTR-G1	E78F	G78F	Tape & Reel
		AS78L15RTR-E1	AS78L15RTR-G1	E78G	G78G	Tape & Reel
SOIC-8	-40 to 125°C	AS78L05M-E1	AS78L05M-G1	AS78L05M-E1	AS78L05M-G1	Tube
		AS78L05MTR-E1	AS78L05MTR-G1	AS78L05M-E1	AS78L05M-G1	Tape & Reel
		AS78L12M-E1	AS78L12M-G1	AS78L12M-E1	AS78L12M-G1	Tube
		AS78L12MTR-E1	AS78L12MTR-G1	AS78L12M-E1	AS78L12M-G1	Tape & Reel
		AS78L15M-E1	AS78L15M-G1	AS78L15M-E1	AS78L15M-G1	Tube
		AS78L15MTR-E1	AS78L15MTR-G1	AS78L15M-E1	AS78L15M-G1	Tape & Reel

BCD Semiconductor's Pb-free products, as designated with "E1" suffix in the part number, are RoHS compliant. Products with "G1" suffix are available in green packages.

**Package Outline Dimensions** (All dimensions in mm(inch).)

**TO-92 (Bulk Packing)**

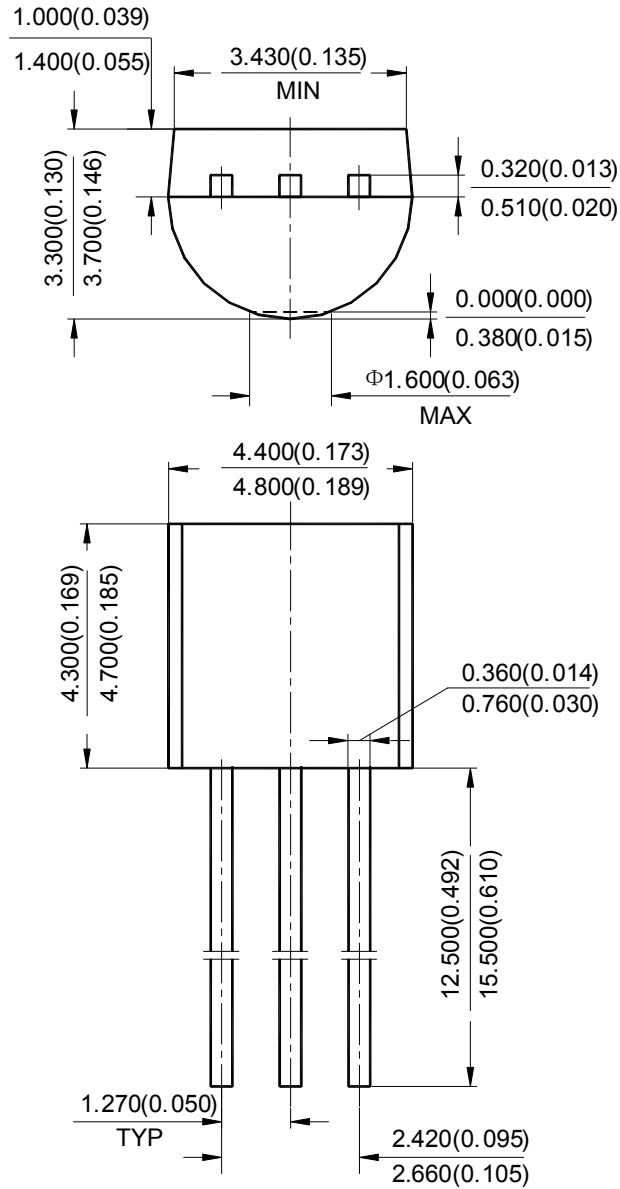



**Package Outline Dimensions** (Cont. All dimensions in mm(inch).)

**SOT-89**

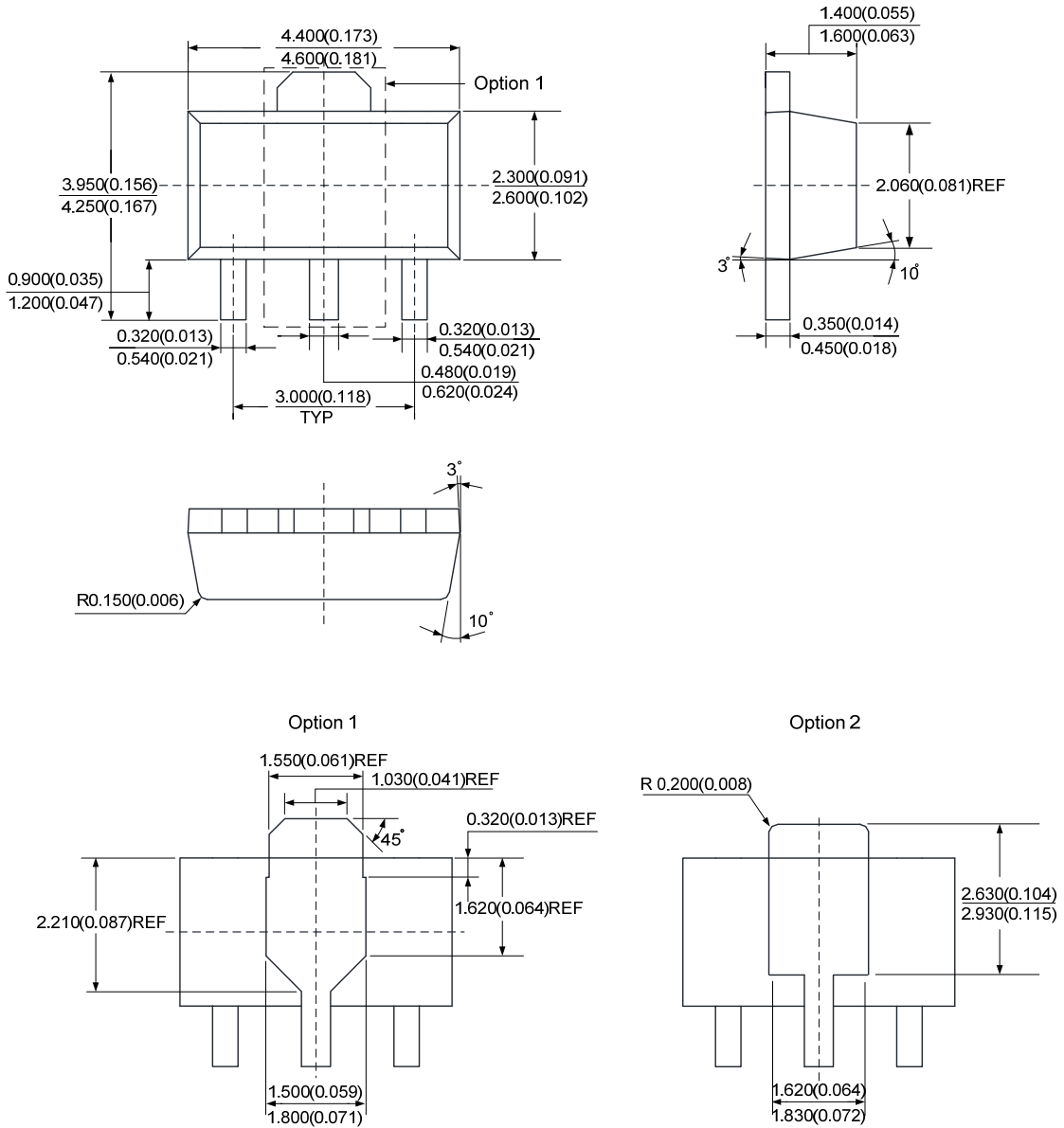

DATA SHEET

**Package Outline Dimensions** (Cont. All dimensions in mm(inch).)

**SOIC-8**

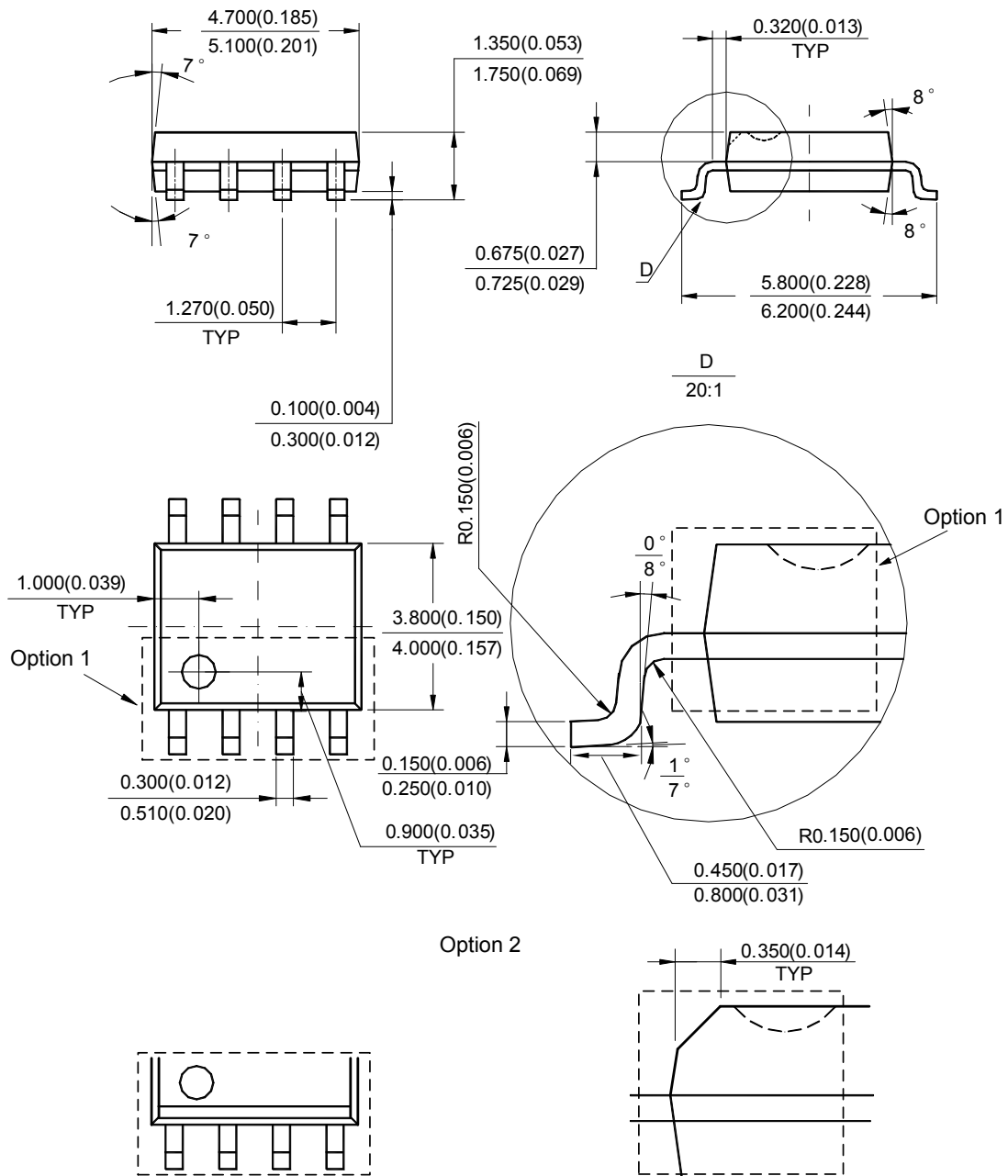

Note: Eject hole, oriented hole and mold mark is optional.

**Suggested Pad Layout**

**SOT-89**

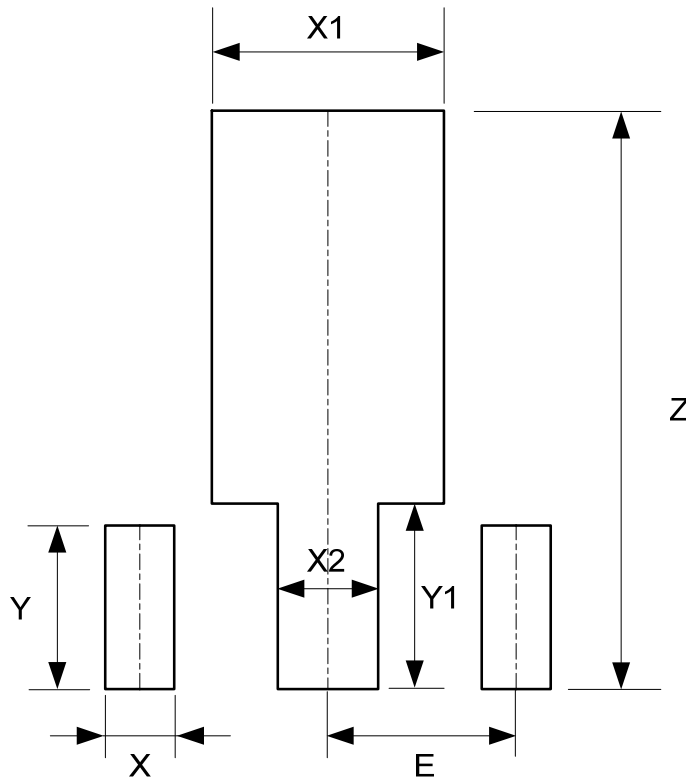

Dimensions	Z (mm)/(inch)	X (mm)/(inch)	X1 (mm)/(inch)	X2 (mm)/(inch)	Y (mm)/(inch)	Y1 (mm)/(inch)	E (mm)/(inch)
Value	4.600/0.181	0.550/0.022	1.850/0.073	0.800/0.031	1.300/0.051	1.475/0.058	1.500/0.059

**Suggested Pad Layout (Cont.)**

**SOIC-8**

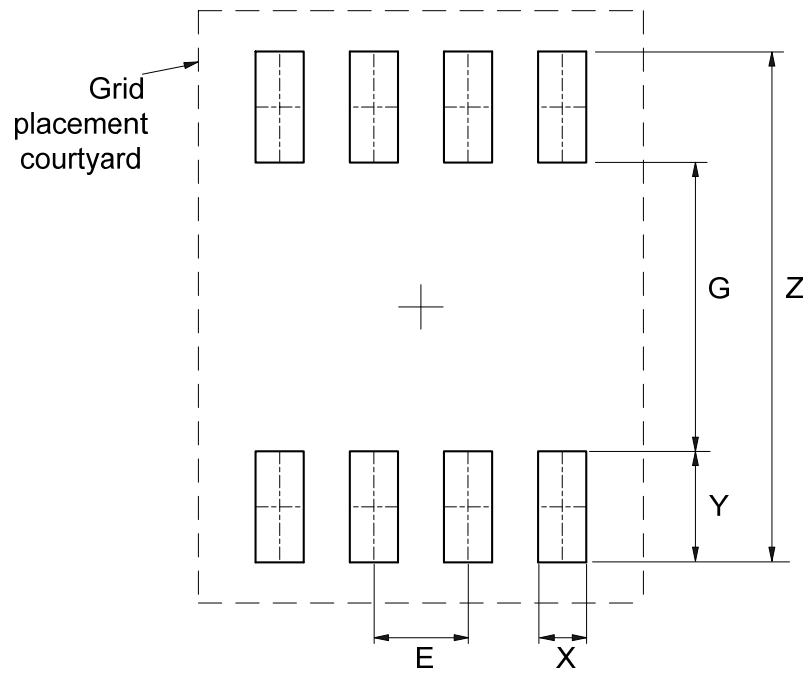

Dimensions	Z (mm)/(inch)	G (mm)/(inch)	X (mm)/(inch)	Y (mm)/(inch)	E (mm)/(inch)
Value	6.900/0.272	3.900/0.154	0.650/0.026	1.500/0.059	1.270/0.050



#### IMPORTANT NOTICE

DIODES INCORPORATED MAKES NO WARRANTY OF ANY KIND, EXPRESS OR IMPLIED, WITH REGARDS TO THIS DOCUMENT, INCLUDING, BUT NOT LIMITED TO, THE IMPLIED WARRANTIES OF MERCHANTABILITY AND FITNESS FOR A PARTICULAR PURPOSE (AND THEIR EQUIVALENTS UNDER THE LAWS OF ANY JURISDICTION).

Diodes Incorporated and its subsidiaries reserve the right to make modifications, enhancements, improvements, corrections or other changes without further notice to this document and any product described herein. Diodes Incorporated does not assume any liability arising out of the application or use of this document or any product described herein; neither does Diodes Incorporated convey any license under its patent or trademark rights, nor the rights of others. Any Customer or user of this document or products described herein in such applications shall assume all risks of such use and will agree to hold Diodes Incorporated and all the companies whose products are represented on Diodes Incorporated website, harmless against all damages.

Diodes Incorporated does not warrant or accept any liability whatsoever in respect of any products purchased through unauthorized sales channel. Should Customers purchase or use Diodes Incorporated products for any unintended or unauthorized application, Customers shall indemnify and hold Diodes Incorporated and its representatives harmless against all claims, damages, expenses, and attorney fees arising out of, directly or indirectly, any claim of personal injury or death associated with such unintended or unauthorized application.

Products described herein may be covered by one or more United States, international or foreign patents pending. Product names and markings noted herein may also be covered by one or more United States, international or foreign trademarks.

This document is written in English but may be translated into multiple languages for reference. Only the English version of this document is the final and determinative format released by Diodes Incorporated.

#### LIFE SUPPORT

Diodes Incorporated products are specifically not authorized for use as critical components in life support devices or systems without the express written approval of the Chief Executive Officer of Diodes Incorporated. As used herein:

A. Life support devices or systems are devices or systems which:

1. are intended to implant into the body, or
2. support or sustain life and whose failure to perform when properly used in accordance with instructions for use provided in the labeling can be reasonably expected to result in significant injury to the user.

B. A critical component is any component in a life support device or system whose failure to perform can be reasonably expected to cause the failure of the life support device or to affect its safety or effectiveness.

Customers represent that they have all necessary expertise in the safety and regulatory ramifications of their life support devices or systems, and acknowledge and agree that they are solely responsible for all legal, regulatory and safety-related requirements concerning their products and any use of Diodes Incorporated products in such safety-critical, life support devices or systems, notwithstanding any devices- or systems-related information or support that may be provided by Diodes Incorporated. Further, Customers must fully indemnify Diodes Incorporated and its representatives against any damages arising out of the use of Diodes Incorporated products in such safety-critical, life support devices or systems.

Copyright © 2012, Diodes Incorporated

[www.diodes.com](http://www.diodes.com)

## X-ON Electronics

Largest Supplier of Electrical and Electronic Components

*Click to view similar products for [Voltage Regulators - Switching Regulators](#) category:*

*Click to view products by [Diodes Incorporated](#) manufacturer:*

Other Similar products are found below :

[LX7186A](#) [622616F](#) [632259F](#) [FAN53610AUC33X](#) [MP2148GQD-33-P](#) [MP2374DS-LF-Z](#) [EN6310QA](#) [NCP81108MNTXG](#)  
[NCP81109BMNTXG](#) [L79M05TL-E](#) [FAN48610BUC45X](#) [R3](#) [LV5710GP-TE-L-H](#) [430464BB](#) [455605G](#) [AZ7500BMTR-E1](#) [MIC23156-](#)  
[0YML-T5](#) [MIC4930YFL-T5](#) [MP8763GLE-P](#) [KE177614](#) [418569H](#) [455596X](#) [511087D](#) [030908C](#) [063375FB](#) [067501FB](#) [099508GB](#)  
[EP5358LUA](#) [NCP81102MNTXG](#) [715715H](#) [FAN48611UC53X](#) [FAN53611AUC12X](#) [MAX809TTR](#) [MAX77596ETBC+T](#)  
[MAX77596ETBB+T](#) [MAX16905AUE/V+](#) [NCP6332CMTAATBG](#) [NCV890203MWTXG](#) [LX7176A](#) [ISL8018IRAJZ](#) [MP2162AGQH-Z](#)  
[MAX17544ATP+T](#) [MCP1623T-IMC](#) [MCP1642B-18IMC](#) [MCP1642BT-30I/MS](#) [MCP1642D-50IMC](#) [MCP1642D-50IMS](#) [MCP1642D-](#)  
[ADJIMC](#) [MC34063LBBGEVB](#) [MCP1252T-33X50IMS](#)