

ROYALOHM

SPECIFICATION FOR APPROVAL

TRANSFER ELECTRONIC

Description : Metal Film Fixed Resistors

(Resistance Range: $1\Omega \sim 9.9\Omega$)

Royalohm Part no.: MF006FFxxxxA50 (MF 0.6 W-S +/- 1% 50ppm)

Approved by

Parts corresponding to RoHS Compliant: 2005-Apr.-1

Royal Electronic Factory (Thailand) Co., Ltd.

20/1-2 Moo 2 Klong-Na, Muang

Chachoengsao 24000, Thailand

Tel: +66-38-822404-8

Fax: +66 38-981190 / 823765

E-mail Address: Export sales: Export@royalohm.com

Local sales: Local@royalohm.com

<http://www.royalohm.com>

P.O. Box 251 Klongchan, Bangkok 10240, Thailand

Approved	Checked	Prepared
Mr. Jack Lin	Ms. S. Sakultala	Ms. I. Supakhinee

Issue Date: 2006/12/22

CHANGE NOTIFICATION HISTORY

Version	Date of Version	History	Remark
1	2006/12/22	1. Resistance range: 1Ω----9.9Ω	
		2. Lead wire diameter: 0.54 ± 0.05 (Unit: mm)	

1. Scope:

This specification for approval relates to Metal Film Fixed Resistors manufactured by ROYALOHM 's specifications.

2. Type designation:

The type designation shall be in the following form :

(Ex.)	<u>MF</u>	<u>0.6 W-S</u>	<u>F</u>	<u>1Ω</u>
	Type	Power Rating	Resistance Tolerance	Nominal Resistance

3. Ratings:

Ratings shall be shown in the table 1.

Table 1

Type	MF
Rated Power	0.6W at 70 □
Max. Working Voltage	250 V
Max. Overload Voltage	500 V
Dielectric Withstanding Voltage	500 V
Rated Ambient Temp.	70 □
Operating Temp. Range	-55 □ --- +155 □
Resistance Tolerance	± 1%
Resistance Value	1Ω---9.9Ω

3.1 Power rating:

Resistors shall have a power rating based on continuous full load operation at an ambient temperature of 70 □. For temperature in excess of 70 □ , the load shall be derated as shown in the figure 1.

3.2 Voltage rating:

Resistors shall have a rated direct-current (DC) continuous working voltage or an approximate sine-wave root-mean-square (RMS) alternating-current (AC) continuous working voltage at commercial-line frequency and waveform corresponding to the power rating , as determined from the following formula :

$$RCWV = \sqrt{P \times R}$$

Were : RCWV = Rated DC or RMS AC continuous working voltage at commercial-line frequency and waveform (volt)

P = Power Rating (watt)

R = Nominal Resistance (ohm)

Metal Film Fixed Resistors

In no case shall the rated DC or RMS AC continuous working voltage be greater than the applicable maximum value

Figure 1.

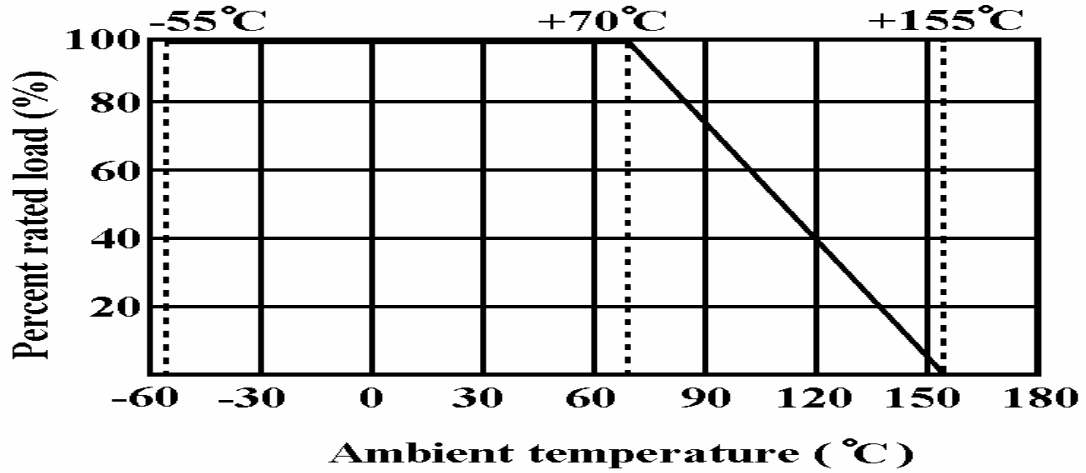

3.3 Nominal resistance :

Effective figures of nominal resistance shall be in accordance with E-96 series, and resistance tolerance shall be shown by table 1.

4. Construction :

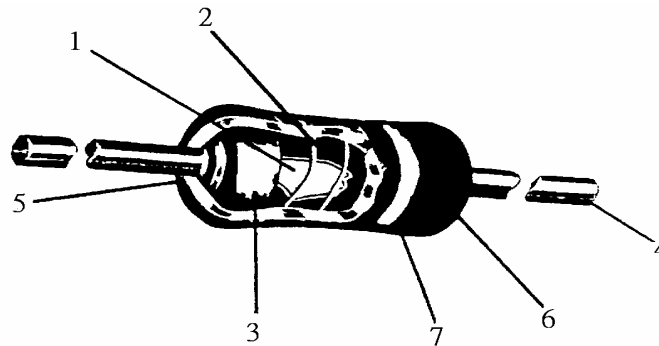

No.	Name	Material
1	Basic Body	Rod Type Ceramics
2	Resistance Film	Metal Film
3	End Cap	Steel (Tin plated iron surface)
4	Lead Wire	Annealed copper wire coated with tin
5	Joint	By Welding
6	Coating	Insulated resin (Color : Apple Green)
7	Color Code	Epoxy Resin

Metal Film Fixed Resistors

5. Characteristics :

Characteristics	Limits	Test Methods (JIS C 5201-1)
DC. Resistance	Must be within the specified tolerance	5.1 The limit of error of measuring apparatus shall not exceed allowable range or 1% of resistance tolerance
Temperature coefficient	Within the temperature coefficient specified below : ± 50 PPM/□ Max.	5.2 Natural resistance change per temp. degree centigrade $\frac{R_2 - R_1}{R_1(t_2 - t_1)} \times 10^6 \quad (\text{PPM}/\square)$ R1: Resistance value at room temperature (t1) R2: Resistance value at room temp. plus 100 □ (t2)
Short time overload	Resistance change rate is ± (0.5% + 0.05Ω) Max. with no evidence of mechanical damage	5.5 Permanent resistance change after the application of a potential of 2.5 times RCWV for 5 seconds
Dielectric withstanding voltage	No evidence of flashover mechanical damage, arcing or insulation break down	5.7 Resistors shall be clamped in the trough of a 90° metallic V-block and shall be tested at AC potential respectively specified in the table 1. for 60 + 10/ -0 seconds
Pulse overload	Resistance change rate is ± (1% + 0.05Ω) Max. with no evidence of mechanical damage	5.8 Resistance change after 10,000 cycles (1 sec. "on" , 25 secs. "off") at 4 times RCWV
Terminal strength	No evidence of mechanical damage	6.1 Direct load : Resistance to a 2.5 kgs direct load for 10 secs. in the direction of the longitudinal axis of the terminal leads Twist test : Terminal leads shall be bent through 90 ° at a point of about 6mm from the body of the resistor and shall be rotated through 360° about the original axis of the bent terminal in alternating direction for a total of 3 rotations
Resistance to soldering heat	Resistance change rate is ± (1% + 0.05Ω) Max. with no evidence of mechanical damage	6.4 Permanent resistance change when leads immersed to 3.2 to 4.8 mm from the body in 350□ ± 10 □ solder for 3 ± 0.5 seconds

Metal Film Fixed Resistors

Characteristics	Limits	Test Methods (JIS C 5201-1)															
Solderability	95 % coverage Min.	6.5 The area covered with a new, smooth, clean, shiny and continuous surface free from concentrated pinholes. Test temp. of solder : $245 \square \pm 3 \square$ Dwell time in solder : 2 ~ 3 seconds															
Resistance to solvent	No deterioration of protective coatings and markings	6.9 Specimens shall be immersed in bath of trichroethane completely for 3 mins. with ultrasonic															
Temperature cycling	Resistance change rate is $\pm (1\% + 0.05\Omega)$ Max. with no evidence of mechanical damage	7.4 Resistance change after continuous 5 cycles for duty shown below:															
		<table border="1" style="width: 100%; border-collapse: collapse;"> <thead> <tr> <th style="width: 15%;">Step</th> <th style="width: 55%;">Temperature</th> <th style="width: 30%;">Time</th> </tr> </thead> <tbody> <tr> <td style="text-align: center;">1</td> <td style="text-align: center;">$-55 \square \pm 3 \square$</td> <td style="text-align: center;">30 mins</td> </tr> <tr> <td style="text-align: center;">2</td> <td style="text-align: center;">Room temp.</td> <td style="text-align: center;">10 \square 15 mins</td> </tr> <tr> <td style="text-align: center;">3</td> <td style="text-align: center;">$+155 \square \pm 2 \square$</td> <td style="text-align: center;">30 mins</td> </tr> <tr> <td style="text-align: center;">4</td> <td style="text-align: center;">Room temp.</td> <td style="text-align: center;">10 \square 15 mins</td> </tr> </tbody> </table>	Step	Temperature	Time	1	$-55 \square \pm 3 \square$	30 mins	2	Room temp.	10 \square 15 mins	3	$+155 \square \pm 2 \square$	30 mins	4	Room temp.	10 \square 15 mins
		Step	Temperature	Time													
		1	$-55 \square \pm 3 \square$	30 mins													
		2	Room temp.	10 \square 15 mins													
3	$+155 \square \pm 2 \square$	30 mins															
4	Room temp.	10 \square 15 mins															
Load life in humidity	Resistance value	\square R/R															
	Normal type	$\pm 1.5 \%$															
Load life	Resistance value	\square R/R															
	Normal type	$\pm 1.5 \%$															
		7.9 Resistance change after 1,000 hours (1.5 hours "on", 0.5 hour "off") at RCWV in a humidity test chamber controlled at $40 \square \pm 2 \square$ and 90 to 95 % relative humidity															
		7.10 Permanent resistance change after 1,000 hours operating at RCWV with duty cycle of (1.5 hours "on", 0.5 hour "off") at $70 \square \pm 2 \square$ ambient															

Metal Film Fixed Resistors

6. Dimension :

Unit : mm

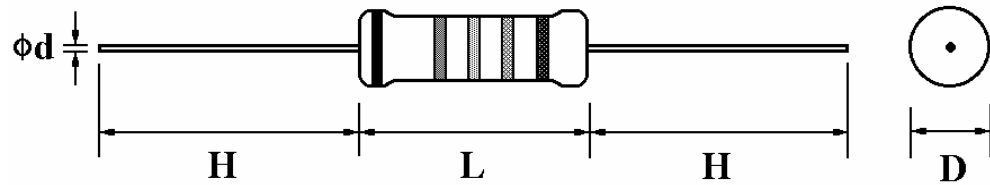

Type	Power Rating	D (Max.)	L (Max.)	$d \pm 0.05$	$H \pm 3$
MF	0.6W-S	2.5 mm	6.8 mm	0.54 mm	28 mm

Painting method:

Welding point, terminal and lead wire, is permissible to be exposed without the outer coated cover. The extent should be within 1/2 of the arc angle.

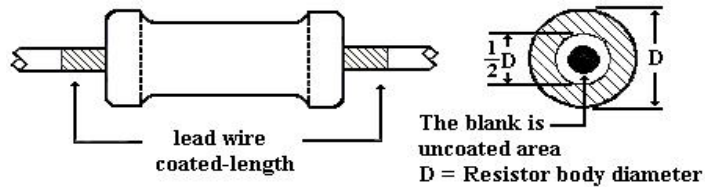

7. Marking :

7.1 Resistor :

Resistors shall be marked with color coding colors shall be in accordance with JIS C 0802

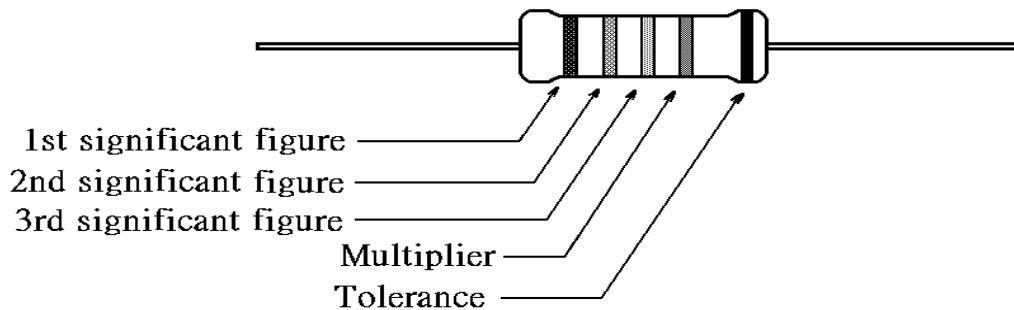

7.2 Label :

Label shall be marked with following items:

- (1) Type and style
- (2) Nominal resistance
- (3) Resistance tolerance
- (4) Quantity
- (5) Lot number
- (6) PPM

Example :

Metal Film Fixed Resistors	
Watt : 0.6W-S	Val : 1E
Q'TY : 5,000	Tol : 1%
Lot : 813478	PPM : 50
ROYALOHM	Pb Free

Metal Film Fixed Resistors

8. Packing specification :

8.1 Taping dimension :

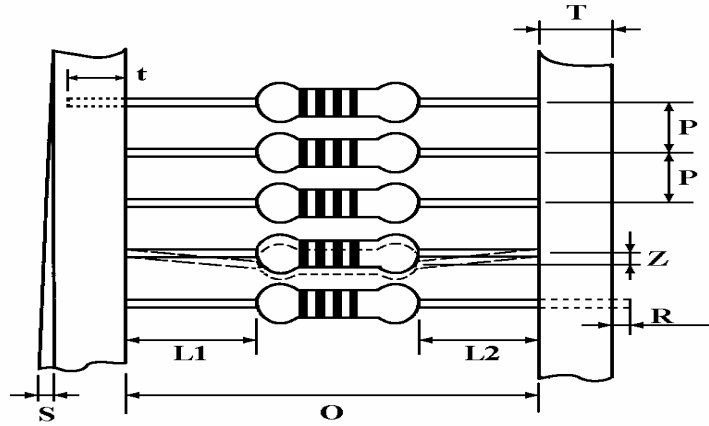

Dimensions (mm)

Type	Style	O	P	L1-L2	T	Z	R	t	S
MF-60s	PT-52	52 ± 1	5 ± 0.3	1 Max.	6 ± 1	1 Max.	0	4 ± 1	0.5 Max.

8.2 Tape in box packing :

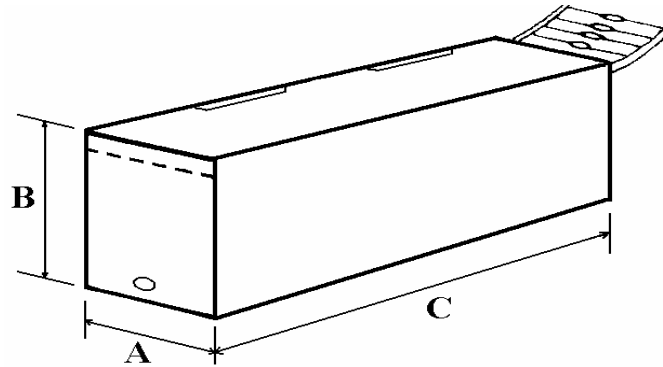

Bandoliers may also be contained in a cardboard box ("Ammopack")

Dimension (mm)

Type	Style	L (C) ± 5	W (A) ± 5	H (B) ± 5	Quantity Per Box (pcs.)
MF-60s	PT-52	250	75	96	5,000

"Ammopack" is an abbreviation of "ammunition pack"

Metal Film Fixed Resistors

8.3 Tape on reel packing :

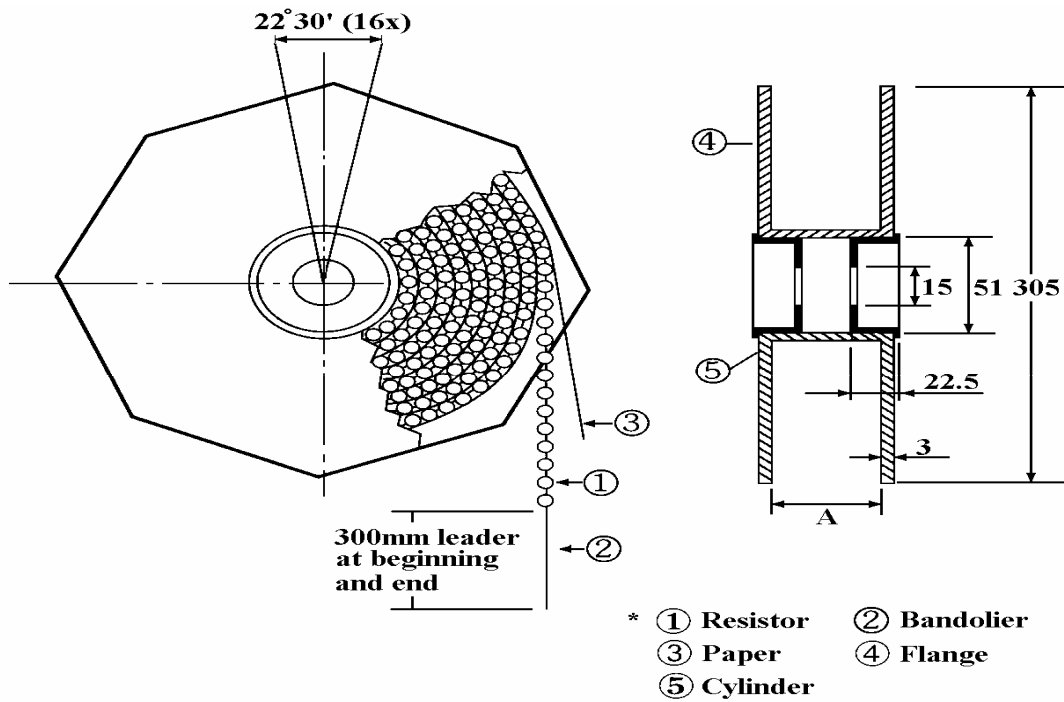

Dimension (mm) :

Type	Style	Across Flange (A)	Quantity Per Reel
MF-60s	PT-52	73 ± 2	5,000 pcs.

Part Number System

Explanation of Part Number System (Metal Film Fixed Resistors)

1 2 3 4 5 6 7 8 9 10 11 12 13 14
M F 0 0 6 F F 1 0 0 K A 5 0

Product Type:
MF = Metal Film
Fixed Resistor

Tolerance:
B = ± 0.1%
C = ± 0.25%
D = ± 0.5%
F = ± 1%
G = ± 2%
J = ± 5%

Special Feature:
0 = Standard Product
F = Non-Flame
1 = Non-Inductive Product

Resistance Value:
E-24 series: the 1st digit is "0",
the 2nd & 3rd digits are for
the significant figures of the
resistance and the 4th indicate
the number of zeros following:
"J" ~ 0.1, "K" ~ 0.01
Ex.: 4.7Ω ~ 47J, 4.7KΩ ~ 472
E--96 Series: the 1st to 3rd digits
are significant figures of
resistance and the fourth
one denotes number of zeros
following:
Ex.: 1.33KΩ = 1331

Packing Quantity:
1 = 1,000pcs
2 = 2,000pcs
3 = 3,000pcs
4 = 4,000pcs
5 = 5,000pcs
A = 500pcs
B = 2,500pcs
C = 10,000pcs
D = 20,000pcs
0 = for Bulk/Box
packing

Wattage:
Normal size: W8 = 1/8W
W4 = 1/4W
W2 = 1/2W
1W = 1W
2W = 2W
3W = 3W
Small size: S4 = 1/4W-S
S2 = 1/2W-S
06 = 0.6W-S
Extra Small size:
U2 = 1/2W-SS
04 = 0.4W-SS

PPM requirement:
B = ± 15PPM
C = ± 25PPM
F = ± 50PPM
G = ± 100PPM
J = ± 200PPM

Packing Type:
A = Tape/Box
T = Tape/Reel
B = Bulk/Box
P = Tape/Box of
PT-26mm

Addition Information:
0 = PT-52mm, NIL for PT-26mm
8 = PT-58mm
9 = PT-64mm

Sample: MF 0.6W-S +/- 1% 1Ω T/B 5,000 → MF006FF100KA50

X-ON Electronics

Largest Supplier of Electrical and Electronic Components

Click to view similar products for [Metal Film Resistors - Through Hole](#) category:

Click to view products by [Royal Ohm](#) manufacturer:

Other Similar products are found below :

[FRN25J330R](#) [FRN50J1R0S](#) [H4100RBYA](#) [H415RBZA](#) [H41K1BYA](#) [H41K5BYA](#) [H41M0BDA](#) [H420R5BCA](#) [H421R5BZA](#) [H4221RBYA](#)
[H424K3BDA](#) [H442K2BDA](#) [H45K62BZA](#) [H4634RBZA](#) [H473R2BZA](#) [H4931KBZA](#) [H8160KFDA](#) [H8274KBZA](#) [H82K0FDA](#) [H82K0FZA](#)
[H87K5DYA](#) [RLR05C1501GPB14](#) [RLR05C6201GS](#) [RLR20C3240FRB14](#) [RLR20C51R0GMB14](#) [RLR32C7R50FMB14](#) [RNC55H4642FPB14](#)
[HR01623J](#) [HR01682J](#) [270-1.69M-RC](#) [LR0204F110R](#) [LR0204F18R](#) [LR0204F20K](#) [LR0204F20R](#) [LR0204F510R](#) [LR1F121R](#) [LR1F133K](#)
[LR1F383R](#) [LR1F3K01](#) [LR1F4K75](#) [LR2F330RJIT](#) [LR2F51R](#) [LR2F910R](#) [ERX-2SZJR20E](#) [SQMR74K7J](#) [FMF-25FTF52-100K](#)
[FRN50J100RS](#) [FRN50J470RS](#) [H4100RBZA](#) [H414R3BZA](#)