



Features

- Radial Leaded Devices
- Cured, flame retardant epoxy polymer insulating material meets UL 94V-0 requirements
- Agency recognition:   
- RoHS compliant*

 The MF-RX Series is currently available, although not recommended for new designs. The higher voltage rated MF-RX/72 Series is preferred.

MF-RX Series - PTC Resettable Fuses

Electrical Characteristics

Model	V max. Volts	I max. Amps	I _{hold}	I _{trip}	Initial Resistance		1 Hour (R ₁) Post-Trip Resistance	Max. Time to Trip		Tripped Power Dissipation
			Amperes at 23 °C		Ohms at 23 °C		Ohms at 23 °C	Amperes at 23 °C	Seconds at 23 °C	Watts at 23 °C
			Hold	Trip	Min.	Max.	Max.			Typ.
MF-RX110	60	40	1.10	2.20	0.15	0.25	0.38	5.5	8.2	1.50
MF-RX135	60	40	1.35	2.70	0.12	0.19	0.30	6.75	9.6	1.70
MF-RX160	60	40	1.60	3.20	0.09	0.14	0.22	8.0	11.4	1.90
MF-RX185	60	40	1.85	3.70	0.08	0.12	0.19	9.25	12.6	2.10
MF-RX250	60	40	2.50	5.00	0.05	0.08	0.13	12.5	15.6	2.50
MF-RX300	60	40	3.00	6.00	0.04	0.06	0.10	15.0	19.8	2.80
MF-RX375	60	40	3.75	7.50	0.03	0.05	0.08	18.75	24.0	3.20

Environmental Characteristics

Operating/Storage Temperature	-40 °C to +85 °C
Maximum Device Surface Temperature in Tripped State	125 °C
Passive Aging	+85 °C, 1000 hours.....±5 % typical resistance change
Humidity Aging	+85 °C, 85 % R.H. 1000 hours.....±5 % typical resistance change
Thermal Shock	-40 °C to +85 °C, 10 times.....±10 % typical resistance change
Solvent Resistance	MIL-STD-202, Method 215.....No change
Vibration	MIL-STD-883C, Method 2007.1.....No change Condition A

Test Procedures And Requirements For Model MF-RX Series

Test	Test Conditions	Accept/Reject Criteria
Visual/Mech	Verify dimensions and materials	Per MF physical description
Resistance	In still air @ 23 °C	R _{min} ≤ R ≤ R _{max}
Time to Trip	5 times I _{hold} , V _{max} , 23 °C	T ≤ max. time to trip (seconds)
Hold Current	30 min. at I _{hold}	No trip
Trip Cycle Life	V _{max} , I _{max} , 100 cycles	No arcing or burning
Trip Endurance	V _{max} , 48 hours	No arcing or burning

UL File Number	E 174545S
CSA File Number	CA 110338
TÜV File Number	R2057213

Thermal Derating Chart - I_{hold} / I_{trip} (Amps)

Model	Ambient Operating Temperature								
	-40 °C	-20 °C	0 °C	23 °C	40 °C	50 °C	60 °C	70 °C	85 °C
MF-RX110	1.71 / 3.42	1.50 / 3.00	1.31 / 2.62	1.10 / 2.20	0.89 / 1.78	0.79 / 1.58	0.69 / 1.38	0.59 / 1.18	0.44 / 0.88
MF-RX135	2.09 / 4.18	1.84 / 3.68	1.61 / 3.22	1.35 / 2.70	1.09 / 2.18	0.97 / 1.94	0.85 / 1.70	0.73 / 1.46	0.54 / 1.08
MF-RX160	2.48 / 4.96	2.18 / 4.36	1.90 / 3.80	1.60 / 3.20	1.30 / 2.60	1.15 / 2.30	1.01 / 2.02	0.86 / 1.72	0.64 / 1.28
MF-RX185	2.87 / 5.74	2.52 / 5.04	2.20 / 4.40	1.85 / 3.70	1.50 / 3.00	1.33 / 2.66	1.17 / 2.34	1.00 / 2.00	0.74 / 1.48
MF-RX250	3.88 / 7.76	3.40 / 6.80	2.98 / 5.96	2.50 / 5.00	2.03 / 4.06	1.80 / 3.60	1.58 / 3.16	1.35 / 2.70	1.00 / 2.00
MF-RX300	4.65 / 9.30	4.08 / 8.16	3.57 / 7.14	3.00 / 6.00	2.43 / 4.86	2.16 / 4.32	1.89 / 3.78	1.62 / 3.24	1.20 / 2.40
MF-RX375	5.81 / 11.6	5.10 / 10.2	4.46 / 8.92	3.75 / 7.50	3.04 / 6.08	2.70 / 5.40	2.36 / 4.72	2.03 / 4.06	1.50 / 3.00

*RoHS Directive 2002/95/EC Jan. 27, 2003 including annex and RoHS Recast 2011/65/EU June 8, 2011. Specifications are subject to change without notice.

The device characteristics and parameters in this data sheet can and do vary in different applications and actual device performance may vary over time. Users should verify actual device performance in their specific applications.

Additional Features

- Bulk packaging, tape and reel and Ammo-Pak available on most models
- Resettable circuit protection

Applications

Almost anywhere there is a low voltage power supply, up to 60 V and a load to be protected, including:

- Security and fire alarm systems
- Loud speakers
- Power transformers

MF-RX Series - PTC Resettable Fuses

BOURNS®

Product Dimensions

Model	A Max.	B Max.	C		D Min.	E Max.	Physical Characteristics		
			Nom.	Tol. ±			Style	Lead Dia.	Material
MF-RX110	13.0 (0.512)	18.0 (0.709)	5.1 (0.201)	0.7 (0.028)	7.6 (0.299)	3.1 (0.122)	1	0.81 (0.032)	Sn/Cu
MF-RX135	14.5 (0.571)	19.6 (0.772)	5.1 (0.201)	0.7 (0.028)	7.6 (0.299)	3.1 (0.122)	1	0.81 (0.032)	Sn/Cu
MF-RX160	16.3 (0.642)	21.3 (0.839)	5.1 (0.201)	0.7 (0.028)	7.6 (0.299)	3.1 (0.122)	1	0.81 (0.032)	Sn/Cu
MF-RX185	17.8 (0.701)	22.9 (0.902)	5.1 (0.201)	0.7 (0.028)	7.6 (0.299)	3.1 (0.122)	1	0.81 (0.032)	Sn/Cu
MF-RX250	21.3 (0.839)	26.4 (1.039)	10.2 (0.402)	0.7 (0.028)	7.6 (0.299)	3.1 (0.122)	1	0.81 (0.032)	Sn/Cu
MF-RX300	24.9 (0.980)	30.0 (1.181)	10.2 (0.402)	0.7 (0.028)	7.6 (0.299)	3.1 (0.122)	1	0.81 (0.032)	Sn/Cu
MF-RX375	28.4 (1.118)	33.5 (1.319)	10.2 (0.402)	0.7 (0.028)	7.6 (0.299)	3.1 (0.122)	1	0.81 (0.032)	Sn/Cu

Packaging options:

BULK: All models = 500 pcs. per bag.

TAPE & REEL: MF-RX110 – MF-RX160 = 1500 pcs. per reel; MF-RX185 – MF-RX375 = 1000 pcs. per reel

AMMO-PACK: MF-RX110 – MF-RX160 = 1000 pcs. per reel; MF-RX185 – MF-RX375 = 500 pcs. per reel

0.81 (20AWG)

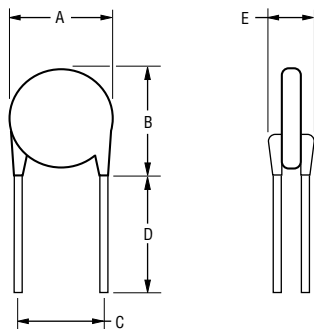

NOTE: Kinked lead option is available for board standoff. Contact factory for details.

Typical Part Marking

Represents total content. Layout may vary.

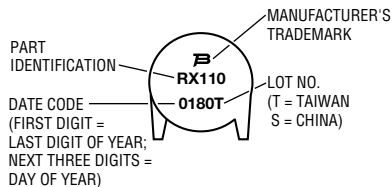

How to Order

MF - RX 110 - 0 - 99

- Multifuse® Product Designator
- Series: RX = Radial Leaded Component
- Hold Current, I_{hold} : 110-375 (1.10 Amps - 3.75 Amps)
- Packaging Options:
 - = Bulk Packaging without part number suffix option
 - 0-99 = Bulk Packaging with part number suffix option
 - 2 = Tape and Reel without part number suffix option*
 - 2-99 = Tape and Reel with part number suffix option
 - AP = Ammo-Pak*
 - 0-14 = Kinked leads where straight leads are standard
 - 0-17 = Straight leads where kinked leads are standard
- Part Number Suffix Option:
 - 99 = As of date code April 1, 2005 all MF-RX models are RoHS compliant. The suffix "-99" can be used if a new part number is required to reference the RoHS compliance.
- Examples:
 - MF-RX110 Bulk packaging
 - MF-RX110-0-99 Bulk packaging with part number suffix option
 - MF-RX110-2 Tape and reel packaging
 - MF-RX110-2-99 Tape and reel packaging with part number suffix option

Typical Time to Trip at 23 °C

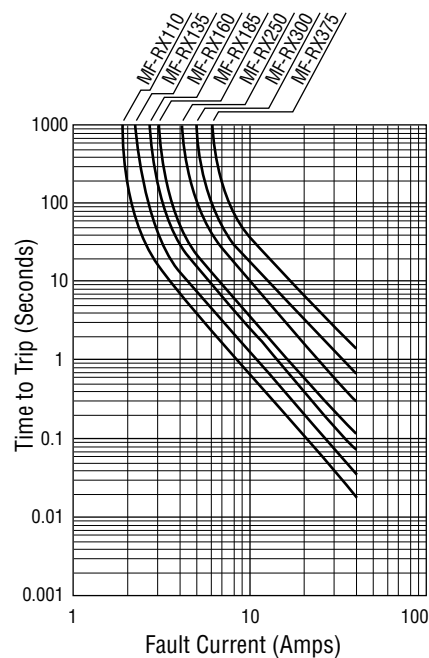

*Packaged per EIA486-B

MF-RX SERIES, REV. O, 04/14

Specifications are subject to change without notice.

The device characteristics and parameters in this data sheet can and do vary in different applications and actual device performance may vary over time. Users should verify actual device performance in their specific applications.

MF-R, MF-R/90, MF-R/600, MF-RX, & MF-RX/72 Series Tape and Reel Specifications

BOURNS®

Devices taped using EIA468-B/IEC286-2 standards. See table below and Figures 1 and 2 for details.

Dimension Description	IEC Mark	EIA Mark	Dimensions	
			Dimensions	Tolerance
Carrier tape width	W	W	$\frac{18}{(.709)}$	$\frac{-0.5/+1.0}{(-0.02/+0.039)}$
Hold down tape width	W_0	W_4	$\frac{11}{(.433)}$	min.
Hold down tape			No protrusion	
Top distance between tape edges	W_2	W_6	$\frac{3}{(.118)}$	max.
Sprocket hole position	W_1	W_5	$\frac{9}{(.354)}$	$\frac{-0.5/+0.75}{(-0.02/+0.03)}$
Sprocket hole diameter	D_0	D_0	$\frac{4}{(.157)}$	$\frac{\pm 0.2}{(\pm .0078)}$
Abscissa to plane (straight lead)	H	H	$\frac{18.5}{(.728)}$	$\frac{\pm 3.0}{(\pm .118)}$
Abscissa to plane (kinked lead)	H_0	H_0	$\frac{16}{(.63)}$	$\frac{\pm 0.5}{(\pm .02)}$
Abscissa to top (straight lead)	H_1	H_1	$\frac{38.0}{(1.496)}$	max.
Abscissa to top (kinked lead)	H_1	H_1	$\frac{32.2}{(1.268)}$	max.
Overall width w/lead protrusion (straight lead)		C_1	$\frac{55.0}{(2.165)}$	max.
Overall width w/lead protrusion (kinked lead)		C_1	$\frac{43.2}{(1.7)}$	max.
Overall width w/o lead protrusion (straight lead)		C_2	$\frac{54.0}{(2.126)}$	max.
Overall width w/o lead protrusion (kinked lead)		C_2	$\frac{42.5}{(1.673)}$	max.
Lead protrusion	l_1	L_1	$\frac{1.0}{(.039)}$	max.
Protrusion of cutout	L	L	$\frac{11}{(.433)}$	max.
Protrusion beyond hold-down tape	l_2	l_2	Not specified	
Sprocket hole pitch	P_0	P_0	$\frac{12.7}{(0.5)}$	$\frac{\pm 0.3}{(\pm .012)}$
Pitch tolerance			20 consecutive	$\frac{\pm 1}{(\pm .039)}$
Device pitch: MF-R005–MF-R160, MF-R/90, MF-RX110/72–MF-RX185/72			$\frac{12.7}{(0.5)}$	$\frac{\pm 0.3}{(\pm .012)}$
Device pitch: MF-R185–MF-R400, MF-RX110–MF-RX375 MF-R/600, MF-RX250/72–MF-RX375/72			$\frac{25.4}{(1.0)}$	$\frac{\pm 0.6}{(\pm .024)}$
Tape thickness	t	t	$\frac{0.9}{(.035)}$	max.
Tape thickness with splice: MF-R010–MF-R160, MF-RX110/72–MF-RX185/72		t_1	$\frac{1.5}{(.059)}$	max.
Tape thickness with splice: MF-R250–MF-R1100, MF-RX110–MF-RX375, MF-R/90, MF-RX250/72–MF-RX375/72		t_1	$\frac{2.3}{(.091)}$	max.
Splice sprocket hole alignment			0	$\frac{\pm 0.3}{(\pm .012)}$
Body lateral deviation	Δ_h	Δ_h	0	$\frac{\pm 1.0}{(\pm .039)}$
Body tape plane deviation	Δ_p	Δ_p	0	$\frac{\pm 1.3}{(\pm .051)}$

DIMENSIONS: $\frac{\text{MM}}{\text{(INCHES)}}$

Specifications are subject to change without notice.

The device characteristics and parameters in this data sheet can and do vary in different applications and actual device performance may vary over time. Users should verify actual device performance in their specific applications.

MF-R, MF-R/90, MF-R/600, MF-RX, & MF-RX/72 Series Tape and Reel Specifications

BOURNS®

Dimension Description	IEC Mark	EIA Mark	Dimensions	
			Dimensions	Tolerance
Lead spacing: MF-R, MF-R/90, MF-R/600, MF-RX, MF-RX/72	<i>F</i>	<i>F</i>	$\frac{5.08}{(0.2)}$	$\frac{\pm 0.2}{(\pm 0.008)}$
Reel width	<i>w</i>	<i>W₂</i>	$\frac{56.0}{(2.205)}$	max.
Reel diameter	<i>d</i>	<i>a</i>	$\frac{370.0}{(14.57)}$	max.
Space between flanges less device	<i>W₁</i>	<i>h</i>	$\frac{4.75}{(.187)}$	$\frac{\pm 3.25}{(\pm .128)}$
Arbor hole diameter	<i>f</i>	<i>c</i>	$\frac{26.0}{(1.024)}$	$\frac{\pm 12.0}{(\pm .472)}$
Core diameter: MF-R, MF-RX, MF-R/90	<i>h</i>	<i>n</i>	$\frac{80}{(3.15)}$	max.
Core diameter: MF-R/600	<i>h</i>	<i>n</i>	$\frac{91}{(3.58)}$	max.
Box: MF-R, MF-RX, MF-R/90			$\frac{62}{(2.44)}$ $\frac{355}{(14.0)}$ $\frac{345}{(13.6)}$	nom.
Box: MF-R/600			$\frac{64}{(2.52)}$ $\frac{372}{(14.6)}$ $\frac{362}{(14.25)}$	max.
Consecutive missing places: MF-R, MF-RX, MF-R/90			3	max.
Consecutive missing places: MF-R/600			none	
Empty places per reel: MF-R, MF-RX, MF-R/90			Not specified	
Empty places per reel: MF-R/600			0.1 %	

**Taped Component Dimensions -
Figure 1**

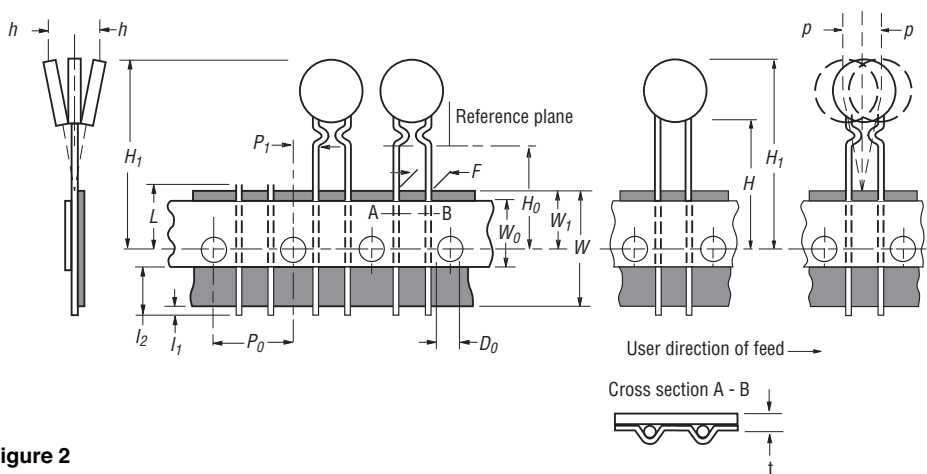

Reel Dimensions - Figure 2

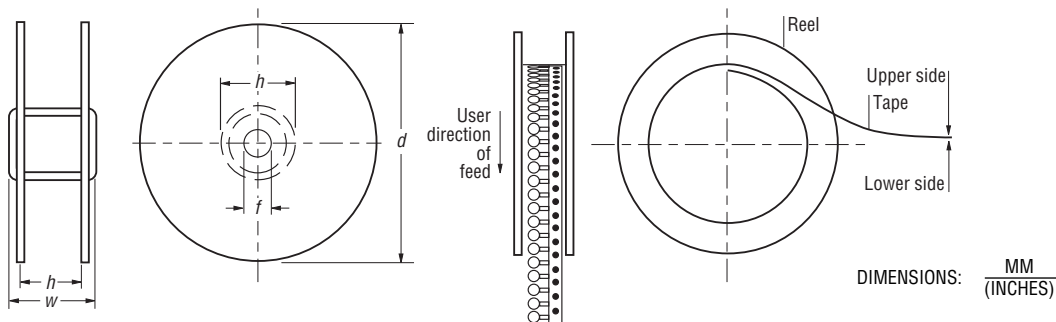

Specifications are subject to change without notice.
The device characteristics and parameters in this data sheet can and do vary in different applications and actual device performance may vary over time.
Users should verify actual device performance in their specific applications.

X-ON Electronics

Largest Supplier of Electrical and Electronic Components

Click to view similar products for [Resettable Fuses - PPTC category](#):

Click to view products by [Bourns manufacturer](#):

Other Similar products are found below :

[0001.1010.G](#) [D38999/20WG39JN](#) [F02B250V1-4AS](#) [9728214S-2\(621\)](#) [RF0627-000](#) [RF2534-000](#) [ASMD185-2](#) [EN2997S61212AN](#)
[EN2997SE61203AN](#) [BK-ABC-V-5-R](#) [LR4-550RAF](#) [SMD125-2](#) [F60C500V20AS](#) [RF0078-000](#) [RF1548-000](#) [RF1973-000](#) [RF2171-000](#)
[RF2531-000](#) [RF2533-000](#) [RF2550-000](#) [TR600-150Q-B-0.5-0.130](#) [BK-AGX-20](#) [5E4795/04-1502](#) [EN2997S61212MN](#) [EN2997SE61203MN](#)
[EN2997SE61212AN](#) [EN2997SE61212MN](#) [BK1/S505-1.25-R](#) [TR-3216FF20-R](#) [TRF250-080T-B-1.0-0.125](#) [JT06RT1832BN014](#) [S-3-2-10](#)
[SMD100-2](#) [FRN-R-5-6-10](#) [FRS-R-3-2-10](#) [LP-CC-2-1-2](#) [LPS-RK-3-2-10SP](#) [BK-AGC-1-8-R](#) [BK-AGC-2-10-R](#) [BK-AGC-7-1-2](#) [BK-GDC-](#)
[500MA](#) [BK-MDL-1-6-10-R](#) [BK-SFE-4](#) [BK-ABC-1-R](#) [BK-C518-250-R](#) [BK-GDB-2A](#) [BK-MDL-1-8-R](#) [BK-MDL-6](#) [BK-AGC-5-R](#) [BK-ATC-](#)