

Cautions and Warnings

Please be noted that this spec is only for reference if you have projects designed with the product number listed in. If you are looking for new project design-in, please find BDCD Series specification/datasheet on Chilisin website. Or you may find our sales contact for more information on old part number at your convenience. Appreciated your attention and understanding.

Note: Please be sure to request approval specifications that provide further details of the products. Kindly note that the content of these specifications are subject to change or may be discontinued without prior notice. This product may not be designed/used in medical or high risk applications without Chilisin approval. Please contact our sales department before ordering.

MHCD Series

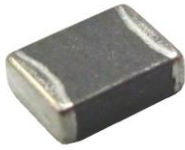

MHCD Series provides high current in compact package size with magnetically shielded construction. This power inductor is an excellent power solution for space-limited devices.

Features

- RoHS, Halogen Free and REACH Compliance
- Monolithic, magnetically shielded
- Capable for large current

Applications

- Smartphones, tablets and wearable devices
- HDD, SSD and PC peripheral devices
- DSC, camcoders
- PND
- DC/DC converters

Product Identification

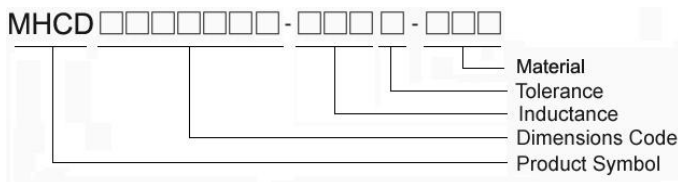

Shape and Dimensions

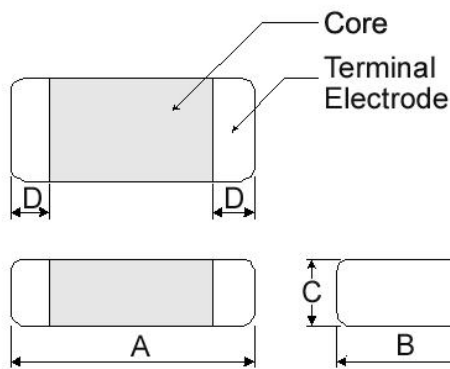

Dimensions in mm

| TYPE | A | B | C | D |
|--------|---------|---------|--------|---------|
| 201610 | 2.0±0.2 | 1.6±0.2 | 1.0Max | 0.5±0.3 |
| 201612 | 2.0±0.2 | 1.6±0.2 | 1.2Max | 0.5±0.3 |
| 252010 | 2.5±0.2 | 2.0±0.2 | 1.0Max | 0.6±0.3 |
| 252012 | 2.5±0.2 | 2.0±0.2 | 1.2Max | 0.6±0.3 |
| 322510 | 3.2±0.3 | 2.5±0.3 | 1.0Max | 0.5±0.3 |
| 322512 | 3.2±0.3 | 2.5±0.3 | 1.2Max | 0.5±0.3 |

Recommended Pattern

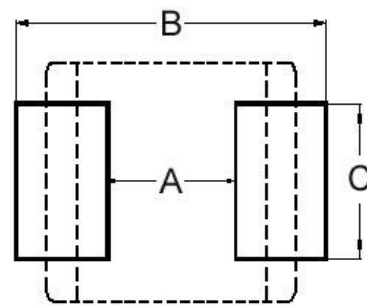

Dimensions in mm

| TYPE | A | B | C |
|--------|-----|-----|-----|
| 201610 | 0.7 | 2.3 | 1.8 |
| 201612 | 0.7 | 2.3 | 1.8 |
| 252010 | 1.2 | 2.8 | 2.3 |
| 252012 | 1.2 | 2.8 | 2.3 |
| 322510 | 1.7 | 3.5 | 2.8 |
| 322512 | 1.7 | 3.5 | 2.8 |

Molding Power Inductors – MHCD Series

Electrical Characteristics

| Part Number | Inductance (uH) | Tolerance (±%) | Test Frequency (MHz) | RDC(mΩ) Max(Typ.) | Isat(A) Max(Typ.) | Irms(A) Max(Typ.) |
|----------------------|-----------------|----------------|----------------------|-------------------|-------------------|-------------------|
| MHCD201610A-R24M-A8S | 0.24 | 20 | 2 | 40(28) | 4.2(6.0) | 4.0(4.5) |
| MHCD201610A-R33M-A8S | 0.33 | 20 | 2 | 48(40) | 4.0(5.5) | 3.5(3.8) |
| MHCD201610A-R47M-A8S | 0.47 | 20 | 2 | 54(44) | 3.2(5.0) | 3.0(3.6) |
| MHCD201610A-R56M-A8S | 0.56 | 20 | 2 | 59(46) | 2.8(4.6) | 2.8(3.3) |
| MHCD201610A-R68M-A8S | 0.68 | 20 | 2 | 72(55) | 2.7(4.2) | 2.4(3.0) |
| MHCD201610A-1R0M-A8S | 1.0 | 20 | 2 | 96(81) | 2.2(3.4) | 2.0(2.3) |
| MHCD201610A-1R5M-A8S | 1.5 | 20 | 2 | 150(122) | 2.1(2.8) | 1.6(2.0) |
| MHCD201610A-2R2M-A8S | 2.2 | 20 | 2 | 204(170) | 2.0(2.4) | 1.3(1.6) |

Note: When ordering, please specify tolerance code. Tolerance: M=±20%

- Operating temperature range - 40°C ~ 125°C(Including self - temperature rise)
- Isat for Inductance drop 30% from its value without current
- I rms for a 40°C temperature rise from 25°C ambient with current
- Absolute maximum voltage 25VDC
- Measure Equipment :
 L : Agilent E4991/HP4286A+16197A (or equivalent), 2MHz 0.2V
 RDC : CHEN HWA502BC/HP4338B (or equivalent)
 Isat : Agilent E4980A+HP42841A (or equivalent)
 I rms : Agilent 6641 SYSTEM DC POWER SUPPLY (or equivalent)

Test Instruments : E4991A Impedance / Material Analyzer

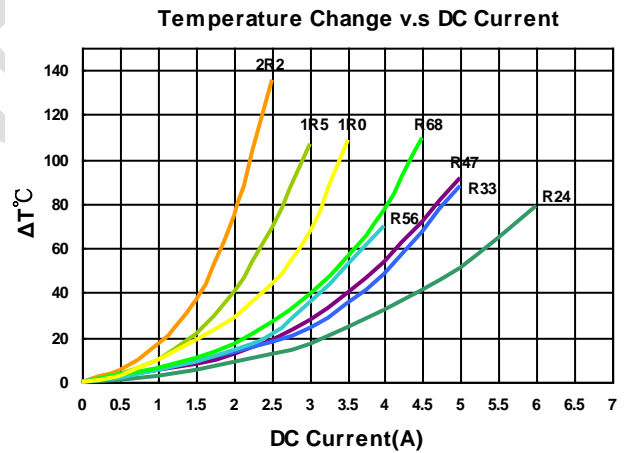
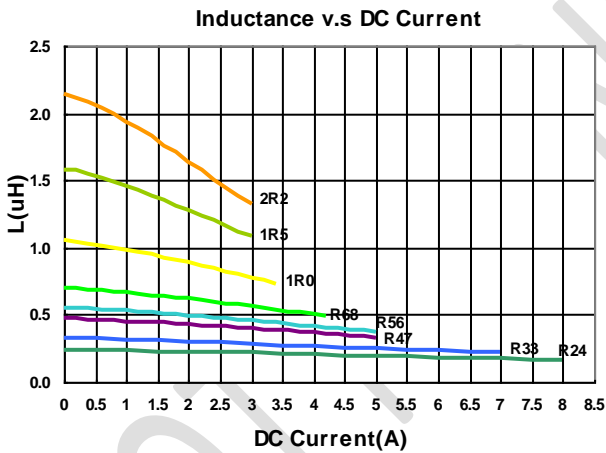

Molding Power Inductors – MHCD Series

Electrical Characteristics

| Part Number | Inductance (uH) | Tolerance (±%) | Test Frequency (MHz) | RDC(mΩ) Max(Typ.) | Isat(A) Max(Typ.) | Irms(A) Max(Typ.) |
|----------------------|-----------------|----------------|----------------------|-------------------|-------------------|-------------------|
| MHCD201610B-R24M-A8L | 0.24 | 20 | 2 | 30(23) | 5.0(6.0) | 3.8(4.4) |
| MHCD201610B-R47M-A8L | 0.47 | 20 | 2 | 41(34) | 4.0(4.5) | 2.9(3.3) |
| MHCD201610B-R68M-A8L | 0.68 | 20 | 2 | 53(44) | 3.3(3.6) | 2.5(2.9) |
| MHCD201610B-1R0M-A8L | 1.0 | 20 | 2 | 72(60) | 2.8(3.2) | 2.2(2.5) |
| MHCD201610B-2R2M-A8L | 2.2 | 20 | 2 | 170(142) | 1.8(2.1) | 1.5(1.7) |

Note: When ordering, please specify tolerance code. Tolerance: M=±20%

- Operating temperature range - 40°C ~ 125°C(Including self - temperature rise)
- Isat for Inductance drop 30% from its value without current
- I rms for a 40°C temperature rise from 25°C ambient with current
- Absolute maximum voltage 25VDC
- Measure Equipment :
 L : Agilent E4991/HP4286A+16197A (or equivalent), 2MHz 0.2V
 RDC : CHEN HWA502BC/HP4338B (or equivalent)
 Isat : Agilent E4980A+HP42841A (or equivalent)
 I rms : Agilent 6641 SYSTEM DC POWER SUPPLY (or equivalent)

Test Instruments : E4991A Impedance / Material Analyzer

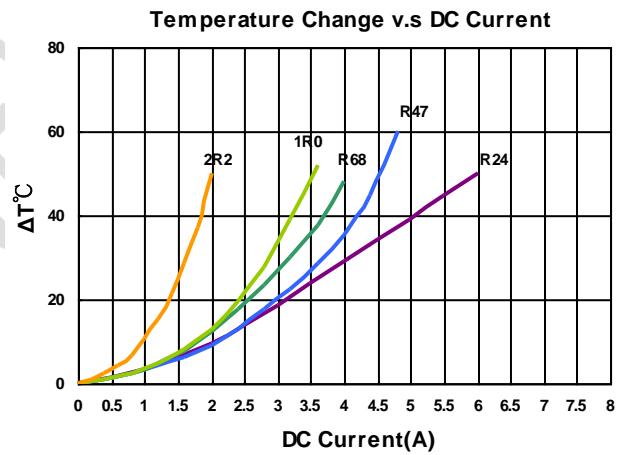
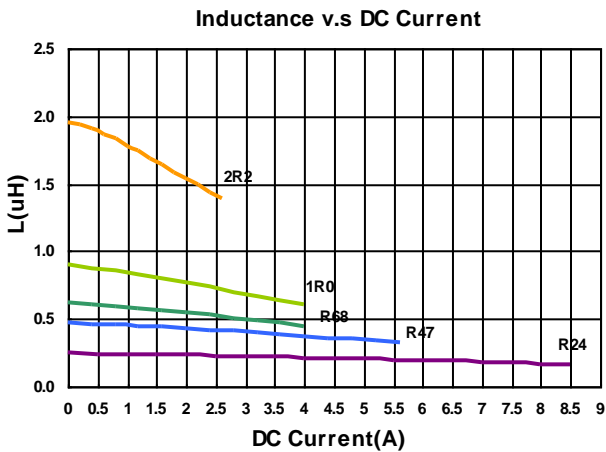

Molding Power Inductors – MHCD Series

Electrical Characteristics

| Part Number | Inductance (uH) | Tolerance (±%) | Test Frequency (MHz) | RDC(mΩ) Max(Typ.) | Isat(A) Max(Typ.) | Irms(A) Max(Typ.) |
|----------------------|-----------------|----------------|----------------------|-------------------|-------------------|-------------------|
| MHCD201612A-R24M-A8S | 0.24 | 20 | 2 | 35(25) | 5.5(6.5) | 4.2(4.8) |
| MHCD201612A-R47M-A8S | 0.47 | 20 | 2 | 52(40) | 3.8(5.1) | 3.2(3.8) |
| MHCD201612A-R68M-A8S | 0.68 | 20 | 2 | 70(53) | 3.3(4.8) | 2.6(3.2) |
| MHCD201612A-1R0M-A8S | 1.0 | 20 | 2 | 82(67) | 3.1(3.9) | 2.3(2.7) |
| MHCD201612A-1R5M-A8S | 1.5 | 20 | 2 | 120(95) | 2.6(3.2) | 2.2(2.6) |
| MHCD201612A-2R2M-A8S | 2.2 | 20 | 2 | 195(165) | 2.0(2.6) | 1.3(1.7) |

Note: When ordering, please specify tolerance code. Tolerance: M=±20%

- Operating temperature range - 40°C ~ 125°C(Including self - temperature rise)
- Isat for Inductance drop 30% from its value without current
- I rms for a 40°C temperature rise from 25°C ambient with current
- Absolute maximum voltage 25VDC
- Measure Equipment :
 L : Agilent E4991/HP4286A+16197A (or equivalent), 2MHz 0.2V
 RDC : CHEN HWA502BC/HP4338B (or equivalent)
 Isat : Agilent E4980A+HP42841A (or equivalent)
 I rms : Agilent 6641 SYSTEM DC POWER SUPPLY (or equivalent)

Test Instruments : E4991A Impedance / Material Analyzer

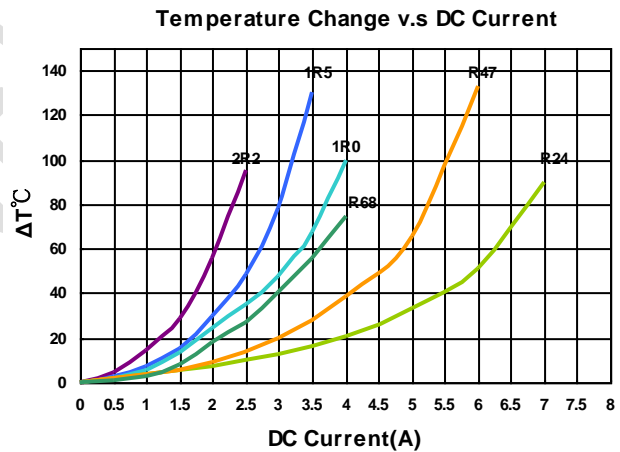
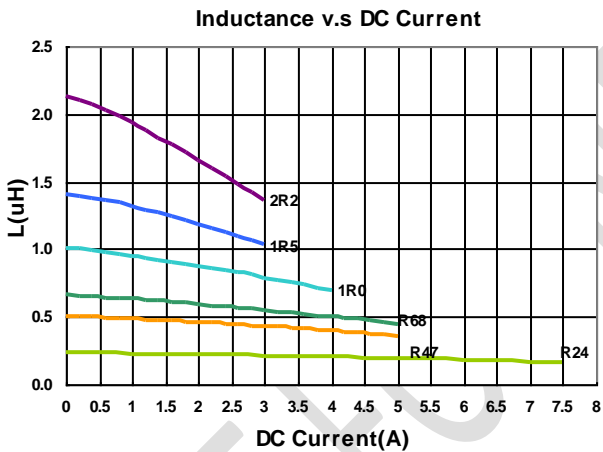

Molding Power Inductors – MHCD Series

Electrical Characteristics

| Part Number | Inductance (uH) | Tolerance (±%) | Test Frequency (MHz) | RDC(mΩ) Max(Typ.) | Isat(A) Max(Typ.) | Irms(A) Max(Typ.) |
|----------------------|-----------------|----------------|----------------------|-------------------|-------------------|-------------------|
| MHCD252010A-R24M-A8S | 0.24 | 20 | 2 | 40(24) | 7.5(9.5) | 4.5(5.0) |
| MHCD252010A-R47M-A8S | 0.47 | 20 | 2 | 46(36) | 5.2(6.5) | 3.1(3.6) |
| MHCD252010A-R68M-A8S | 0.68 | 20 | 2 | 65(49) | 3.8(5.0) | 2.9(3.3) |
| MHCD252010A-1R0M-A8S | 1.0 | 20 | 2 | 78(60) | 3.4(4.3) | 2.5(3.0) |
| MHCD252010A-1R5M-A8S | 1.5 | 20 | 2 | 105(82) | 3.2(4.0) | 2.2(2.9) |
| MHCD252010A-2R2M-A8S | 2.2 | 20 | 2 | 156(130) | 2.6(3.2) | 1.4(1.8) |

Note: When ordering, please specify tolerance code. Tolerance: M=±20%

- Operating temperature range - 40°C ~ 125°C(Including self - temperature rise)
- Isat for Inductance drop 30% from its value without current
- I rms for a 40°C temperature rise from 25°C ambient with current
- Absolute maximum voltage 25VDC
- Measure Equipment :
 L : Agilent E4991/HP4286A+16197A (or equivalent), 2MHz 0.2V
 RDC : CHEN HWA502BC/HP4338B (or equivalent)
 Isat : Agilent E4980A+HP42841A (or equivalent)
 I rms : Agilent 6641 SYSTEM DC POWER SUPPLY (or equivalent)

Test Instruments : E4991A Impedance / Material Analyzer

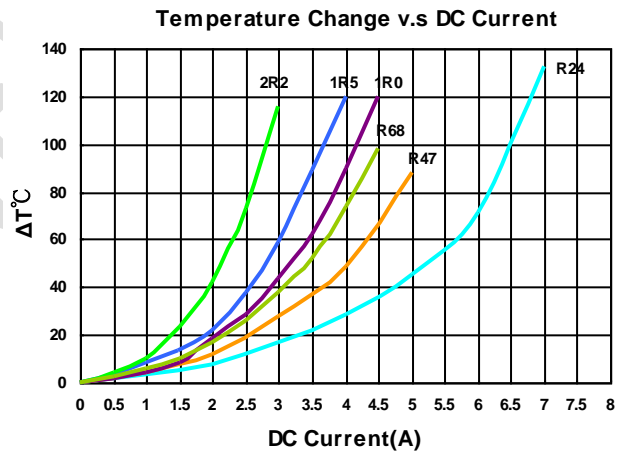
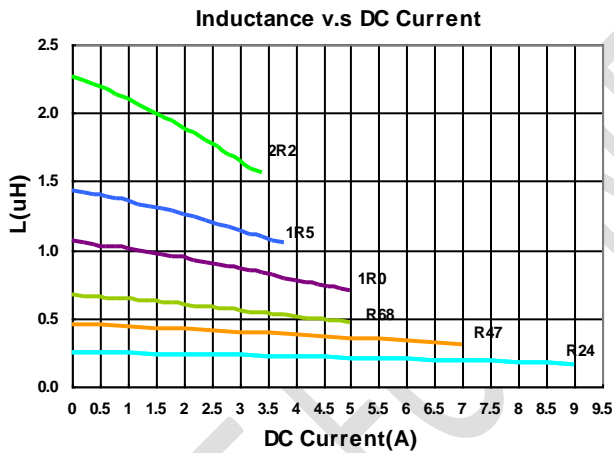

Molding Power Inductors – MHCD Series

Electrical Characteristics

| Part Number | Inductance (uH) | Tolerance (±%) | Test Frequency (MHz) | RDC(mΩ) Max(Typ.) | Isat(A) Max(Typ.) | Irms(A) Max(Typ.) |
|----------------------|-----------------|----------------|----------------------|-------------------|-------------------|-------------------|
| MHCD252010B-R33M-A8L | 0.33 | 20 | 2 | 31(25) | 5.0(6.0) | 3.8(4.4) |
| MHCD252010B-R47M-A8L | 0.47 | 20 | 2 | 35(29) | 4.2(4.7) | 3.4(3.9) |
| MHCD252010B-R68M-A8L | 0.68 | 20 | 2 | 48(40) | 3.7(4.0) | 3.0(3.5) |
| MHCD252010B-1R0M-A8L | 1.0 | 20 | 2 | 65(54) | 3.2(3.6) | 2.6(3.0) |
| MHCD252010B-1R5M-A8L | 1.5 | 20 | 2 | 94(78) | 2.9(3.3) | 2.1(2.4) |
| MHCD252010B-2R2M-A8L | 2.2 | 20 | 2 | 120(100) | 2.3(2.7) | 1.8(2.1) |

Note: When ordering, please specify tolerance code. Tolerance: M=±20%

- Operating temperature range - 40°C ~ 125°C(Including self - temperature rise)
- Isat for Inductance drop 30% from its value without current
- I rms for a 40°C temperature rise from 25°C ambient with current
- Absolute maximum voltage 25VDC
- Measure Equipment :
 L : Agilent E4991/HP4286A+16197A (or equivalent), 2MHz 0.2V
 RDC : CHEN HWA502BC/HP4338B (or equivalent)
 Isat : Agilent E4980A+HP42841A (or equivalent)
 I rms : Agilent 6641 SYSTEM DC POWER SUPPLY (or equivalent)

Test Instruments : E4991A Impedance / Material Analyzer

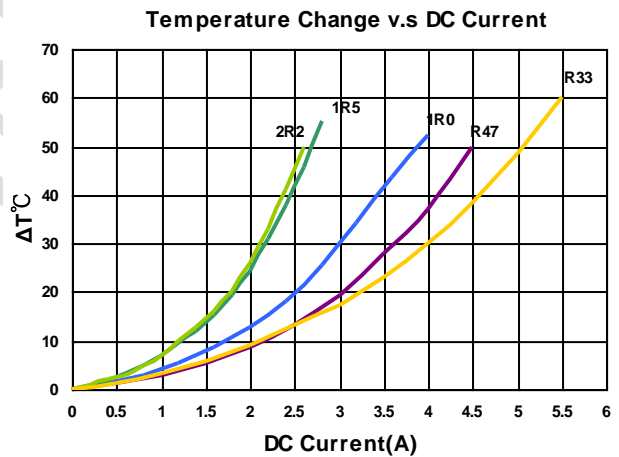
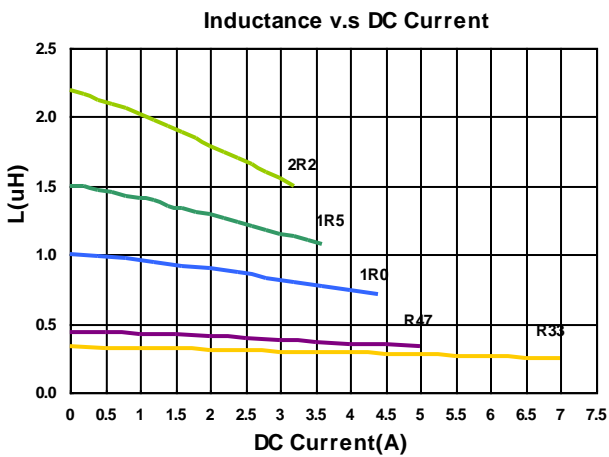

Molding Power Inductors – MHCD Series

Electrical Characteristics

| Part Number | Inductance (uH) | Tolerance (±%) | Test Frequency (MHz) | RDC(mΩ) Max(Typ.) | Isat(A) Max(Typ.) | Irms(A) Max(Typ.) |
|----------------------|-----------------|----------------|----------------------|-------------------|-------------------|-------------------|
| MHCD252012A-R33M-A8S | 0.33 | 20 | 2 | 35(27) | 6.8(8.5) | 4.0(4.6) |
| MHCD252012A-R47M-A8S | 0.47 | 20 | 2 | 39(29) | 6.2(7.8) | 3.7(4.4) |
| MHCD252012A-R68M-A8S | 0.68 | 20 | 2 | 46(40) | 5.5(6.5) | 3.3(3.7) |
| MHCD252012A-1R0M-A8S | 1.0 | 20 | 2 | 59(45) | 4.0(5.0) | 3.0(3.5) |
| MHCD252012A-1R5M-A8S | 1.5 | 20 | 2 | 70(62) | 3.4(4.0) | 2.5(2.7) |
| MHCD252012A-2R2M-A8S | 2.2 | 20 | 2 | 115(102) | 3.3(3.8) | 2.0(2.3) |

Note: When ordering, please specify tolerance code. Tolerance: M=±20%

- Operating temperature range - 40°C ~ 125°C(Including self - temperature rise)
- Isat for Inductance drop 30% from its value without current
- I rms for a 40°C temperature rise from 25°C ambient with current
- Absolute maximum voltage 25VDC
- Measure Equipment :
 L : Agilent E4991/HP4286A+16197A (or equivalent), 2MHz 0.2V
 RDC : CHEN HWA502BC/HP4338B (or equivalent)
 Isat : Agilent E4980A+HP42841A (or equivalent)
 I rms : Agilent 6641 SYSTEM DC POWER SUPPLY (or equivalent)

Test Instruments : E4991A Impedance / Material Analyzer

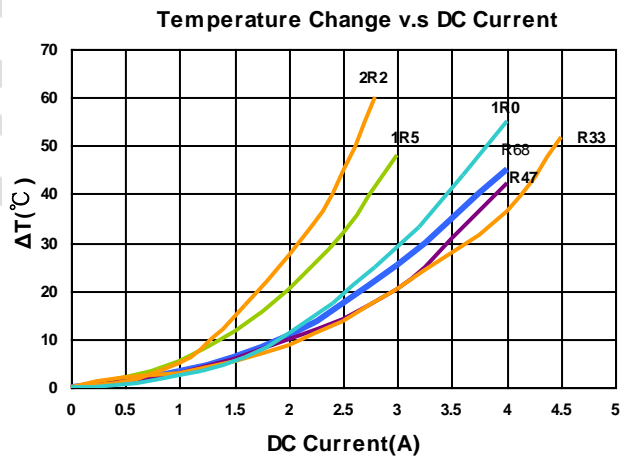
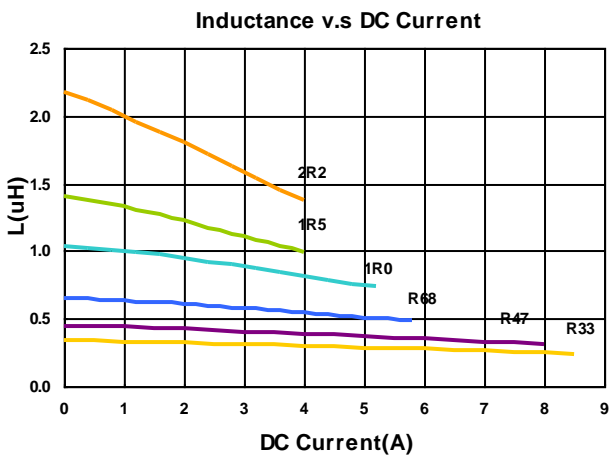

Molding Power Inductors – MHCD Series

Electrical Characteristics

| Part Number | Inductance (uH) | Tolerance (±%) | Test Frequency (MHz) | RDC(mΩ) Max(Typ.) | Isat(A) Max(Typ.) | Irms(A) Max(Typ.) |
|----------------------|-----------------|----------------|----------------------|-------------------|-------------------|-------------------|
| MHCD252012B-R47M-A8L | 0.47 | 20 | 2 | 34(30) | 5.2(6.0) | 4.1(4.7) |
| MHCD252012B-1R0M-A8L | 1.0 | 20 | 2 | 56(45) | 3.6(4.5) | 3.2(3.7) |
| MHCD252012B-2R2M-A8L | 2.2 | 20 | 2 | 102(80) | 2.5(3.0) | 2.2(2.6) |

Note: When ordering, please specify tolerance code. Tolerance: M=±20%

- Operating temperature range - 40°C ~ 125°C(Including self - temperature rise)
- Isat for Inductance drop 30% from its value without current
- I rms for a 40°C temperature rise from 25°C ambient with current
- Absolute maximum voltage 25VDC
- Measure Equipment :
 L : Agilent E4991/HP4286A+16197A (or equivalent), 2MHz 0.2V
 RDC : CHEN HWA502BC/HP4338B (or equivalent)
 Isat : Agilent E4980A+HP42841A (or equivalent)
 I rms : Agilent 6641 SYSTEM DC POWER SUPPLY (or equivalent)

Test Instruments : E4991A Impedance / Material Analyzer

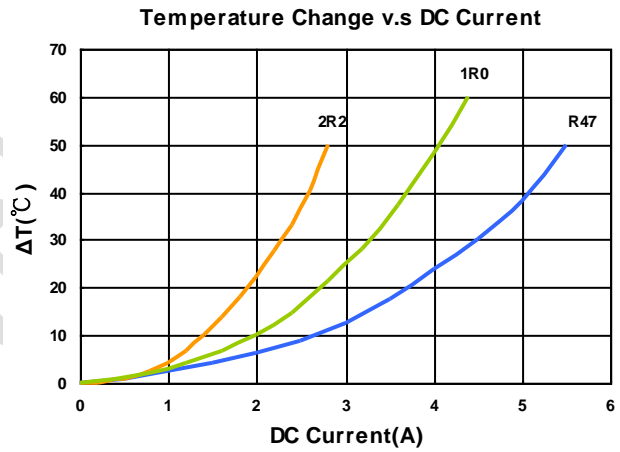
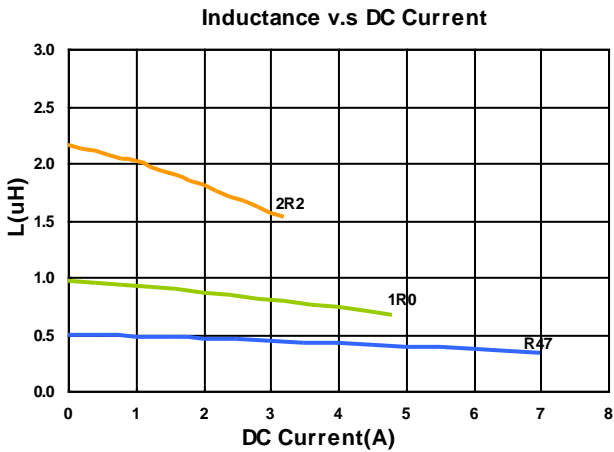

Molding Power Inductors – MHCD Series

Electrical Characteristics

| Part Number | Inductance (uH) | Tolerance (±%) | Test Frequency (MHz) | RDC(mΩ) Max(Typ.) | Isat(A) Max(Typ.) | Irms(A) Max(Typ.) |
|----------------------|-----------------|----------------|----------------------|-------------------|-------------------|-------------------|
| MHCD322510A-R47M-A8S | 0.47 | 20 | 2 | 37(30) | 5.8(6.6) | 3.6(4.2) |
| MHCD322510A-1R0M-A8S | 1.0 | 20 | 2 | 56(49) | 4.0(4.6) | 3.0(3.3) |
| MHCD322510A-1R5M-A8S | 1.5 | 20 | 2 | 75(66) | 3.4(4.0) | 2.6(3.0) |
| MHCD322510A-2R2M-A8S | 2.2 | 20 | 2 | 108(95) | 2.7(3.2) | 2.2(2.5) |

Note: When ordering, please specify tolerance code. Tolerance: M=±20%

- Operating temperature range - 40°C ~ 125°C(Including self - temperature rise)
- Isat for Inductance drop 30% from its value without current
- I rms for a 40°C temperature rise from 25°C ambient with current
- Absolute maximum voltage 25VDC
- Measure Equipment :
 L : Agilent E4991/HP4286A+16197A (or equivalent), 2MHz 0.2V
 RDC : CHEN HWA502BC/HP4338B (or equivalent)
 Isat : Agilent E4980A+HP42841A (or equivalent)
 I rms : Agilent 6641 SYSTEM DC POWER SUPPLY (or equivalent)

Test Instruments : E4991A Impedance / Material Analyzer

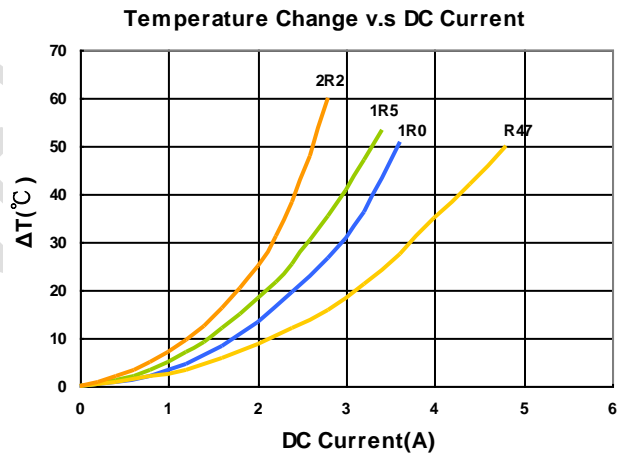
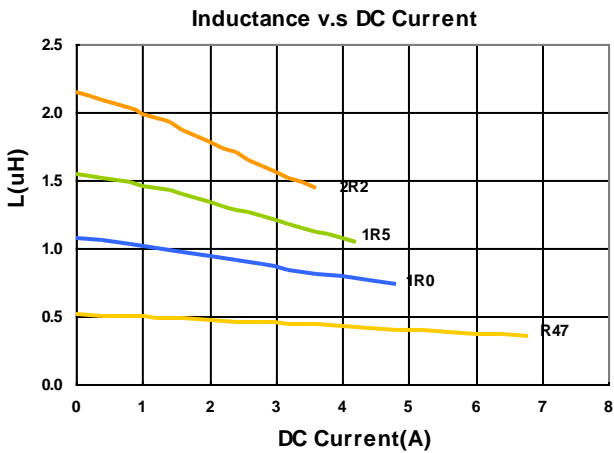

Molding Power Inductors – MHCD Series

Electrical Characteristics

| Part Number | Inductance (uH) | Tolerance (±%) | Test Frequency (MHz) | RDC(mΩ) Max(Typ.) | Isat(A) Max(Typ.) | Irms(A) Max(Typ.) |
|----------------------|-----------------|----------------|----------------------|-------------------|-------------------|-------------------|
| MHCD322512A-R47M-A8S | 0.47 | 20 | 2 | 27(21) | 8.0(9.0) | 5.0(5.8) |
| MHCD322512A-R68M-A8S | 0.68 | 20 | 2 | 34(26) | 6.3(7.5) | 4.0(4.6) |
| MHCD322512A-1R0M-A8S | 1.0 | 20 | 2 | 42(34) | 5.8(6.3) | 3.8(4.2) |
| MHCD322512A-1R5M-A8S | 1.5 | 20 | 2 | 68(58) | 4.0(4.5) | 2.8(3.2) |
| MHCD322512A-2R2M-A8S | 2.2 | 20 | 2 | 85(75) | 3.6(4.0) | 2.4(2.7) |

Note: When ordering, please specify tolerance code. Tolerance: M=±20%

- Operating temperature range - 40°C ~ 125°C(Including self - temperature rise)
- Isat for Inductance drop 30% from its value without current
- I rms for a 40°C temperature rise from 25°C ambient with current
- Absolute maximum voltage 25VDC
- Measure Equipment :
 L : Agilent E4991/HP4286A+16197A (or equivalent), 2MHz 0.2V
 RDC : CHEN HWA502BC/HP4338B (or equivalent)
 Isat : Agilent E4980A+HP42841A (or equivalent)
 I rms : Agilent 6641 SYSTEM DC POWER SUPPLY (or equivalent)

Test Instruments : E4991A Impedance / Material Analyzer

Inductance v.s DC Current

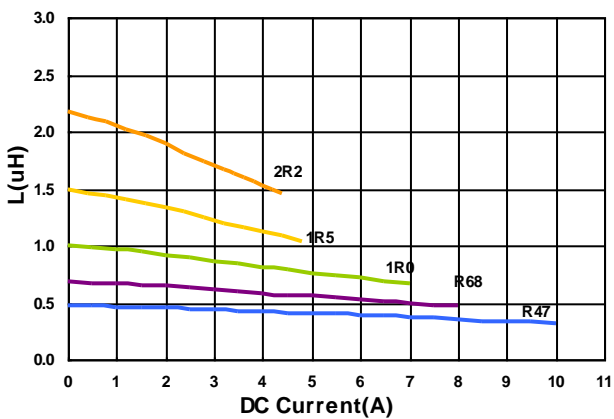

Temperature Change v.s DC Current

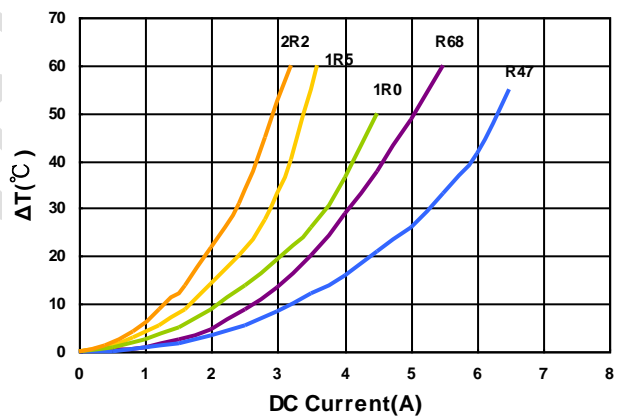

Packaging Specifications

Tape Dimensions

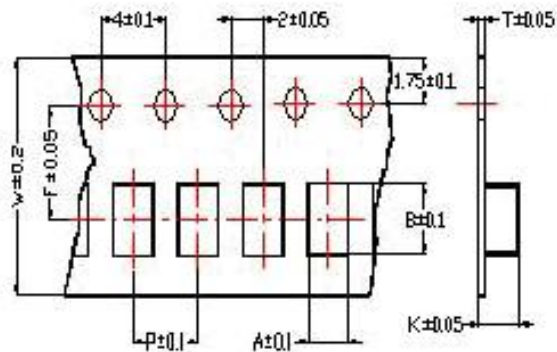

Tape Material

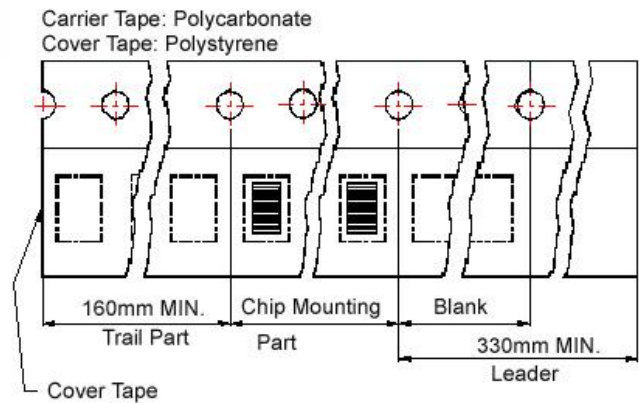

Reel Dimensions

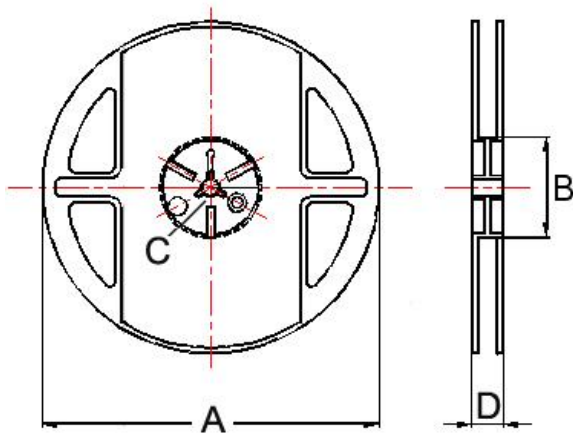

Dimensions in mm

| TYPE | Tape Dimensions | | | | | | | Reel Dimensions | | | | Quantity PCS / REEL |
|--------|-----------------|------|------|---|---|-----|------|-----------------|----|----|-----|------------------------|
| | A | B | T | W | P | F | K | A | B | C | D | |
| 201610 | 1.80 | 2.20 | 0.22 | 8 | 4 | 3.5 | 1.15 | 178 | 60 | 12 | 1.5 | 3000 |
| 201612 | 1.80 | 2.20 | 0.22 | 8 | 4 | 3.5 | 1.15 | 178 | 60 | 12 | 1.5 | 3000 |
| 252010 | 2.25 | 2.80 | 0.22 | 8 | 4 | 3.5 | 1.15 | 178 | 60 | 12 | 1.5 | 3000 |
| 252012 | 2.25 | 2.80 | 0.22 | 8 | 4 | 3.5 | 1.35 | 178 | 60 | 12 | 1.5 | 3000 |
| 322510 | 2.80 | 3.55 | 0.23 | 8 | 4 | 3.5 | 1.20 | 178 | 60 | 12 | 1.5 | 3000 |
| 322512 | 2.80 | 3.50 | 0.23 | 8 | 4 | 3.5 | 1.34 | 178 | 60 | 12 | 1.5 | 3000 |

X-ON Electronics

Largest Supplier of Electrical and Electronic Components

Click to view similar products for [Fixed Inductors](#) category:

Click to view products by [Chilisin](#) manufacturer:

Other Similar products are found below :

[MLZ1608M6R8WTD25](#) [MLZ1608N6R8LT000](#) [MLZ1608N3R3LTD25](#) [MLZ1608N3R3LT000](#) [MLZ1608N150LT000](#)

[MLZ1608M150WTD25](#) [MLZ1608M3R3WTD25](#) [MLZ1608M3R3WT000](#) [MLZ1608M150WT000](#) [MLZ1608A1R5WT000](#)

[MLZ1608N1R5LT000](#) [B82432C1333K000](#) [PCMB053T-1R0MS](#) [PCMB053T-1R5MS](#) [PCMB104T-1R5MS](#) [CR32NP-100KC](#) [CR32NP-](#)

[151KC](#) [CR32NP-180KC](#) [CR32NP-181KC](#) [CR32NP-1R5MC](#) [CR32NP-390KC](#) [CR32NP-3R9MC](#) [CR32NP-680KC](#) [CR32NP-820KC](#)

[CR32NP-8R2MC](#) [CR43NP-390KC](#) [CR43NP-560KC](#) [CR43NP-680KC](#) [CR54NP-181KC](#) [CR54NP-470LC](#) [CR54NP-820KC](#) [CR54NP-8R5MC](#)

[MGDQ4-00004-P](#) [MGDU1-00016-P](#) [MHL1ECTTP18NJ](#) [MHL1JCTTD12NJ](#) [PE-51506NL](#) [PE-53601NL](#) [PE-53630NL](#) [PE-53824SNLT](#) [PE-](#)

[62892NL](#) [PE-92100NL](#) [PG0434.801NLT](#) [PG0936.113NLT](#) [PM06-2N7](#) [PM06-39NJ](#) [HC2LP-R47-R](#) [HC2-R47-R](#) [HC3-2R2-R](#) [HC8-1R2-R](#)