

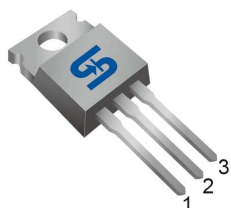

TO-220

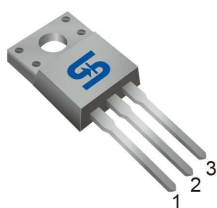

ITO-220



TO-251 (IPAK)

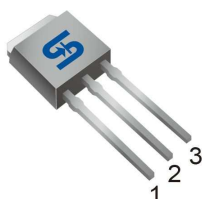

TO-252 (DPAK)



Pin Definition:

1. Gate
2. Drain
3. Source

PRODUCT SUMMARY

V_{DS} (V)	$R_{DS(on)}$ (Ω)	I_D (A)
600	4.4 @ $V_{GS}=10V$	1

General Description

The TSM2NB60 N-Channel Power MOSFET is produced by new advance planar process. This advanced technology has been especially tailored to minimize on-state resistance, provide superior switching performance, and withstand high energy pulse in the avalanche and commutation mode.

Features

- Low $R_{DS(ON)}$ 3.9 Ω (Typ.)
- Low gate charge typical @ 9.5nC (Typ.)
- Low C_{rss} typical @ 5pF (Typ.)
- 100% Avalanche Tested

Ordering Information

Part No.	Package	Packing
TSM2NB60CH C5G	TO-251	75pcs / Tube
TSM2NB60CP ROG	TO-252	2.5Kpcs / 13" Reel
TSM2NB60CZ C0	TO-220	50pcs / Tube
TSM2NB60CI C0	ITO-220	50pcs / Tube

Note: "G" denotes for Halogen Free

Block Diagram

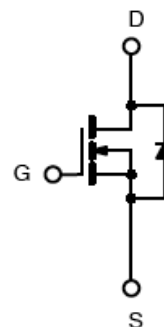

N-Channel MOSFET

Absolute Maximum Rating ($T_a = 25^\circ C$ unless otherwise noted)

Parameter	Symbol	Limit			Unit
		IPAK/DPAK	ITO-220	TO-220	
Drain-Source Voltage	V_{DS}	600			V
Gate-Source Voltage	V_{GS}	± 30			V
Continuous Drain Current	I_D	$T_C = 25^\circ C$			A
		$T_C = 100^\circ C$			A
Pulsed Drain Current *	I_{DM}	8			A
Single Pulse Avalanche Energy (Note 2)	E_{AS}	55			mJ
Avalanche Current (Repetitive) (Note 1)	I_{AR}	2			A
Repetitive Avalanche Energy (Note 1)	E_{AR}	4.4			mJ
Peak Diode Recovery dv/dt (Note 3)	dv/dt	4.5			V/ns
Total Power Dissipation @ $T_C = 25^\circ C$	P_{TOT}	44	25	70	W
Operating Junction Temperature	T_J	150			$^\circ C$
Storage Temperature Range	T_{STG}	-55 to +150			$^\circ C$

Note: Limited by maximum junction temperature

Thermal Performance

Parameter	Symbol	Limit			Unit
		IPAK/DPAK	ITO-220	TO-220	
Thermal Resistance - Junction to Case	$R\theta_{JC}$	2.87	5	1.78	$^{\circ}\text{C/W}$
Thermal Resistance - Junction to Ambient	$R\theta_{JA}$	110	62.5	62.5	$^{\circ}\text{C/W}$

Electrical Specifications (Ta = 25 $^{\circ}$ C unless otherwise noted)

Parameter	Conditions	Symbol	Min	Typ	Max	Unit
Static						
Drain-Source Breakdown Voltage	$V_{GS} = 0V, I_D = 250\mu\text{A}$	BV_{DSS}	600	--	--	V
Drain-Source On-State Resistance	$V_{GS} = 10V, I_D = 1A$	$R_{DS(ON)}$	--	3.9	4.4	Ω
Gate Threshold Voltage	$V_{DS} = V_{GS}, I_D = 250\mu\text{A}$	$V_{GS(TH)}$	2.5	3.6	4.5	V
Zero Gate Voltage Drain Current	$V_{DS} = 600V, V_{GS} = 0V$	I_{DSS}	--	--	10	μA
Gate Body Leakage	$V_{GS} = \pm 30V, V_{DS} = 0V$	I_{GSS}	--	--	± 100	nA
Forward Transfer Conductance	$V_{DS} = 40V, I_D = 1A$	g_{fs}	--	1.5	--	S
Dynamic						
Total Gate Charge	$V_{DS} = 480V, I_D = 2A,$ $V_{GS} = 10V$ (Note 4,5)	Q_g	--	9.4	--	nC
Gate-Source Charge		Q_{gs}	--	2.2	--	
Gate-Drain Charge		Q_{gd}	--	4.7	--	
Input Capacitance	$V_{DS} = 25V, V_{GS} = 0V,$ $f = 1.0\text{MHz}$	C_{iss}	--	249	--	pF
Output Capacitance		C_{oss}	--	30.7	--	
Reverse Transfer Capacitance		C_{rss}	--	5	--	
Switching						
Turn-On Delay Time	$V_{GS} = 10V, I_D = 2A,$ $V_{DD} = 300V, R_G = 25\Omega$ (Note 4,5)	$t_{d(on)}$	--	9.1	--	nS
Turn-On Rise Time		t_r	--	9.8	--	
Turn-Off Delay Time		$t_{d(off)}$	--	17.4	--	
Turn-Off Fall Time		t_f	--	12.4	--	
Source-Drain Diode Ratings and Characteristic						
Source Current	Integral reverse diode in the MOSFET	I_S	--	--	2	A
Source Current (Pulse)		I_{SM}	--	--	8	A
Diode Forward Voltage	$I_S = 2A, V_{GS} = 0V$	V_{SD}	--	0.9	1.4	V
Reverse Recovery Time	$V_{GS} = 0V, I_S = 2A,$ $di/dt = 100A/\mu\text{s}$	t_{fr}	--	490	--	nS
Reverse Recovery Charge		Q_{fr}	--	0.8	--	μC

Note 1: Repetitive Rating: Pulse Width Limited by Maximum Junction Temperature

Note 2: $V_{DD} = 50V, I_{AS} = 2A, L = 25\text{mH}, R_G = 25\Omega,$ Starting $T_J = 25^{\circ}\text{C}$

Note 3: $I_{SD} \leq 2A, di/dt \leq 200A/\mu\text{S}, V_{DD} \leq BV_{DSS},$ Starting $T_J = 25^{\circ}\text{C}$

Note 4: Pulse test: pulse width $\leq 300\mu\text{S},$ duty cycle $\leq 2\%$

Note 5: Essentially Independent of Operating Temperature



Gate Charge Test Circuit & Waveform

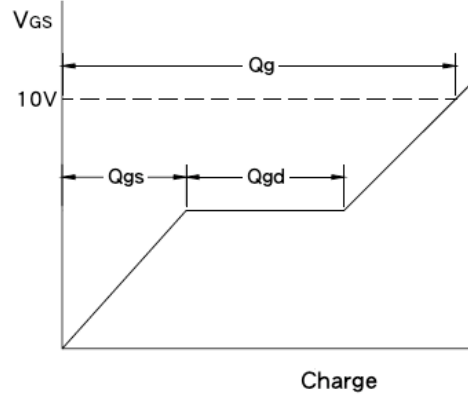
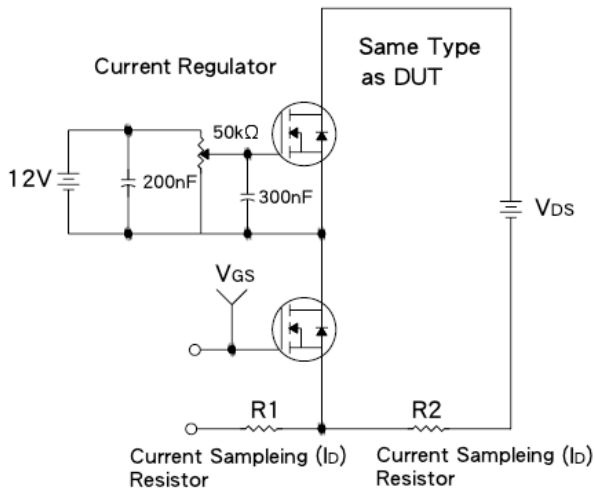

Resistive Switching Test Circuit & Waveform

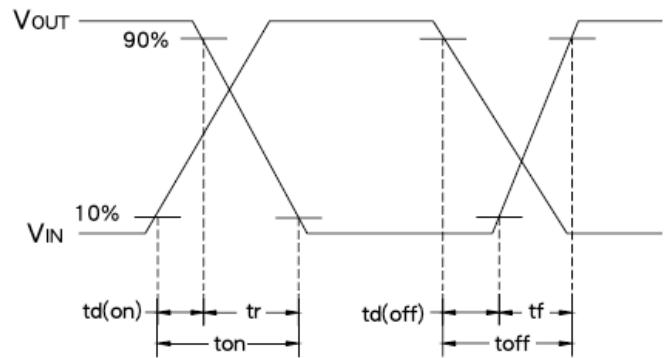
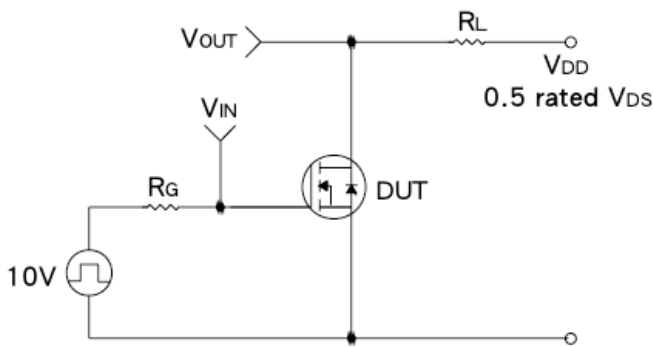

E_{AS} Test Circuit & Waveform

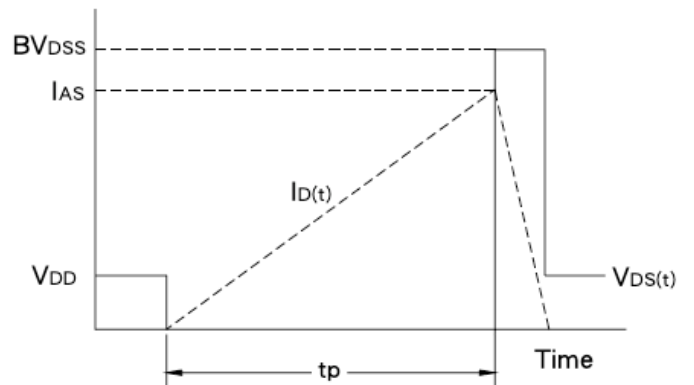
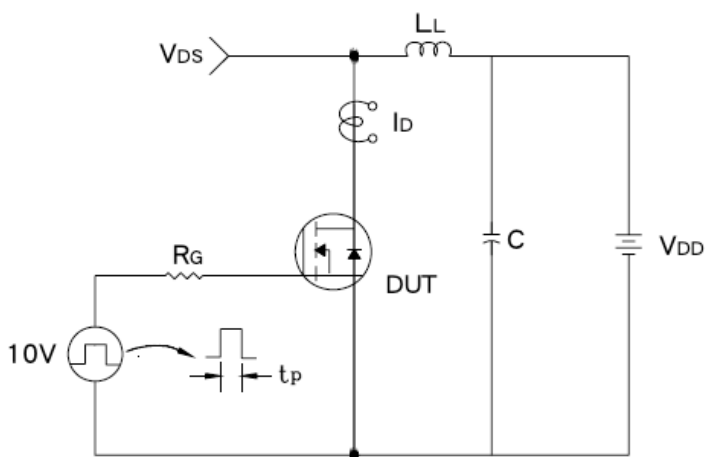

Diode Reverse Recovery Time Test Circuit & Waveform

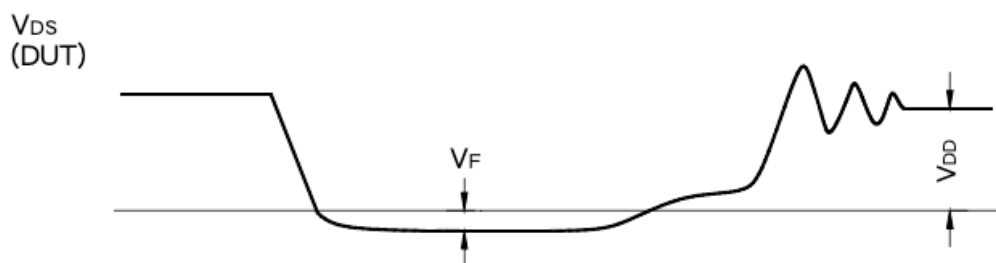
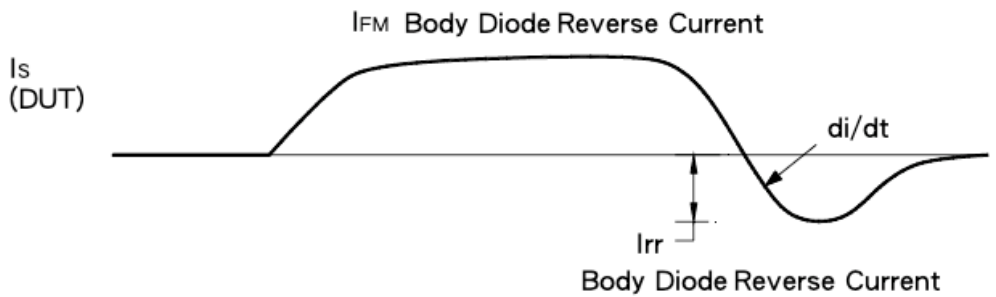
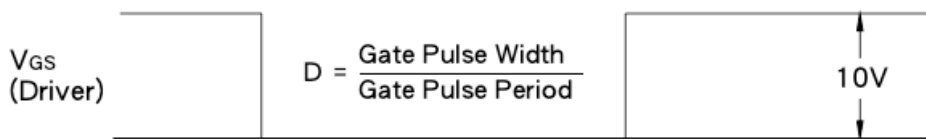
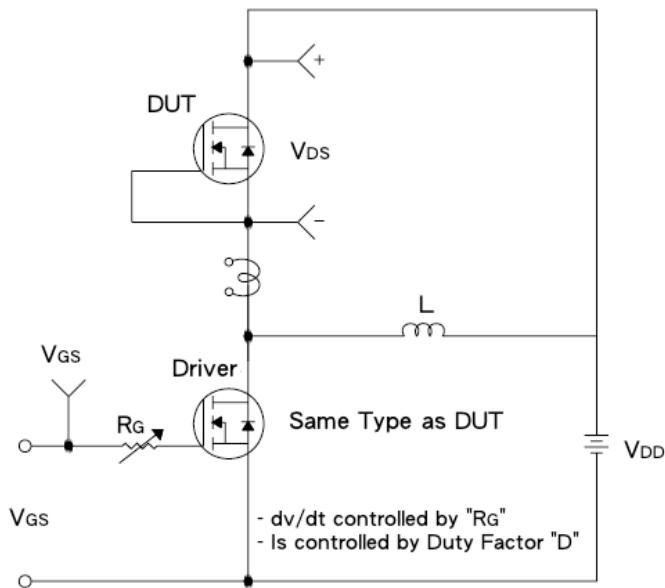



Electrical Characteristics Curve (Ta = 25°C, unless otherwise noted)

Output Characteristics

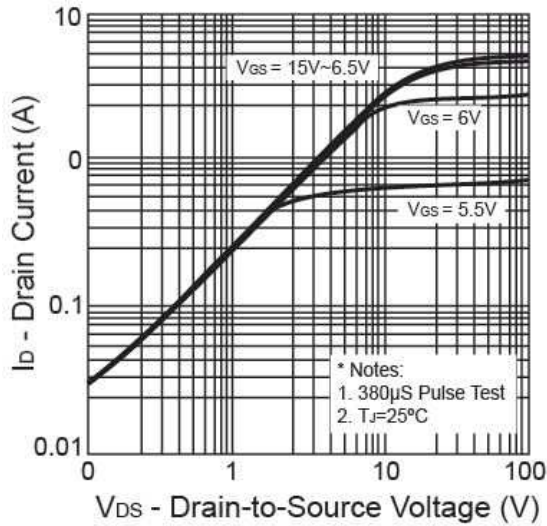

Transfer Characteristics

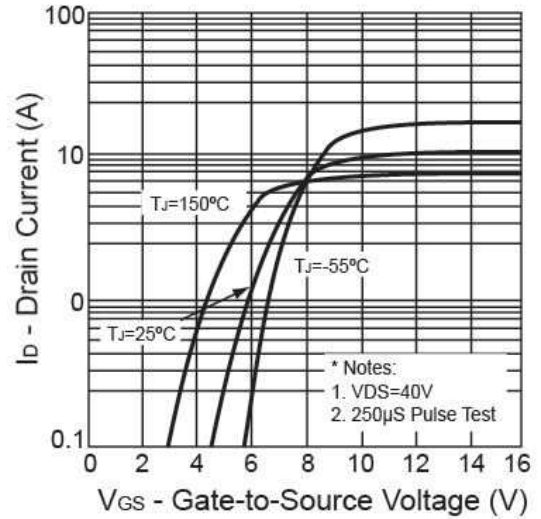

On-Resistance vs. Drain Current

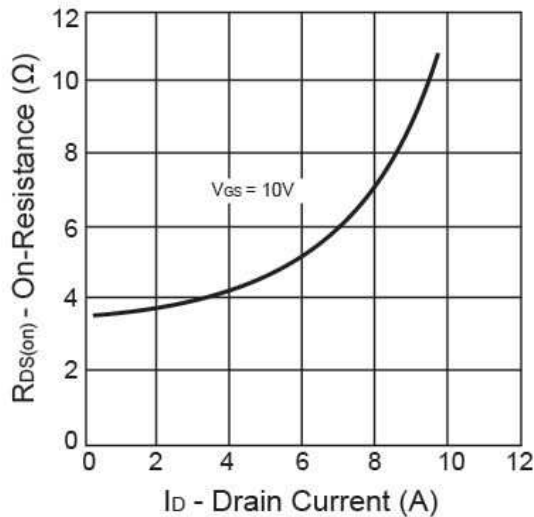

Gate Charge

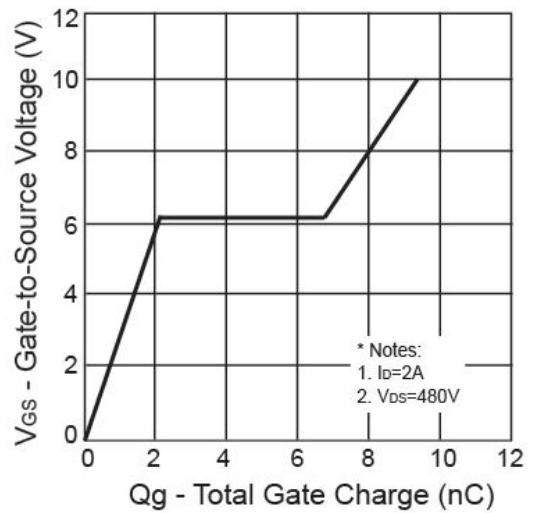

TO-220 Mechanical Drawing

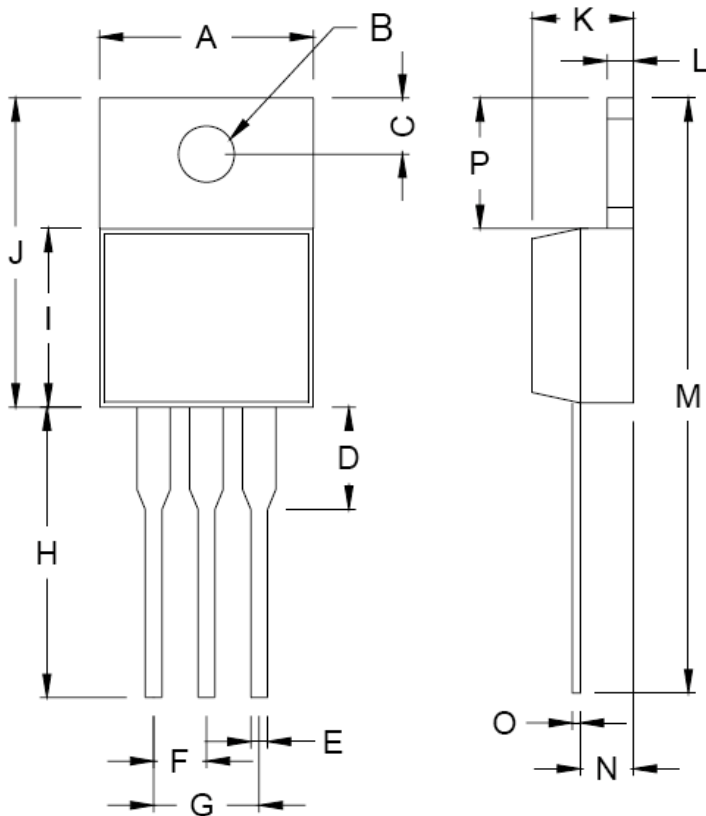

DIM	TO-220 DIMENSION			
	MILLIMETERS		INCHES	
	MIN	MAX	MIN	MAX
A	10.000	10.500	0.394	0.413
B	3.740	3.910	0.147	0.154
C	2.440	2.940	0.096	0.116
D	-	6.350	-	0.250
E	0.381	1.106	0.015	0.040
F	2.345	2.715	0.092	0.058
G	4.690	5.430	0.092	0.107
H	12.700	14.732	0.500	0.581
J	14.224	16.510	0.560	0.650
K	3.556	4.826	0.140	0.190
L	0.508	1.397	0.020	0.055
M	27.700	29.620	1.060	1.230
N	2.032	2.921	0.080	0.115
O	0.255	0.610	0.010	0.024
P	5.842	6.858	0.230	0.270

Marking Diagram

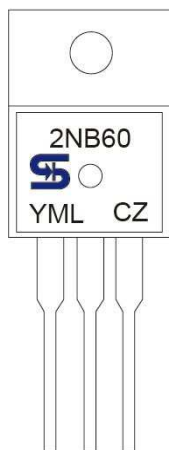

- Y** = Year Code
- M** = Month Code
(A=Jan, B=Feb, C=Mar, D=Apl, E=May, F=Jun, G=Jul, H=Aug, I=Sep, J=Oct, K=Nov, L=Dec)
- L** = Lot Code

ITO-220 Mechanical Drawing

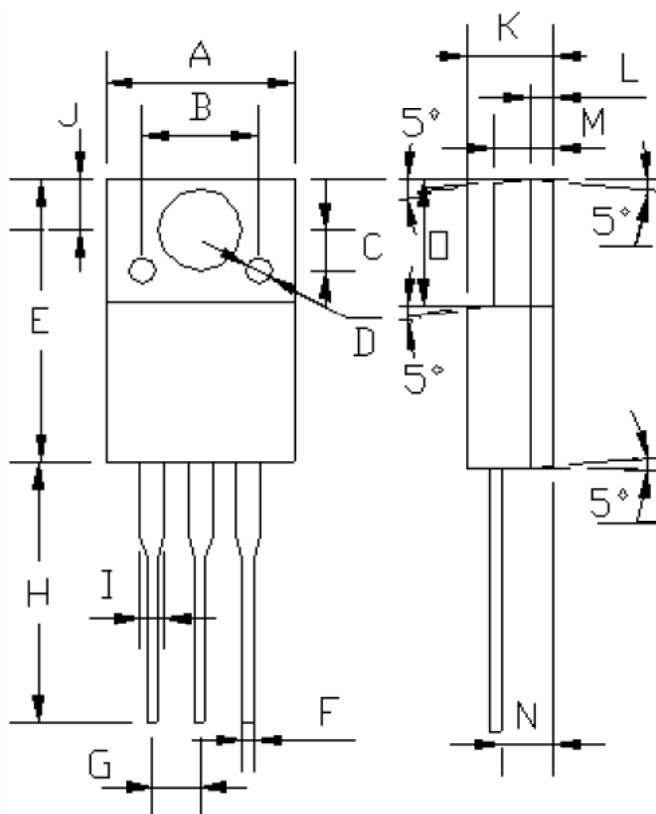

ITO-220 DIMENSION				
DIM	MILLIMETERS		INCHES	
	MIN	MAX	MIN	MAX
A	10.04	10.07	0.395	0.396
B	6.20 (typ.)		0.244 (typ.)	
C	2.20 (typ.)		0.087 (typ.)	
D	§ 1.40 (typ.)		§ 0.055 (typ.)	
E	15.0	15.20	0.591	0.598
F	0.52	0.54	0.020	0.021
G	2.35	2.73	0.093	0.107
H	13.50	13.55	0.531	0.533
I	1.11	1.49	0.044	0.058
J	2.60	2.80	0.102	0.110
K	4.49	4.50	0.176	0.177
L	1.15 (typ.)		0.045 (typ.)	
M	3.03	3.05	0.119	0.120
N	2.60	2.80	0.102	0.110
O	6.55	6.65	0.258	0.262

Marking Diagram

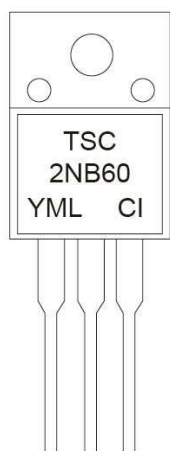

- Y** = Year Code
- M** = Month Code
(**A**=Jan, **B**=Feb, **C**=Mar, **D**=Apr, **E**=May, **F**=Jun, **G**=Jul, **H**=Aug, **I**=Sep, **J**=Oct, **K**=Nov, **L**=Dec)
- L** = Lot Code

TO-251 Mechanical Drawing

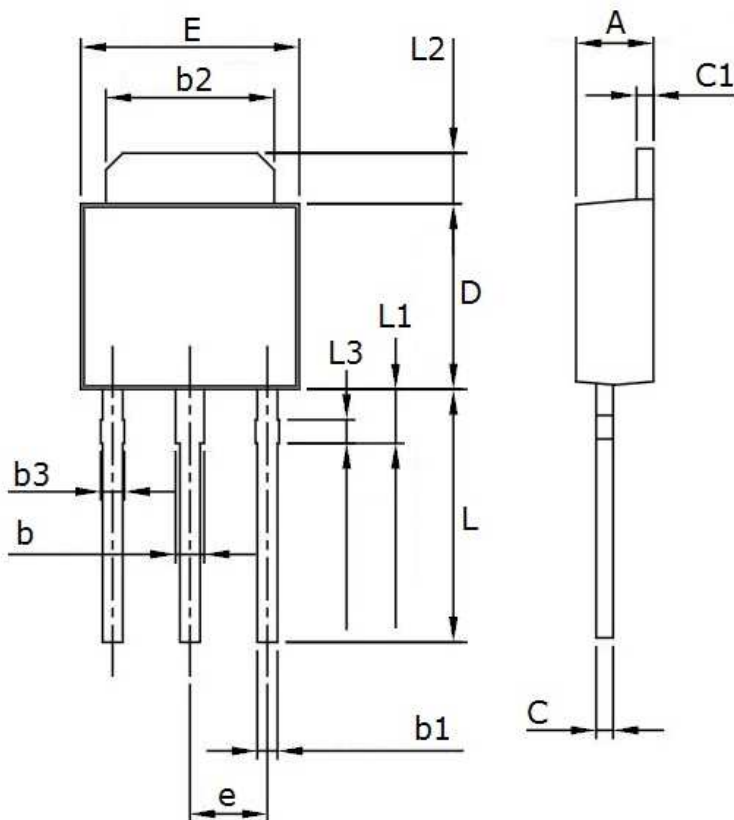

TO-251 DIMENSION				
DIM	MILLIMETERS		INCHES	
	MIN	MAX	MIN	MAX
A	2.10	2.50	0.083	0.098
b	0.65	1.05	0.026	0.041
b1	0.58	0.62	0.023	0.024
b2	4.80	5.20	0.189	0.205
b3	0.68	0.72	0.027	0.028
C	0.35	0.65	0.014	0.026
C1	0.40	0.60	0.016	0.024
D	5.30	5.70	0.209	0.224
E	6.30	6.70	0.248	0.264
e	2.30 BSC		0.09 BSC	
L	7.00	8.00	0.276	0.315
L1	1.40	1.80	0.055	0.071
L2	1.30	1.70	0.051	0.067
L3	0.50	0.90	0.020	0.035

Marking Diagram

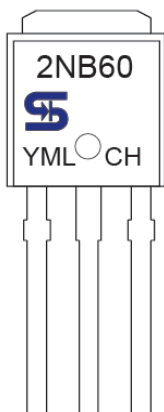

- Y** = Year Code
- M** = Month Code for Halogen Free Product
(O=Jan, P=Feb, Q=Mar, R=Apl, S=May, T=Jun, U=Jul, V=Aug, W=Sep, X=Oct, Y=Nov, Z=Dec)
- L** = Lot Code

TO-252 Mechanical Drawing

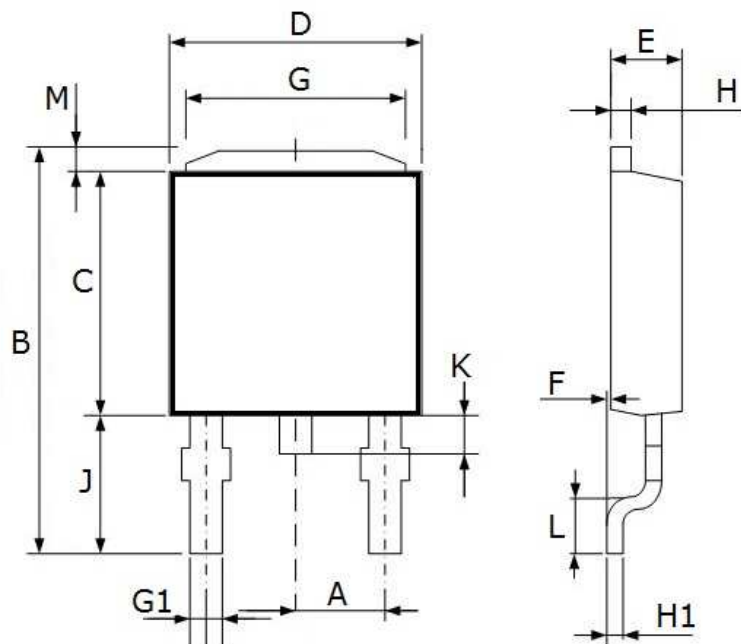

TO-252 DIMENSION				
DIM	MILLIMETERS		INCHES	
	MIN	MAX	MIN	MAX
A	2.30 BSC		0.090 BSC	
B	10.20	10.80	0.402	0.425
C	5.30	5.70	0.209	0.224
D	6.30	6.70	0.248	0.264
E	2.10	2.50	0.083	0.098
F	0.00	0.20	0.000	0.008
G	4.80	5.20	0.189	0.205
G1	0.40	0.80	0.016	0.031
H	0.40	0.60	0.016	0.024
H1	0.35	0.65	0.014	0.026
J	3.35	3.65	0.132	0.144
K	0.50	1.10	0.020	0.043
L	0.90	1.50	0.035	0.059
M	1.30	1.70	0.051	0.067

Marking Diagram

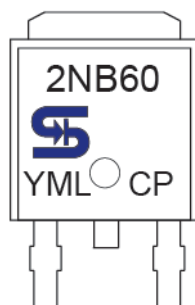

- Y** = Year Code
- M** = Month Code for Halogen Free Product
(O=Jan, P=Feb, Q=Mar, R=Apl, S=May, T=Jun, U=Jul, V=Aug, W=Sep, X=Oct, Y=Nov, Z=Dec)
- L** = Lot Code

Notice

Specifications of the products displayed herein are subject to change without notice. TSC or anyone on its behalf, assumes no responsibility or liability for any errors or inaccuracies.

Information contained herein is intended to provide a product description only. No license, express or implied, to any intellectual property rights is granted by this document. Except as provided in TSC's terms and conditions of sale for such products, TSC assumes no liability whatsoever, and disclaims any express or implied warranty, relating to sale and/or use of TSC products including liability or warranties relating to fitness for a particular purpose, merchantability, or infringement of any patent, copyright, or other intellectual property right.

The products shown herein are not designed for use in medical, life-saving, or life-sustaining applications. Customers using or selling these products for use in such applications do so at their own risk and agree to fully indemnify TSC for any damages resulting from such improper use or sale.

X-ON Electronics

Largest Supplier of Electrical and Electronic Components

Click to view similar products for [MOSFET](#) category:

Click to view products by [Taiwan Semiconductor](#) manufacturer:

Other Similar products are found below :

[614233C](#) [648584F](#) [MCH3443-TL-E](#) [MCH6422-TL-E](#) [FDPF9N50NZ](#) [FW216A-TL-2W](#) [FW231A-TL-E](#) [APT5010JVR](#) [NTNS3A92PZT5G](#)
[IRF100S201](#) [JANTX2N5237](#) [2SK2464-TL-E](#) [2SK3818-DL-E](#) [FCA20N60_F109](#) [FDZ595PZ](#) [STD6600NT4G](#) [FSS804-TL-E](#) [2SJ277-DL-E](#)
[2SK1691-DL-E](#) [2SK2545\(Q,T\)](#) [D2294UK](#) [405094E](#) [423220D](#) [MCH6646-TL-E](#) [TPCC8103,L1Q\(CM](#) [367-8430-0972-503](#) [VN1206L](#)
[424134F](#) [026935X](#) [051075F](#) [SBVS138LT1G](#) [614234A](#) [715780A](#) [NTNS3166NZT5G](#) [751625C](#) [873612G](#) [IRF7380TRHR](#)
[IPS70R2K0CEAKMA1](#) [RJK60S3DPP-E0#T2](#) [RJK60S5DPK-M0#T0](#) [APT5010JVFR](#) [APT12031JFLL](#) [APT12040JVR](#) [DMN3404LQ-7](#)
[NTE6400](#) [JANTX2N6796U](#) [JANTX2N6784U](#) [JANTXV2N5416U4](#) [SQM110N05-06L-GE3](#) [SIHF35N60E-GE3](#)