

36.6	34.85	31.2	29	52610-30	34	30
34.6	32.85	29.2	27	-28	34	28
32.6	30.85	27.2	25	-26	34	26
31.6	29.85	26.2	24	-25	34	25
30.6	28.85	25.2	23	-24	34	24
29.6	27.85	24.2	22	-23	34	23
28.6	26.85	23.2	21	-22	34	22
27.6	25.85	22.2	20	-21	34	21
26.6	24.85	21.2	19	-20	34	20
25.6	23.85	20.2	18	-19	34	19
24.6	22.85	19.2	17	-18	34	18
22.6	20.85	17.2	15	-16	34	16
21.6	19.85	16.2	14	-15	34	15
20.6	18.85	15.2	13	-14	34	14
19.6	17.85	14.2	12	-13	34	13
18.6	16.85	13.2	11	-12	34	12
16.6	14.85	11.2	9	-10	34	10
15.6	13.85	10.2	8	-09	34	9
14.6	12.85	9.2	7	-08	34	8
13.6	11.85	8.2	6	-07	34	7
12.6	10.85	7.2	5	52610-06	34	6
D	(C)	B	(A)	EMBOSSED PACKAGE ORDER No. オーダー番号		極数 CKT.

CONNECTOR SERIES NO. : 52610-\*\*\*23

REVISED EC NO: J2014-0096 DRWN: AISHII 2013/07/18 CHKD: TAKAHASHI 2013/07/18 APPR: YNOGAWA 2013/08/19	GENERAL TOLERANCES (UNLESS SPECIFIED)		DIMENSION STYLE MM ONLY		SCALE ---	DESIGN UNITS METRIC	THIRD ANGLE PROJECTION	
	10 UNDER ±0.2	10 OVER 30 UNDER ±0.25	30 OVER ±0.3	ANGULAR ±3 °	DRAFT WHERE APPLICABLE MUST REMAIN WITHIN DIMENSIONS	DRAWN BY AISHII	DATE 2013/02/20	TITLE 1.0 FPC CONN ZIF S/T HOUSING ASSY  <b>molex</b> DOCUMENT NO. SD-52610-050
	SEE SHEET 2		MATERIAL NO.	SHEET NO. 1 OF 2				
	THIS DRAWING CONTAINS INFORMATION THAT IS PROPRIETARY TO MOLEX INCORPORATED AND SHOULD NOT BE USED WITHOUT WRITTEN PERMISSION							

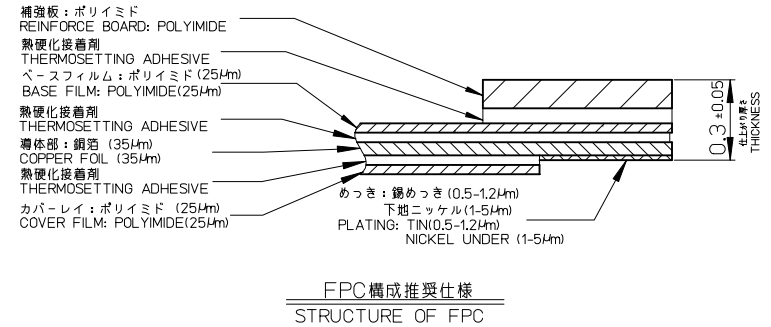
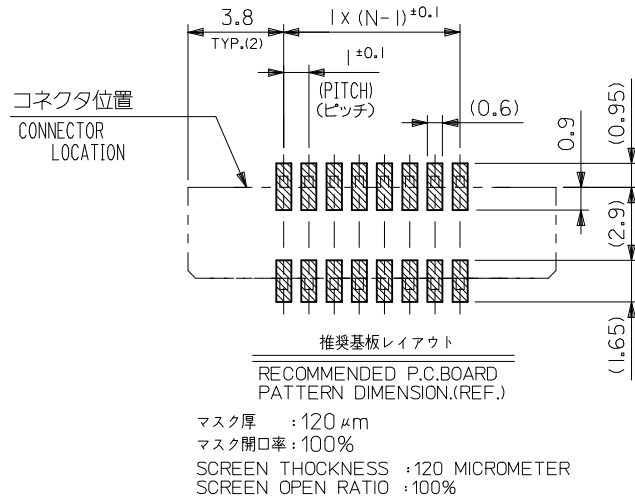
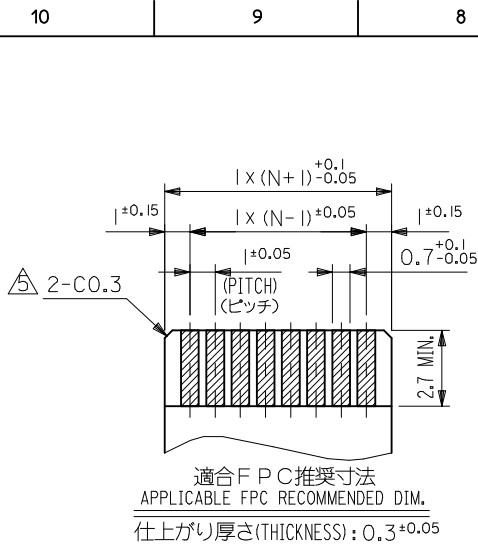

注記 (NOTES):

1. 材質 MATERIAL

ハウジング: ポリアミド (PA), ナチュラル (白色), ガラス充填, UL94V-0  
HOUSING : POLYAMIDE, NATURAL (WHITE), GLASS FILLED, UL94V-0  
アクチュエータ: ポリフェニレンサルファイド (PPS), ナチュラル (茶色), ガラス充填, UL94V-0  
ACTUATOR : POLYPHENYLENE SULFID, NATURAL (BROWN), GLASS FILLED, UL94V-0  
ターミナル: リン青銅 (t=0.32)  
TERMINAL : PHOSPHOR BRONZE (t=0.32)

2. めっき仕様 PLATING

ターミナル TERMINAL  
錫銀ビスマスめっき (1.0 μm以上)  
TIN SILVER BISMUTH PLATING (1.0 MICROMETER MINIMUM)  
下地: ニッケルめっき (1.0 μm以上)  
UNDER PLATING : NICKEL PLATING (1.0 MICROMETER MINIMUM)

ソルダーテール半田付け面のズレ量は、基準面  $\square$  に対し上方向0.05MAX., 下方向0.15MAX.とする。  
MISALIGNMENT OF SOLDER TAILS FROM  $\square$  UPPER DIRECTION : 0.05 MAX. LOWER DIRECTION : 0.15 MAX.

偶数極に適用  
APPLY FOR EVEN CIRCUIT.

R0.3はFPCの導体部にかからないこと。  
R0.3 MUST NOT BE OVERLAPED TO PATTERN OF FPC.

エンボステープ梱包時は、アクチュエータがロックした状態とする。  
IN THE PACKAGE, ACTUATOR OF PART NO.52610-\*\*23 SHOULD BE LOCKED.

ソルダーテールの平坦度は0.1mm以下とする。  
SOLDERTAIL COPLANARITY IS 0.1MM MAXIMUM.

ELV及びRoHS適合品  
ELV AND RoHS COMPLIANT

FPCについて ABOUT FPC

打ち抜き方向は導体側から補強板側を推奨します。  
導体部については軟烙銅35 μmまたは50 μmを推奨します。  
補強フィルム材質はポリイミドを推奨します。ベースフィルムは25 μmを推奨します。  
接着剤は熱硬化接着剤を推奨します。  
尚、接着剤の接点部への付着は導通不良の原因になりますので、染み出しが無い様、お願い致します。  
RECOMMENDED PUNCHING DIRECTION: FROM CONDUCTOR SIDE TO STIFFENER SIDE  
RECOMMENDED CONDUCTOR SPEC: SOFT COPPER FOIL  
RECOMMENDED CONDUCTOR THICKNESS: 35 MICROMETER OR 50 MICROMETER  
RECOMMENDED STIFFENER MATERIAL: POLYIMIDE  
RECOMMENDED BASE FILM THICKNESS: 25 MICROMETER  
RECOMMENDED ADHESIVE: THERMOSETTING ADHESIVE  
NOTE: PLEASE PUT APPROPRIATE AMOUNT OF ADHESIVE ON ADHEREND BECAUSE THERE IS A POSSIBILITY THAT THE EXTRA ADHESIVE CAUSES THE DEFECT IN ELECTRICAL CONTINUITY.

SEE SHEET 1 OF 2 EC NO: J2014-0096 DRW: AISHII 2013/07/18 CHKD: KAKAHASHI 2013/07/18 APPR: YNOGAWA 2013/08/19	GENERAL TOLERANCES (UNLESS SPECIFIED)		DIMENSION STYLE MM ONLY	SCALE ---	DESIGN UNITS METRIC	THIRD ANGLE PROJECTION
	10 UNDER	±0.2	DRAWN BY AISHII	DATE 2013/02/20	TITLE 1.0 FPC CONN ZIF S/T HOUSING ASSY	
	10 OVER 30 UNDER	±0.25	CHECKED BY KAKAHASHI	DATE 2013/02/20		
	30 OVER	±0.3	APPROVED BY KMORIKAWA	DATE 2013/03/15		
ANGULAR	±3 °	MATERIAL NO. SEE CHART		DOCUMENT NO. SD-52610-050		SHEET NO. 2 OF 2
DRAFT WHERE APPLICABLE MUST REMAIN WITHIN DIMENSIONS		SIZE A3	THIS DRAWING CONTAINS INFORMATION THAT IS PROPRIETARY TO MOLEX INCORPORATED AND SHOULD NOT BE USED WITHOUT WRITTEN PERMISSION			

NOTES

- 52610-\*\*\*23のアクチュエータはハウジング内に押し下げた状態とする。  
詳細寸法については図面SD-52610-050をご参照ください。  
ACTUATOR OF PART NO. 52610-\*\*\*23 SHULD BE LOCKED.  
RE DETAILED DIMENSIONS, SEE SD-52610-050
- 梱包数量：1000個/リール  
NUMBER OF CONNECTORS：1000PCS/REEL
- リードテープ長さ  
LEAD TAPE LENGTH

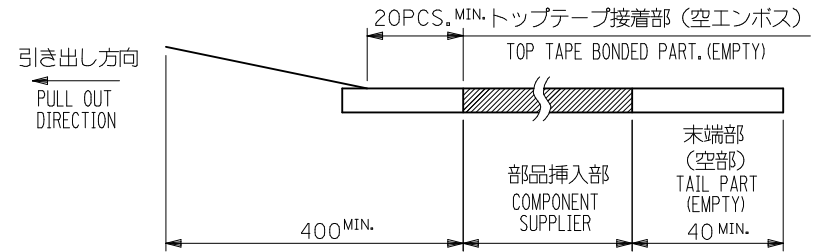
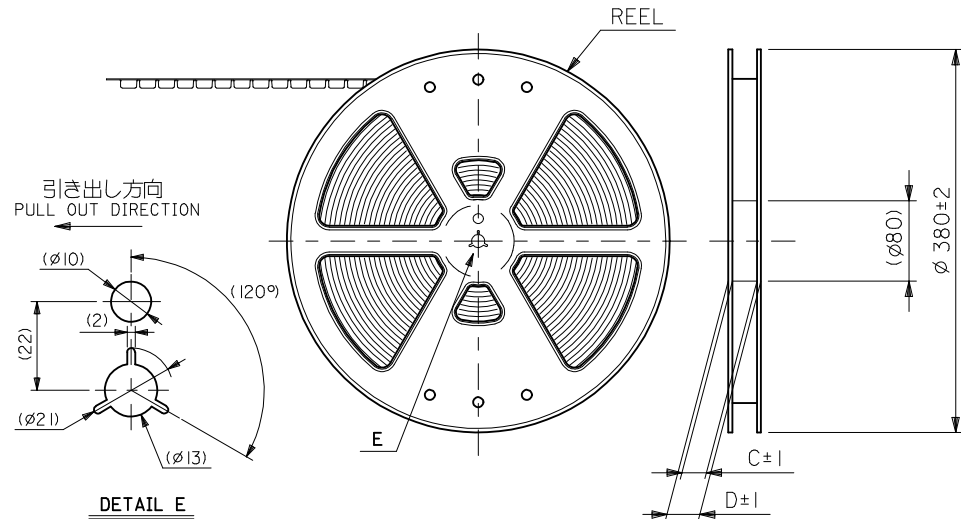

- カバーテープの剥離強度については、IEC60286-3に準拠  
COVER TAPE PEEL FORCE IS DEFINED BY IEC60286-3.
- 材料(MATERIAL)  
キャリアテープ (CARRIER TAPE)：ポリプロピレン (POLYPROPYLENE)  
トップテープ (TOP TAPE)：PET, PE, PEF  
リール(REEL)：ポリスチレン(PS)<リサイクル材を含む>  
POLYSTYREN(PS) <RECYCLE MATERIAL CONTAINED>
- ELV及びRoHS適合品  
ELV AND RoHS COMPLIANT

RELEASED EC NO.: J2013-1003 DRW: AISHII 2013/02/20 CHK: KTAKAHASHI 2013/02/20 APPR: KMORIKAWA 2013/03/15	GENERAL TOLERANCES (UNLESS SPECIFIED)		DIMENSION STYLE MM ONLY		SCALE ---	DESIGN UNITS METRIC	THIRD ANGLE PROJECTION
	10 UNDER	±0.3	DRAWN BY AISHII	DATE 2013/02/20	TITLE EMBOSS TAPE PACKAGED FOR 1.0 FPC CONN ZIF S/T HOUSING ASSY		
	10 OVER 30 UNDER	±0.25	CHECKED BY KTAKAHASHI	DATE 2013/02/20			
	30 OVER	±0.2	APPROVED BY KMORIKAWA	DATE 2013/03/15			
	ANGULAR ±3 °		MATERIAL NO. SEE CHART		DOCUMENT NO. SD-52610-051		SHEET NO. 1 OF 5
DRAFT WHERE APPLICABLE MUST REMAIN WITHIN DIMENSIONS		THIS DRAWING CONTAINS INFORMATION THAT IS PROPRIETARY TO MOLEX INCORPORATED AND SHOULD NOT BE USED WITHOUT WRITTEN PERMISSION					

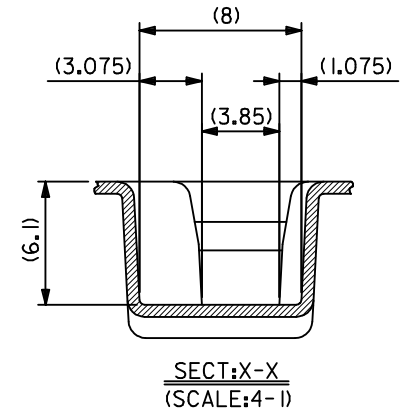
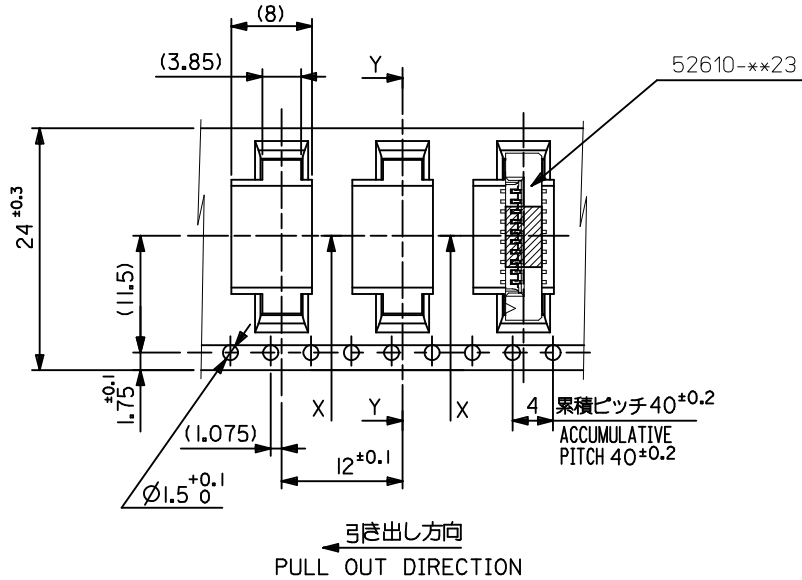
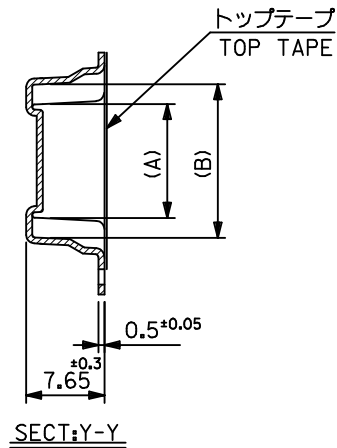

24	29.4	25.4	15.25	11.32	52610-1034	10
			14.25	10.32	52610-0934	9
			13.25	9.32	52610-0834	8
			12.25	8.32	52610-0734	7
			11.25	7.32	52610-0634	6
キャリアテープ幅 CARRIER TAPE WIDTH	D	C	(B)	(A)	MATERIAL. NO.	極数 CKT.

SEE SHEET 1 OF 5 EC NO.: J2013-1003 DRWN: AISHII 2013/02/20 CHKD: TAKAHASHI 2013/02/20 APPR: KMORIKAWA 2013/03/15	DESCRIPTION REV: 0	GENERAL TOLERANCES (UNLESS SPECIFIED)		DIMENSION STYLE MM ONLY		SCALE ---		DESIGN UNITS METRIC		THIRD ANGLE PROJECTION		
		10 UNDER	±0.3	DRAWN BY	DATE	TITLE EMBOSS TAPE PACKAGED FOR 1.0 FPC CONN ZIF S/T HOUSING ASSY						
		10 OVER 30 UNDER	±0.25	CHECKED BY	DATE	<b>molex</b>						
		30 OVER	±0.2	APPROVED BY	DATE							
		ANGULAR ±3 °		DRAFT WHERE APPLICABLE MUST REMAIN WITHIN DIMENSIONS		MATERIAL NO.		DOCUMENT NO.		SHEET NO.		
				SEE CHART		SD-52610-051		2 OF 5				
				THIS DRAWING CONTAINS INFORMATION THAT IS PROPRIETARY TO MOLEX INCORPORATED AND SHOULD NOT BE USED WITHOUT WRITTEN PERMISSION								

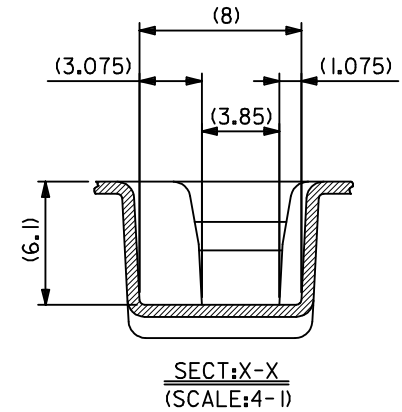
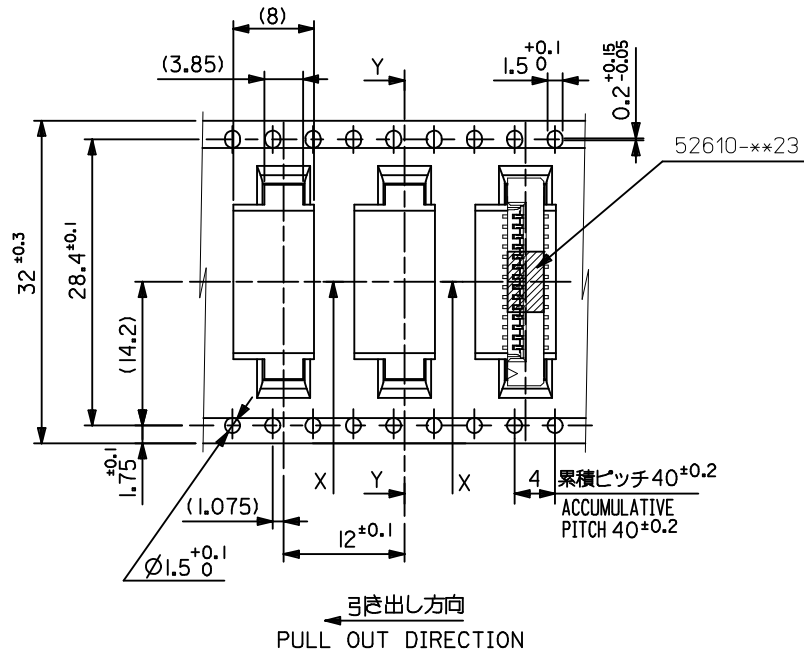
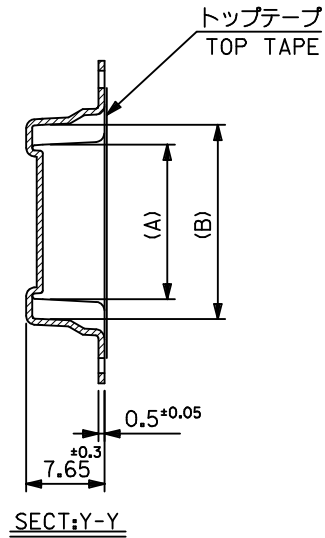

32	37.4	33.4	20.25	16.32	52610-1534	15
			19.25	15.32	52610-1434	14
			18.25	14.32	52610-1334	13
			17.25	13.32	52610-1234	12
キャリアテープ幅 CARRIER TAPE WIDTH	D	C	(B)	(A)	MATERIAL NO.	極数 CKT.

SEE SHEET 1 OF 5 EC NO: J2013-1003 DRWN:AISHII 2013/02/20 CHKD:KTAKAHASHI 2013/02/20 APPR:KMORIKAWA 2013/03/15	DESCRIPTION REV: 0	GENERAL TOLERANCES (UNLESS SPECIFIED)		DIMENSION STYLE MM ONLY		SCALE ---	DESIGN UNITS METRIC	THIRD ANGLE PROJECTION		
		10 UNDER	±0.3	DRAWN BY AISHII	DATE 2013/02/20	TITLE EMBOSS TAPE PACKAGED FOR 1.0 FPC CONN ZIF S/T HOUSING ASSY				
		10 OVER 30 UNDER	±0.25	CHECKED BY KTAKAHASHI	DATE 2013/02/20					
		30 OVER	±0.2	APPROVED BY KMORIKAWA	DATE 2013/03/15					
		ANGULAR ±3 °		DRAFT WHERE APPLICABLE MUST REMAIN WITHIN DIMENSIONS		MATERIAL NO. SEE CHART	DOCUMENT NO. SD-52610-051	SHEET NO. 3 OF 5		
THIS DRAWING CONTAINS INFORMATION THAT IS PROPRIETARY TO MOLEX INCORPORATED AND SHOULD NOT BE USED WITHOUT WRITTEN PERMISSION										

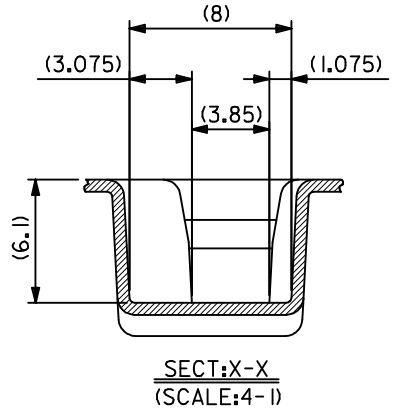
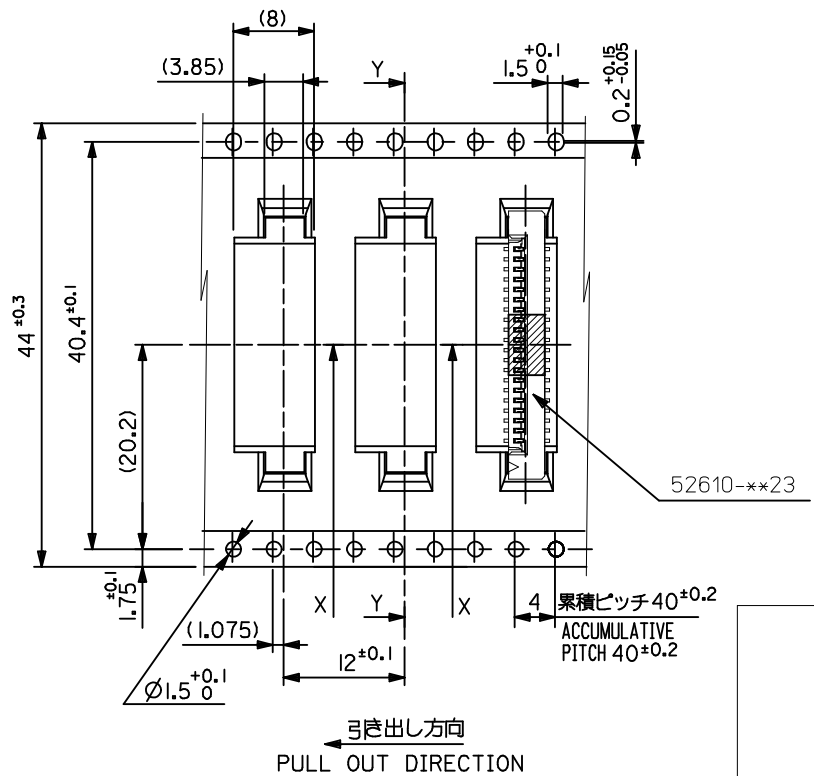
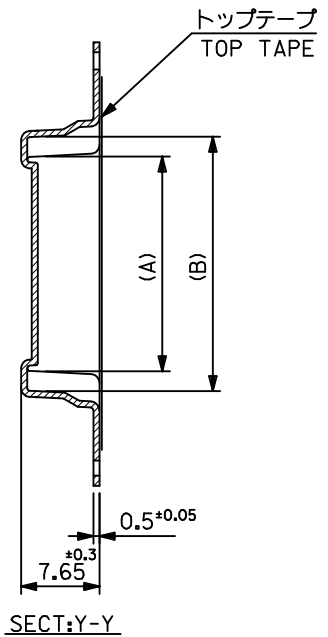

44	49.4	45.4	31.25	27.32	52610-2634	26
			30.25	26.32	52610-2534	25
			29.25	25.32	52610-2434	24
			28.25	24.32	52610-2334	23
			27.25	23.32	52610-2234	22
			26.25	22.32	52610-2134	21
			25.25	21.32	52610-2034	20
			24.25	20.32	52610-1934	19
			23.25	19.32	52610-1834	18
21.25	17.32	52610-1634	16			
キャリアテープ幅 CARRIER TAPE WIDTH	D	C	(B)	(A)	MATERIAL. NO.	極数 CKT.

SEE SHEET 1 OF 5 EC NO.: J2013-1003 DRW: AISHII 2013/02/20 CHKD: KTAHASHI 2013/02/20 APPR: KMORIKAWA 2013/03/15	DESCRIPTION REV: 0	GENERAL TOLERANCES (UNLESS SPECIFIED)		DIMENSION STYLE MM ONLY		SCALE ---		DESIGN UNITS METRIC		THIRD ANGLE PROJECTION	
		10 UNDER	±0.3	DRAWN BY AISHII	DATE 2013/02/20	TITLE EMBOSS TAPE PACKAGED FOR 1.0 FPC CONN ZIF S/T HOUSING ASSY <b>molex</b>					
		10 OVER 30 UNDER	±0.25	CHECKED BY KTAHASHI	DATE 2013/02/20						
		30 OVER	±0.2	APPROVED BY KMORIKAWA	DATE 2013/03/15						
		ANGULAR ±3 °		DRAFT WHERE APPLICABLE MUST REMAIN WITHIN DIMENSIONS		MATERIAL NO. SEE CHART		DOCUMENT NO. SD-52610-051		SHEET NO. 4 OF 5	
THIS DRAWING CONTAINS INFORMATION THAT IS PROPRIETARY TO MOLEX INCORPORATED AND SHOULD NOT BE USED WITHOUT WRITTEN PERMISSION											



## X-ON Electronics

Largest Supplier of Electrical and Electronic Components

*Click to view similar products for [FFC & FPC Connectors](#) category:*

*Click to view products by [Molex](#) manufacturer:*

Other Similar products are found below :

[HFW11R-1STE1H1LF](#) [FH29B-100S-0.2SHW\(99\)](#) [FA5S008HP1](#) [FH29B-120S-0.2SHW\(99\)](#) [FH29B-80S-0.2SHW\(99\)](#) [FHS-16](#) [FPH-2022G](#)  
[52610-1075](#) [52610-1275](#) [52610-1934](#) [XF3M\(1\)-1415-1B-R100](#) [501864-3091-TR225](#) [0525594033](#) [086210010340800](#) [086222026001800](#)  
[52271-2869-CUT-TAPE](#) [62674-201121DLF](#) [62684-36210E9ALF](#) [52610-1675](#) [52746-1671-TR250](#) [10051922-2810EHLF](#) [6-520415-9](#)  
[BD021-09A-A1-0350-0200-0550-LD](#) [SFV6R-1STE9HLF](#) [XF3M-2915-1B-R100](#) [1658549-1](#) [62674-221121ALF](#) [46214008010800](#)  
[046298003000883](#) [151660622](#) [842-816-2630-035](#) [AYF530665TA](#) [AYF351525](#) [046296011930846+](#) [AYF352325A](#) [046254020000800+](#)  
[FH19C-13S-0.5SH\(99\)](#) [FH39J-51S-0.3SHW\(99\)](#) [AYF355125A](#) [AYF530365TA](#) [FH29B-44S-0.2SHW\(99\)](#) [SFW5R-2STAE9LF](#) [AYF351125A](#)  
[AYF350725A](#) [62684-502100AHLF](#) [FH39-61S-0.3SHW\(99\)](#) [AYF414035A](#) [10064555-172520HLF](#) [AYF212335A](#) [504754-2500](#)