

BMR 453 PI series Intermediate Bus Converters
 Input 44-75 V, Output up to 60 A / 711 W

EN/LZT 146 444 R1C September 2011

© Ericsson AB

Key Features

- Industry standard Quarter-brick footprint
 57.9 x 36.8 x 24.5 mm (2.28 x 1.45 x 0.965 in)
- High efficiency, typ. 96.7% at 12.45 Vout half load
- 1500 Vdc input to output isolation
- Meets safety requirements according to IEC/EN/UL 60950-1
- MTBF 1.2 Mh

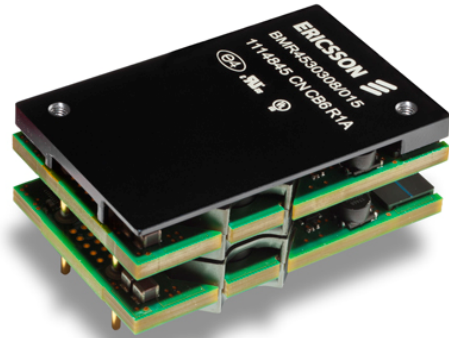

General Characteristics

- Output over voltage protection
- Input under voltage shutdown
- Over temperature protection
- Over current protection
- Remote control
- Highly automated manufacturing ensures quality
- ISO 9001/14001 certified supplier

Safety Approvals



Design for Environment



Meets requirements in high-temperature lead-free soldering processes.

Contents

Ordering Information	2
General Information	2
Safety Specification	3
Absolute Maximum Ratings	4
Electrical Specification	
12.45V, 60A / 711W	BMR 453 0108/014..... 5
EMC Specification	9
Operating Information	10
Thermal Consideration	12
Connections	13
Mechanical Information	14
Soldering Information	15
Delivery Information	15
Product Qualification Specification	16

BMR 453 PI series Intermediate Bus Converters
Input 44-75 V, Output up to 60 A / 711 W

EN/LZT 146 444 R1C September 2011

© Ericsson AB

Ordering Information

Product program	Output
BMR4530108/014	12.45 V / 60 A, 711 W

Product Number and Packaging

BMR453	n ₁	n ₂	n ₃	n ₄	/	n ₅	n ₆	n ₇
Mechanical pin option	x				/			
Mechanical option		x			/			
Hardware option			x	x	/			
Configuration file					/	x	x	x

Optional designation	Description
n ₁	0 = Standard pin length 5.33 mm
n ₂	1 = Baseplate 2 = Baseplate with GND-pin(Pin 3 only included with this ordering option)
n ₃ n ₄	08 = 8.1-13.2 Vout Without digital interface
n ₅ n ₆ n ₇	014 = 12.45 V with 0.6 V droop load sharing function configuration
Packaging	20 converters/tray/box PE foam dissipative

Example: Product number BMR4530108/14 equals a Through hole mount lead length 5.33 mm, baseplate, without digital interface with 12.45 V standard configuration variant.
For application specific configurations contact your local Ericsson Power Modules sales representative.

General Information

Reliability

The failure rate (λ) and mean time between failures (MTBF= 1/ λ) is calculated at max output power and an operating ambient temperature (T_A) of +40°C. Ericsson Power Modules uses Telcordia SR-332 Issue 2 Method 1 to calculate the mean steady-state failure rate and standard deviation (σ).

Telcordia SR-332 Issue 2 also provides techniques to estimate the upper confidence levels of failure rates based on the mean and standard deviation.

Mean steady-state failure rate, λ	Std. deviation, σ
804 nFailures/h	61 nFailures/h

MTBF (mean value) for the BMR453 series = 1.2 Mh.
MTBF at 90% confidence level = 1.0 Mh

Compatibility with RoHS requirements

The products are compatible with the relevant clauses and requirements of the RoHS directive 2002/95/EC and have a maximum concentration value of 0.1% by weight in homogeneous materials for lead, mercury, hexavalent chromium, PBB and PBDE and of 0.01% by weight in homogeneous materials for cadmium.

Exemptions in the RoHS directive utilized in Ericsson Power Modules products are found in the Statement of Compliance document.

Ericsson Power Modules fulfills and will continuously fulfill all its obligations under regulation (EC) No 1907/2006 concerning the registration, evaluation, authorization and restriction of chemicals (REACH) as they enter into force and is through product materials declarations preparing for the obligations to communicate information on substances in the products.

Quality Statement

The products are designed and manufactured in an industrial environment where quality systems and methods like ISO 9000, Six Sigma, and SPC are intensively in use to boost the continuous improvements strategy. Infant mortality or early failures in the products are screened out and they are subjected to an ATE-based final test. Conservative design rules, design reviews and product qualifications, plus the high competence of an engaged work force, contribute to the high quality of the products.

Warranty

Warranty period and conditions are defined in Ericsson Power Modules General Terms and Conditions of Sale.

Limitation of Liability

Ericsson Power Modules does not make any other warranties, expressed or implied including any warranty of merchantability or fitness for a particular purpose (including, but not limited to, use in life support applications, where malfunctions of product can cause injury to a person's health or life).

© Ericsson AB 2011

The information and specifications in this technical specification is believed to be correct at the time of publication. However, no liability is accepted for inaccuracies, printing errors or for any consequences thereof. Ericsson AB reserves the right to change the contents of this technical specification at any time without prior notice.

BMR 453 PI series Intermediate Bus Converters
Input 44-75 V, Output up to 60 A / 711 W

EN/LZT 146 444 R1C September 2011

© Ericsson AB

Safety Specification**General information**

Ericsson Power Modules DC/DC converters and DC/DC regulators are designed in accordance with safety standards IEC/EN/UL 60950-1 *Safety of Information Technology Equipment*.

IEC/EN/UL 60950-1 contains requirements to prevent injury or damage due to the following hazards:

- Electrical shock
- Energy hazards
- Fire
- Mechanical and heat hazards
- Radiation hazards
- Chemical hazards

On-board DC/DC converters and DC/DC regulators are defined as component power supplies. As components they cannot fully comply with the provisions of any safety requirements without "Conditions of Acceptability". Clearance between conductors and between conductive parts of the component power supply and conductors on the board in the final product must meet the applicable safety requirements. Certain conditions of acceptability apply for component power supplies with limited stand-off (see Mechanical Information for further information). It is the responsibility of the installer to ensure that the final product housing these components complies with the requirements of all applicable safety standards and regulations for the final product.

Component power supplies for general use should comply with the requirements in IEC 60950-1, EN 60950-1 and UL 60950-1 *Safety of Information Technology Equipment*. There are other more product related standards, e.g. IEEE 802.3 *CSMA/CD (Ethernet) Access Method*, and ETS-300132-2 *Power supply interface at the input to telecommunications equipment, operated by direct current (dc)*, but all of these standards are based on IEC/EN/UL 60950-1 with regards to safety. Ericsson Power Modules DC/DC converters and DC/DC regulators are UL 60950-1 recognized and certified in accordance with EN 60950-1.

The flammability rating for all construction parts of the products meet requirements for V-0 class material according to IEC 60695-11-10, *Fire hazard testing, test flames* – 50 W horizontal and vertical flame test methods.

The products should be installed in the end-use equipment, in accordance with the requirements of the ultimate application. Normally the output of the DC/DC converter is considered as SELV (Safety Extra Low Voltage) and the input source must be isolated by minimum Double or Reinforced Insulation from the primary circuit (AC mains) in accordance with IEC/EN/UL 60950-1.

Isolated DC/DC converters

It is recommended that a slow blow fuse is to be used at the input of each DC/DC converter. If an input filter is used in the circuit the fuse should be placed in front of the input filter.

In the rare event of a component problem that imposes a short circuit on the input source, this fuse will provide the following functions:

- Isolate the fault from the input power source so as not to affect the operation of other parts of the system.
- Protect the distribution wiring from excessive current and power loss thus preventing hazardous overheating.

The galvanic isolation is verified in an electric strength test. The test voltage (V_{iso}) between input and output is 1500 Vdc or 2250 Vdc (refer to product specification).

24 V DC systems

The input voltage to the DC/DC converter is SELV (Safety Extra Low Voltage) and the output remains SELV under normal and abnormal operating conditions.

48 and 60 V DC systems

If the input voltage to the DC/DC converter is 75 Vdc or less, then the output remains SELV (Safety Extra Low Voltage) under normal and abnormal operating conditions.

Single fault testing in the input power supply circuit should be performed with the DC/DC converter connected to demonstrate that the input voltage does not exceed 75 Vdc.

If the input power source circuit is a DC power system, the source may be treated as a TNV-2 circuit and testing has demonstrated compliance with SELV limits in accordance with IEC/EN/UL60950-1.

Non-isolated DC/DC regulators

The input voltage to the DC/DC regulator is SELV (Safety Extra Low Voltage) and the output remains SELV under normal and abnormal operating conditions.

BMR 453 PI series Intermediate Bus Converters
 Input 44-75 V, Output up to 60 A / 711 W

EN/LZT 146 444 R1C September 2011

© Ericsson AB

Absolute Maximum Ratings

Characteristics		min	typ	max	Unit
T_{P1}	Operating Temperature (see Thermal Consideration section)	-40		+125	°C
T_S	Storage temperature	-55		+125	°C
V_I	Input voltage	-0.5		+80	V
V_{iso}	Isolation voltage (input to output test voltage)			1500	Vdc
V_{tr}	Input voltage transient (Tp 100ms)			100	V
V_{RC}	Remote Control pin voltage (see Operating Information section)	Positive logic option		18	V
		Negative logic option	-0.3	18	V
V	SALERT, CTRL, SYNC, SCL, SDA, SA(0,1)	-0.3		3.6	V

Stress in excess of Absolute Maximum Ratings may cause permanent damage. Absolute Maximum Ratings, sometimes referred to as no destruction limits, are normally tested with one parameter at a time exceeding the limits in the Electrical Specification. If exposed to stress above these limits, function and performance may degrade in an unspecified manner.

Fundamental Circuit Diagram

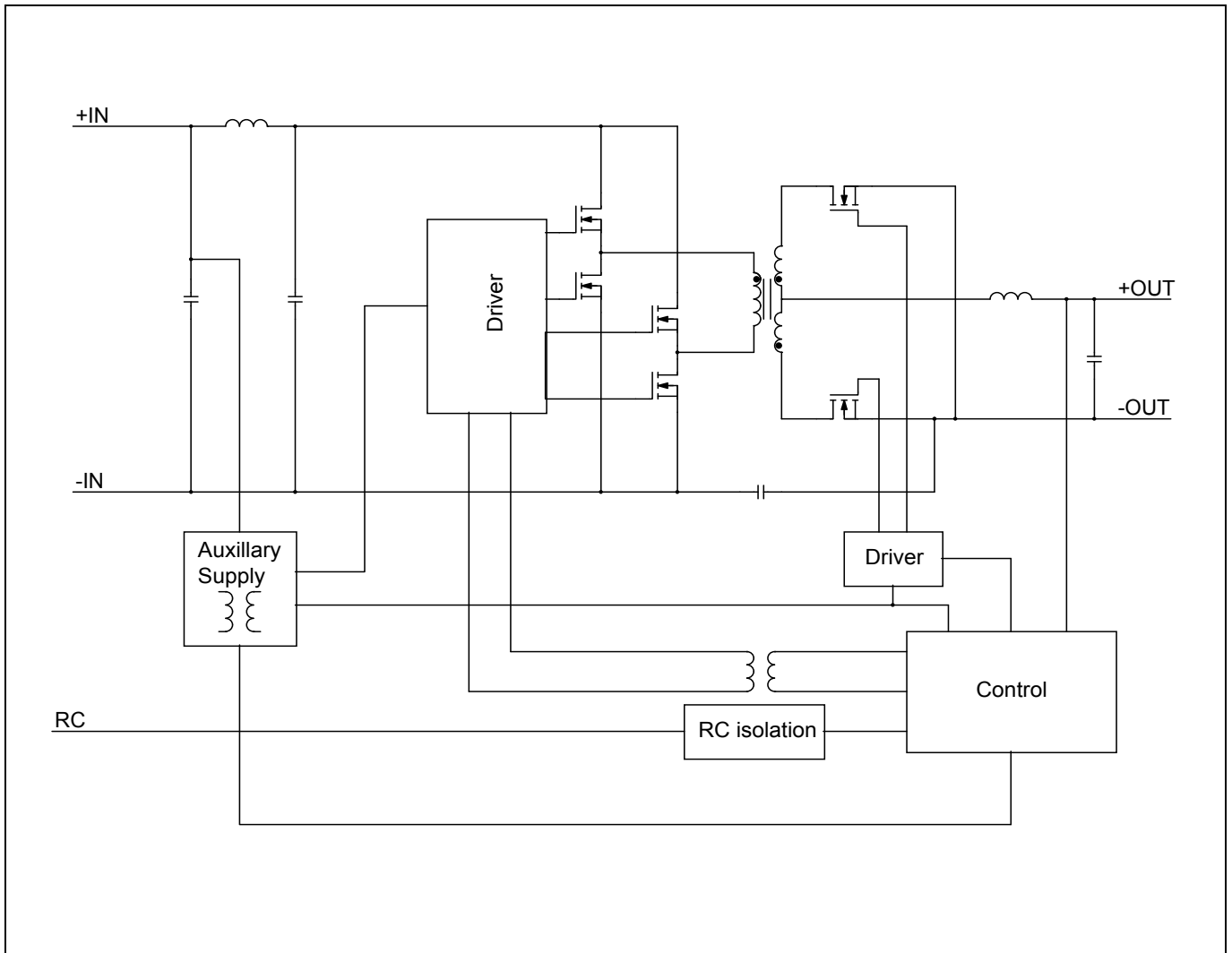

BMR 453 PI series Intermediate Bus Converters
 Input 44-75 V, Output up to 60 A / 711 W

EN/LZT 146 444 R1C September 2011

© Ericsson AB

Electrical Specification
12.45 V, 60 A / 711 W
BMR 453 0208/014
 $T_{P1} = -40$ to $+90^{\circ}\text{C}$, $V_I = 44$ to 75 V, unless otherwise specified under Conditions.

 Typical values given at: $T_{P1} = +25^{\circ}\text{C}$, $V_I = 53$ V, max I_O , unless otherwise specified under Conditions.

 Additional $C_{in} = C_{out} = 220$ μF . See Operating Information section for selection of capacitor types.

Characteristics		Conditions	min	typ	max	Unit
V_I	Input voltage range		44		75	V
V_{loff}	Turn-off input voltage	Decreasing input voltage	32.9	34.1	35.0	V
V_{lon}	Turn-on input voltage	Increasing input voltage	33.8	34.6	36.1	V
C_I	Internal input capacitance			35.2		μF
P_O	Output power		0		711	W
η	Efficiency	50% of max I_O		96.7		%
		max I_O		95.8		
		50% of max I_O , $V_I = 44$ V		96.9		
		max I_O , $V_I = 44$ V		95.8		
P_d	Power Dissipation	max I_O		31.2		W
P_{li}	Input idling power	$I_O = 0$ A, $V_I = 53$ V		4.8		W
P_{RC}	Input standby power	$V_I = 53$ V (turned off with RC)		0.32		W
f_s	Switching frequency	0-100 % of max I_O	133	140	145	kHz

V_{Oi}	Output voltage initial setting and accuracy	$T_{P1} = +25^{\circ}\text{C}$, $V_I = 53$ V, $I_O = 60$ A	12.40	12.42	12.43	V
V_O	Output voltage tolerance band	0-100% of max I_O	11.70		12.46	V
	Idling voltage	$I_O = 0$ A	12.4		12.4	V
	Line regulation	max I_O		20.0	21.0	mV
	Load regulation	$V_I = 53$ V, 1-100% of max I_O		510.2	661.0	mV
V_{tr}	Load transient voltage deviation	$V_I = 53$ V, Load step 25-75-25% of max I_O , $di/dt = 1$ A/ μs see Note 1		± 320	± 400	mV
t_{tr}	Load transient recovery time			30		μs
t_r	Ramp-up time (from 10-90% of V_{Oi})	10-100% of max I_O	8.3	20.7	30.9	ms
t_s	Start-up time (from V_I connection to 90% of V_{Oi})		140.0	143.2	146.0	ms
t_f	V_I shut-down fall time (from V_I off to 10% of V_O)	max I_O		0.8		ms
t_{RC}	RC start-up time	max I_O		55.3		ms
	RC shut-down fall time (from RC off to 10% of V_O)	max I_O $I_O = 0$ A		3.3 7.3		ms s
I_O	Output current		0		60	A
I_{lim}	Current limit threshold	$V_O = 10.8$ V	72.1	75	75	A
I_{sc}	Short circuit current	$T_{P1} = 25^{\circ}\text{C}$, see Note 2		77.5	84.9	A
C_{out}	Recommended Capacitive Load	$T_{P1} = 25^{\circ}\text{C}$	0.2	6.6	12	μF
V_{Oac}	Output ripple & noise, see Note3	See ripple & noise section, V_{Oi}		73.1	147.5	mVp-p
OVP	Over voltage protection	$T_{P1} = +25^{\circ}\text{C}$, $V_I = 53$ V, $I_O = 1$ A		15.8		V
RC	Sink current, see Note 4	See operating information			1.4	mA
	Trigger level	See operating information			1	V

 Note 1: $C_o = 6600$ μF OS-CON, 100 μF ceramic capacitor

Note 2: Applying load until the output voltage lower than 0.5V

Note 3: Low ESR-value

Note 4: Sink current drawn by external device connected to the RC pin. Minimum sink current required to guarantee activated RC function.

BMR 453 PI series Intermediate Bus Converters
 Input 44-75 V, Output up to 60 A / 711 W

EN/LZT 146 444 R1C September 2011

© Ericsson AB

Typical Characteristics
12.45 V, 60 A / 711 W

BMR 453 0208/014

Efficiency

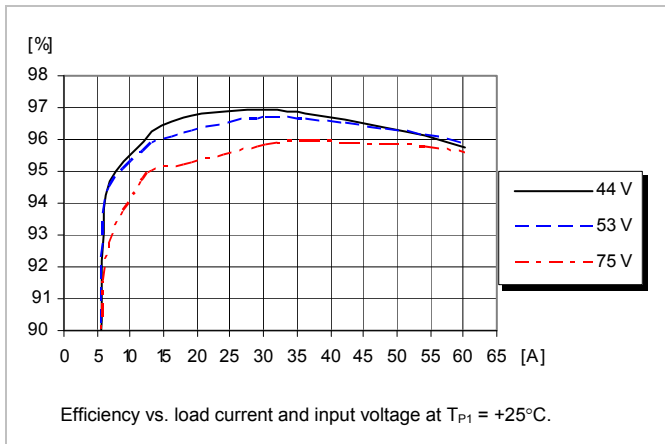

Power Dissipation

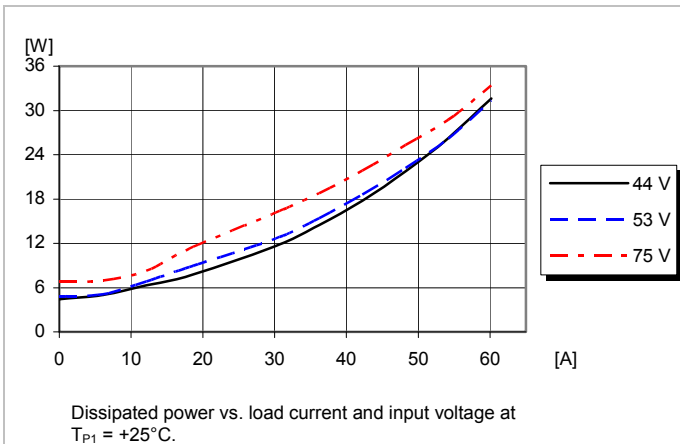

Output Characteristics

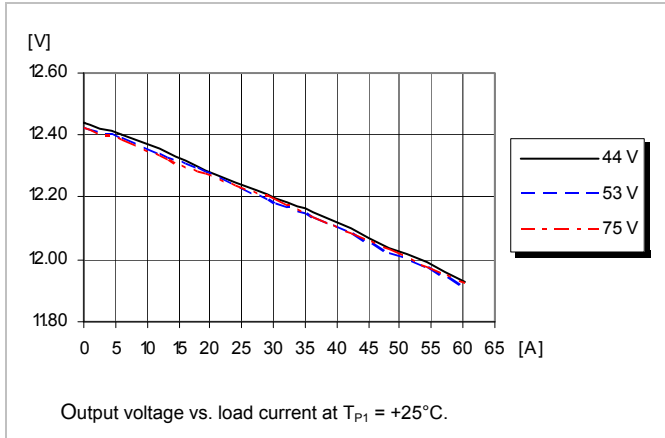

Current Limit Characteristics

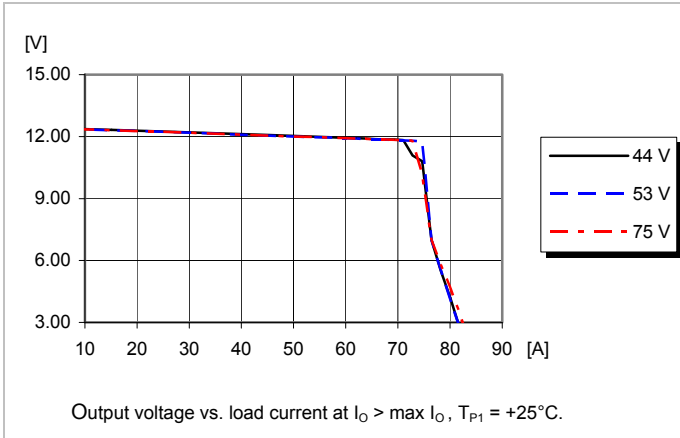

BMR 453 PI series Intermediate Bus Converters
 Input 44-75 V, Output up to 60 A / 711 W

EN/LZT 146 444 R1C September 2011

© Ericsson AB

Typical Characteristics
12.45 V, 60 A / 711 W

BMR 453 0208/014

Start-up

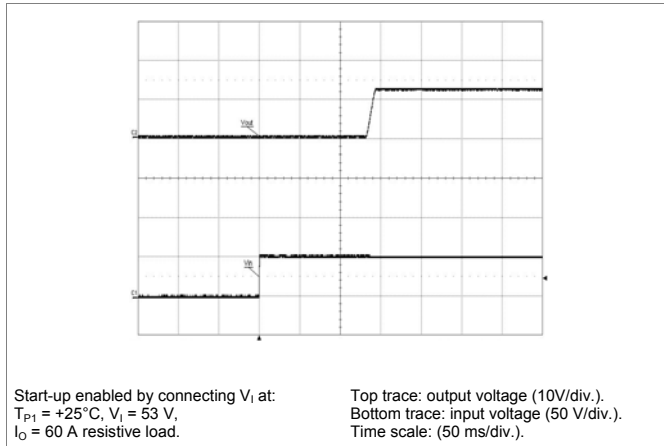

Shut-down

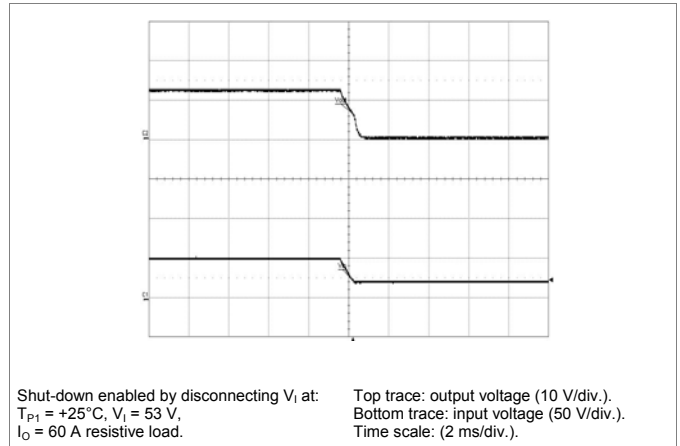

Output Ripple & Noise

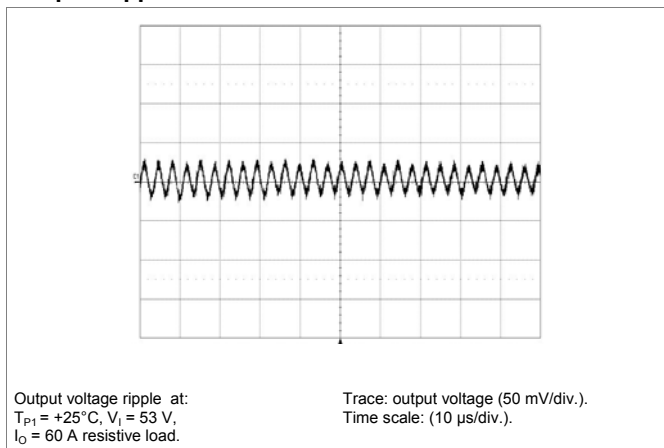

Output Load Transient Response

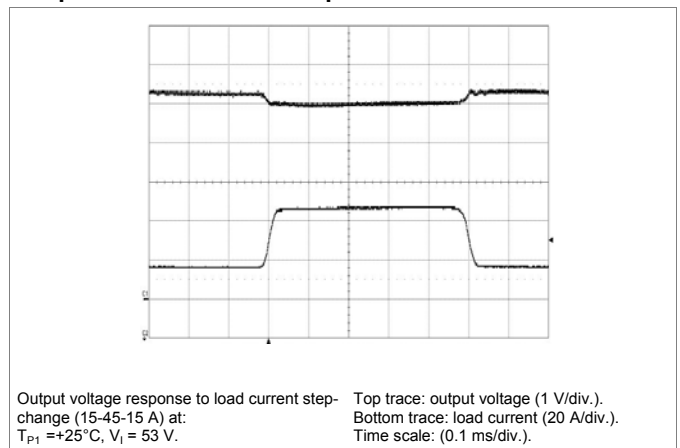

BMR 453 PI series Intermediate Bus Converters
 Input 44-75 V, Output up to 60 A / 711 W

EN/LZT 146 444 R1C September 2011

© Ericsson AB

Electrical Specification
12.45 V, 60 A / 711 W

BMR 453 0208/014

Output Current Derating – Base plate

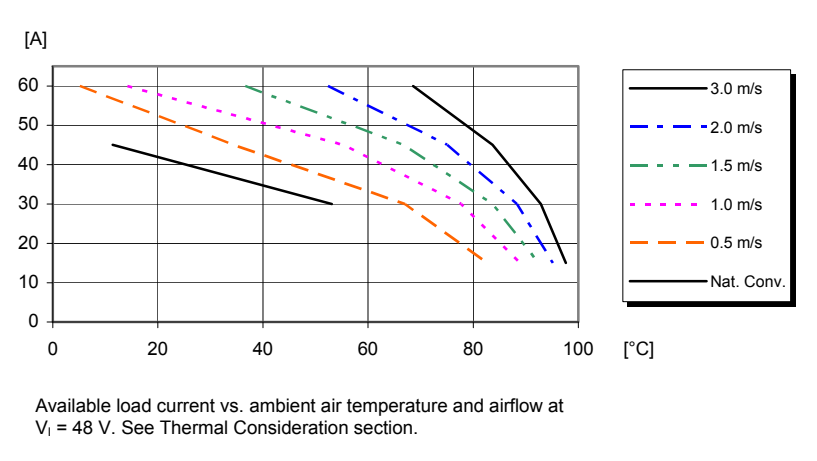

Thermal Resistance – Base plate

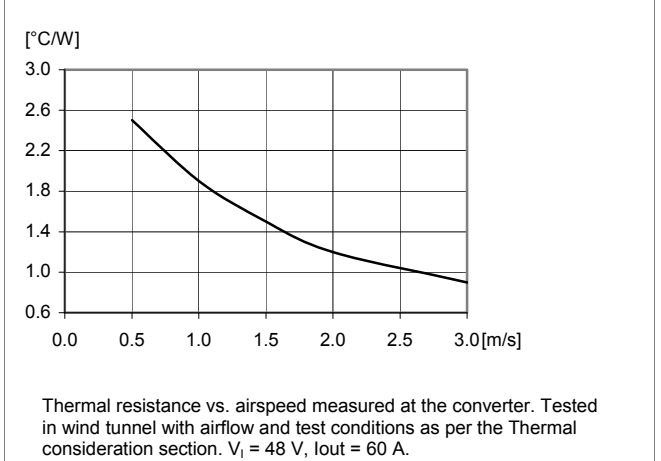

Output Current Derating – Base plate with heat sink

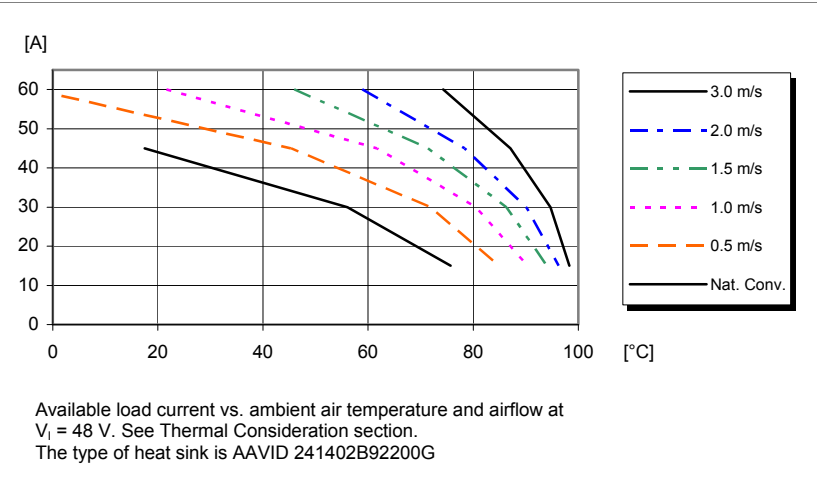

Thermal Resistance – Base plate with heat sink

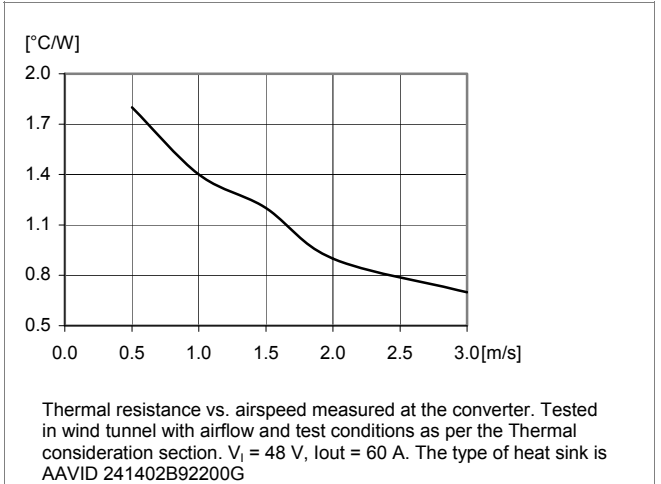

BMR 453 PI series Intermediate Bus Converters
 Input 44-75 V, Output up to 60 A / 711 W

EN/LZT 146 444 R1C September 2011

© Ericsson AB

EMC Specification

Conducted EMI measured according to EN55022, CISPR 22 and FCC part 15J (see test set-up). See Design Note 009 for detailed information. The fundamental switching frequency is 140KHz for BMR 453 at $V_I = 53 V$, max I_O .

Conducted EMI Input terminal value (typ)

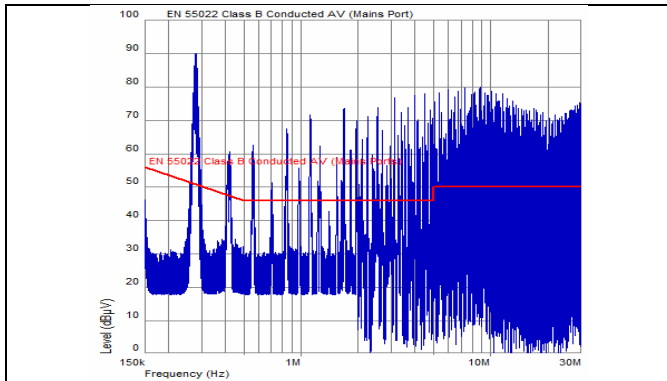

EMI without filter

Optional external filter for class B

Suggested external input filter in order to meet class B in EN 55022, CISPR 22 and FCC part 15J.

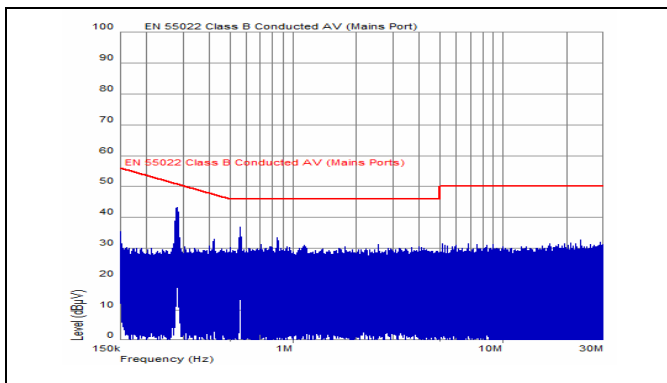
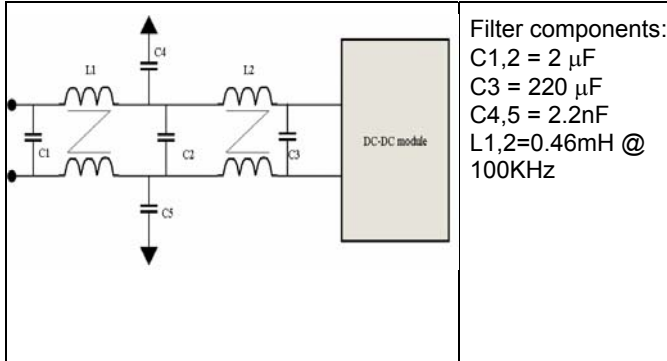

EMI with filter

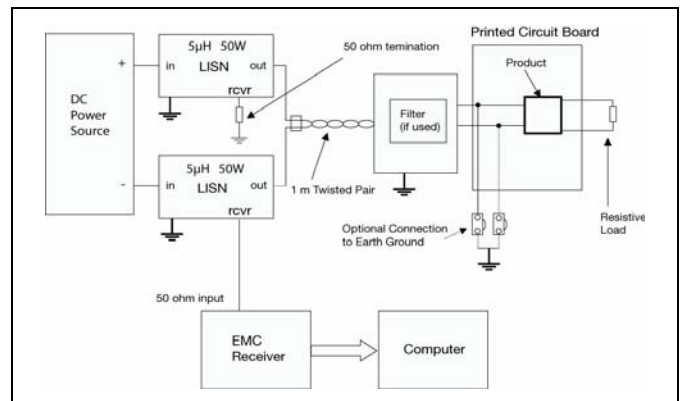

Test set-up

Layout recommendations

The radiated EMI performance of the product will depend on the PWB layout and ground layer design. It is also important to consider the stand-off of the product. If a ground layer is used, it should be connected to the output of the product and the equipment ground or chassis.

A ground layer will increase the stray capacitance in the PWB and improve the high frequency EMC performance.

Output ripple and noise

Output ripple and noise measured according to figure below. See Design Note 022 for detailed information.

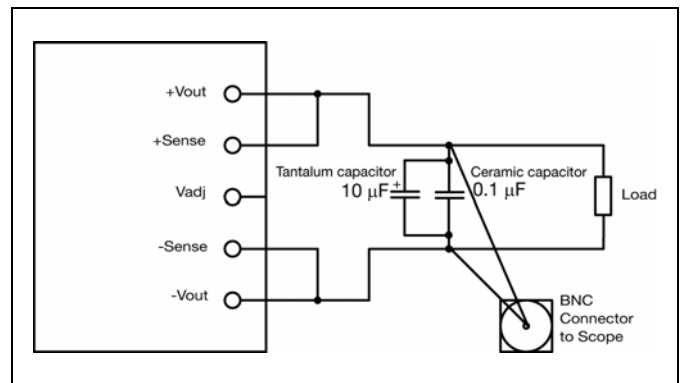

Output ripple and noise test setup

BMR 453 PI series Intermediate Bus Converters
Input 44-75 V, Output up to 60 A / 711 W

EN/LZT 146 444 R1C September 2011

© Ericsson AB

Operating information

Input Voltage

The input voltage range 45 to 53 Vdc meets the requirements of the European Telecom Standard ETS 300 132-2 for normal input voltage range in -50.0 to -72 V. At input voltages exceeding 75 V, the power loss will be higher than at normal input voltage and T_{P1} must be limited to absolute max +125°C. The absolute maximum continuous input voltage is 80 Vdc.

Turn-off Input Voltage

The product monitors the input voltage and will turn on and turn off at predetermined levels. The minimum hysteresis between turn on and turn off input voltage is 1 V.

Remote Control (RC)

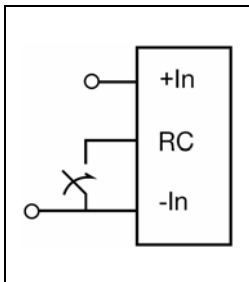

The product is fitted with a remote control function referenced to the primary negative input connection (-In). The RC function allows the product to be turned on/off by an external device like a semiconductor or mechanical switch. The RC pin has an internal pull up resistor to internal voltage reference 18V.

The external device must provide a minimum required sink current to guarantee a maximum voltage on the RC pin (see Electrical characteristics table)

The standard product is provided with “negative logic” RC and will be off until the RC pin is connected to the -In. To turn off the product the RC pin should be left open, or connected to a voltage higher than 13 V referenced to -In. In situations where it is desired to have the product to power up automatically without the need for control signals or a switch, the RC pin can be wired directly to -In.

Input and Output Impedance

The impedance of both the input source and the load will interact with the impedance of the product. It is important that the input source has low characteristic impedance. The products are designed for stable operation without external capacitors connected to the input or output. The performance in some applications can be enhanced by addition of external capacitance as described under External Decoupling Capacitors. If the input voltage source contains significant inductance, the addition of a 22 - 100 μ F capacitor across the input of the product will ensure stable operation. The capacitor is not required when powering the product from an input source with an inductance below 10 μ H. The minimum required capacitance value depends on the output power and the input voltage. The higher output

power the higher input capacitance is needed.

External Decoupling Capacitors

When powering loads with significant dynamic current requirements, the voltage regulation at the point of load can be improved by addition of decoupling capacitors at the load. The most effective technique is to locate low ESR ceramic and electrolytic capacitors as close to the load as possible, using several parallel capacitors to lower the effective ESR. The ceramic capacitors will handle high-frequency dynamic load changes while the electrolytic capacitors are used to handle low frequency dynamic load changes. Ceramic capacitors will also reduce any high frequency noise at the load. It is equally important to use low resistance and low inductance PWB layouts and cabling.

External decoupling capacitors will become part of the product’s control loop. The control loop is optimized for a wide range of external capacitance and the maximum recommended value that could be used without any additional analysis is found in the Electrical specification. The ESR of the capacitors is a very important parameter. Stable operation is guaranteed with a verified ESR value of >10 m Ω across the output connections. For further information please contact your local Ericsson Power Modules representative.

Soft-start Power Up

The soft-start control introduces a time-delay (default setting 40 ms) before allowing the output voltage to rise. The default rise time of the ramp up is 10 ms. Power-up is hence completed within 50 ms in default configuration using remote control. When starting by applying input voltage the control circuit boot-up time adds an additional 140 ms delay.

Temperature Protection (OTP)

The product is protected from thermal overload by an internal temperature shutdown protection. When T_{P1} as defined in thermal consideration section is exceeded the product will shut down. The product will make continuous attempts to start up (non-latching mode) and resume normal operation automatically when the temperature has dropped below the temperature threshold. The hysteresis is defined in general electrical specification.

Note: the fault response “continue without interruption” may cause permanent damage of the product.

Over Voltage Protection (OVP)

The product has output over voltage protection that will shut down the product in over voltage conditions.

Over Current Protection (OCP)

The product includes current limiting circuitry for protection at continuous overload. The output voltage will decrease towards zero for output currents in excess of max output

BMR 453 PI series Intermediate Bus Converters
Input 44-75 V, Output up to 60 A / 711 W

EN/LZT 146 444 R1C September 2011

© Ericsson AB

current (max I_o). The product will resume normal operation after removal of the overload. The load distribution should be designed for the maximum output short circuit current specified.

Fault protection recovery

If one of the two modules exceeds the OVP, OCP or OTP level, the module might turn off depends on its pre-set fault response action, and the other module might not handle more current than its max capability, that will lead to both modules can not recover until the protection trig condition removed, to secure a normal operation, both modules need a reset after the fault condition removed.

Pre-bias Start-up

The product has a Pre-bias start up functionality and will not sink current during start up if a pre-bias source is present at the output terminals.

Input Transient

The products have limited ability to react on sudden input voltage changes. The module can have an output voltage deviation of 2 V when input step is applied (45 V to 53 V). This is tested with a slew rate of 0.1 V/us on the input voltage change and minimum output capacitance 100 uF. Increasing the output capacitance will improve the result.

BMR 453 PI series Intermediate Bus Converters
Input 44-75 V, Output up to 60 A / 711 W

EN/LZT 146 444 R1C September 2011

© Ericsson AB

Thermal Consideration

General

The product is designed to operate in different thermal environments and sufficient cooling must be provided to ensure reliable operation.

For products mounted on a PWB without a heat sink attached, cooling is achieved mainly by conduction, from the pins to the host board, and convection, which is dependant on the airflow across the product. Increased airflow enhances the cooling of the product. The Output Current Derating graph found in the Output section for each model provides the available output current vs. ambient air temperature and air velocity at $V_I=53V$.

The product is tested on a 254 x 254 mm, 35 μ m (1 oz), 16-layer test board mounted vertically in a wind tunnel with a cross-section of 608 x 203 mm.

measurement points may vary with different thermal design and topology. Temperatures above maximum T_{P1} , measured at the reference point P1 are not allowed and may cause permanent damage.

P1	Upper PCB (close to baseplate) bottom side (away from base plate)	$T_{P1}=125^\circ\text{C}$
P2	Upper PCB Optical coupler	$T_{P2}=110^\circ\text{C}$
P3	Lower PCB control IC	$T_{P3}=120^\circ\text{C}$
P4	Base plate	$T_{P4}=120^\circ\text{C}$

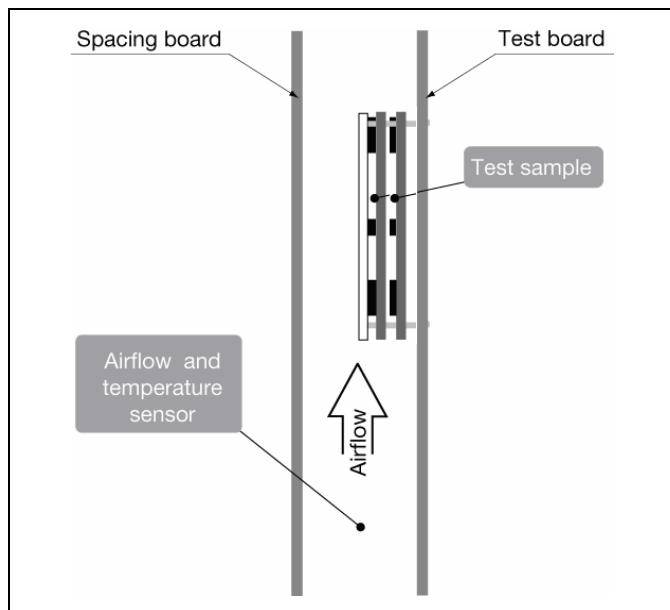
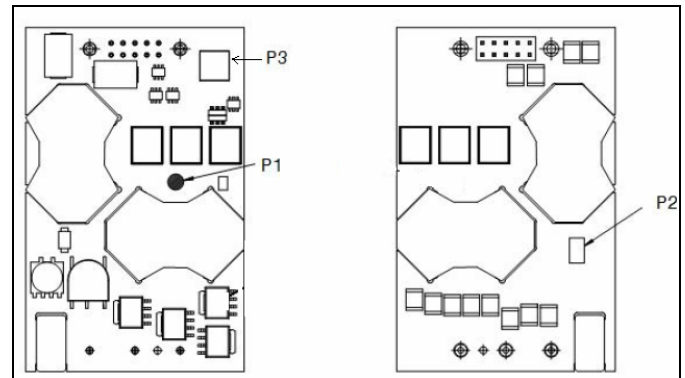

Definition of product operating temperature under forced air colling

The product operating temperature is used to monitor the temperature of the product, and proper thermal conditions can be verified by measuring the temperature at positions (P1, P2, P3 and P4). The temperature at these positions (T_{P1} , T_{P2} , T_{P3} , T_{P4}) should not exceed the maximum temperatures in the table below. The number of

Ambient Temperature Calculation

For products with base plate the maximum allowed ambient temperature can be calculated by using the thermal resistance.

1. The power loss is calculated by using the formula $((1/\eta) - 1) \times \text{output power} = \text{power losses (Pd)}$.
 η = efficiency of product. E.g. 95% = 0.95
2. Find the thermal resistance (R_{th}) in the Thermal Resistance graph found in the Output section for each model. **Note that the thermal resistance can be significantly reduced if a heat sink is mounted on the top of the base plate.**

Calculate the temperature increase (ΔT).

$$\Delta T = R_{th} \times P_d$$

3. Max allowed ambient temperature is:
 $\text{Max } T_{P1} - \Delta T$.

E.g. BMR 453 5100/001 at 2 m/s:

1. $((\frac{1}{0.944}) - 1) \times 396\text{ W} = 23.5\text{ W}$
2. $23.5\text{ W} \times 3.1^\circ\text{C/W} = 73^\circ\text{C}$
3. $125^\circ\text{C} - 73^\circ\text{C} = \text{max ambient temperature is } 52^\circ\text{C}$

The actual temperature will be dependent on several factors such as the PWB size, number of layers and direction of airflow.

BMR 453 PI series Intermediate Bus Converters
 Input 44-75 V, Output up to 60 A / 711 W

EN/LZT 146 444 R1C September 2011

© Ericsson AB

Connections (Top view)

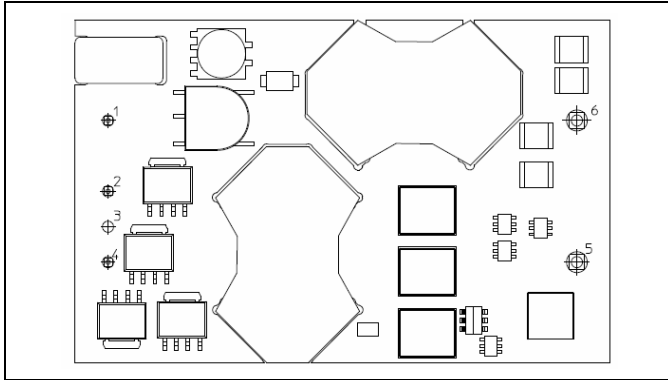

Pin	Designation	Function
1	+In	Positive input
2	RC	Remote control
3	Case	Connection to case(Optional; see Ground Pin ordering option)
4	-In	Negative input
5	-Out	Negative output
6	+Out	Positive output

BMR 453 PI series Intermediate Bus Converters
 Input 44-75 V, Output up to 60 A / 711 W

EN/LZT 146 444 R1C September 2011

© Ericsson AB

Mechanical Information – Hole mount – Stacker-Base plate GND version (24.5mm)

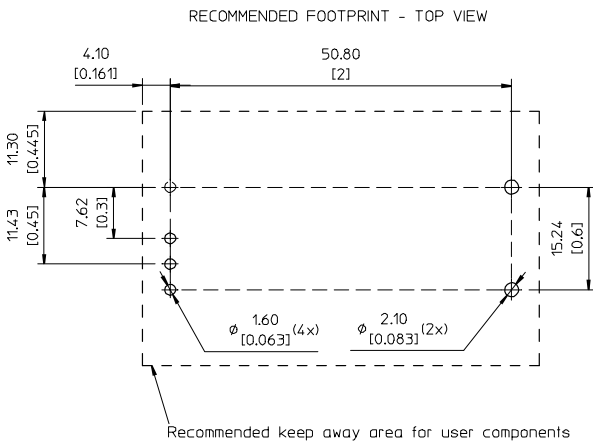
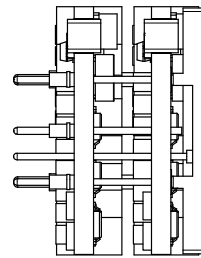
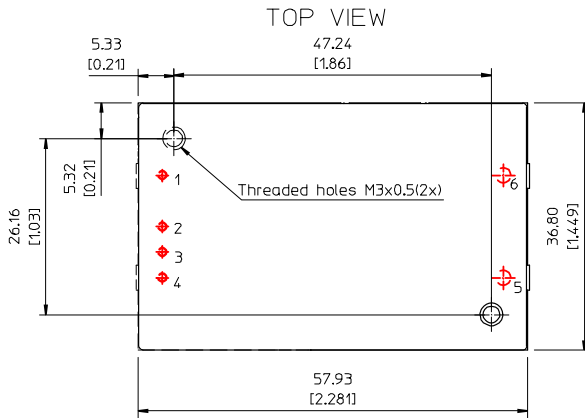
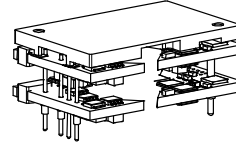
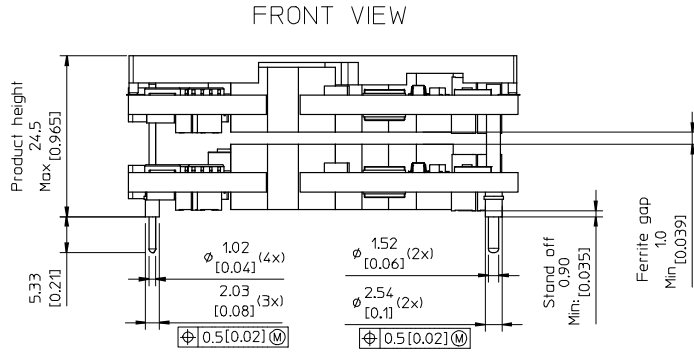

Case:
 Material: Aluminium
 - For screw attachment apply mounting torque of max 0.44 Nm(3.9 lbf in).
 - M3 screws must not protrude more than 2.4 [0.095] into the base plate

Pins:
 Material: copper alloy
 Plating: 0.14µm Gold over 2µNickel
 Pin3 is optional and only used for base plate connection

Weight: typical 110 g
 All dimensions in mm [inch].
 Tolerances unless specified
 x.x mm ±0.50 mm [0.02], x.xx mm ±0.25 mm [0.01]
 (not applied on footprint or typical values)



All component placements – whether shown as physical components or symbolical outline – are for reference only and are subject to change throughout the product's life cycle, unless explicitly described and dimensioned in this drawing.

BMR 453 PI series Intermediate Bus Converters
 Input 44-75 V, Output up to 60 A / 711 W

EN/LZT 146 444 R1C September 2011

© Ericsson AB

Soldering Information – Hole Mounting

The hole mounted product is intended for plated through hole mounting by wave or manual soldering. The pin temperature is specified to maximum to 270°C for maximum 10 seconds.

A maximum preheat rate of 4°C/s and maximum preheat temperature of 150°C is suggested. When soldering by hand, care should be taken to avoid direct contact between the hot soldering iron tip and the pins for more than a few seconds in order to prevent overheating.

A no-clean flux is recommended to avoid entrapment of cleaning fluids in cavities inside the product or between the product and the host board. The cleaning residues may affect long time reliability and isolation voltage.

Delivery Package Information – Hole Mount Version

The products are delivered in antistatic trays.

Tray Specifications	
Material	PE Foam
Surface resistance	$10^5 < \text{Ohm/square} < 10^{12}$
Bakability	The trays are not bakeable
Tray capacity	20 converters/tray
Box capacity	20 products (1 full tray/box)
Weight	Product – Stacker option 2460 g full tray, 260 g empty tray

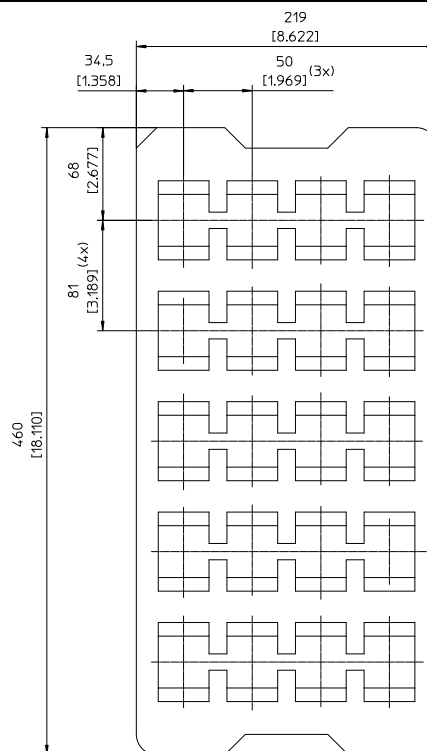

BMR 453 PI series Intermediate Bus Converters
 Input 44-75 V, Output up to 60 A / 711 W

EN/LZT 146 444 R1C September 2011

© Ericsson AB

Product Qualification Specification

Characteristics			
External visual inspection	IPC-A-610		
Change of temperature (Temperature cycling)	IEC 60068-2-14 Na	Temperature range Number of cycles Dwell/transfer time	-40 to 100°C 1000 15 min/0-1 min
Cold (in operation)	IEC 60068-2-1 Ad	Temperature T _A Duration	-45°C 72 h
Damp heat	IEC 60068-2-67 Cy	Temperature Humidity Duration	85°C 85 % RH 1000 hours
Dry heat	IEC 60068-2-2 Bd	Temperature Duration	125°C 1000 h
Electrostatic discharge susceptibility	IEC 61340-3-1, JESD 22-A114 IEC 61340-3-2, JESD 22-A115	Human body model (HBM) Machine Model (MM)	Class 2, 2000 V Class 3, 200 V
Immersion in cleaning solvents	IEC 60068-2-45 XA, method 2	Water Glycol ether Isopropyl alcohol	55°C 35°C 35°C
Mechanical shock	IEC 60068-2-27 Ea	Peak acceleration Duration	100 g 6 ms
Moisture reflow sensitivity ¹	J-STD-020C	Level 1 (SnPb-eutectic) Level 3 (Pb Free)	225°C 260°C
Operational life test	MIL-STD-202G, method 108A	Duration	1000 h
Resistance to soldering heat ²	IEC 60068-2-20 Tb, method 1A	Solder temperature Duration	270°C 10-13 s
Robustness of terminations	IEC 60068-2-21 Test Ua1 IEC 60068-2-21 Test Ue1	Through hole mount products Surface mount products	All leads All leads
Solderability	IEC 60068-2-58 test Td ¹	Preconditioning Temperature, SnPb Eutectic Temperature, Pb-free	150°C dry bake 16 h 215°C 235°C
	IEC 60068-2-20 test Ta ²	Preconditioning Temperature, SnPb Eutectic Temperature, Pb-free	Steam ageing 235°C 245°C
Vibration, broad band random	IEC 60068-2-64 Fh, method 1	Frequency Spectral density Duration	10 to 500 Hz 0.07 g ² /Hz 10 min in each direction

Notes
¹ Only for products intended for reflow soldering (surface mount products)

² Only for products intended for wave soldering (plated through hole products)

X-ON Electronics

Largest Supplier of Electrical and Electronic Components

Click to view similar products for [flex manufacturer](#):

Other Similar products are found below :

[BMR4620002/001C](#) [BMR4562204/001](#) [PKU 4513 PI](#) [BMR4572105/001](#) [PKJ 4518 PIT](#) [PMP 5818UW SR](#) [PKL 4313 PIT](#) [BMR4530108/014](#)

[PKM4613NHPIHSSP](#) [PKM4204BPILPLC](#) [BMR4560104/001](#) [PKB4619PIPNB](#) [PKM 4110D PINB](#) [PKU4116CSI](#) [BMR4642002/104B](#)

[BMR4642088/001](#) [BMR4540102/004](#) [PKM 4113D PINB](#) [PMJ 4718TSR](#) [PKU 4515 PI](#) [PKJ 4316 PI](#) [BMR4642008/001B](#) [PKF4918BSI](#)

[PKB 4713 PINB](#) [PMJ4718TP](#) [PMJ8118LSR](#) [PKU 4418G PI](#) [BMR4573100/002](#) [BMR4540002/004](#)