

NOTE:

1. MATERIALS: HOUSING - LIQUID CRYSTAL POLYMER (LCP) GLASS-FILLED, UL 94V-0
2. FINISH: SELECTIVE GOLD (Au) 0.76 MICROMETERS MINIMUM IN CONTACT AREA, SELECTIVE MATTE TIN (Sn) ON PCB TAILS, NICKEL (Ni) OVERALL.
3. REFER TO MOLEX PRODUCT SPECIFICATION PS-75221-999 FOR PERFORMANCE SPECIFICATIONS.
4. POSITION OF TAILS TO BE INSPECTED USING TAIL TEMPLATE P/N 74047-0082.
5. PARTS TO BE PACKAGED PER PK-70873-564. QUANTITY PER TRAY POCKET: 12 TOTAL QUANTITY PER TRAY: 72
6. MARK LABEL WITH PART NUMBER AND DATE CODE.
7. ASSEMBLE MODULES TO STIFFENER PER DRAWING E-75226-003.
8. LABEL MAY BE REPLACED BY LASER MARKINGS ON THE STIFFENER.
9. THIS PART CONFORMS TO CLASS "B" REQUIREMENTS OF MOLEX COSMETIC SPECIFICATION PS-45499-002.
10. MOUNTING SCREWS WILL BE BAGGED WITH EACH CONNECTOR.

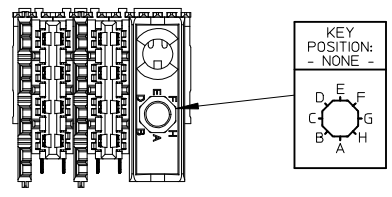

LEAD-FREE PLATING

ITEM	PART NUMBER	DESCRIPTION	QTY
1	75226-0023	STIFFENER	1
2	75227-5014	ESD GROUND MODULE. KEY="NONE"	1
3	73726-0000	GROUND MODULE MNTG SCREW	1
4	75292-4060	POWER MODULE - GBX 4 PAIR, LF	2
5	75228-1004	END CAP WITH PEGS	2

CUSTOMER: GAINSPEED

INITIAL RELEASE EC NO: UCP2014-1858 DRWNS:SVANG01 2014/01/06 CHKD:MWOLFE 2014/01/06 APPR:SMILLER 2014/01/16 REY:	QUALITY SYMBOLS	GENERAL TOLERANCES (UNLESS SPECIFIED)	DIMENSION STYLE <b>MM ONLY</b>	SCALE <b>2:1</b>	DESIGN UNITS <b>METRIC</b>	THIRD ANGLE PROJECTION
	▽=0	mm INCH	DRAWN BY DATE SVANG01 2014/01/06	TITLE	<b>GBX 4 PAIR CUSTOM DAUGHTERCARD, LF ASSEMBLY DRAWING</b>  <b>molex</b>  DOCUMENT NO. <b>E-75220-0337</b> SHEET NO. <b>1 OF 1</b>	
	▽=0	4 PLACES ± --- ± ---	CHECKED BY DATE MWOLFE 2014/01/06			
	▽=0	3 PLACES ± --- ± ---	APPROVED BY DATE SMILLER 2014/01/16			
	▽=0	2 PLACES ± 0.05 ± ---	MATERIAL NO. <b>75220-0337</b>			
▽=0	1 PLACE ± 0.13 ± ---	ANGULAR ±1/2°				
		0 PLACE ± ±	DRAFT WHERE APPLICABLE MUST REMAIN WITHIN DIMENSIONS	SIZE <b>C</b>	THIS DRAWING CONTAINS INFORMATION THAT IS PROPRIETARY TO MOLEX. INCORPORATED AND SHOULD NOT BE USED WITHOUT WRITTEN PERMISSION	

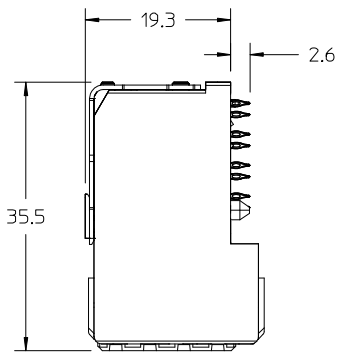
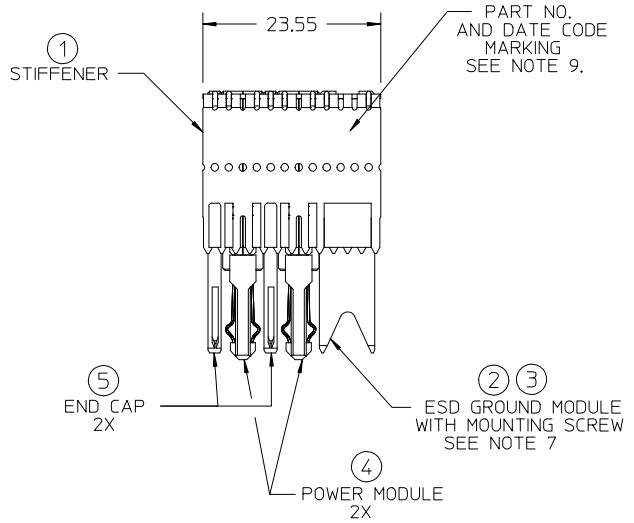

- NOTES: (UNLESS OTHERWISE SPECIFIED)
1. MATERIALS: HOUSING - LIQUID CRYSTAL POLYMER (LCP) GLASS-FILLED, UL 94V-0
  2. FINISH: SELECTIVE GOLD (Au) 0.76 MICROMETERS MINIMUM IN CONTACT AREA, SELECTIVE MATTE TIN (Sn) ON PCB TAILS, NICKEL (Ni) OVERALL.
  3. REFER TO MOLEX PRODUCT SPECIFICATION PS-75221-999 FOR PERFORMANCE SPECIFICATIONS.
  4. REFER TO MOLEX DOCUMENT SD-75292-001 FOR ADDITIONAL DETAIL ON THE GBX 4 PAIR POWER MODULE.
  5. REFER TO MOLEX DOCUMENT SD-75227-001 FOR ADDITIONAL DETAIL ON THE GBX 4 PAIR GROUND MODULE.
  6. REFER TO MOLEX DOCUMENT SD-75228-001 FOR ADDITIONAL DETAIL ON THE GBX 4 PAIR END CAP.
  7. PARTS ARE TO BE PACKAGED IN TRAYS PER PK-70873-564. MOUNTING SCREWS WILL BE BAGGED WITH EACH CONNECTOR.
  8. THIS PART CONFORMS TO CLASS "B" REQUIREMENTS OF MOLEX COSMETIC SPECIFICATION PS-45499-002.
  9. MARK LABEL WITH PART NUMBER AND DATE CODE. LABEL MAY BE REPLACED BY LASER MARKINGS ON THE STIFFENER.

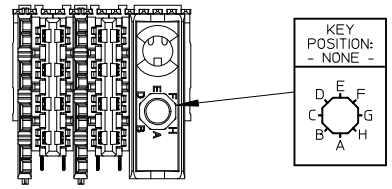

ITEM	PART NUMBER	DESCRIPTION	QTY
1	75226-0023	STIFFENER	1
2	75227-5014	ESD GROUND MODULE, KEY="NONE"	1
3	73726-0000	GROUND MODULE MNTG SCREW	1
4	75292-4060	POWER MODULE - GBX 4 PAIR, LF	2
5	75228-1004	END CAP WITH PEGS	2

LEAD-FREE PLATING

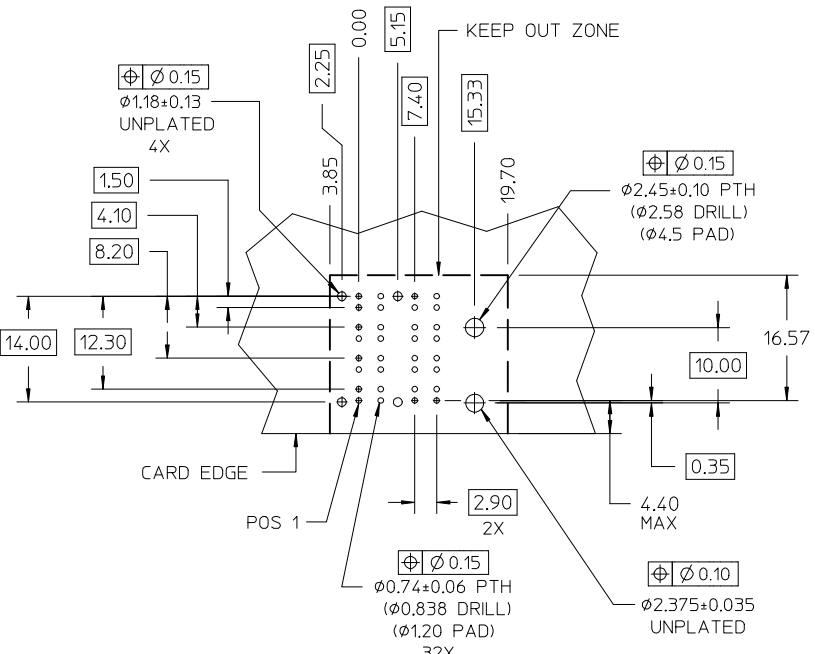

DAUGHTERCARD HOLE PATTERN (CONNECTOR SIDE)

CUSTOMER: GAINSPEED

INITIAL RELEASE EC NO: UCP2014-1858 DRWNS:VANG01 2014/01/06 CHKD:MWOLFE 2014/01/06 APPR:SMILLER 2014/01/16	QUALITY SYMBOLS 	GENERAL TOLERANCES (UNLESS SPECIFIED)		DIMENSION STYLE MM ONLY		SCALE 2:1	DESIGN UNITS METRIC	THIRD ANGLE PROJECTION	
				DRAWN BY DATE SVANG01 2014/01/06		TITLE GBX 4 PAIR CUSTOM DAUGHTERCARD, LF SALES DRAWING			
				CHECKED BY DATE MWOLFE 2014/01/06		DOCUMENT NO. RSD-75220-0337			
				APPROVED BY DATE SMILLER 2014/01/16		SHEET NO. 1 OF 1			
		ANGULAR ±1/2°		MATERIAL NO. 75220-0337					
		DRAFT WHERE APPLICABLE MUST REMAIN WITHIN DIMENSIONS		SIZE C		THIS DRAWING CONTAINS INFORMATION THAT IS PROPRIETARY TO MOLEX. INCORPORATED AND SHOULD NOT BE USED WITHOUT WRITTEN PERMISSION			

## X-ON Electronics

Largest Supplier of Electrical and Electronic Components

*Click to view similar products for [molex](#) manufacturer:*

Other Similar products are found below :

[60506-C-50](#) [73108](#) [72903](#) [1062837003](#) [0533241060](#) [68301-1017](#) [71506-C](#) [880504](#) [387790039](#) [53254-0710](#) [85071-0017](#) [387204903](#)  
[783472003](#) [514412093](#) [0436500518](#) [0194180027](#) [0192210405](#) [0191640082](#) [0982660127](#) [0152670317](#) [0192210414](#) [0982670277](#)  
[0026482195](#) [0191310031](#) [503308-4410](#) [0190070015](#) [02-09-6102](#) [0008650814](#) [791099208](#) [0039000218](#) [89762-1403](#) [89762-1542](#) [89762-](#)  
[1582](#) [0011404526](#) [00136](#) [0022173102](#) [0026615060](#) [CR4006A30M003](#) [0039532085](#) [58098-0628](#) [0003092041](#) [0008520123](#) [0011030025](#)  
[0011184017](#) [0022162060](#) [0022552102](#) [01312](#) [M15730061](#) [61432](#) [6150300002](#)