

## Isolated RS485 Interface

### Functional Diagram

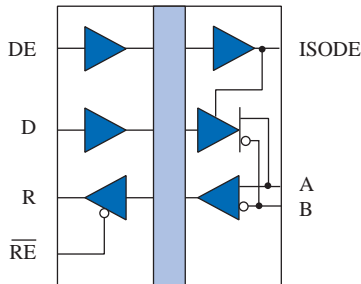

**IL485**

$V_{ID} (A-B)$	DE	$\overline{RE}$	ISODE	R	D	Mode
$\geq 200 \text{ mV}$	L	L	L	H	X	Receive
$\leq -200 \text{ mV}$	L	L	L	L	X	Receive
$-7 < V_{ID} < 12$	X	H	X	Z	X	Receive/Drive
$\geq 1.5 \text{ V}$	H	L	H	H	H	Drive
$\leq -1.5 \text{ V}$	H	L	H	L	L	Drive
Open	L	L	L	H	X	Indeterminate

H = High Level, L = Low Level  
X = Irrelevant, Z = High Impedance

### Features

- 3.3 V Input Supply Compatible
- 2500 V<sub>RMS</sub> Isolation (1 min.)
- 25 ns Maximum Propagation Delay
- 35 Mbps Data Rate
- 1 ns Pulse Skew (typ.)
- Designed for Multi-point Transmission on Long Bus Lines in Noisy Environments
- $\pm 60 \text{ mA}$  Driver Output Capability
- Thermal Shutdown Protection
- Meets or Exceeds ANSI RS-485 and ISO 8482:1987(E)
- $-40^\circ\text{C}$  to  $+85^\circ\text{C}$  Temperature Range
- PROFIBUS International Component Recognition
- 16-Pin SOIC Package
- UL1577 and IEC 61010-2001 Approval

### Applications

- Profibus/RS485 Systems
- Multiple Data Point Transmission

### Description

The IL485 is a galvanically isolated, high-speed differential bus transceiver, designed for bidirectional data communication on balanced transmission lines. The devices use NVE's patented\* IsoLoop spintronic Giant Magnetoresistance (GMR) technology. The IL485 is the first isolated RS-485 interface in a standard 16-pin SOIC package that meets the ANSI Standards EIA/TIA-422-B and RS-485 and is compatible with 3.3V input supplies.

The IL485 has current limiting and thermal shutdown features to protect against output short circuits and bus contention situations that could cause excessive power dissipation.

With 1 ns pulse skew and 16 ns propagation delay, the IL485 is ideal for PROFIBUS applications.

## Absolute Maximum Ratings<sup>(1)</sup>

Parameters	Symbol	Min.	Typ.	Max.	Units	Test Conditions
Storage Temperature	$T_s$	-65		150	°C	
Ambient Operating Temperature	$T_A$	-40		100	°C	
Voltage Range at A or B Bus Pins		-7		12	V	
Supply Voltage <sup>(1)</sup>	$V_{DD1}, V_{DD2}$	-0.5		7	V	
Digital Input Voltage		-0.5		$V_{DD} + 0.5$	V	
Digital Output Voltage		-0.5		$V_{DD} + 1$	V	
Continuous Total Power Dissipation				725 377	mW	25°C 85°C
Maximum Output Current	$I_O$			95	mA	
Lead Solder Temperature				260	°C	10 sec.
ESD			2		kV	HBM

## Recommended Operating Conditions

Parameters	Symbol	Min.	Typ.	Max.	Units	Test Conditions
Supply Voltage	$V_{DD1}$ $V_{DD2}$	3.0 4.5		5.5 5.5	V	
Input Voltage at any Bus Terminal (separately or common mode)	$V_I$ $V_{IC}$			12 -7	V	
High-Level Digital Input Voltage	$V_{IH}$	2.4 3.0		$V_{DD1}$	V	$V_{DD1} = 3.3\text{ V}$ $V_{DD1} = 5.0\text{ V}$
Low-Level Digital Input Voltage	$V_{IL}$	0		0.8	V	
Differential Input Voltage <sup>(2)</sup>	$V_{ID}$			+12/-7	V	
High-Level Output Current (Driver)	$I_{OH}$			60	mA	
High-Level Digital Output Current (Receiver)	$I_{OH}$			8	mA	
Low-Level Output Current (Driver)	$I_{OL}$	-60			mA	
Low-Level Digital Output Current (Receiver)	$I_{OL}$	-8			mA	
Ambient Operating Temperature	$T_A$	-40		85	°C	
Transient Immunity		20			kV/μs	
Digital Input Signal Rise and Fall Times	$t_{IR}, t_{IF}$			DC Stable		

## Insulation Specifications

Parameters	Symbol	Min.	Typ.	Max.	Units	Test Conditions
Creepage Distance		8.08				mm
Barrier Impedance			$>10^{14} \parallel 7$			$\Omega \parallel \text{pF}$
Leakage Current			0.2		μA	240 $V_{RMS}$ , 60 Hz

## Safety and Approvals

### IEC61010-1

TUV Certificate Numbers: **N1502812, N1502812-101**

### Classification: Reinforced Insulation

Model	Package	Pollution Degree	Material Group	Max. Working Voltage
IL485	0.3" SOIC	II	III	300 $V_{RMS}$

### UL 1577

Component Recognition Program File Number: E207481  
Rated 2500  $V_{RMS}$  for 1 minute

### Soldering Profile

Per JEDEC J-STD-020C, MSL=2

**IL485 Pin Connections**

1	V <sub>DD1</sub>	Input Power Supply
2	GND <sub>1</sub>	Input Power Supply Ground Return
3	R	Output Data from Bus
4	$\overline{RE}$	Read Data Enable (if RE is high, R = high impedance)
5	DE	Drive Enable
6	D	Data Input to Bus
7	NC	No Internal Connection
8	GND <sub>1</sub>	Input Power Supply Ground Return
9	GND <sub>2</sub>	Output Power Supply Ground Return
10	ISODE	Isolated DE Output for use in Profibus applications where the state of the isolated drive enable node needs to be monitored
11	NC	No Internal Connection
12	A	Non-inverting Bus Line
13	B	Inverting Bus Line
14	NC	No Internal Connection
15	GND <sub>2</sub>	Output Power Supply Ground Return.
16	V <sub>DD2</sub>	Output Power Supply

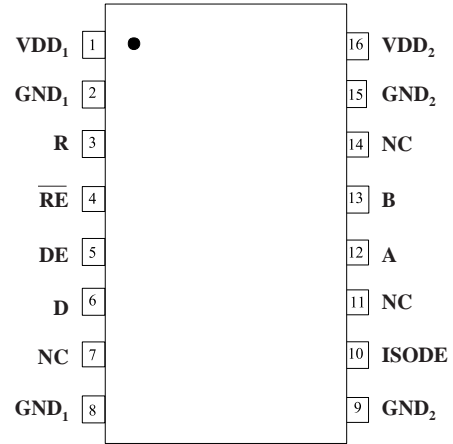

## Driver Section

Electrical Specifications are  $T_{min}$  to  $T_{max}$  and  $V_{DD} = 4.5\text{ V}$  to  $5.5\text{ V}$ , unless otherwise stated.

Parameters	Symbol	Min.	Typ. <sup>(5)</sup>	Max.	Units	Test Conditions
Input Clamp Voltage	$V_{IK}$			-1.5	V	$I_L = -18\text{ mA}$
Output voltage	$V_O$	0		6	V	$I_O = 0$
Differential Output Voltage <sup>(2)</sup>	$ V_{OD1} $	1.5		6	V	$I_O = 0$
Differential Output Voltage <sup>(2)</sup>	$ V_{OD2} $	1.5	2.5	5	V	$R_L = 54\ \Omega$ , $V_{DD} = 5\text{ V}$
Differential Output Voltage <sup>(2)(6)</sup>	$V_{OD3}$	1.5		5	V	$R_L = 54\ \Omega$ , $V_{DD} = 4.5\text{ V}$
Change in Magnitude of Differential Output Voltage <sup>(7)</sup>	$\Delta V_{OD} $			$\pm 0.2$	V	$R_L = 54\ \Omega$ or $100\ \Omega$
Common Mode Output Voltage	$V_{OC}$			3 -1	V	$R_L = 54\ \Omega$ or $100\ \Omega$
Change in Magnitude of Common Mode Output Voltage <sup>(7)</sup>	$\Delta V_{OC} $			$\pm 0.2$	V	$R_L = 54\ \Omega$ or $100\ \Omega$
Output Current <sup>(4)</sup> <i>Output Disabled</i>	$I_O$			1 -0.8	mA	$V_O = 12\text{ V}$ $V_O = -7\text{ V}$
High Level Input Current	$I_{IH}$			10	$\mu\text{A}$	$V_I = 3.5\text{ V}$
Low Level Input Current	$I_{IL}$			-10	$\mu\text{A}$	$V_I = 0.4\text{ V}$
Short-circuit Output Current	$I_{OS}$			250 -150 -250	mA	$V_O = -6\text{ V}$ $V_O = 0\text{ V}$ $V_O = 8\text{ V}$
Supply Current $V_{DD1} = +5\text{ V}$ $V_{DD1} = +3.3\text{ V}$	$I_{DD1}$ $I_{DD1}$		4 3	6 4	mA	No Load (Outputs Enabled)

### Switching Specifications

Parameters	Symbol	Min.	Typ. <sup>(5)</sup>	Max.	Units	Test Conditions
Maximum Data Rate		35			Mbps	$R_L = 54\ \Omega$ , $C_L = 50\text{ pF}$
Differential Output Prop Delay	$t_D(\text{OD})$		16	25	ns	$R_L = 54\ \Omega$ , $C_L = 50\text{ pF}$
Pulse Skew <sup>(10)</sup>	$t_S(\text{P})$		1	6	ns	$R_L = 54\ \Omega$ , $C_L = 50\text{ pF}$
Differential Output Rise & Fall Time	$t_T(\text{OD})$		8	10	ns	$R_L = 54\ \Omega$ , $C_L = 50\text{ pF}$
Output Enable Time To High Level	$t_{PZH}$		31	65	ns	$R_L = 54\ \Omega$ , $C_L = 50\text{ pF}$
Output Enable Time To Low Level	$t_{PZL}$		22	35	ns	$R_L = 54\ \Omega$ , $C_L = 50\text{ pF}$
Output Disable Time From High Level	$t_{PHZ}$		28	50	ns	$R_L = 54\ \Omega$ , $C_L = 50\text{ pF}$
Output Disable Time From Low Level	$t_{PLZ}$		16	32	ns	$R_L = 54\ \Omega$ , $C_L = 50\text{ pF}$
Skew Limit <sup>(3)</sup>	$t_{SK}(\text{LIM})$		2	12	ns	$R_L = 54\ \Omega$ , $C_L = 50\text{ pF}$

### Notes (apply to both driver and receiver sections):

- All voltage values are with respect to network ground except differential I/O bus voltages.
- Differential input/output voltage is measured at the noninverting terminal A with respect to the inverting terminal B.
- Skew limit is the maximum propagation delay difference between any two devices at  $25^\circ\text{C}$ .
- The power-off measurement in ANSI Standard EIA/TIA-422-B applies to disabled outputs only and is not applied to combined inputs and outputs.
- All typical values are at  $V_{DD1}, V_{DD2} = 5\text{ V}$  or  $V_{DD1} = 3.3\text{ V}$  and  $T_A = 25^\circ\text{C}$ .
- The minimum  $V_{OD2}$  with a  $100\ \Omega$  load is either  $\frac{1}{2} V_{OD1}$  or  $2\text{ V}$ , whichever is greater.
- $\Delta|V_{OD}|$  and  $\Delta|V_{OC}|$  are the changes in magnitude of  $V_{OD}$  and  $V_{OC}$ , respectively, that occur when the input is changed from one logic state to the other.
- This applies for both power on and power off, refer to ANSI standard RS-485 for exact condition. The EIA/TIA-422-B limit does not apply for a combined driver and receiver terminal.
- Includes 8 ns read enable time. Maximum propagation delay is 25 ns after read assertion.
- Pulse skew is defined as  $|t_{PLH} - t_{PHL}|$  of each channel.
- The relevant test and measurement methods are given in the Electromagnetic Compatibility section on p. 6.
- External magnetic field immunity is improved by this factor if the field direction is “end-to-end” rather than to “pin-to-pin” (see diagram on p. 6).

## Receiver Section

Electrical Specifications are  $T_{min}$  to  $T_{max}$  and  $V_{DD} = 4.5\text{ V}$  to  $5.5\text{ V}$ , unless otherwise stated.

Parameters	Symbol	Min.	Typ. <sup>(5)</sup>	Max.	Units	Test Conditions
Positive-going Input Threshold Voltage	$V_{IT+}$			0.2	V	$V_o = 2.7\text{ V}$ , $I_o = -0.4\text{ mA}$
Negative-going Input Threshold Voltage	$V_{IT-}$	-0.2			V	$V_o = 0.5\text{ V}$ , $I_o = 8\text{ mA}$
Hysteresis Voltage ( $V_{IT+} - V_{IT-}$ )	$V_{HYS}$		60		mV	
High Level Digital Output Voltage	$V_{OH}$	$V_{DD} - 0.2$			V	$V_{ID} = 200\text{ mV}$ $I_{OH} = -20\text{ }\mu\text{A}$
Low Level Digital Output Voltage	$V_{OL}$			0.2	V	$V_{ID} = -200\text{ mV}$ $I_{OH} = 20\text{ }\mu\text{A}$
High-impedance-state output current	$I_{OZ}$			$\pm 20$	$\mu\text{A}$	$V_o = 0.4$ to $(V_{DD2} - 0.5)\text{ V}$
Line Input Current <sup>(8)</sup>	$I_i$			1 -0.8	mA	$V_i = 12\text{ V}$ $V_i = -7\text{ V}$ Other Input <sup>(11)</sup> = 0 V
Input Resistance	$r_i$	12	20		k $\Omega$	
Supply Current	$I_{DD2}$		27	34	mA	No load Outputs Enabled

### Switching Characteristics at 5 V

Parameters	Symbol	Min.	Typ. <sup>(5)</sup>	Max.	Units	Test Conditions
Maximum Data Rate		35			Mbps	$R_L = 54\text{ }\Omega$ , $C_L = 50\text{ pF}$
Propagation Delay <sup>(2, 9)</sup>	$t_{PD}$		24	32	ns	$V_o = -1.5\text{ V}$ to $1.5\text{ V}$ , $C_L = 15\text{ pF}$
Pulse Skew <sup>(2, 10)</sup>	$t_{sk}(P)$		1	6	ns	$V_o = -1.5\text{ V}$ to $1.5\text{ V}$ , $C_L = 15\text{ pF}$
Skew Limit <sup>(3)</sup>	$t_{sk}(LIM)$		2	8	ns	$R_L = 54\text{ }\Omega$ , $C_L = 50\text{ pF}$
Output Enable Time To High Level	$t_{PZH}$		17	24	ns	$C_L = 15\text{ pF}$
Output Enable Time To Low Level	$t_{PZL}$		30	45	ns	$C_L = 15\text{ pF}$
Output Disable Time From High Level	$t_{PHZ}$		30	45	ns	$C_L = 15\text{ pF}$
Output Disable Time From Low Level	$t_{PLZ}$		18	27	ns	$C_L = 15\text{ pF}$

### Switching Characteristics at 3.3 V

Parameters	Symbol	Min.	Typ. <sup>(5)</sup>	Max.	Units	Test Conditions
Maximum Data Rate		35			Mbps	$R_L = 54\text{ }\Omega$ , $C_L = 50\text{ pF}$
Propagation Delay <sup>(2, 9)</sup>	$t_{PD}$		27	32	ns	$V_o = -1.5\text{ V}$ to $1.5\text{ V}$ , $C_L = 15\text{ pF}$
Pulse Skew <sup>(2, 10)</sup>	$t_{sk}(P)$		2	6	ns	$V_o = -1.5\text{ V}$ to $1.5\text{ V}$ , $C_L = 15\text{ pF}$
Skew Limit <sup>(3)</sup>	$t_{sk}(LIM)$		4	8	ns	$R_L = 54\text{ }\Omega$ , $C_L = 50\text{ pF}$
Output Enable Time to High Level	$t_{PZH}$		20	24	ns	$C_L = 15\text{ pF}$
Output Enable Time to Low Level	$t_{PZL}$		33	45	ns	$C_L = 15\text{ pF}$
Output Disable Time from High Level	$t_{PHZ}$		33	45	ns	$C_L = 15\text{ pF}$
Output Disable Time from Low Level	$t_{PLZ}$		20	27	ns	$C_L = 15\text{ pF}$

## Magnetic Field Immunity<sup>(11)</sup>

### Magnetic Field Immunity at 5 V

Power Frequency Magnetic Immunity	$H_{PF}$	2800	3500		A/m	50Hz/60Hz
Pulse Magnetic Field Immunity	$H_{PM}$	4000	4500		A/m	$t_p = 8\mu\text{s}$
Damped Oscillatory Magnetic Field	$H_{OSC}$	4000	4500		A/m	0.1Hz – 1MHz
Cross-axis Immunity Multiplier <sup>(12)</sup>	$K_X$		2.5			

### Magnetic Field Immunity at 3.3 V

Power Frequency Magnetic Immunity	$H_{PF}$	1000	1500		A/m	50Hz/60Hz
Pulse Magnetic Field Immunity	$H_{PM}$	1800	2000		A/m	$t_p = 8\mu\text{s}$
Damped Oscillatory Magnetic Field	$H_{OSC}$	1800	2000		A/m	0.1Hz – 1MHz
Cross-axis Immunity Multiplier <sup>(12)</sup>	$K_X$		2.5			

**Application Information**

**Electrostatic Discharge Sensitivity**

This product has been tested for electrostatic sensitivity to the limits stated in the specifications. However, NVE recommends that all integrated circuits be handled with appropriate care to avoid damage. Damage caused by inappropriate handling or storage could range from performance degradation to complete failure.

**Electromagnetic Compatibility**

The IL485 is fully compliant with generic EMC standards EN50081, EN50082-1 and the umbrella line-voltage standard for Information Technology Equipment (ITE) EN61000. The IsoLoop Isolator’s Wheatstone bridge configuration and differential magnetic field signaling ensure excellent EMC performance against all relevant standards. NVE conducted compliance tests in the categories below:

- EN50081-1  
Residential, Commercial & Light Industrial  
Methods EN55022, EN55014
- EN50082-2: Industrial Environment  
Methods EN61000-4-2 (ESD), EN61000-4-3 (Electromagnetic Field Immunity), EN61000-4-4 (Electrical Transient Immunity), EN61000-4-6 (RFI Immunity), EN61000-4-8 (Power Frequency Magnetic Field Immunity), EN61000-4-9 (Pulsed Magnetic Field), EN61000-4-10 (Damped Oscillatory Magnetic Field)
- ENV50204  
Radiated Field from Digital Telephones (Immunity Test)

Immunity to external magnetic fields is even higher if the field direction is “end-to-end” rather than to “pin-to-pin” as shown in the diagram below:

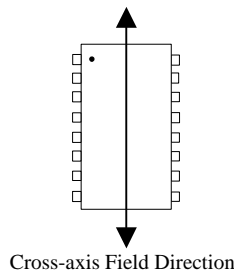

**Dynamic Power Consumption**

IsoLoop Isolators achieve their low power consumption from the way they transmit data across the isolation barrier. By detecting the edge transitions of the input logic signal and converting these to narrow current pulses, a magnetic field is created around the GMR Wheatstone bridge. Depending on the direction of the magnetic field, the bridge causes the output comparator to switch following the input logic signal. Since the current pulses are narrow, about 2.5 ns, the power consumption is independent of mark-to-space ratio and solely dependent on frequency. This has obvious advantages over optocouplers, which have power consumption heavily dependent on frequency and time.

The approximate power supply current per channel is:

$$I_{IN} = 40 \times \frac{f}{f_{MAX}} \times \frac{1}{4} \text{ mA}$$

Where f = operating frequency

$$f_{MAX} = 50 \text{ MHz}$$

**Power Supply Decoupling**

Both V<sub>DD1</sub> and V<sub>DD2</sub> must be bypassed with 47 nF ceramic capacitors. These should be placed as close as possible to V<sub>DD</sub> pins for proper operation. Additionally, V<sub>DD2</sub> should be bypassed with a 10 μF tantalum capacitor.

**0.3" 16-pin SOIC Package**

Dimensions in inches (mm)

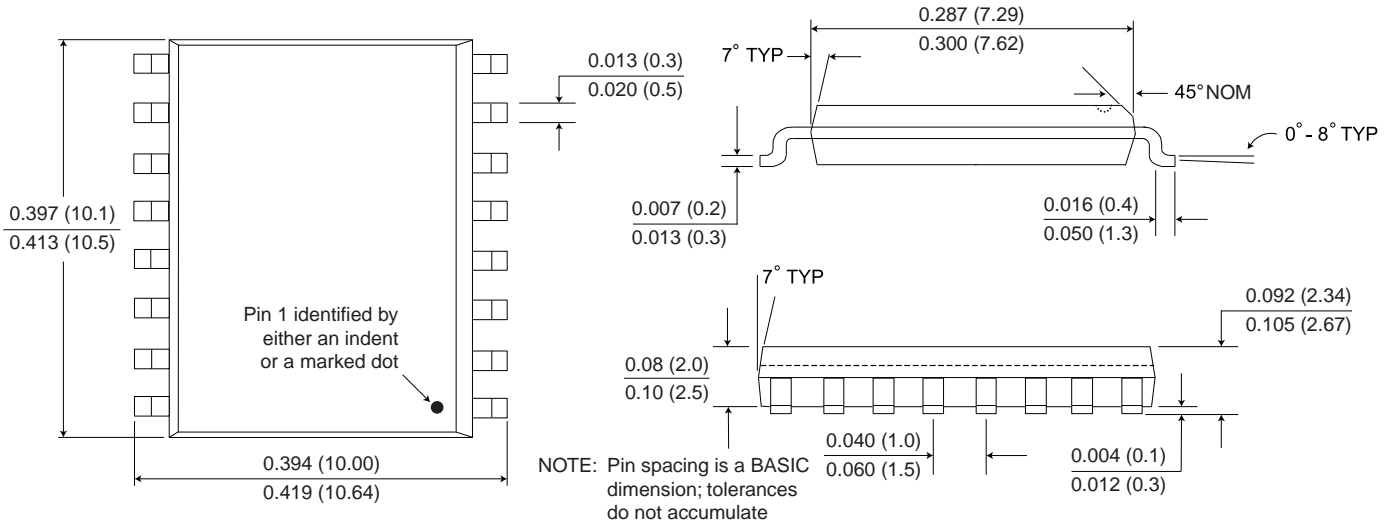

**Ordering Information and Valid Part Numbers**

**IL 485 E TR13**

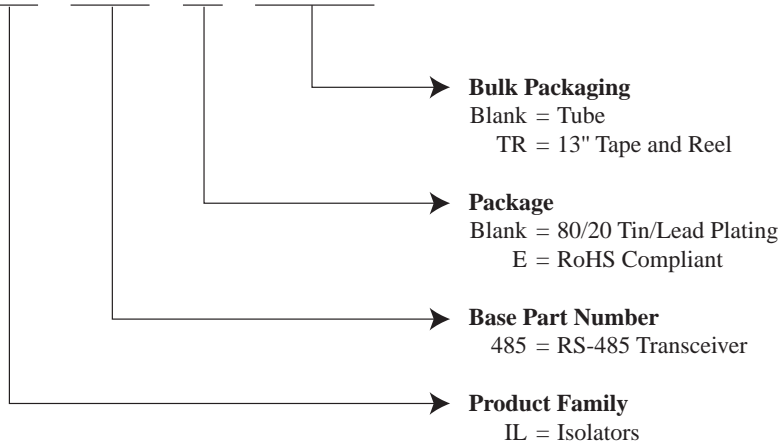

**Valid Part Numbers**

IL485  
IL485E

All IL485 part types are available on tape and reel.



**ISB-DS-001-IL485-Q**  
**March 2008**

**Changes**

- Added magnetic field immunity and electromagnetic compatibility specifications.
- Added note on package drawing that pin-spacing tolerances are non-accumulating.

**ISB-DS-001-IL485-P**

**Changes**

- Changed ordering information to reflect that devices are now fully RoHS compliant with no exemptions.

**ISB-DS-001-IL485-O**

**Changes**

- Reorganized supply current specifications; misc. minor changes

**ISB-DS-001-IL485-N**

**Changes**

- Eliminated soldering profile chart

**ISB-DS-001-IL485-M**

**Changes**

- Updated open input state in truth table

**ISB-DS-001-IL485-L**

**Changes**

- Updated package drawing; misc. changes

**ISB-DS-001-IL485-K**

**Changes**

- Update UL and IEC approvals

**ISB-DS-001-IL485-J**

**Changes**

- Revision letter added.
- Ordering Information Removed.
- IEC 61010-1 “Reinforced Insulation” added.
- Notes added.
- PagIR Soldering Profile added
- Ordering Information added.



## About NVE

An ISO 9001 Certified Company

NVE Corporation manufactures innovative products based on unique spintronic Giant Magnetoresistive (GMR) technology. Products include Magnetic Field Sensors, Magnetic Field Gradient Sensors (Gradiometers), Digital Magnetic Field Sensors, Digital Signal Isolators, and Isolated Bus Transceivers.

NVE pioneered spintronics and in 1994 introduced the world's first products using GMR material, a line of ultra-precise magnetic sensors for position, magnetic media, gear speed and current sensing.

NVE Corporation  
11409 Valley View Road  
Eden Prairie, MN 55344-3617 USA  
Telephone: (952) 829-9217  
Fax: (952) 829-9189  
Internet: [www.nve.com](http://www.nve.com)  
e-mail: [isoinfo@nve.com](mailto:isoinfo@nve.com)

*The information provided by NVE Corporation is believed to be accurate. However, no responsibility is assumed by NVE Corporation for its use, nor for any infringement of patents, nor rights or licenses granted to third parties, which may result from its use. No license is granted by implication, or otherwise, under any patent or patent rights of NVE Corporation. NVE Corporation does not authorize, nor warrant, any NVE Corporation product for use in life support devices or systems or other critical applications, without the express written approval of the President of NVE Corporation.*

***Specifications shown are subject to change without notice.***

ISB-DS-001-IL485-Q

March 2008

## X-ON Electronics

Largest Supplier of Electrical and Electronic Components

*Click to view similar products for [Digital Isolators](#) category:*

*Click to view products by [NVE](#) manufacturer:*

Other Similar products are found below :

[ADUM1281WARZ](#) [ADUM3160WBRWZ](#) [ADUM1280WARZ](#) [ADUM1442ARSZ-RL7](#) [ADUM5230WARWZ](#) [ADUM1285WARZ](#)  
[ADUM1285WCRZ](#) [ADUM1286WCRZ](#) [ADUM1445ARSZ-RL7](#) [ADUM1285WBRZ](#) [ADUM1280WCRZ](#) [ADN4652BRWZ-RL7](#)  
[MAX14850ASE+T](#) [MAX14932AAWE](#) [ISO1I813T](#) [ADUM2251WARWZ](#) [MAX14850AEE+T](#) [ADUM3471WARSZ](#) [ADUM3472WARSZ](#)  
[ADUM2250WARWZ](#) [SI8380P-IUR](#) [MAX12931FASA+](#) [ADUM3211TRZ-EP-RL7](#) [ADP1032ACPZ-2-R7](#) [ADUM7223ACCZ-R7](#)  
[ADP1032ACPZ-4-R7](#) [ADP1032ACPZ-1-R7](#) [ADP1032ACPZ-5-R7](#) [ADP1032ACPZ-3-R7](#) [ADUM3301WARWZ](#) [SI8388P-IUR](#)  
[ADUM141E0WBRQZ-RL7](#) [ADUM141E0WBRQZ](#) [ADN4651BRWZ-RL7](#) [ADUM1246ARZ-RL7](#) [140U30](#) [MCP2022A-330E/ST](#)  
[MCP2022A-500E/ST](#) [MCP2021-500E/P](#) [MCW1001A-I/SS](#) [IL260-1E](#) [IL260VE](#) [IL261-1E](#) [IL261VE](#) [IL262E](#) [IL3122E](#) [IL3185-3E](#) [IL3485-3E](#) [IL3685E](#) [IL514E](#)