



**TELEDYNE
RELAYS**
 A Teledyne Technologies Company

NEW!

MAGNETIC-LATCHING DPDT HALF-SIZE CRYSTAL CAN MILITARY RELAY

SERIES
 J255/255
 256
 257
 258

SERIES DESIGNATION	RELAY TYPE
J255	Magnetic-latching DPDT half-size crystal can relay qualified to MIL-PRF-39016/45
255, 256, 257, 258	Commercial magnetic-latching DPDT half-size crystal can relay

ENVIRONMENTAL AND PHYSICAL SPECIFICATIONS	
Temperature (Ambient)	-65°C to +125°C
Vibration (Sinusoidal)	30G, 10 to 2500 Hz (See Note 1)
Shock (Specified Pulse)	100 G, 6ms half sine (See Note 2)
Enclosure	Hermetically sealed
Weight	0.46 oz. (13g) max.

FEATURES/BENEFITS

- Low level to 2 amps
- Wide range of switching capabilities
- Smallest relay package capable of switching 2 amps
- Modernized assembly process
- Qualified to MIL-PRF39016/45 (J255 only)
- Lead-free (gold-plated wire lead only)

DESCRIPTION

The Series J255/255 is an industry-standard, half-size, latching crystal can relay. It has a wide range of switching capabilities ranging from low level to 2 amps. The Series J255/255 latching relay configuration is double-pole double-throw (DPDT), so the relay offers excellent switching density and versatility.

Teledyne Relays' Series J255/255 offers:

- All welded construction
- Wire leads, gold-plated or solder-coated
- Matched seal for superior hermeticity
- Gold-plated contact assembly
- Modernized assembly process
- Advanced cleaning techniques

The 256, 257 and 258 variations of the 255 feature different schematics.

SCHEMATIC DIAGRAM (TERMINAL VIEW)

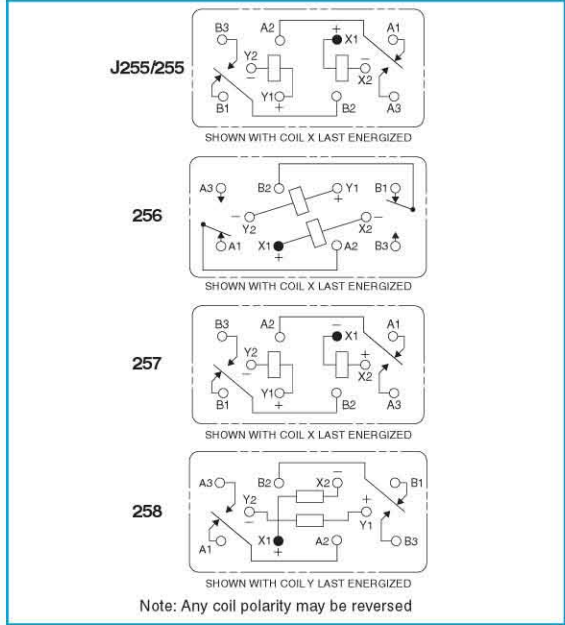

SERIES J255 and 255
GENERAL ELECTRICAL SPECIFICATIONS (-65°C to +125°C unless otherwise noted)

Contact Arrangement	2 Form C (DPDT)		
Contact Load Ratings (Case Grounded)	Low Level Life: 10–50 μ A @10–50 mV, 1,000,000 cycles Resistive: 2A @ 28Vdc, 100,000 cycles .15A @ 115Vac, 60 and 400Hz, 100,000 cycles Lamp: 0.16A @ 28Vdc, 100,000 cycles Intermediate Current: 0.1A 28 Vdc, 50,000 cycles Inductive: 0.75A @ 28Vdc 200 mH, 100,000 cycles		
Contact Resistance	Low Level: 0.050 Ω maximum before life 0.150 Ω maximum after life High Level: 0.050 Ω maximum before life 0.100 Ω maximum after life		
Contact Bounce	3.0 ms maximum		
Contact Overload Rating	4 A/28Vdc Resistive (100 cycles min.)		
Operating Time	4 ms maximum over temperature range with rated coil voltage		
Insulation Resistance	1,000 M Ω minimum, except the resistance between coil and case at high temperature shall be 500 M Ω or greater		
Dielectric Strength	Between case, frame, or enclosure and all contacts in the latched and non-latched positions	Sea Level 1,000 Vrms (60 Hz)	Altitude 350 Vrms (60 Hz)
	Between case, frame or enclosure and coils	500 Vrms (60 Hz)	350 Vrms (60 Hz)
	Between all contacts and coils	1,000 Vrms (60 Hz)	350 Vrms (60 Hz)
	Between open contacts in the latched and non-latched positions	500 Vrms (60 Hz)	350 Vrms (60 Hz)
	Between coils	500 Vrms (60 Hz)	350 Vrms (60 Hz)
	Between contact poles	1,000 Vrms (60 Hz)	350 Vrms (60 Hz)
Minimum Operate Pulse	9 ms @ rated voltage		

DETAILED ELECTRICAL SPECIFICATIONS (-65°C to +125°C unless otherwise noted)

BASE PART NUMBERS (See Note 12 for full P/N example)		J255-5 255-5	J255-6 255-6	J255-12 255-12	J255-26 255-26
Coil Voltage (Vdc)	Nom.	5.0	6.0	12.0	26.5
	Max.	6.7	8.0	16.0	32.0
Coil Resistance (Ohms \pm10%, 25°C)		45	63	254	1000
Set/Reset Voltage (Vdc)	Min.	1.0	1.3	2.6	5.2
	Max.	3.8	4.5	9.0	18.0
	Min. @25°C Max. @25°C	1.6 2.7	2.0 3.25	4.0 6.5	8.0 13.0

TERMINAL CONNECTIONS

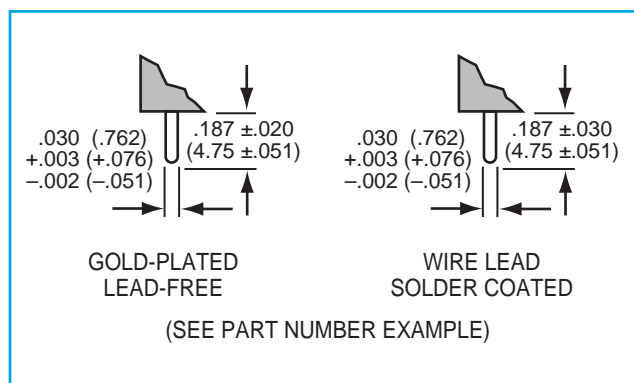

NOTES:

- Vibration (sinusoidal): MIL-STD-202, method 204, test condition D (except frequency shall be 10 to 2,500 Hz). Contact chatter shall not exceed 10 μ s maximum for closed contacts, and 1 μ s maximum closure for open contacts. Vibration (random): MIL-STD-202, method 214, test condition IG. Contact chatter shall not exceed 10 μ s maximum for closed contacts, and 1 μ s maximum closure for open contacts (applicable to qualification and group C testing only).
- Shock (half-sine pulse): MIL-STD-202, method 213, test condition C (100 g's). Contact chatter shall not exceed 10 μ s maximum for closed contacts, and 1 μ s maximum closure for open contacts.
- Dimensions are in inches. Metric equivalents in parentheses for reference only.
- Unless otherwise specified, tolerance is ± 0.010 (0.25mm).
- Indicated terminal is marked with a contrasting bead.
- Unless otherwise specified, relays will be supplied with either gold-plated or solder-coated leads. The slash and characters appearing after the slash are not marked on the relay.
- When latching relays are installed in equipment, the latch and reset coils should not be pulsed simultaneously.
- Each relay possesses high-level and low-level capabilities. However, relays previously tested or used above 10 mA resistive at 6 Vdc maximum or peak ac open circuits not recommended for subsequent use in low-level applications.
- Relays may be subjected to 260°C (1 minute) peak solder reflow temperature.
- For hi-rel applications, contact factory at (800) 284-7007.
- The suffix letter L and M to designate the applicable failure rate level shall be added to the applicable listed dash number. Failure rate level (percent per 10,000 cycles): L = 3.0; M = 1.0.

**SERIES J255 and 255
OUTLINE DIMENSIONS**

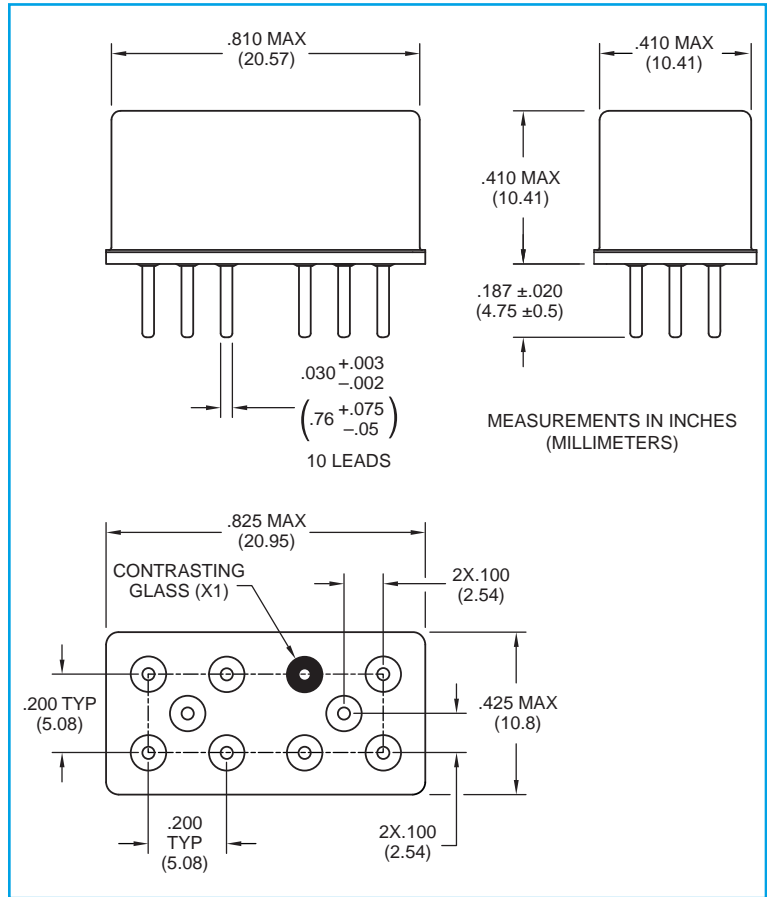

**12. Teledyne Part Numbering System for Standard Relays
EXAMPLE:**

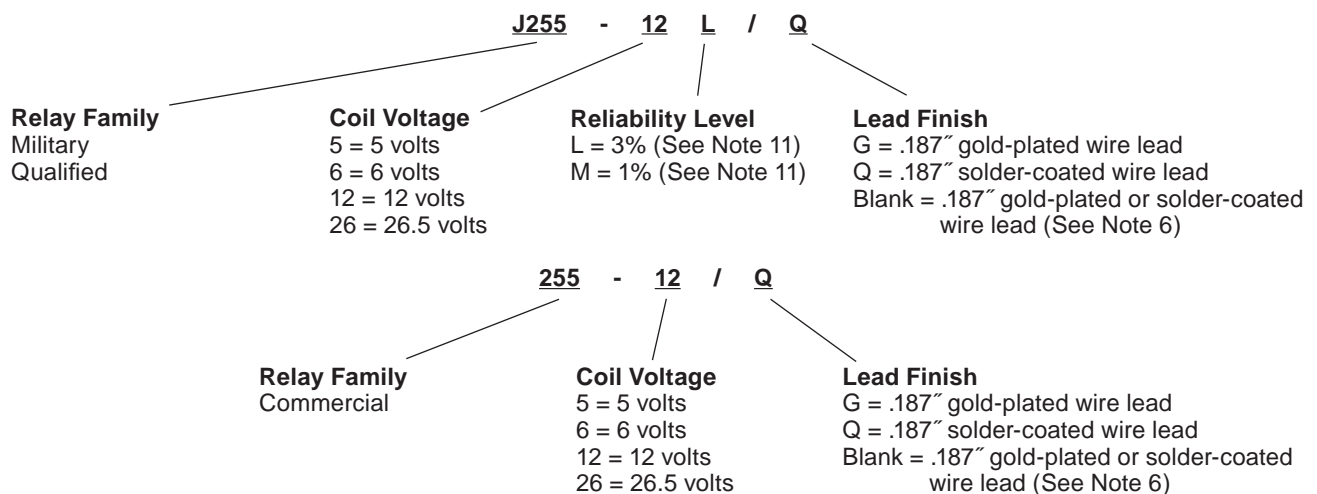

X-ON Electronics

Largest Supplier of Electrical and Electronic Components

Click to view similar products for [teledyne manufacturer](#):

Other Similar products are found below :

[CR-33S6E-TMS](#) [CR-38S33C-T](#) [611-13](#) [M28776/3-036L](#) [712DM2-12](#) [732DM-12](#) [EUM099-M265](#) [EUM139-M265](#) [FB512FSZ](#)
[MOSD5050R200L](#) [MOSFD5050R200L](#) [MOSFD5050R50H](#) [MOSFD5050R50L](#) [PK007-003](#) [PK007-019](#) [PK007-024](#) [PK007-026](#) [PK116-2](#)
[PK116-3](#) [PK1-5MM-102](#) [PK1-5MM-105](#) [PK1-5MM-120](#) [PK400-1](#) [PK702](#) [PKIT3-5MM-101](#) [PK-ZS-003](#) [PK-ZS-006](#) [PK-ZS-008](#) [PK-ZS-](#)
[012](#) [PK-ZS-015](#) [PK-ZS-021](#) [PK-ZS-022](#) [PK-ZS-024](#) [GEN500-16B-60](#) [DRDT600240A10](#) [MS-250](#) [E3PT48A12](#) [E3PT48A50H](#) [EFD113R-](#)
[D70](#) [EFM099R-M79](#) [EFM119-M160](#) [EFM411-M359*](#) [EFM759-M166*](#) [EFMT524-M159](#) [EFMT723-M159](#) [EFR1200480A150](#)
[EFRD1200480R150](#) [EFRTP600240R150](#) [EISC82-TD](#) [MSO-DLS-18](#)