

Series 970 PowerTrip™ Connectors and Accessories Accessories

770-003S Heatshrink Boots



HEATSHRINK BOOTS



Heatshrink boots provide strain relief and environmental protection. Shape-memory polymer returns to as-molded shape when heat is applied. Use with 310-001 unshielded boot adapters or 440-069 **Band-Master™** EMI adapters. Boot lip fits adapter groove for precise fit. Semi-rigid high performance elastomer resists high temperature and withstands exposure to petroleum-based fluids and fuels. Also available with non-halogenated flame-retardant polyolefin for use where limited fire hazard is required.

About User-Installed Adhesive

Heat-shrink boots are not watertight unless equipped with pre-coated or user-installed adhesives. When heat is applied to the boot, the adhesive melts and fixes the boot to the adapter and cable jacket to provide the necessary sealing as well as mechanical strain-relief. For maximum performance Glenair recommends Type U user-installed two-part epoxy adhesive which offers reduced boot installation time and easier installation. Pre-coated boots require additional care to install because the boot must be heated sufficiently to activate the epoxy, at the risk of overheating the overall assembly. A single 50 ml duo syringe can coat many boots. The duo syringe can be re-capped for re-use. Inexpensive mixing nozzles must be discarded after each use.

NOTE: Glenair high-performance two part epoxy meets VG95343 part 15.

See next page for ordering information on user-installed two part epoxy adhesive.



Series 77 "Full Nelson" Shrink Boot Catalog has additional boot styles, technical information, installation instructions and other heatshrink products. Contact Glenair or go to www.glenair.com.

MATERIAL SELECTION GUIDE

- 1 High Performance Elastomer** -75°C to +150°C. Semi-rigid high performance elastomer combines excellent resistance to fuels, oils and solvents with superior performance at extreme temperatures. Material meets the requirements of VG95343 Type 6, BSG 198-5-DE, EN62329-102 and SAE AS5258 Type H. These boots are recommended for demanding applications such as military vehicles and petrochemical exploration.
- 2 Zero Halogen Polyolefin** -30°C to +135°C. Low Smoke Zero Halogen (LSZH) polyolefin boots meet low smoke and toxicity requirements of shipboard, transit and aircraft systems. Oxygen index greater than 30%, smoke index less than 20, and toxicity index under 3 per 100 grams. Material meets requirements of NAVSEA 5617649, VG95343 Part 29, BSG 198-5-DF, EN62329-101 and SAE AS5258 Type G. Good resistance to oils, fuels and solvents.

PRE-COATED ADHESIVE SELECTION GUIDE

- W1 Low Smoke Zero halogen (LSZH) polyamide hot melt adhesive Coating.** Bonds well to a variety of substrates. Good creep resistance at elevated temperatures. Excellent bond strength at low temperature. Good resistance to fuels and oils. -55°C to +125°C. Compatible with Type 1 and Type 2 boot materials.
- R High Temperature Epoxy Adhesive Coating.** Glenair's highest performance pre-coated adhesive. The material requires careful installation using trained operators. -75°C to 150°C. Withstands prolonged high temperature immersion in fuels and oils. Excellent peel adhesion on a wide range of materials. **Compatible with Type 1 boot material only.**

HOW TO ORDER

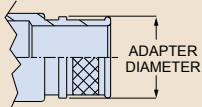
SERIES	MATERIAL	BOOT SIZE	ADHESIVE LINING																																																						
770-003S Heatshrink Boot, Lipped, Straight	1 High Performance Elastomer, Semi-Rigid, -75°C to +150°C 2 Low Smoke, Zero Halogen Polyolefin, Semi-Flexible, -30°C to +135°C	 Adapter Diameter <table border="1"> <thead> <tr> <th rowspan="2">Boot Size</th> <th colspan="2">Inches</th> <th colspan="2">mm.</th> </tr> <tr> <th>Min.</th> <th>Max.</th> <th>Min.</th> <th>Max.</th> </tr> </thead> <tbody> <tr><td>02</td><td>.350</td><td>.600</td><td>8.9</td><td>15.2</td></tr> <tr><td>03</td><td>.450</td><td>.850</td><td>11.4</td><td>21.6</td></tr> <tr><td>04</td><td>.600</td><td>1.000</td><td>15.2</td><td>25.4</td></tr> <tr><td>05</td><td>.750</td><td>1.200</td><td>19.1</td><td>30.5</td></tr> <tr><td>06</td><td>.900</td><td>1.350</td><td>22.9</td><td>34.3</td></tr> <tr><td>07</td><td>1.250</td><td>1.650</td><td>31.8</td><td>41.9</td></tr> <tr><td>08</td><td>1.400</td><td>2.250</td><td>35.6</td><td>57.2</td></tr> <tr><td>09</td><td>1.870</td><td>2.470</td><td>47.5</td><td>62.7</td></tr> <tr><td>10</td><td>2.400</td><td>3.250</td><td>61.0</td><td>82.6</td></tr> </tbody> </table>	Boot Size	Inches		mm.		Min.	Max.	Min.	Max.	02	.350	.600	8.9	15.2	03	.450	.850	11.4	21.6	04	.600	1.000	15.2	25.4	05	.750	1.200	19.1	30.5	06	.900	1.350	22.9	34.3	07	1.250	1.650	31.8	41.9	08	1.400	2.250	35.6	57.2	09	1.870	2.470	47.5	62.7	10	2.400	3.250	61.0	82.6	Omit for no adhesive lining. W1 Hot Melt Adhesive Low Smoke, Zero Halogen -55°C to +125°C R High Temperature Epoxy Adhesive -75°C to +150°C. Use with Type 1 High Performance Elastomer only. Not for use with Type 2 material.
				Boot Size	Inches		mm.																																																		
			Min.		Max.	Min.	Max.																																																		
			02	.350	.600	8.9	15.2																																																		
			03	.450	.850	11.4	21.6																																																		
			04	.600	1.000	15.2	25.4																																																		
			05	.750	1.200	19.1	30.5																																																		
			06	.900	1.350	22.9	34.3																																																		
			07	1.250	1.650	31.8	41.9																																																		
			08	1.400	2.250	35.6	57.2																																																		
09	1.870	2.470	47.5	62.7																																																					
10	2.400	3.250	61.0	82.6																																																					
SAMPLE PART NUMBER																																																									
770-003S	2	06	R																																																						



Series 970 PowerTrip™ Connectors and Accessories

Accessories

770-003S Heatshrink Boots

HEATSHRINK BOOT DIMENSIONS

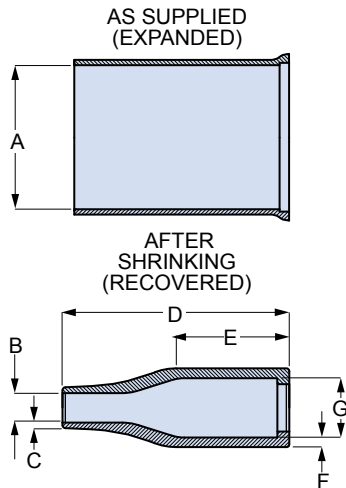

Boot Size	A Min.		B Max.		C ±20%		D ±10%		E Ref.		F ±30%		G Max.	
	In.	mm.	In.	mm.	In.	mm.	In.	mm.	In.	mm.	In.	mm.	In.	mm.
00	.354	9.0	.079	2.0	.028	0.7	.984	25.0	.551	14.0	.039	1.0	.217	5.5
01	.472	12.0	.118	3.0	.028	0.7	.984	25.0	.551	14.0	.043	1.1	.276	7.0
02	.669	17.0	.138	3.5	.028	0.7	1.181	30.0	.728	18.5	.051	1.3	.276	7.0
03	.945	24.0	.197	5.0	.035	0.9	1.496	38.0	.748	19.0	.063	1.6	.413	10.5
04	1.181	30.0	.236	6.0	.039	1.0	2.165	55.0	1.181	30.0	.071	1.8	.551	14.0
05	1.260	32.0	.276	7.0	.047	1.2	2.638	67.0	1.299	33.0	.071	1.8	.709	18.0
06	1.417	36.0	.335	8.5	.047	1.2	3.150	80.0	1.575	40.0	.079	2.0	.866	22.0
07	1.693	43.0	.394	10.0	.051	1.3	3.898	99.0	2.165	55.0	.087	2.2	1.102	28.0
08	2.362	60.0	.591	15.0	.063	1.6	5.118	130.0	1.969	50.0	.130	3.3	1.378	35.0
09	2.599	66.0	.661	16.8	.079	2.0	6.693	170.0	3.543	90.0	.150	3.8	1.752	44.5
10	3.400	86.4	1.060	26.9	.130	3.3	7.700	195.6	4.005	102.0	.160	4.1	2.250	57.2

BOOT IDENTIFICATION MARKING

Heatshrink boots are identified with molded-in lettering. This lettering shows the boot type, boot size and orientation. Position the boot so that the lipped "A" end is toward the adapter and the "C" end is toward the cable. Assembly instructions are in the **Series 77 "Full Nelson" Environmental Shrink Boots** catalog, available at www.glenair.com.

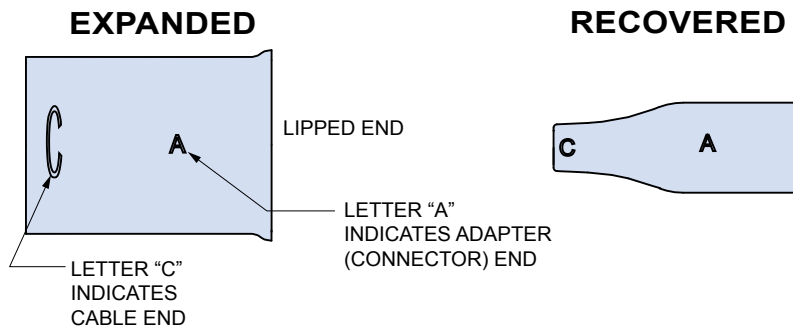

USER-INSTALLED BOOT ADHESIVE, DISPENSING GUN AND MIXING NOZZLE



Part Number
779-001



Part Number
779-002



Part Number	Count Per Pack
779-003	12

High performance flexible two part thermoset epoxy provides high strength flexible bond from -55° to 150°C. 50 ml duo syringe fits standard dispensing guns. Use with square green mixing nozzle sold separately. 12 hour cure time at 20°C, 1 hour at 85°C, 30 minutes at 150°C. Apply to inside of boot with wooden spatula. 18 month shelf life.

Twin push-rod 1:1 ratio epoxy dispensing gun for use with duo syringe epoxy and mixing nozzle sold separately. Durable heavy-duty plastic. Gun type hand grip with ratcheting trigger to advance push-rods.

1:1 ratio mixing nozzle attaches to duo syringe with 1/2 turn and locks into place. Nozzle provides consistent mixing of resin and hardener. Kit consists of (12) nozzles.

X-ON Electronics

Largest Supplier of Electrical and Electronic Components

Click to view similar products for [Heat Shrink Tubing and Sleeves](#) category:

Click to view products by [Glenair](#) manufacturer:

Other Similar products are found below :

[770-006S102](#) [5685710001](#) [CR8248-000](#) [CR9960-000](#) [603312-4](#) [607381P039](#) [611112-000](#) [617867N001](#) [6500750004](#) [CZ1420-000](#) [D-306-38](#)
[770-003S106W2](#) [770-005S105W1](#) [770-005S106W1](#) [770-007A303](#) [770-010Y106W1](#) [770-010Y706W1](#) [7771210001](#) [MFP-1/4"-Clear](#) [MFP-3/64"-Clear](#) [790-3012](#) [MFT-MT2000-NO.14-0-SP](#) [MHHT-4-15K2-G-104](#) [MIL-LT-1-1/2-4-SP](#) [MIL-LT-1-1/2-9-STK](#) [MIL-LT-1/2-2-STK](#)
[MIL-LT-3-0-SP](#) [MIL-LT-3/32-0-SP](#) [MIL-LT-3/32-6-SP](#) [MIL-LT-3/4-6-SP](#) [MIL-LT-3/8-0-SP](#) [8159270001](#) [839602-000](#) [8423-6](#) [FP301-116-6"-Black](#) [FP301-1/2-48"-Black](#) [FP301-12-48"-Black-Hdr](#) [FP301-1/4-48"-Black](#) [FP301-1/4-48"-White-Hdr](#) [FP301-1-6"-Clear](#) [FP301-18-48"-Black-Hdr](#) [FP301-1/8-6"-Black](#) [FP301-18-6"-Black-Bulk](#) [FP301-316-48"-Blue-Hdr](#) [FP301-316-6"-Clear](#) [FP301-332-6"-Black](#) [912229N002](#)
[120-126-16BL](#) [121-001-09](#) [121-018-32](#)