



400PSM-CR

SMA Male for CNT-400 braided cable

## General Specifications

---

Interface	SMA Male
Body Style	Straight
Brand	CNT®

## Electrical Specifications

---

Operating Frequency Band	0 – 6000 MHz
Cable Impedance	50 ohm
Connector Impedance	50 ohm
RF Operating Voltage, maximum (vrms)	500.00 V
dc Test Voltage	1000 V
Outer Contact Resistance, maximum	2.50 mOhm
Inner Contact Resistance, maximum	3.00 mOhm
Insulation Resistance, minimum	5000 MOhm
Average Power	580.0 W @ 900 MHz
Peak Power, maximum	5.00 kW
Insertion Loss, typical	0.05 dB

400PSM-CR

## Outline Drawing

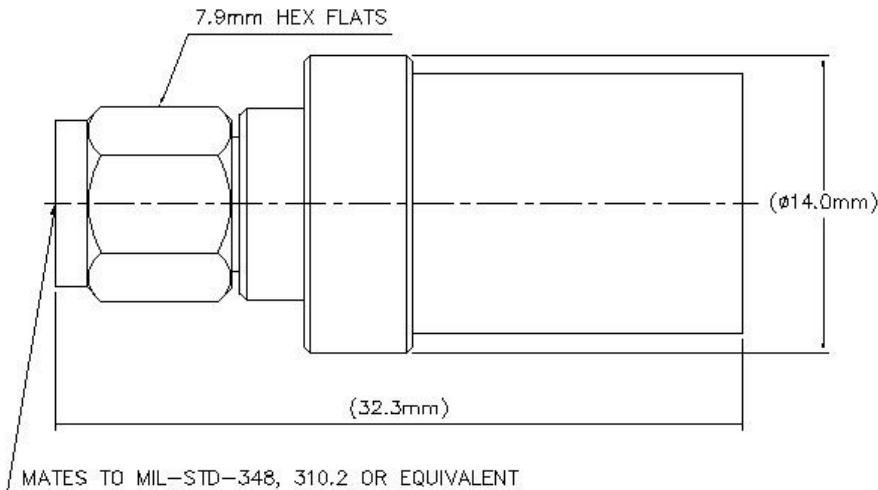

## Mechanical Specifications

Outer Contact Plating	Trimetal
Inner Contact Plating	Gold
Outer Contact Attachment Method	Crimp
Inner Contact Attachment Method	Solder
Interface Durability	500 cycles
Interface Durability Method	IEC 61169-15:9.5
Connector Retention Tensile Force	330 N   74 lbf
Connector Retention Torque	0.75 N-m   0.56 N-m
Insertion Force	22.00 N   4.95 lbf
Insertion Force Method	IEC 61169-15:9.3.5
Pressurizable	No
Coupling Nut Proof Torque	1.70 N-m   1.25 ft lb
Coupling Nut Proof Torque Method	IEC 61169-15:9.3.6
Coupling Nut Retention Force	180.00 N   40.47 lbf
Coupling Nut Retention Force Method	IEC 61169-15:9.3.11

## Dimensions

Nominal Size	0.405 in
Diameter	14.00 mm   0.55 in
Length	32.32 mm   1.27 in
Weight	16.00 g   0.04 lb
Width	14.00 mm   0.55 in

## Environmental Specifications

Operating Temperature	-40 °C to +85 °C (-40 °F to +185 °F)
-----------------------	--------------------------------------

400PSM-CR

Storage Temperature	-65 °C to +125 °C (-85 °F to +257 °F)
Water Jetting Test Mating	Mated
Water Jetting Test Method	IEC 60529:2001, IP65
Mechanical Shock Test Method	IEC 60068-2-27
Climatic Sequence Test Method	IEC 60068-1
Damp Heat Steady State Test Method	IEC 60068-2-3
Thermal Shock Test Method	IEC 60068-2-14
Vibration Test Method	IEC 60068-2-6
Corrosion Test Method	IEC 60068-2-11

## Standard Conditions

Attenuation, Ambient Temperature	20 °C   68 °F
Average Power, Ambient Temperature	40 °C   104 °F
Average Power, Inner Conductor Temperature	100 °C   212 °F

## Return Loss/VSWR

Frequency Band	VSWR	Return Loss (dB)
0–3000 MHz	1.07	30.00
3000–6000 MHz	1.08	28.10

## Regulatory Compliance/Certifications

Agency	Classification
RoHS 2011/65/EU	Compliant by Exemption
China RoHS SJ/T 11364-2006	Above Maximum Concentration Value (MCV)
ISO 9001:2008	Designed, manufactured and/or distributed under this quality management system



## \* Footnotes

Insertion Loss, typical 0.05v<sup>-</sup>freq (GHz) (not applicable for elliptical waveguide)

## X-ON Electronics

Largest Supplier of Electrical and Electronic Components

*Click to view similar products for [RF Adapters - Between Series category:](#)*

*Click to view products by [Commscope manufacturer:](#)*

Other Similar products are found below :

[R191203007](#) [R191209000](#) [R191212000](#) [R191215000](#) [R191301000](#) [R191325000](#) [R191389200](#) [R191403000](#) [R191405000](#) [R191416000](#)  
[R191419000](#) [R191421000](#) [R191424000](#) [R191445000](#) [R191511000](#) [R191552000](#) [R191720000](#) [R191722000](#) [R191733000](#) [R191759000](#)  
[R191841001W](#) [R191911000](#) [R191912000](#) [R191968001W](#) [R192417010](#) [R921390000](#) [ADBJ20-E1-BJ379](#) [ADM2](#) [ADPL75-A1-PL75](#)  
[ADPL75-E1-UBJ20](#) [9317505](#) [931RPBUFLP](#) [AD130](#) [ADBJ20-E1-PL74](#) [ADBJ20-E2-BJ79](#) [ADBJ77-A1PL3155](#) [ADBJ77-E1-UPL20](#)  
[ADBJ77-E2-PL20](#) [242215](#) [242228](#) [CP-AD851](#) [R125680000W](#) [R191117000](#) [R191123000](#) [R191.147.000](#) [R191303000](#) [R191313000](#)  
[R191315000](#) [R191316700](#) [R191327000](#)