

SMD Inductors(Coils) For Power Line(Wound, Magnetic Shielded)

Conformity to RoHS Directive

VLF Series VLF10045

FEATURES

- Mount area: 9.7×10.0mm
Low profile: 4.5mm max. height
- Compare to SLF10145(TDK conventional product) type
Low loss and large current capability design
DC resistance: 0.89×SLF10145
Rated DC current: 1.47×SLF10145
- Generic use for DC to DC converter line.
- High magnetic shield construction should actualize high resolution for EMC protection.
- Available for automatic mounting in tape and reel package.
- The products contain no lead and also support lead-free soldering.
- It is a product conforming to RoHS directive.

APPLICATIONS

Note book computers, amusement equipment, DVD players, VRMs, plasma displays, etc.

SHAPES AND DIMENSIONS

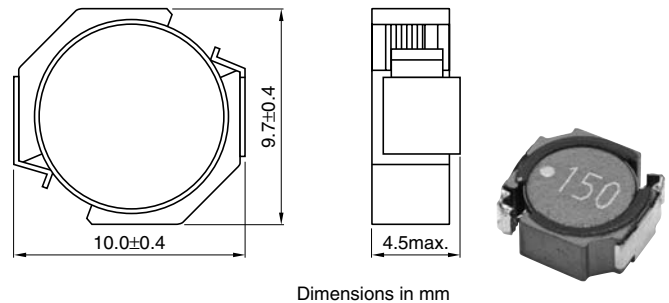

Dimensions in mm

RECOMMENDED PC BOARD PATTERN

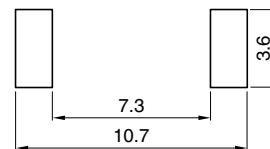

Dimensions in mm

ELECTRICAL CHARACTERISTICS

Part No.	Inductance (μH)	Inductance tolerance(%)	Test frequency (kHz)	DC resistance(mΩ)		Rated current(A)*	
				max.	typ.	Based on inductance change max.	Based on temperature rise typ.
VLF10045T-1R0N100	1.0	±30	100	5.5	4.6	13.5	10
VLF10045T-1R5N9R0	1.5	±30	100	6.8	5.7	11.1	9
VLF10045T-2R2N7R4	2.2	±30	100	10.2	8.5	9.1	7.4
VLF10045T-3R3N6R9	3.3	±30	100	11.6	9.7	7.5	6.9
VLF10045T-4R7N6R1	4.7	±30	100	15	12.5	6.3	6.1
VLF10045T-6R8N5R1	6.8	±30	100	21.4	17.8	5.2	5.1
VLF10045T-100M4R3	10	±20	100	29	25.0	4.3	4.3
VLF10045T-150M3R5	15	±20	100	43	37.3	3.5	3.5
VLF10045T-220M2R8	22	±20	100	57	49.5	2.8	3.0
VLF10045T-330M2R3	33	±20	100	81	70.1	2.3	2.6
VLF10045T-470M1R9	47	±20	100	112	97.6	1.9	2.2
VLF10045T-680M1R6	68	±20	100	182	158	1.6	1.7
VLF10045T-101M1R3	100	±20	100	250	217	1.3	1.4
VLF10045T-151M1R1	150	±20	100	352	306	1.1	1.2
VLF10045T-221MR90	220	±20	100	499	434	0.9	1.0
VLF10045T-331MR70	330	±20	100	829	721	0.7	0.8

* Rated current: Value obtained when current flows and the temperature has risen to 40°C or when DC current flows and the nominal value of inductance has fallen by 30%, whichever is smaller.

- Operating temperature range: -40 to +105°C (Including self-temperature rise)

• Conformity to RoHS Directive: This means that, in conformity with EU Directive 2002/95/EC, lead, cadmium, mercury, hexavalent chromium, and specific bromine-based flame retardants, PBB and PBDE, have not been used, except for exempted applications.

• All specifications are subject to change without notice.

X-ON Electronics

Largest Supplier of Electrical and Electronic Components

Click to view similar products for [Fixed Inductors](#) category:

Click to view products by [TDK](#) manufacturer:

Other Similar products are found below :

[MLZ1608M6R8WTD25](#) [MLZ1608N6R8LT000](#) [MLZ1608N3R3LTD25](#) [MLZ1608N3R3LT000](#) [MLZ1608N150LT000](#)

[MLZ1608M150WTD25](#) [MLZ1608M3R3WTD25](#) [MLZ1608M3R3WT000](#) [MLZ1608M150WT000](#) [MLZ1608A1R5WT000](#)

[MLZ1608N1R5LT000](#) [B82432C1333K000](#) [PCMB053T-1R0MS](#) [PCMB053T-1R5MS](#) [PCMB104T-1R5MS](#) [CR32NP-100KC](#) [CR32NP-](#)

[151KC](#) [CR32NP-180KC](#) [CR32NP-181KC](#) [CR32NP-1R5MC](#) [CR32NP-390KC](#) [CR32NP-3R9MC](#) [CR32NP-680KC](#) [CR32NP-820KC](#)

[CR32NP-8R2MC](#) [CR43NP-390KC](#) [CR43NP-560KC](#) [CR43NP-680KC](#) [CR54NP-181KC](#) [CR54NP-470LC](#) [CR54NP-820KC](#) [CR54NP-8R5MC](#)

[MGDQ4-00004-P](#) [MGDU1-00016-P](#) [MHL1ECTTP18NJ](#) [MHL1JCTTD12NJ](#) [PE-51506NL](#) [PE-53601NL](#) [PE-53630NL](#) [PE-53824SNLT](#) [PE-](#)

[62892NL](#) [PE-92100NL](#) [PG0434.801NLT](#) [PG0936.113NLT](#) [PM06-2N7](#) [PM06-39NJ](#) [HC2LP-R47-R](#) [HC2-R47-R](#) [HC3-2R2-R](#) [HC8-1R2-R](#)