

L-914Hx BRIGHT RED	L-914Gx GREEN
L-914Ix HIGH EFFICIENCY RED	L-914Ex ORANGE
L-914PGT PURE GREEN	L-914Ax YELLOW

Features

- LOW POWER CONSUMPTION.
- ULTRA BRIGHTNESS IS AVAILABLE .
- RELIABLE AND RUGGED.
- EXCELLENT UNIFORMITY OF LIGHT OUTPUT.
- SUITABLE FOR LEVEL INDICATOR.

Description

The Bright Red source color devices are made with Gallium Phosphide Red Light Emitting Diode.

The High Efficiency Red and Orange source color devices are made with Gallium Arsenide Phosphide on Gallium Phosphide Orange Light Emitting Diode.

The Green source color devices are made with Gallium Phosphide Green Light Emitting Diode.

The Yellow source color devices are made with Gallium Arsenide Phosphide on Gallium Phosphide Yellow Light Emitting Diode.

The Pure Green source color devices are made with Gallium Phosphide Green Light Emitting Diode.

Package Dimensions

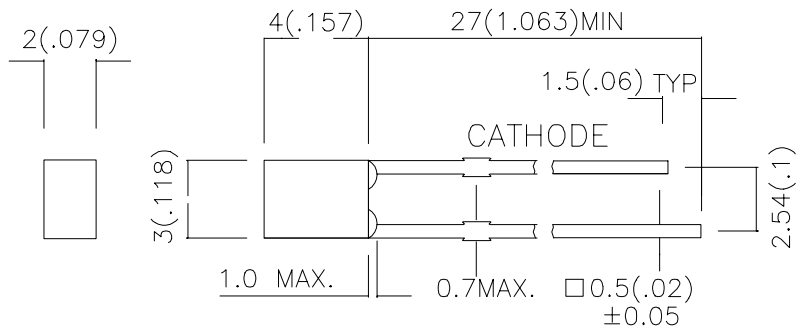

Notes:

1. All dimensions are in millimeters (inches).
2. Tolerance is $\pm 0.25(0.01)$ unless otherwise noted.
3. Lead spacing is measured where the lead emerge package.
4. Specifications are subject to change without notice.

Selection Guide

Part No.	Dice	Lens Type	Iv (mcd) @ 10 mA		Viewing Angle
			Min.	Typ.	2θ1/2
L-914HD	BRIGHT RED (GaP)	RED DIFFUSED	0.2	1	100°
L-914HT	BRIGHT RED (GaP)	RED TRANSPARENT	0.5	1	90°
L-914ID	HIGH EFFICIENCY RED (GaAsP/GaP)	RED DIFFUSED	2	8	100°
L-914IT	HIGH EFFICIENCY RED (GaAsP/GaP)	RED TRANSPARENT	3	8	90°
L-914ED	ORANGE (GaAsP/GaP)	ORANGE DIFFUSED	2	8	100°
L-914ET	HIGH EFFICIENCY RED (GaAsP/GaP)	ORANGE TRANSPARENT	3	8	90°
L-914GD	GREEN (GaP)	GREEN DIFFUSED	2	6	100°
L-914GT	GREEN GaP)	GREEN TRANSPARENT	3	8	90°
L-914AD	YELLOW(GaAsP/GaP)	AMBER DIFFUSED	2	5	100°
L-914AT	YELLOW (GaAsP/GaP)	AMBER TRANSPARENT	2	7	90°
L-914PGT	PURE GREEN (GaP)	GREEN TRANSPARENT	0.5	1	90°

Note:

1. θ1/2 is the angle from optical centerline where the luminous intensity is 1/2 the optical centerline value.

Electrical / Optical Characteristics at T_A=25°C

Symbol	Parameter	Device	Typ.	Max.	Units	Test Conditions
λ _{peak}	Peak Wavelength	Bright Red High Efficiency Red Orange Green Yellow Pure Green	700 627 627 565 590 555		nm	IF=20mA
λ _D	Dominate Wavelength	Bright Red High Efficiency Red Orange Green Yellow Pure Green	660 625 625 568 588 555		nm	IF=20mA
Δλ _{1/2}	Spectral Line Halfwidth	Bright Red High Efficiency Red Orange Green Yellow Pure Green	45 45 45 30 35 30		nm	IF=20mA
C	Capacitance	Bright Red High Efficiency Red Orange Green Yellow Pure Green	40 15 15 15 20 45		pF	VF=0V;f=1MHz
V _F	Forward Voltage	Bright Red High Efficiency Red Orange Green Yellow Pure Green	2.25 2.0 2.0 2.2 2.1 2.25	2.5 2.5 2.5 2.5 2.5 2.5	V	IF=20mA
I _R	Reverse Current	All		10	uA	VR = 5V

Absolute Maximum Ratings at $T_A=25^\circ\text{C}$

Parameter	Bright Red	High Efficiency Red	Orange	Green	Yellow	Pure Green	Units
Power dissipation	120	105	105	105	105	105	mW
DC Forward Current	25	30	30	25	30	25	mA
Peak Forward Current [1]	120	160	160	140	140	135	mA
Reverse Voltage	5	5	5	5	5	5	V
Operating/Storage Temperature	-40°C To +85°C						
Lead Solder Temperature [2]	260°C For 5 Seconds						

Notes:

- 1/10 Duty Cycle, 0.1ms Pulse Width.
- 4mm below package base.

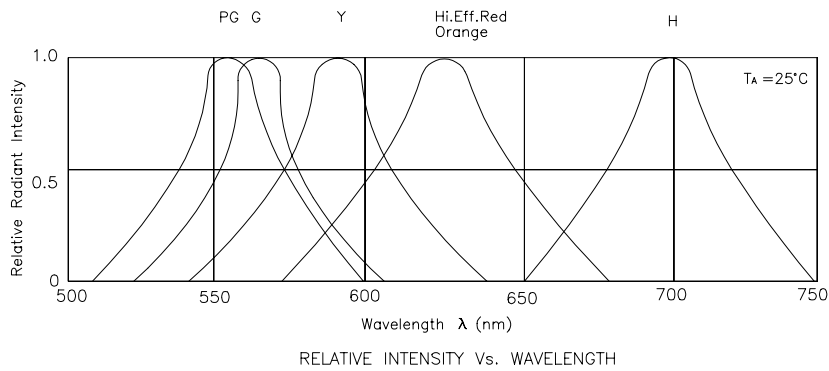

Bright Red L-914HD,L-914HT

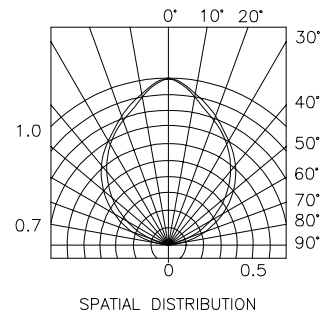
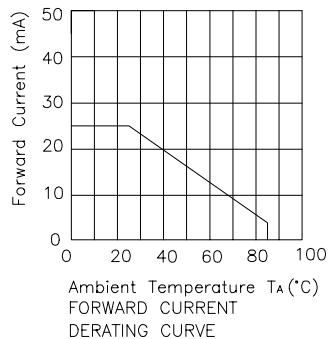
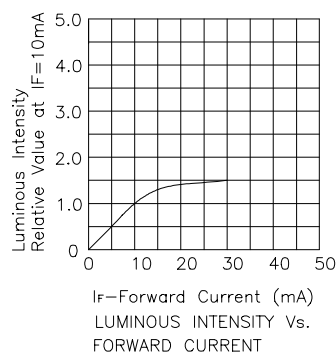
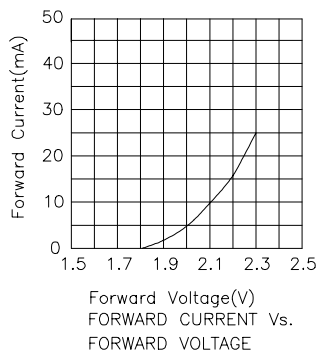

High Efficiency Red L-914ID,L-914IT

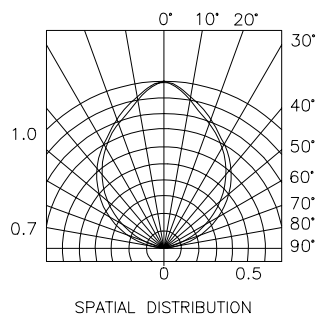
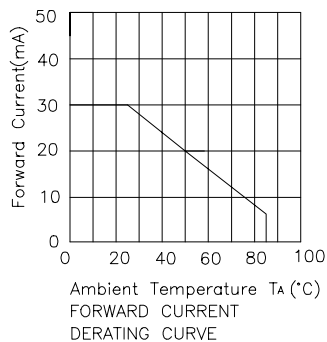
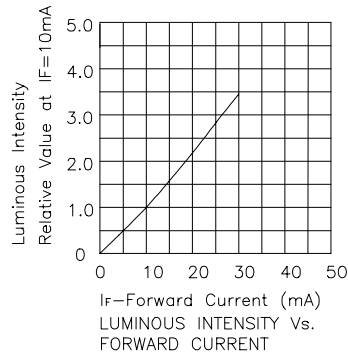
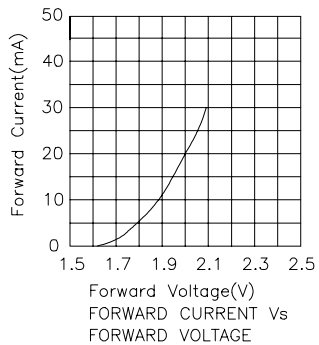

Orange L-914ED,L-914ET

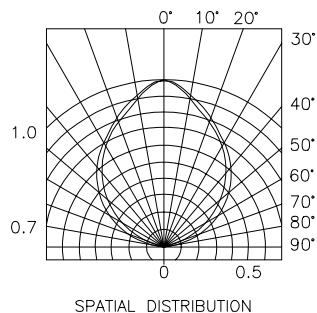
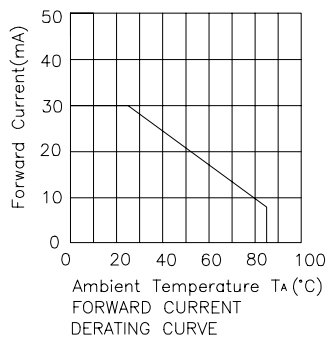
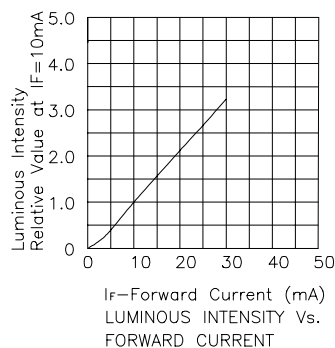
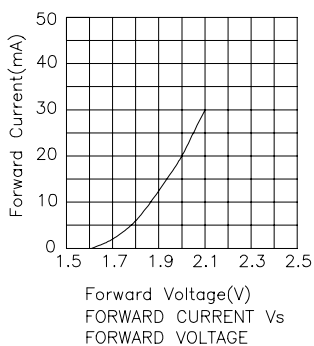

Green L-914GD, L-914GT

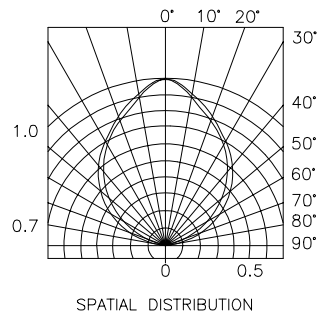
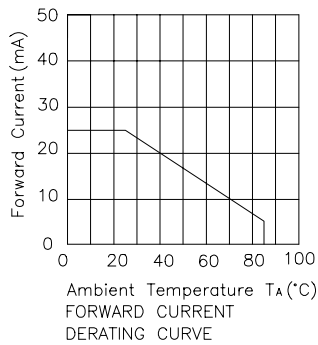
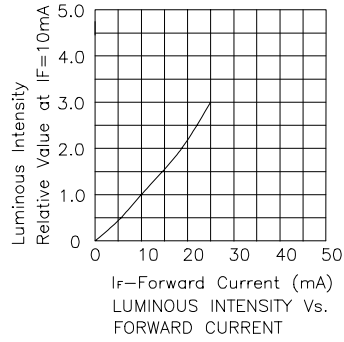
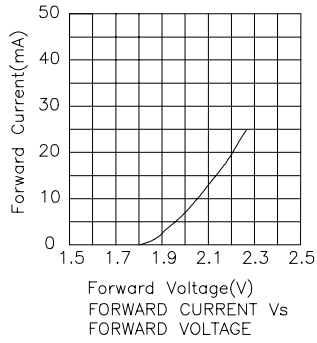

Yellow L-914AD, L-914AT

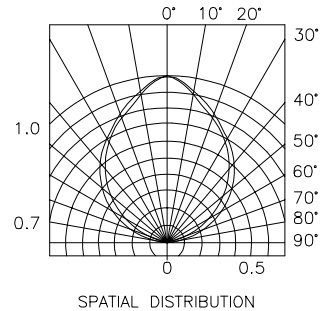
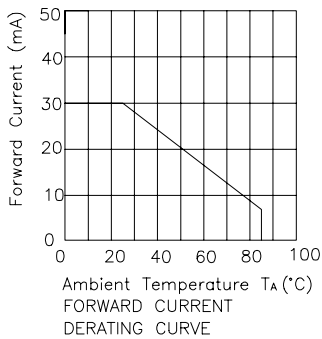
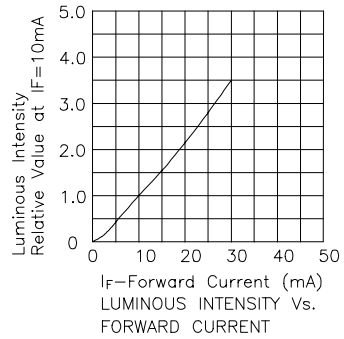
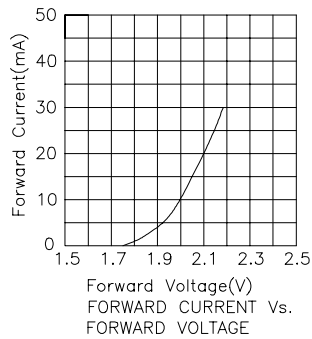

Pure Green L-914PGT

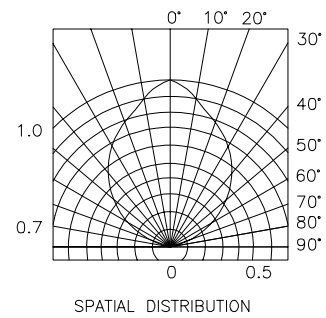
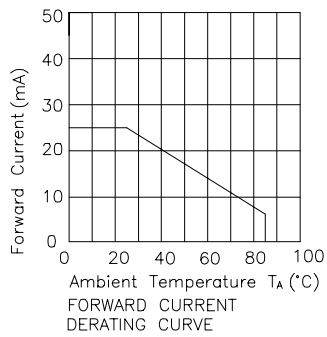
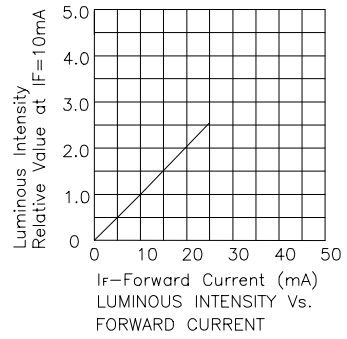
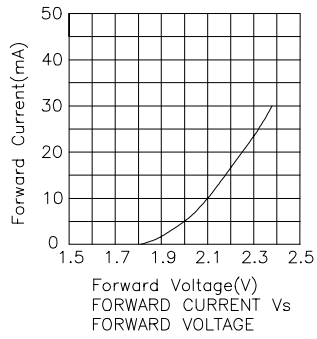

X-ON Electronics

Largest Supplier of Electrical and Electronic Components

Click to view similar products for [Standard LEDs - Through Hole category](#):

Click to view products by [Kingbright manufacturer](#):

Other Similar products are found below :

[LTL-10254W](#) [LTL-1214A](#) [LTL-1BEDJ](#) [LTL-2231AT](#) [LTL-3251A](#) [LTL-4262N](#) [LTL-5234](#) [LTL87HTBK](#) [LTD-87HD4B](#) [7383/V7C3-BSTA-L/PR3/MS](#) [G22041431007J2C000](#) [HLMP-AG64-X10ZZ](#) [HLMP-EG1A-Z10DV](#) [HLMP-EL3B-WXKDD](#) [HLMP-HB74-UVBDD](#) [HLMP-HG65-VY0DD](#) [HLMP-HM74-34CDD](#) [HLMP-HM75-34CDD](#) [1L0532V23G0TD001](#) [NSPW500CS](#) [C4SMA-BGF-CQ34Q3C2](#) [L53GC13](#) [264-7SURTS530-A3](#) [L-C150JRCT](#) [S4SMS-BJF-CQ42QGF2](#) [S4SMS-GJF-CW12QMF2](#) [LD CQDP-1U3U-W5-1-K](#) [LNX998CKBDA](#) [LO566UHR3-70G-A3](#) [SLA560WBD2PT3](#) [LP379PPG1C0G0300001](#) [SLR-322MCT32](#) [SLR-342DUT32](#) [SLR-342MC3F](#) [SLR343BC7TT32](#) [SLR343BCTT32](#) [SLX-LX3044GD](#) [SLX-LX3044ID](#) [SLX-LX3044YD](#) [SNW-LX504SRC/4](#) [1.90690.3330000](#) [SSL-LX20483ID](#) [SSL-LX3034YD](#) [SSL-LX5093LGT-11](#) [SSL-LX5093PGC](#) [SSL-LX5093SRC/F](#) [SSL-LX5093SYT](#) [SSL-LX5099SRSGC-CA](#) [SSL-LX509E3SIT](#) [SSL-LX509FT3ID](#)