



ON Semiconductor®

<http://onsemi.com>

# LA6581DM

Monolithic Linear IC

Fan Motor Driver

## BLT Driver Single-Phase Full-Wave

### Overview

The LA6581DM is a low-saturation BTL output linear driving motor driver for single-phase bipolar fan motors. It features quite, low power, high efficiency drive that suppresses reactive current. It is optimal for use in applications that require miniaturization and low noise, such as CPU cooling fan motors and 5 to 12V electronic game products.

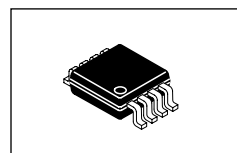

Micro8

### Functions

- Single-phase full-wave linear drive with BTL output (gain resistance 500Ω to 284kΩ, 55dB) : Suitable for the equipment requiring silent operation, such as game equipment, CPU cooler, etc. because of its freedom from switching noise.
- Low-voltage operation possible, with wide operable voltage range (2.2 to 16V)
- Low saturation output (Upper + lower saturation voltage :  $V_{O\text{sat}}$  (total) = 0.3V typ,  $I_O = 100\text{mA}$ ) : High coil efficiency with low current drain. IC itself does not generate much heat.
- High impedance of Hall input pin
- FG output (rotation speed detection output : open collector output)
- Heat protection circuit : When the large current flows because of output short-circuit, raising the IC chip temperature above 180°C, the heat protection circuit suppresses the drive current, preventing IC burn and breakdown.
- Extra-small package (Micro8)  
Small substrate while allowing larger blades

### Specifications

Maximum Ratings at  $T_a = 25^\circ\text{C}$ 

Parameter	Symbol	Conditions	Ratings	Unit
Output voltage	$V_{CC\text{ max}}$		18	V
Allowable power dissipation	$P_d\text{ max}$	Mounted on a specified board *1	400	mW
Output current	$I_{O\text{UT}1\text{ max}}$	*2	0.36	A
	$I_{O\text{UT}2\text{ max}}$	$T < 200\text{ms}$	0.50	A
Output withstand voltage	$V_{O\text{UT}\text{ max}}$		18	V
FG output withstand	$V_{FG\text{ max}}$		18	V
FG output current	$I_{FG\text{ max}}$		5	mA
Operating temperature	$T_{opr}$		-30 to +100	°C
Storage temperature	$T_{stg}$		-55 to +150	°C

\*1: Mounted on a board (20.0mm 10.0mm 0.8mm: Paper Phenol, wiring density 20%)

\*2: This specifies the starting current.  $T_j = 15^\circ\text{C}$  max must not be exceeded..

Caution 1) Absolute maximum ratings represent the value which cannot be exceeded for any length of time.

Caution 2) Even when the device is used within the range of absolute maximum ratings, as a result of continuous usage under high temperature, high current, high voltage, or drastic temperature change, the reliability of the IC may be degraded. Please contact us for the further details.

Stresses exceeding Maximum Ratings may damage the device. Maximum Ratings are stress ratings only. Functional operation above the Recommended Operating Conditions is not implied. Extended exposure to stresses above the Recommended Operating Conditions may affect device reliability.

### ORDERING INFORMATION

See detailed ordering and shipping information on page 5 of this data sheet.

# LA6581DM

## Recommended Operating Conditions at $T_a = 25^\circ\text{C}$

Parameter	Symbol	Conditions	Ratings	Unit
Supply voltage	$V_{CC}$		2.2 to 16	V
Common-phase input voltage range of Hall input	$V_{ICM}$		0.3 to $V_{CC}-1.5$	V

## Electrical Characteristics at $T_a = 25^\circ\text{C}$ , $V_{CC} = 12.0\text{V}$ , unless especially specified.

Parameter	Symbol	Conditions	Ratings			Unit
			min	Typ	Max	
Circuit Current	$I_{CC}$	$IN^- = 5.8\text{V}$ , $IN^+ = 6.0\text{V}$ , $R_L = \infty$		14	19	mA
OUT output low voltage	$V_{OL}$	$I_O = 100\text{mA}$		0.1	0.2	V
OUT output high voltage	$V_{OH}$	$I_O = 100\text{mA}$		0.1	0.2	V
Hall bias voltage	$V_{HB}$	$RH = 360\Omega + 91\Omega$	1.85	1.95	2.05	V
Hall amplifier gain	$V_g$		52	55	58	dB
Hall amplifier input current	$V_{INR}$		-10	-2	+10	$\mu\text{A}$
FG output low voltage	$V_{FG}$	$I_{FG} = 3\text{mA}$		0.2	0.3	V
FG output leakage current	$I_{FGL}$	$V_{FG} = 7\text{V}$			30	$\mu\text{A}$
Thermal protection circuit	Th	* Design guarantee	150	180	200	$^\circ\text{C}$

\*: These values are design guarantee values, and are not tested.

## Truth Table

$IN^-$	$IN^+$	OUT1	OUT2	FG	mode
H	L	H	L	L	During rotation
L	H	L	H	Off	
-	-	Off	Off	-	During overheat protection

## Pd-Ta

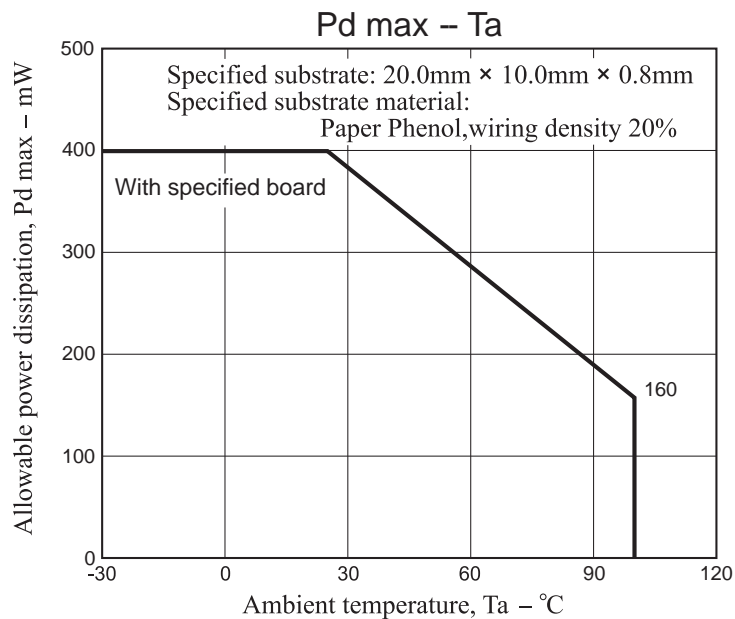

Package Dimensions

unit : mm (typ)

Micro8

CASE 846A-02

ISSUE J

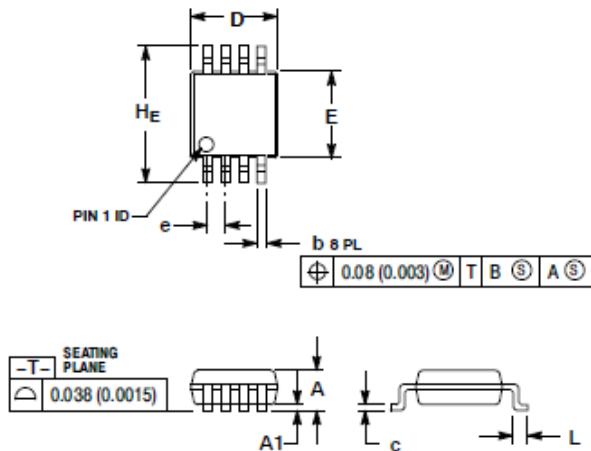

NOTES:

1. DIMENSIONING AND TOLERANCING PER ANSI Y14.5M, 1982.
2. CONTROLLING DIMENSION: MILLIMETER.
3. DIMENSION A DOES NOT INCLUDE MOLD FLASH, PROTRUSIONS OR GATE BURRS. MOLD FLASH, PROTRUSIONS OR GATE BURRS SHALL NOT EXCEED 0.15 (0.008) PER SIDE.
4. DIMENSION B DOES NOT INCLUDE INTERLEAD FLASH OR PROTRUSION. INTERLEAD FLASH OR PROTRUSION SHALL NOT EXCEED 0.25 (0.010) PER SIDE.
5. 846A-01 OBSOLETE, NEW STANDARD 846A-02.

DIM	MILLIMETERS			INCHES		
	MIN	NOM	MAX	MIN	NOM	MAX
A	--	--	1.10	--	--	0.043
A1	0.05	0.08	0.15	0.002	0.003	0.008
b	0.25	0.33	0.40	0.010	0.013	0.018
e	0.13	0.18	0.23	0.005	0.007	0.009
D	2.90	3.00	3.10	0.114	0.118	0.122
E	2.90	3.00	3.10	0.114	0.118	0.122
e	0.65 BSC			0.026 BSC		
L	0.40	0.56	0.70	0.016	0.021	0.028
Hc	4.75	4.90	5.05	0.187	0.193	0.199

GENERIC MARKING DIAGRAM\*

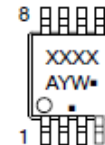

- XXXX = Specific Device Code
  - A = Assembly Location
  - Y = Year
  - W = Work Week
  - = Pb-Free Package
- (Note: Microdot may be in either location)

\*This information is generic. Please refer to device data sheet for actual part marking. Pb-Free indicator, "G" or microdot "•", may or may not be present.

RECOMMENDED SOLDERING FOOTPRINT\*

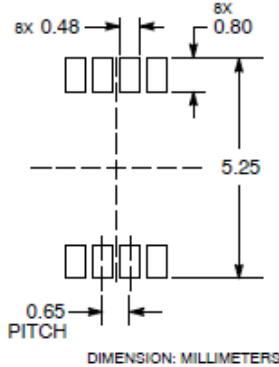

\*For additional information on our Pb-Free strategy and soldering details, please download the ON Semiconductor Soldering and Mounting Techniques Reference Manual, SOLDERRM/D.

STYLE 1: PIN 1. SOURCE 2. SOURCE 3. SOURCE 4. GATE 5. DRAIN 6. DRAIN 7. DRAIN 8. DRAIN	STYLE 2: PIN 1. SOURCE 1 2. GATE 1 3. SOURCE 2 4. GATE 2 5. DRAIN 2 6. DRAIN 2 7. DRAIN 1 8. DRAIN 1	STYLE 3: PIN 1. N-SOURCE 2. N-GATE 3. P-SOURCE 4. P-GATE 5. P-DRAIN 6. P-DRAIN 7. N-DRAIN 8. N-DRAIN
--	--	--

Pin Assignment

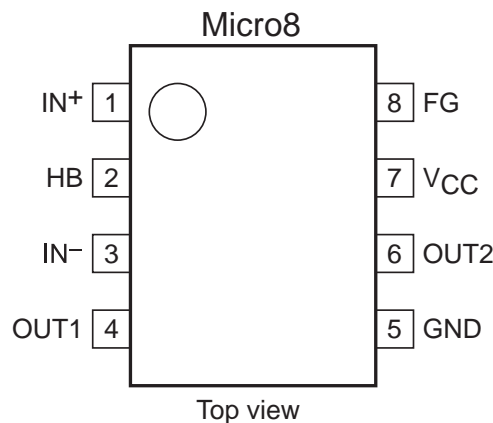

# LA6581DM

## Block Diagram

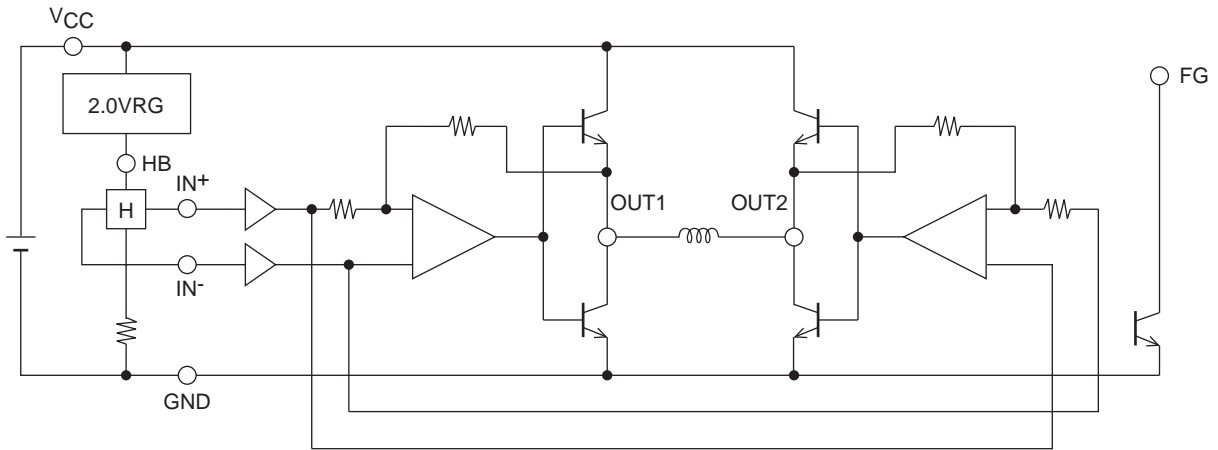

## Timing Chart

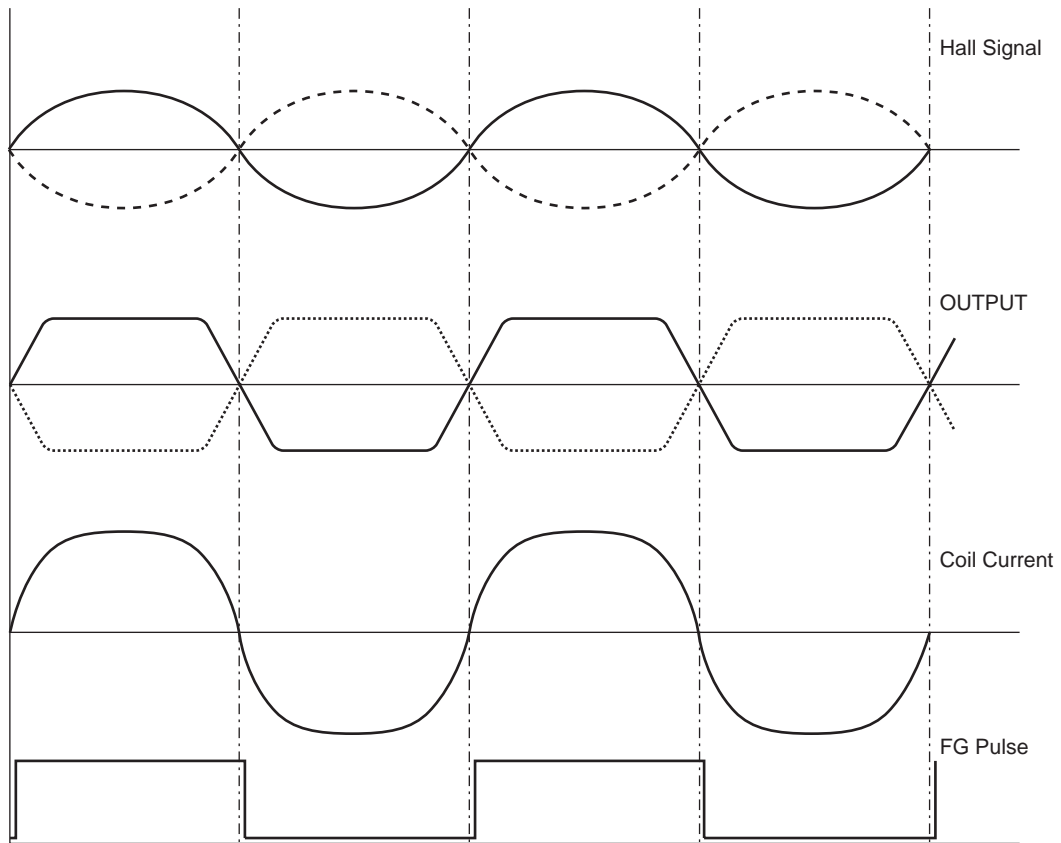



## X-ON Electronics

Largest Supplier of Electrical and Electronic Components

*Click to view similar products for [Motor/Motion/Ignition Controllers & Drivers](#) category:*

*Click to view products by [ON Semiconductor](#) manufacturer:*

Other Similar products are found below :

[LV8133JA-ZH](#) [LV8169MUTBG](#) [LV8774Q-AH](#) [LV8860PV-TLM-H](#) [MC33931EKR2](#) [FSB50250UTD](#) [FSB50550TB2](#) [FSBF15CH60BTH](#)  
[FSBS10CH60T](#) [MP6507GR-P](#) [MP6508GF](#) [MSVCPM2-63-12](#) [MSVGW45-14-2](#) [MSVGW54-14-5](#) [NTE7043](#) [CAT3211MUTAG](#) [LA6245P-CL-TLM-E](#) [LA6245P-TLM-E](#) [LA6565VR-TLM-E](#) [LB11650-E](#) [LB1694N-E](#) [LB1837M-TLM-E](#) [LB1845DAZ-XE](#) [LC898111AXB-MH](#)  
[LC898300XA-MH](#) [SS30-TE-L-E](#) [STK531-345A-E](#) [STK581U3A0D-E](#) [STK58AUNP0D-E](#) [STK621-068C-E](#) [STK621-140C](#) [STK621-728S-E](#)  
[STK625-728-E](#) [STK672-400B-E](#) [STK672-432AN-E](#) [STK672-432BN-E](#) [STK672-440AN-E](#) [STK672-442AN-E](#) [AMIS30621AUA](#)  
[FSB50550ASE](#) [26700](#) [LV8161MUTAG](#) [LV8281VR-TLM-H](#) [LV8702V-TLM-H](#) [LV8734VZ-TLM-H](#) [LV8773Z-E](#) [LV8807QA-MH](#)  
[MC33932EK](#) [MCP8024T-H/MP](#) [TND027MP-AZ](#)