



SMSC[®]
SUCCESS BY DESIGN

LAN8741/LAN8741i

Small Footprint MII/RMII 10/100 Energy Efficient Ethernet Transceiver with HP Auto-MDIX and flexPWR[®] Technology



PRODUCT FEATURES

Data Brief

Highlights

- Single-Chip Ethernet Physical Layer Transceiver (PHY)
- Compliant with Energy Efficient Ethernet 802.3az
- Comprehensive flexPWR[®] technology
 - Flexible power management architecture
 - LVCMOS Variable I/O voltage range: +1.8 V to +3.3 V
 - Integrated 1.2 V regulator with disable feature

Target Applications

- Set-Top Boxes
- Networked Printers and Servers
- Test Instrumentation
- LAN on Motherboard
- Embedded Telecom Applications
- Video Record/Playback Systems
- Cable Modems/Routers
- DSL Modems/Routers
- Digital Video Recorders
- IP and Video Phones
- Wireless Access Points
- Digital Televisions
- Digital Media Adaptors/Servers
- Gaming Consoles
- POE Applications (Refer to SMSC Application Note 17.18)

Key Benefits

- High-performance 10/100 Ethernet transceiver
 - Compliant with IEEE 802.3/802.3u (Fast Ethernet)
 - Compliant with ISO 802-3/IEEE 802.3 (10BASE-T)
 - Compliant with Energy Efficient Ethernet IEEE 802.3az
 - Loop-back modes
 - Auto-negotiation
 - Automatic polarity detection and correction
 - Link status change wake-up detection
 - Vendor specific register functions
 - Supports both MII and the reduced pin count RMII interfaces
- Power and I/Os
 - Various low power modes
 - Integrated power-on reset circuit
 - Two status LED outputs
 - May be used with a single 3.3 V supply
- Additional Features
 - Ability to use a low cost 25 MHz crystal for reduced BOM
- Packaging
 - 32-pin SQFN (5 x 5 mm) lead-free RoHS compliant package with MII and RMII
- Environmental
 - Commercial temperature range (0°C to +70°C)
 - Industrial temperature range (-40°C to +85°C)

**ORDER NUMBER(S):****LAN8741-EN (Tray) for 32-pin, SQFN lead-free RoHS compliant package (0°C to +70°C temp)****LAN8741i-EN (Tray) for 32-pin, SQFN lead-free RoHS compliant package (-40°C to +85°C temp)****LAN8741-EN-TR (Tape & Reel) for 32-pin, SQFN lead-free RoHS compliant package (0°C to +70°C temp)****LAN8741i-EN-TR (Tape & Reel) for 32-pin, SQFN lead-free RoHS compliant package (-40 to +85°C temp)****This product meets the halogen maximum concentration values per IEC61249-2-21****For RoHS compliance and environmental information, please visit www.smsc.com/rohs**

Please contact your SMSC sales representative for additional documentation related to this product such as application notes, anomaly sheets, and design guidelines.



General Description

The LAN8741/LAN8741i is a low-power 10BASE-T/100BASE-TX physical layer (PHY) transceiver with variable I/O voltage that is compliant with the IEEE 802.3, 802.3u, and 802.3az (Energy Efficient Ethernet) standards. Energy Efficient Ethernet (EEE) support results in significant power savings during low link utilizations.

The LAN8741/LAN8741i supports communication with an Ethernet MAC via a standard MII (IEEE 802.3u)/RMII interface. It contains a full-duplex 10-BASE-T/100BASE-TX transceiver and supports 10 Mbps (10BASE-T) and 100 Mbps (100BASE-TX) operation. The LAN8741/LAN8741i implements auto-negotiation to automatically determine the best possible speed and duplex mode of operation. HP Auto-MDIX support allows the use of direct connect or cross-over LAN cables.

The LAN8741/LAN8741i supports both IEEE 802.3-2005 compliant and vendor-specific register functions. However, no register access is required for operation. The initial configuration may be selected via the configuration pins. Register-selectable configuration options may be used to further define the functionality of the transceiver.

Per IEEE 802.3-2005 standards, all digital interface pins are tolerant to 3.6 V. The device can be configured to operate on a single 3.3 V supply utilizing an integrated 3.3 V to 1.2 V linear regulator. The linear regulator may be optionally disabled, allowing usage of a high efficiency external regulator for lower system power dissipation.

The LAN8741/LAN8741i is available in commercial (0°C to +70°C) and industrial (-40°C to +85°C) temperature range versions. A typical system application is shown in [Figure 1](#). [Figure 2](#) provides an internal block diagram of the device.

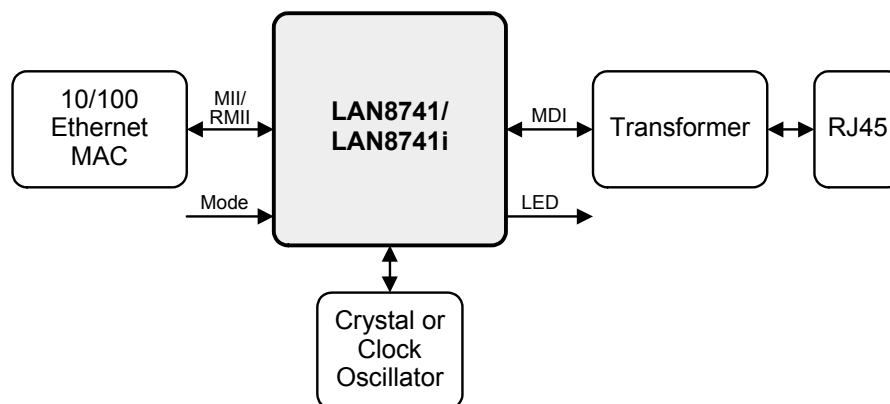

Figure 1 System Block Diagram

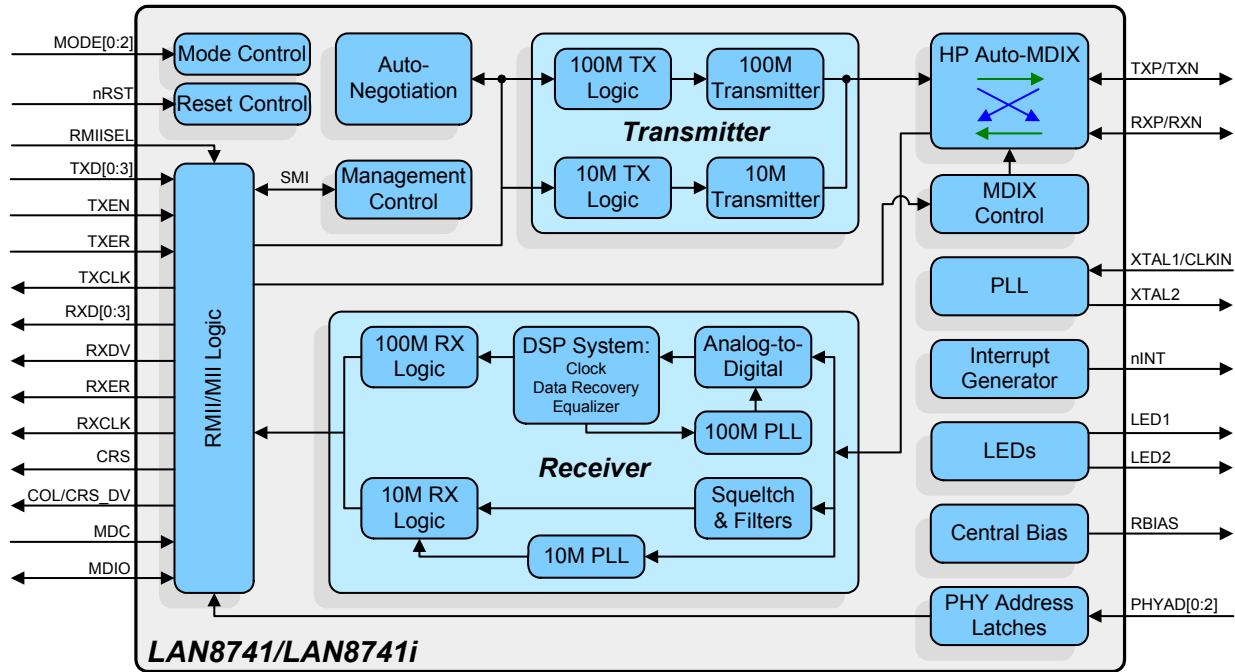

Figure 2 Architectural Overview

Package Outline

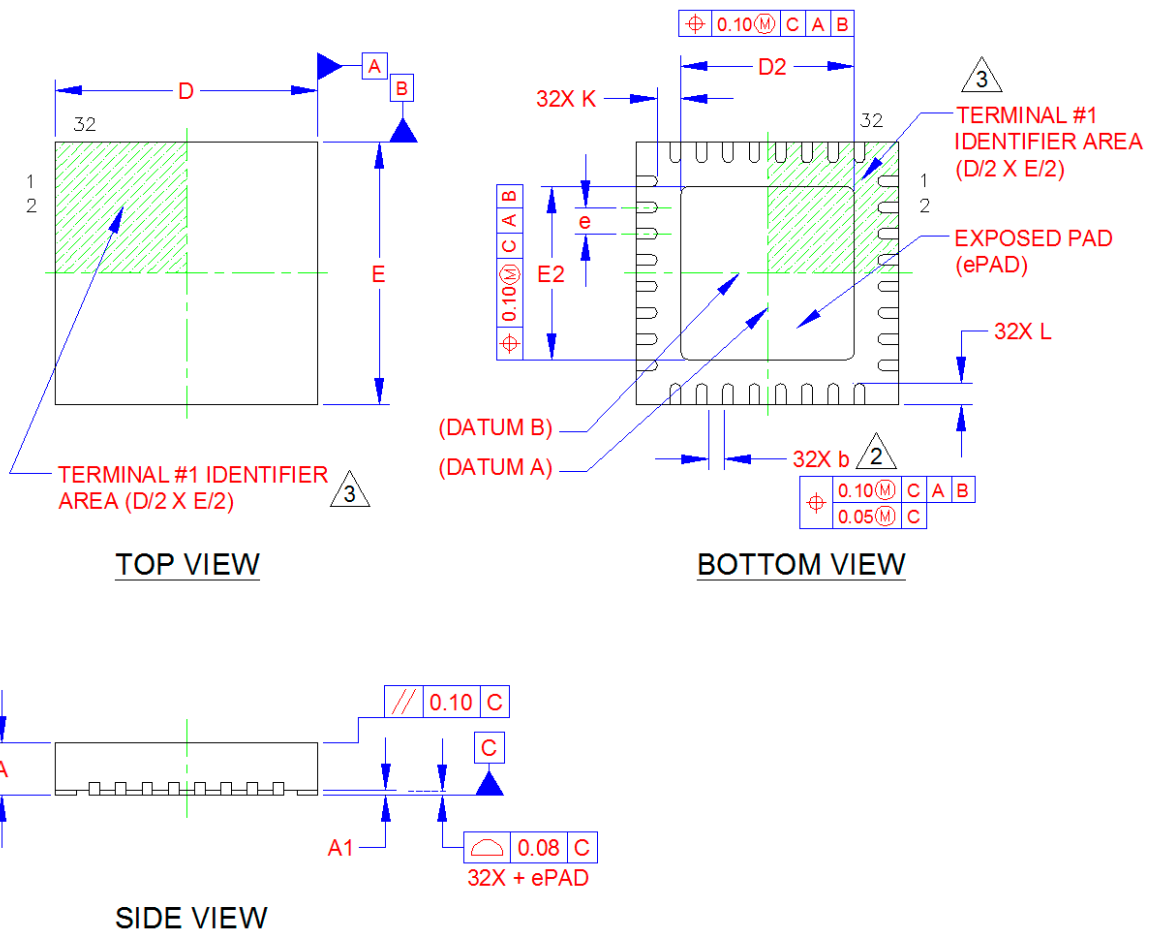

Figure 3 32-SQFN Package

Table 1 32-SQFN Dimensions

	MIN	NOMINAL	MAX	REMARKS
A	0.80	0.90	1.00	Overall Package Height
A1	0	0.02	0.05	Standoff
D/E	4.90	5.00	5.10	X/Y Body Size
D2/E2	3.20	3.30	3.40	X/Y Exposed Pad Size
L	0.35	0.40	0.45	Terminal Length
b	0.18	0.25	0.30	Terminal Width
k	0.35	0.45	-	Pin to Exposed Pad Clearance
e	0.50 BSC			Terminal Pitch

Notes:

1. All dimensions are in millimeters unless otherwise noted.
2. Dimension "b" applies to plated terminals and is measured between 0.15 and 0.30 mm from the terminal tip.
3. The pin 1 identifier may vary, but is always located within the zone indicated.

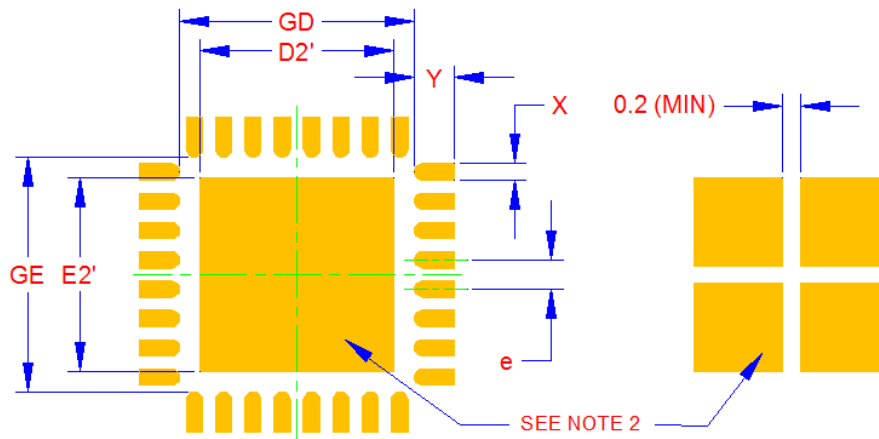

LAND PATTERN DIMENSIONS			
SYMBOL	MIN	NOM	MAX
GD/GE	4.00	-	4.10
D2'/E2'	-	3.30	3.30
X	-	0.28	0.28
Y	-	0.69	-
e	0.50		

NOTES:

1. THE USER MAY MODIFY THE PCB LAND PATTERN DESIGN AND DIMENSIONS BASED ON THEIR EXPERIENCE AND/OR PROCESS CAPABILITY
2. EXPOSED SOLDERABLE COPPER AREA OF THE CENTER PAD CAN BE EITHER SOLID OR SEGMENTED
3. MAXIMUM THERMAL AND ELECTRICAL PACKAGE PERFORMANCE IS ACHIEVED WHEN AN ARRAY OF SOLID VIAS IS INCORPORATED IN THE CENTER LAND PATTERN

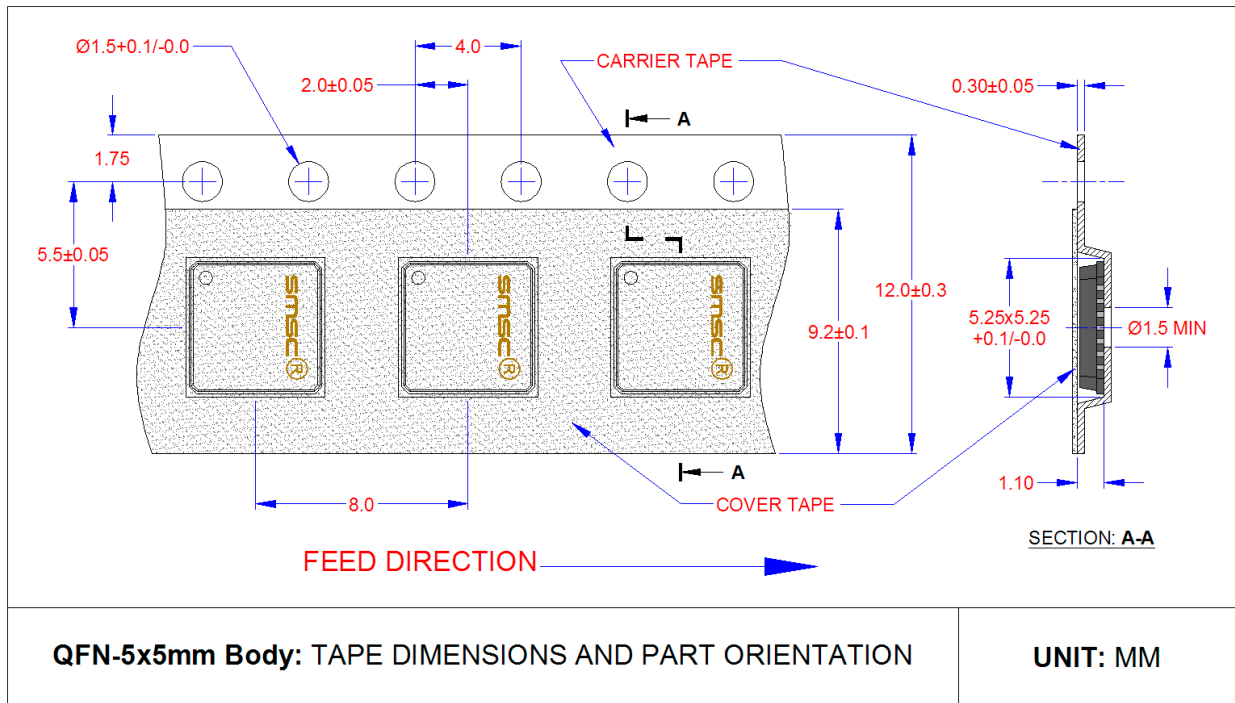
Figure 4 Recommended PCB Land Pattern

QFN-5x5mm Body: TAPE DIMENSIONS AND PART ORIENTATION
UNIT: MM
Figure 5 Taping Dimensions and Part Orientation

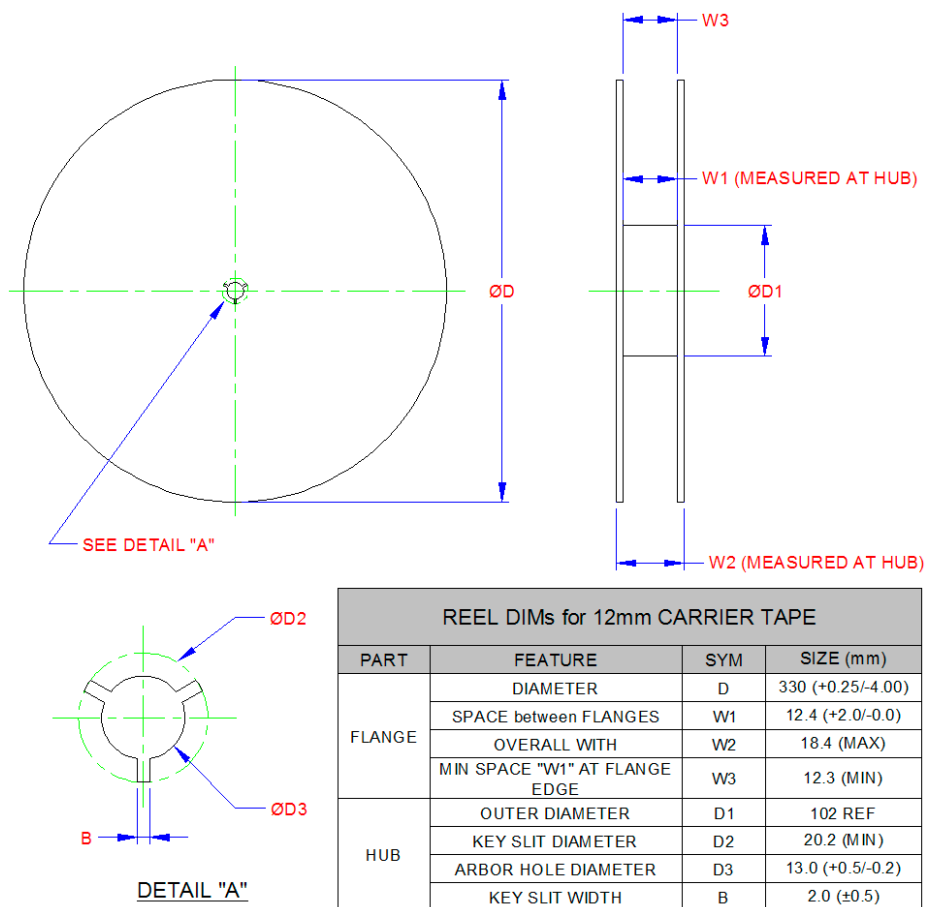

Figure 6 Reel Dimensions

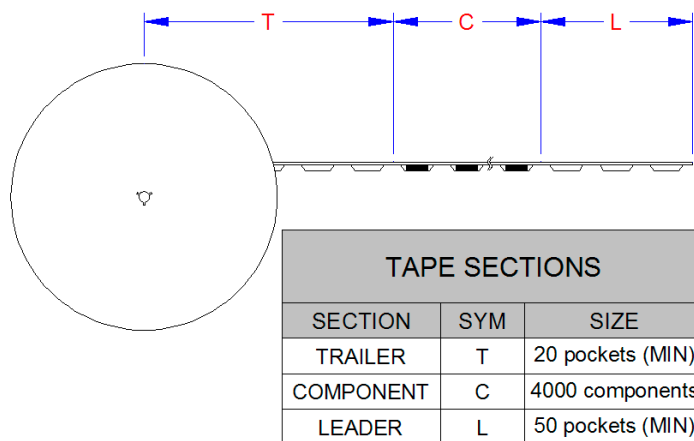

Figure 7 Tape Length and Part Quantity

Note: Standard reel size is 4,000 pieces per reel.

X-ON Electronics

Largest Supplier of Electrical and Electronic Components

Click to view similar products for [Telecom Interface Ics](#) category:

Click to view products by [Microchip](#) manufacturer:

Other Similar products are found below :

[82P2821BHG](#) [MT8888CP1](#) [MT9174AN1](#) [LC850541-E](#) [SI3010-F-FSR](#) [CH1817L](#) [M83262G13](#) [MT8870DNR1](#) [MT88E39ASR1](#)
[MT9074AL1](#) [MT9122AP1](#) [82V2082PFG8](#) [WPCS6051C.B0-900246](#) [MT9074AP1](#) [DS34S102GN+](#) [DS3150TNC1+](#) [Si3050-E1-FTR](#)
[XRT6164CD-F](#) [DS26334GN+](#) [PM4351-NGI](#) [PM5384-NGI](#) [MT88E46AS1](#) [MT8963AE1](#) [MT9076BP1](#) [LE88231DLC](#) [DS26324GNA3+](#)
[82P2521BHG](#) [PM8310A-FEI](#) [PM4351-RI](#) [DS21354LB+](#) [PEF41068FV11 S LL8T](#) [LE9632RQC](#) [LE9622RQC](#) [LE9653AQC](#) [SI3050-E1-GTR](#)
[PEF41068VV12 S LL8U](#) [LE58QL022BVC](#) [LE58QL022BVCT](#) [SI32260-C-FM1R](#) [SI32392-B-GM](#) [82P2917ABBG](#) [SI3019-F-GSR](#)
[EELXT914PC.B3 865795](#) [LE88266DLC](#) [LCP22-150B1RL](#) [W7100A-S2E-100LQFP](#) [USR5686G](#) [MT88L70AS1](#) [DS34S104GN](#)
[DS26514GN+](#)