



LC898215XA

CMOS LSI

AF(Auto Focus) Control LSI

ON Semiconductor®

<http://onsemi.com>

Overview

The LC898215 is a focus control LSI for cellphone/smartphone camera modules. It controls pre-loaded type actuators. The LSI is composed of a fast settling time circuit and a driver circuit to enable the control.

The fast settling time circuit features the high speed movement completion of the actuator.

Pre-loaded type actuators have unintentional oscillation by resonance frequency due to their structures while moving with step signal type current change, and it may interfere with the accurate focus control.

This LSI's fast settling time circuit permits optimum control of the current change. It enables high speed movement completion of the actuator so that the circuit will be an effective function for configuring high speed focus control systems.

Function

- Built-in Fast Settling Time Circuit.
- I²C Interface
 - 1.8V tolerant
- Built-in Power On Reset
- Built-in OSC
 - 40 MHz
- Built-in LDO
 - 1.5V for Logic unit
- Built-in PWM pulse generator circuit
 - PWM circuit for AF control
- 1-chip motor driver
 - Saturation drive 1 channel
 - I_O max 100mA
- Package
 - WL-CSP 6 pin
 - Pb-free, Halogen Free
- Supply voltage
 - VM (2.6 to 3.6 V)

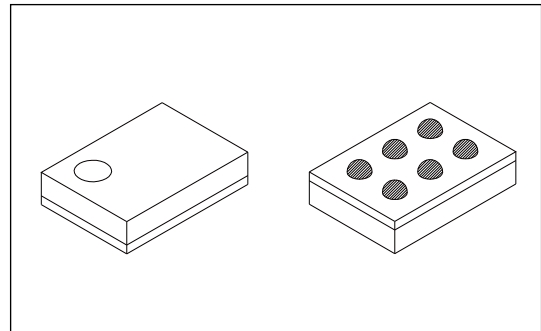

WLP6(1.29X0.80)

* I²C Bus is a trademark of Philips Corporation.

ORDERING INFORMATION

See detailed ordering and shipping information on page 4 of this data sheet.

Pin Description

■ I ² C interface			
I2CCK	B		I ² C Clock pin
I2CDT	B		I ² C Data pin
■ Driver interface			
OUT1	O		Actuator output pin
ENA/OUT2	B		LSI enable / Actuator output pin
■ Power supply pin			
VDD	P		Power supply
GND	P		GND

PIN TYPE “O” – Ensure that it is set to OPEN.

PIN TYPE “I” – OPEN is inhibited. Ensure that it is connected to the V_{DD} or V_{SS} even when it is unused.

(Please contact our company. for more information about selection of V_{DD} or V_{SS}.)

PIN TYPE “B” – If you are unsure about processing method on the pin description of pin layout table, please contact us.

Note that incorrect processing of unused pins may result in defects.

If you have any question, please feel free to contact us.

Pin Layout

Circuit Name	Number of Pins
Analog	4
Logic	2

Pin layout diagram : Top View (Ball Side Down)

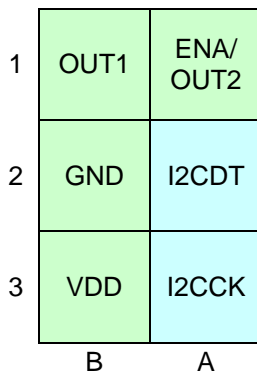

Block Diagram

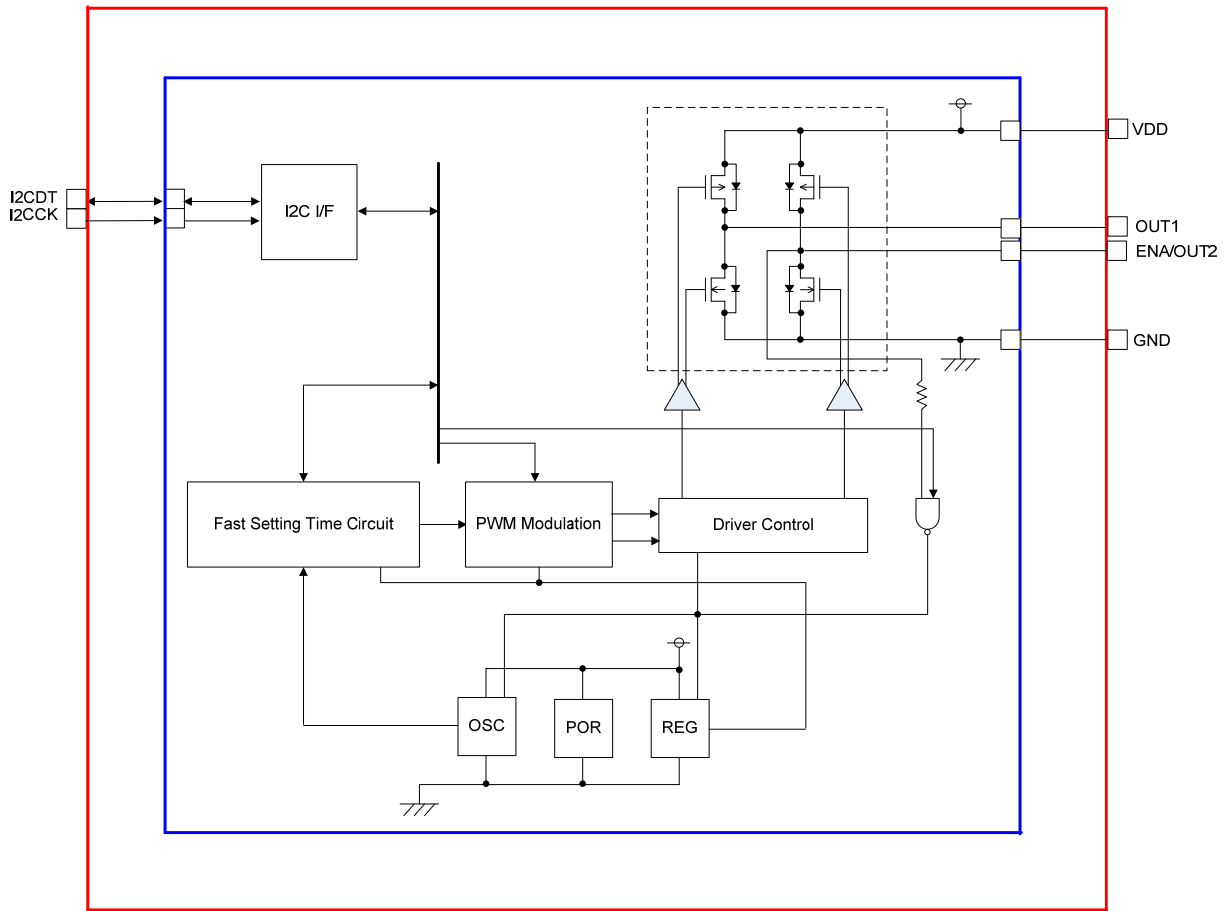

LC898215XA

PACKAGE DIMENSIONS

WLP6(1.29X0.80)

unit : mm

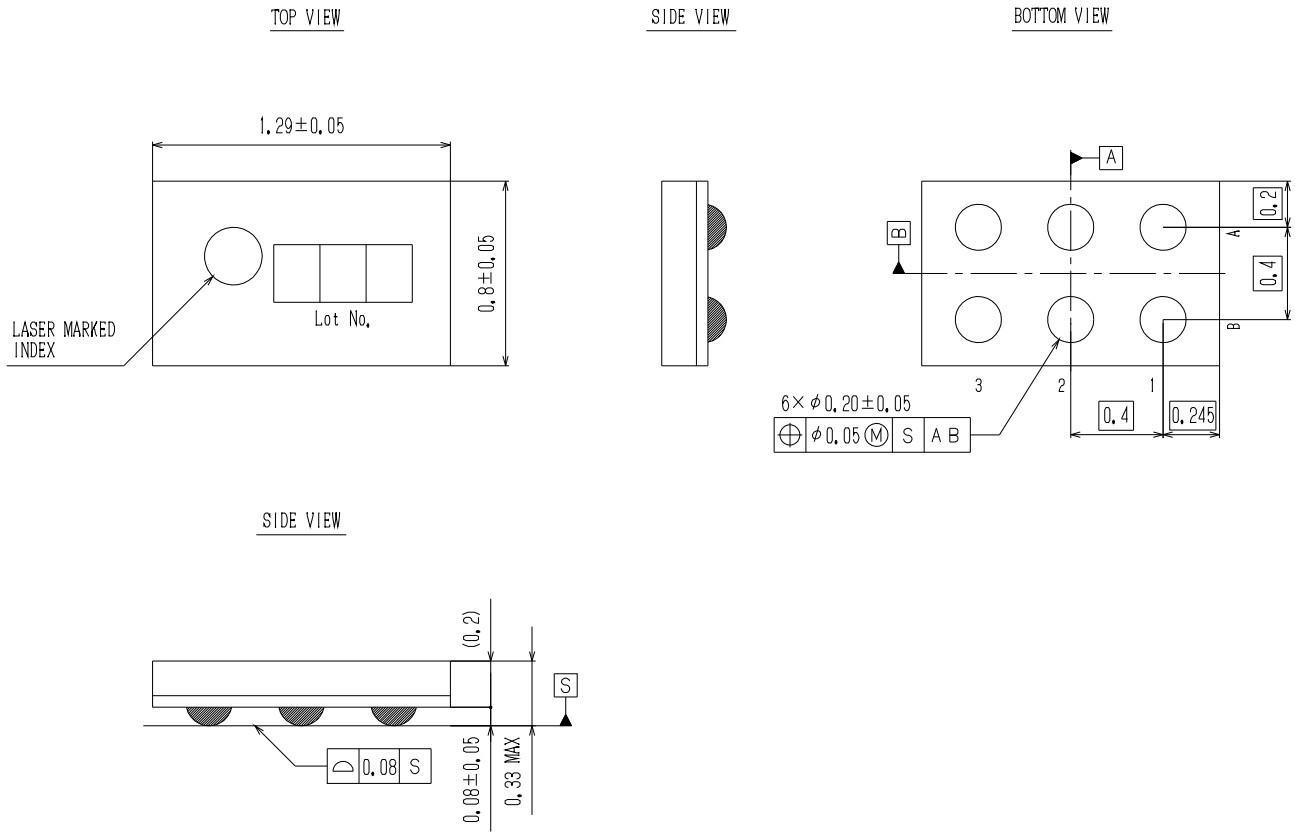

ORDERING INFORMATION

Device	Package	Shipping (Qty / Packing)
LC898215XA-MH	WLP6(1.29X0.80) (Pb-Free / Halogen Free)	5000 / Tape & Reel

ON Semiconductor and the ON logo are registered trademarks of Semiconductor Components Industries, LLC (SCILLC). SCILLC owns the rights to a number of patents, trademarks, copyrights, trade secrets, and other intellectual property. A listing of SCILLC's product/patent coverage may be accessed at www.onsemi.com/site/pdf/Patent-Marking.pdf. SCILLC reserves the right to make changes without further notice to any products herein. SCILLC makes no warranty, representation or guarantee regarding the suitability of its products for any particular purpose, nor does SCILLC assume any liability arising out of the application or use of any product or circuit, and specifically disclaims any and all liability, including without limitation special, consequential or incidental damages. "Typical" parameters which may be provided in SCILLC data sheets and/or specifications can and do vary in different applications and actual performance may vary over time. All operating parameters, including "Typicals" must be validated for each customer application by customer's technical experts. SCILLC does not convey any license under its patent rights nor the rights of others. SCILLC products are not designed, intended, or authorized for use as components in systems intended for surgical implant into the body, or other applications intended to support or sustain life, or for any other application in which the failure of the SCILLC product could create a situation where personal injury or death may occur. Should Buyer purchase or use SCILLC products for any such unintended or unauthorized application, Buyer shall indemnify and hold SCILLC and its officers, employees, subsidiaries, affiliates, and distributors harmless against all claims, costs, damages, and expenses, and reasonable attorney fees arising out of, directly or indirectly, any claim of personal injury or death associated with such unintended or unauthorized use, even if such claim alleges that SCILLC was negligent regarding the design or manufacture of the part. SCILLC is an Equal Opportunity/Affirmative Action Employer. This literature is subject to all applicable copyright laws and is not for resale in any manner.

X-ON Electronics

Largest Supplier of Electrical and Electronic Components

Click to view similar products for [Motor/Motion/Ignition Controllers & Drivers](#) category:

Click to view products by [ON Semiconductor](#) manufacturer:

Other Similar products are found below :

[LV8133JA-ZH](#) [LV8169MUTBG](#) [LV8774Q-AH](#) [LV8860PV-TLM-H](#) [MC33931EKR2](#) [FSB50250UTD](#) [FSB50550TB2](#) [FSBF15CH60BTH](#)
[FSBS10CH60T](#) [MP6507GR-P](#) [MP6508GF](#) [MSVCPM2-63-12](#) [MSVGW45-14-2](#) [MSVGW54-14-5](#) [NTE7043](#) [CAT3211MUTAG](#) [LA6245P-CL-TLM-E](#) [LA6245P-TLM-E](#) [LA6565VR-TLM-E](#) [LB11650-E](#) [LB1694N-E](#) [LB1837M-TLM-E](#) [LB1845DAZ-XE](#) [LC898111AXB-MH](#)
[LC898300XA-MH](#) [SS30-TE-L-E](#) [STK531-345A-E](#) [STK581U3A0D-E](#) [STK58AUNP0D-E](#) [STK621-068C-E](#) [STK621-140C](#) [STK621-728S-E](#)
[STK625-728-E](#) [STK672-400B-E](#) [STK672-432AN-E](#) [STK672-432BN-E](#) [STK672-440AN-E](#) [STK672-442AN-E](#) [AMIS30621AUA](#)
[FSB50550ASE](#) [26700](#) [LV8161MUTAG](#) [LV8281VR-TLM-H](#) [LV8702V-TLM-H](#) [LV8734VZ-TLM-H](#) [LV8773Z-E](#) [LV8807QA-MH](#)
[MC33932EK](#) [MCP8024T-H/MP](#) [TND027MP-AZ](#)