

APPROVAL SHEET

WF08P, WF06P

$\pm 1\%$, $\pm 5\%$ 0Ω , $1\Omega\sim 1M\Omega$

High Power Chip Resistors

Size 0805 1/4W ; 0603 1/8W

*Contents in this sheet are subject to change without prior notice.

FEATURE

1. Small size and light weight
2. High reliability and stability
3. Reduced size of final equipment
4. High precision
5. RoHS compliant and Lead free products

APPLICATION

- High accuracy dc-power supply
- Digital multi-meter
- Telecommunication
- Computer
- Automotive industry
- Medical and military equipment

DESCRIPTION

The resistors are constructed in a high grade ceramic body (aluminum oxide). Internal metal electrodes are added at each end and connected by a resistive paste that is applied to the top surface of the substrate. The composition of the paste is adjusted to give the approximate resistance required and the value is trimmed to nominated value within tolerance which controlled by laser trimming of this resistive layer.

The resistive layer is covered with a protective coat. Finally, the two external end terminations are added. For ease of soldering the outer layer of these end terminations is a Tin (lead free) alloy.

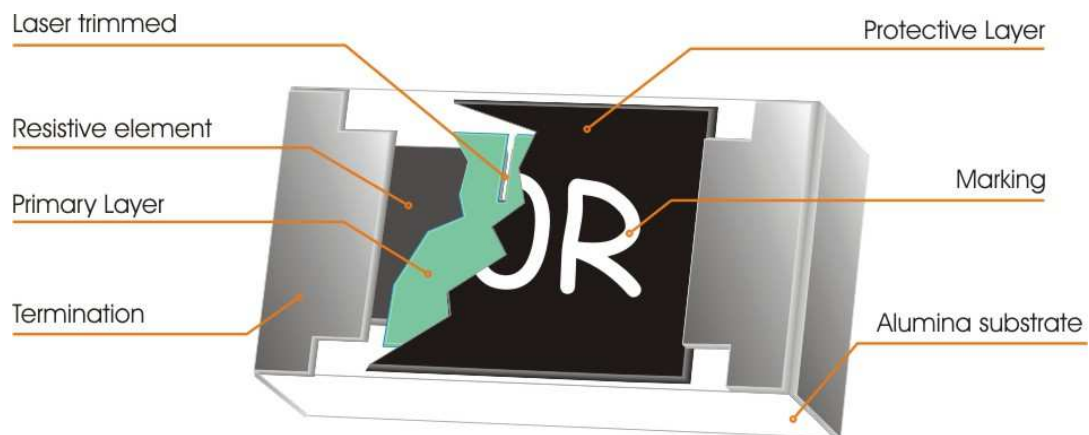

Fig 1. Construction of Chip-R

QUICK REFERENCE DATA

Item	General Specification	
Series No.	WF08P	WF06P
Size code	0805 (2012)	0603(1608)
Resistance Tolerance	±1%, ±5%	
Resistance Range	0Ω, 1Ω~ 1MΩ (E96+E24 series)	
TCR (ppm/°C) 20°C ~ +155°C 1Ω ~ 1MΩ	≤ ± 100 ppm/°C	
TCR (ppm/°C) 20°C ~ - 55°C 10Ω ~ 1MΩ	≤ ± 100 ppm/°C	
1Ω ~ 10Ω	≤ ± 150 ppm/°C	
Max. dissipation at T _{amb} =70°C	1/4 W	1/8W
Max. Operation Voltage (DC or RMS)	150V	50V
Max. Overload Voltage (DC or RMS)	300V	100V
Climatic category (IEC 60068)	55/155/56	
Basic specification	JIS C 5201-1:1998 / IEC 60068-2-58:2004	

Note :

1. This is the maximum voltage that may be continuously supplied to the resistor element, see "IEC publication 60115-8"
2. Max. Operation Voltage : So called RCWV (Rated Continuous Working Voltage) is determined by

$$RCWV = \sqrt{\text{Rated Power} \times \text{Resistance Value}}$$
or Max. RCWV listed above, whichever is lower.
3. 0Ω maximum resistance R_{max} ≤ 15mΩ and rated current (0805) ≤ 4Amp; (0603) ≤ 2Amp

DIMENSIONS(unit : mm)

Part No	WF08P	WF06P
L	2.00 ± 0.10	1.60 ± 0.10
W	1.25 ± 0.10	0.80 ± 0.10
T	0.50 ± 0.15	0.45 ± 0.15
Tb	0.40 ± 0.20	0.30 ± 0.15
Tt	0.40 ± 0.20	0.30 ± 0.10

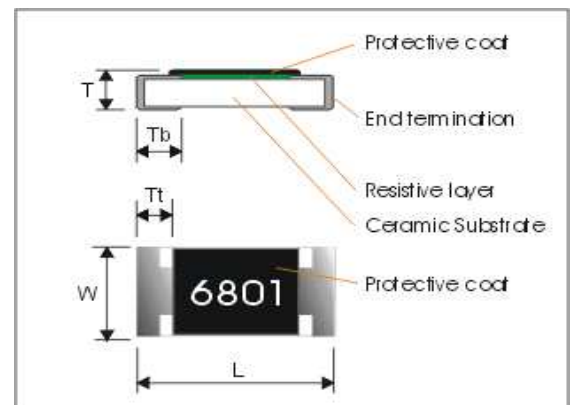
**MARKING**

Each resistor is marked with a three-digit (WF06P ±1%; ±5%; WF08P ±5%) or four-digit (WF08P ±1%) code on the protective coating to designate the nominal resistance value.

Example:

01Y = 1Ω (0603 ±1%); 103=10kΩ(0603 ±5%)
 1002 = 10kΩ (0805 ±1%); 102=1kΩ(0805 ±5%)

FUNCTIONAL DESCRIPTION

Product characterization

Standard values of nominal resistance are taken from the E96&E24 series for resistors with a tolerance of $\pm 1\%$, $\pm 5\%$. The values of the E96/E24 series are in accordance with "IEC publication 60063".

Derating

The power that the resistor can dissipate depends on the operating temperature; see Fig.2

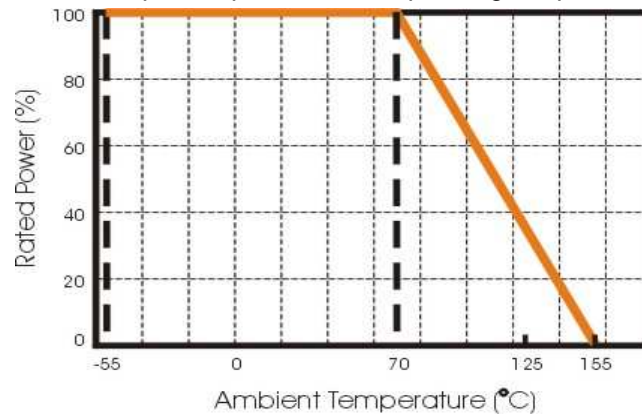

Fig.2 Maximum dissipation in percentage of rated power
As a function of the ambient temperature

MOUNTING

Due to their rectangular shapes and small tolerances, Surface Mountable Resistors are suitable for handling by automatic placement systems.

Chip placement can be on ceramic substrates and printed-circuit boards (PCBs).

Electrical connection to the circuit is by individual soldering condition.

The end terminations guarantee a reliable contact.

SOLDERING CONDITION

The robust construction of chip resistors allows them to be completely immersed in a solder bath of 260°C for 10 seconds. Therefore, it is possible to mount Surface Mount Resistors on one side of a PCB and other discrete components on the reverse (mixed PCBs).

Surface Mount Resistors are tested for solderability at 235°C during 2 seconds. The test condition for no leaching is 260°C for 30 seconds. Typical examples of soldering processes that provide reliable joints without any damage are given in Fig 3.

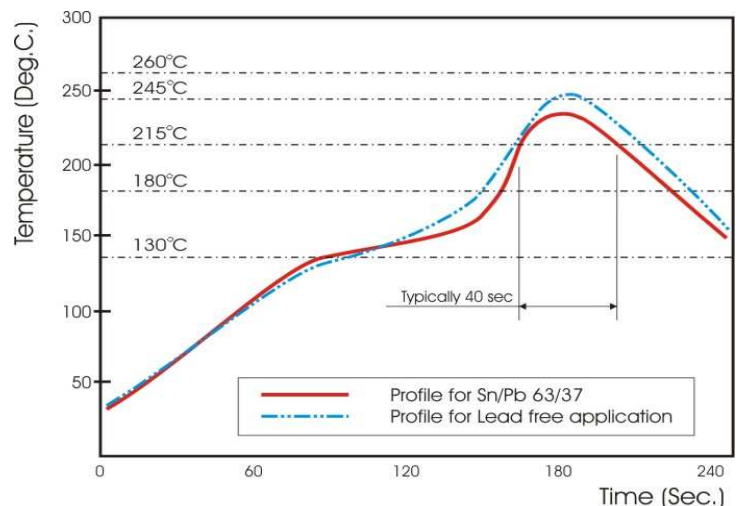

Fig 3. Infrared soldering profile for Chip Resistors

CATALOGUE NUMBERS

The resistors have a catalogue number starting with .

WF08	P	1002	F	T	L
Size code WF08: 0805 WF06: 0603	Type code P :Power 0805 size=0.25W 0603 size=0.125W	Resistance code 5% E24: 2 significant digits followed by No. of zeros e.g.: 3ohm =3R0 10ohm =100 56Kohm =563 1% E24+E96: 3 significant digits followed by No. of zeros 100Ω =1000 37.4KΩ =3742	Tolerance J : ±5% F : ±1% P : Jumper	Packaging code T : 7" Reeled taping paper taping 5Kpcs/reel.	Termination code L = Sn base (lead free)

- Reeled tape packaging : 8mm width paper taping 5000pcs per 7" reel.

TEST AND REQUIREMENTS

Basic specification : JIS C 5201-1 : 1998

TEST	PROCEDURE	REQUIREMENT
Clause 4.8 Temperature Coefficient of Resistance (TCR)	Natural resistance change per change in degree centigrade. $\frac{R_2 - R_1}{R_1(t_2 - t_1)} \times 10^6 \text{ (ppm/}^\circ\text{C)}$ R ₁ : Resistance at reference temperature R ₂ : Resistance at test temperature t ₁ : 20°C+5°C-1°C.	Refer to quick reference data for T.C.R specification
Clause 4.13 Short time overload	5.0x Rated power or Max. Overload Voltage for 5 sec. Measure resistance after 30 minutes.	$\Delta R/R \text{ max. J: } \leq \pm(2\%+0.1\Omega)$ $F: \leq \pm(1\%+0.05\Omega)$
Clause 4.18 Resistance to soldering heat(R.S.H)	Un-mounted chips completely immersed for 10±1second in a SAC solder bath at 260°C±5°C.	No visible damage $\Delta R/R \text{ max. J: } \leq \pm(1\%+0.1\Omega)$ $F: \leq \pm(0.5\%+0.05\Omega)$
Clause 4.17 Solderability	Un-mounted chips completely immersed for 2±0.5 second in a SAC solder bath at 235°C±5°C.	Good tinning (>95% covered) No visible damage
Clause 4.19 Temperature cycling	1. 30 minutes at -55°C±3°C, 2. 2~3 minutes at 20°C+5°C-1°C, 3. 30 minutes at +155°±3°C, 4. 2~3 minutes at 20°C+5°C-1°C, Total 5 continuous cycles.	No visible damage $\Delta R/R \text{ max. J } \leq \pm(1\%+0.1\Omega)$ $F \leq \pm(0.5\%+0.05\Omega)$
Clause 4.25 Load life (endurance)	1000 +48/-0 hours, loaded with RCWV or Vmax in chamber controller 70±2°C, 1.5 hours on and 0.5 hours off.	No visible damage $\Delta R/R \text{ max. J } \leq \pm(3\%+0.1\Omega)$ $F \leq \pm(1\%+0.05\Omega)$
Clause 4.24 Load life in Humidity	1000 +48/-0 hours, loaded with RCWV or Vmax in humidity chamber controller at 40°C±2°C and 90~95% relative humidity, 1.5hours on and 0.5 hours off.	No visible damage $\Delta R/R \text{ max. J } \leq \pm(3\%+0.1\Omega)$ $F \leq \pm(1\%+0.05\Omega)$
Clause 4.33 Bending strength	Resistors mounted on a 90mm glass epoxy resin PCB(FR4); bending : 3 mm, once for 10 seconds.	No visible damage $\Delta R/R \text{ max. J } \leq \pm(1\%+0.1\Omega)$ $F \leq \pm(0.5\%+0.05\Omega)$
Clause 4.32 Adhesion	Pressurizing force: 5N, Test time: 10±1sec.	No remarkable damage or removal of the terminations
Clause 4.6 Insulation Resistance	Apply the maximum overload voltage (DC) for 1minute.	$R \geq 10G\Omega$
Clause 4.7 Dielectric Withstand Voltage	Apply the maximum overload voltage (AC) for 1 minute.	No breakdown or flashover

PACKAGING

Paper Tape specifications (unit :mm)

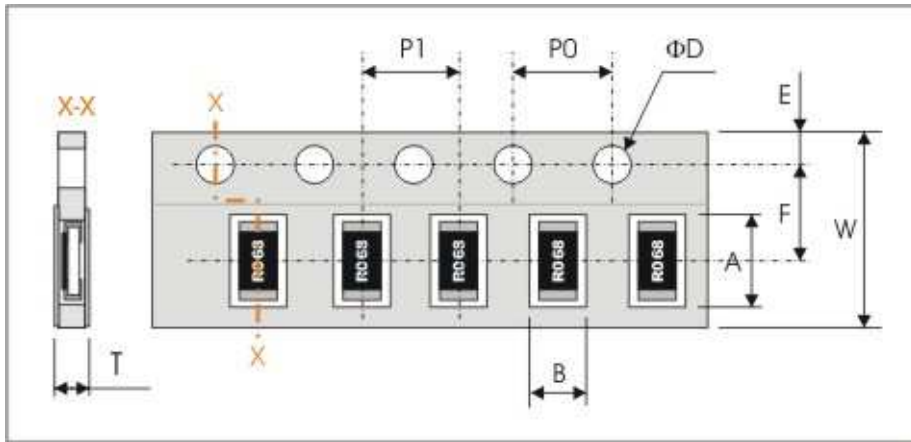

Series No.	A	B	W	F	E
WF06P	1.90±0.20	1.10±0.20	8.00±0.30	3.50±0.20	1.75±0.10
WF08P	2.40±0.20	1.65±0.20			

Series No.	P1	P0	ΦD	T
WF06P	4.00±0.10	4.00±0.10	Φ1.50 ^{+0.1} _{-0.0}	0.65±0.05
WF08P				Max. 1.0

Reel dimensions

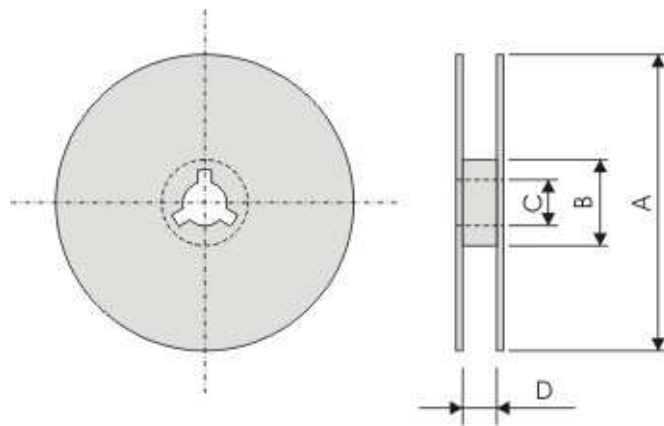

Symbol	A	B	C	D
(unit : mm)	Φ178.0±2.0	Φ60.0±1.0	13.0±0.2	9.0±0.5

X-ON Electronics

Largest Supplier of Electrical and Electronic Components

Click to view similar products for [Thick Film Resistors - SMD category](#):

Click to view products by [Walsin manufacturer](#):

Other Similar products are found below :

[CRCW04028R20JNEE](#) [CRCW06036K80FKEE](#) [CRG1206F1K58](#) [CRL0603-FW-R700ELF](#) [M55342K06B6E19RWL](#) [RC1005F1072CS](#)
[RC1005F471CS](#) [RC1005F4751CS](#) [RCP0603W100RGED](#) [ERJ-1GMF1R00C](#) [ERJ-1GMF1R20C](#) [ERJ-1GMF2R55C](#) [ERJ-1GMF8R66C](#)
[25121WF1003T4E](#) [25.501.3653.0](#) [290-1.0M-RC](#) [292-1.0M-RC](#) [292-2.2K-RC](#) [292-4.7K-RC](#) [25121WF4700T4E](#) [292-470K-RC](#) [302-1.0M-](#)
[RC](#) [CPG1206F10KC](#) [CRCW02011R00FXED](#) [CRCW060315K0FKEE](#) [CRCW060320K5FKEE](#) [CRG0201F10K](#) [RCP2512B100RGWB](#)
[RCWP12061K00FKS2](#) [3520510RJT](#) [352075KJT](#) [RMC16-102JT](#) [RMC1JPTE](#) [TR0603MR-075K1L](#) [5-2176094-4](#) [35202K7JT](#)
[WF06Q1000FTL](#) [ERJ-S14J4R7U](#) [CHP2512L4R30GNT](#) [WR12X1621FTL](#) [RCWP11001K00FKS3](#) [LRC-LRF3W-01-R050-FTR1800](#) [9-](#)
[2176088-6](#) [NRC06F1002TR20F](#) [CRCW02013M30FNED](#) [CRCW060343K0FKEE](#) [WR04X5360FTL](#) [RCA060345K3FKEA](#)
[LTR100JZPF33R0](#) [5-2176091-5](#)