

**CONNECTOR
DESIGNATORS**

**A-F-H-L
ROTATABLE
COUPLING**

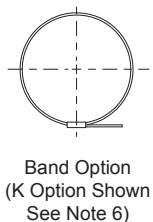

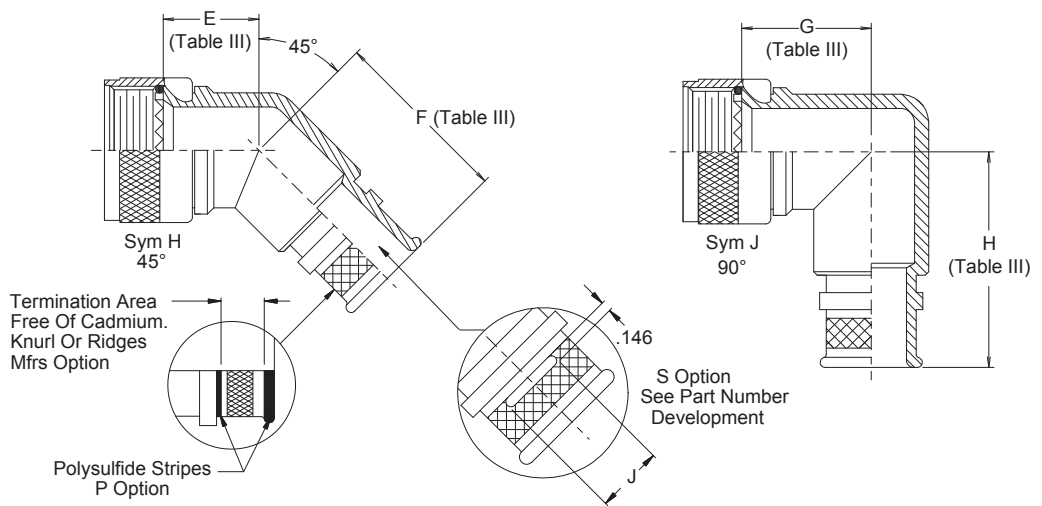
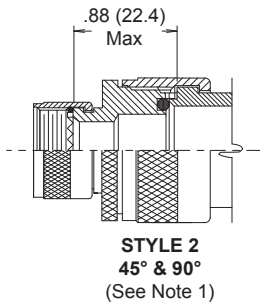
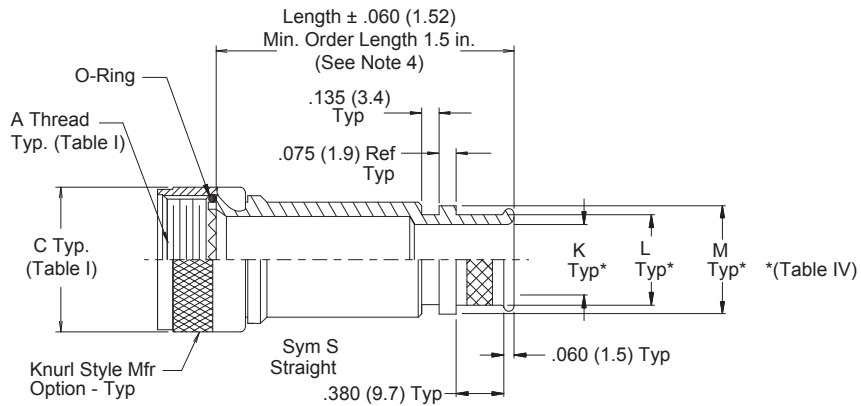
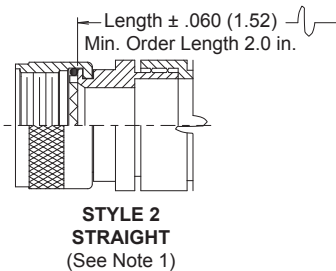
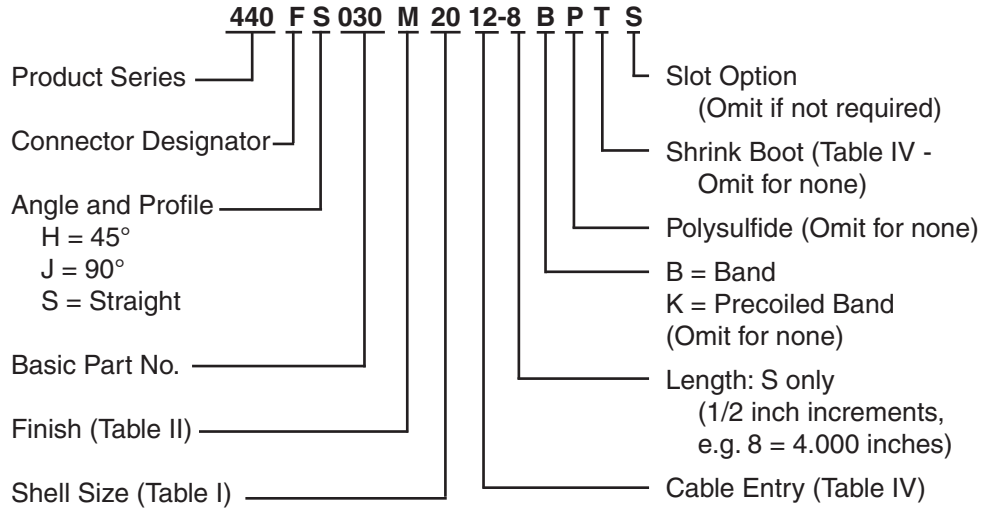

Reference Information Standard Materials and Finishes

TABLE II - STANDARD FINISHES

| GLENAIR SYMBOL | M85049 SYMBOL REFERENCE ONLY | FINISH | SPECIFICATION(S) |
|----------------|------------------------------|--|---|
| A | | Cadmium Plate, Bright | AMS-QQ-P-416, Type I, Class 2 |
| B | | Cadmium Plate, Olive Drab | AMS-QQ-P-416, Type II, Class 3 |
| C* | A | Anodize, Black | AMS-A-8625, Type II, Class 2 |
| G* | | Hard Coat, Anodic | AMS-A-8625, Type III, Class 1 |
| J | | Iridite, Gold Over Cadmium Plate Over Electroless Nickel | MIL-C-5541, Class 3 AMS-QQ-P-416, Type II, Class 3 over AMS-C-26074, Class 4, Grade B |
| LF | | Cadmium Plate, Bright Over Electroless Nickel | 1000 Hour Corrosion Resistance |
| M | N | Electroless Nickel | AMS-C-26074, Class 4, Grade B |
| N | | Cadmium Plate, Olive Drab Over Electroless Nickel | AMS-QQ-P-416, Type II, Class 3 over Electroless Nickel AMS-C-26074 |
| NC | | Zinc Cobalt, Dark Olive Drab | 96 Hour Corrosion Resistance |
| NF | W | Cadmium Plate, Olive Drab Over Electroless Nickel | 1000 Hour Corrosion Resistance |
| T | | Cadmium Plate, Bright Over Electroless Nickel | AMS-QQ-P-416, Type I, Class 3 ASTMB 733-90, SC2, Type I, Class 5, MIL-C-26074*** |
| U | | Cadmium Plate, Black | AMS-QQ-P-416, Type II, Class 3 |
| ZU** | | Cadmium Plate, Black | AMS-QQ-P-416, Type II, Class 3 |
| ZN | | Zinc-Nickel Alloy, Olive Drab | ASTMB 841-91, Over Electroless Nickel 1000 Hour Salt Spray |

* Anodize finish; not suitable for EMI Shielding or grounding applications.
** Applicable to corrosion resisting steel backshells and accessories. Consult factory for other available finishes.

The following standard materials are used for the majority of Glenair backshells and connector accessories. However, backshell components are not limited to those items listed, but are representative of the elements used in Glenair's general accessory products. Contact Glenair for applicable specifications on items not listed below.

STANDARD MATERIALS - BACKSHELLS AND ACCESSORIES

| COMPONENT | MATERIAL | SPECIFICATION |
|--|------------------------------|---------------------------------------|
| Machined components: such as backshell bodies, fabricated elbows, protective covers, rotatable couplers, dummy stowage receptacles, lock nuts, G-spring support rings, EMI ground rings, grommet followers, etc. | Aluminum | AMS-QQ-A-200 ASTMB221, 209 |
| Die cast components: such as angular backshells, strain relief backshells, strain relief bodies, strain relief saddles, special EMI ground rings, etc. | Aluminum | QQ-A-591 ASTMB85, 26 |
| Backshells or strain reliefs: available in optional corrosion resisting steel; and hardware: such as screws, washers, rivets, wire rope, sash chain, band straps, etc. | Corrosion Resisting Steel | ASTMA582 (300 Series) AMS-QQ-S-763 |
| Elastomeric seals: such as O-rings, cable jacket seals, grommets, etc. | Silicone | ZZ-R-765, MIL-R-25988 |
| Anti-friction and thrust washers | Teflon | TFE |
| Anti-rotation device | Corrosion Resistant Material | N/A |

BODY STRAP

Glenair offers an optional stainless steel body strap for attaching protective covers as illustrated. To specify body strap, add suffix letter C to the end of the part number. For example 360AS001M1610M6C.

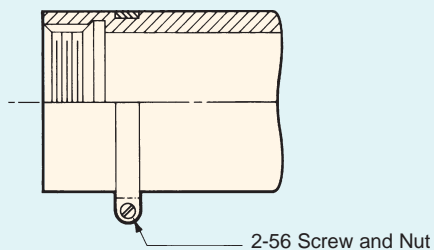

NOTES

On all length callouts, tolerance is $\pm .060$ unless otherwise specified.

Unless otherwise specified, the following other dimensional tolerances will apply:

- .xx = $\pm .03$ (0.8)
- .xxx = $\pm .015$ (0.4)
- Lengths = $\pm .060$ (1.52)
- Angles = $\pm 5^\circ$

Metric dimensions (mm) are indicated in parentheses

NOTE: For your convenience these tables have been reproduced inside the back cover fold-out.

Glenair Backshell and Accessory Material and Finish Options

Backshell and accessory base materials, plating options, specifications and codes

| Code | Material | Finish | Finish Specification |
|------------|-----------------|----------------------------|---|
| A | Aluminum | Cadmium, No Chromate | SAE-AMS-QQ-P-416 Type I Class 3 |
| AB | Marine Bronze | Unplated | |
| AL | Aluminum | AlumiPlate, Clear Chromate | MIL-DTL-83488, Class 2, Type II over electroless nickel |
| B | Aluminum | Cadmium, Olive Drab | SAE-AMS-QQ-P-416 Type II Class 3 |
| C | Aluminum | Anodize, Black | AMS-A-8625 Type II Class 2 |
| E | Aluminum | Chem Film | MIL-DTL-5541 Type 1 Class 3 |
| G | Aluminum | Anodize, Hardcoat | AMS-A-8625 Type III, Class 1, .001" thick |
| J | Aluminum | Cadmium, Gold | SAE-AMS-QQ-P-416 Type II, Class 2 over electroless nickel |
| JF | Aluminum | Cadmium, Gold | SAE-AMS-QQ-P-416 Type II, Class 2 over electroless nickel |
| LF | Aluminum | Cadmium, Clear | SAE-AMS-QQ-P-416 Type II Class 2 over electroless nickel |
| M | Aluminum | Electroless Nickel | AMS-C-26074 Class 4 Grade B; ASTM-B-733, SC 2, Type IV |
| MT | Aluminum | Nickel-PTFE | GMF-002 Type II Class 1 |
| N | Aluminum | Cadmium, Olive Drab | SAE-AMS-QQ-P-416 Type II Class 3 over electroless nickel |
| NC | Aluminum | Zinc-Cobalt, Olive Drab | ASTM B 840 Grade 6 Type D over electroless nickel |
| NF | Aluminum | Cadmium, Olive Drab | SAE-AMS-QQ-P-416 Type II Class 2 over electroless nickel |
| P | Stainless Steel | Electrodeposited Nickel | SAE-AMS-QQ-N-290 Class 1 Grade F |
| T | Aluminum | Cadmium, No Chromate | SAE-AMS-QQ-P-416 Type I Class 3 |
| TP2 | Titanium | Electrodeposited Nickel | SAE-AMS-QQ-N-290 Class 1 Grade F |
| U | Aluminum | Cadmium, Black | SAE-AMS-QQ-P-416 Type I Class 3 |
| UC | Aluminum | Zinc-Cobalt, Black | ASTM B 840 Grade 6 Type D over electroless nickel |
| UCR | Aluminum | Zinc-Cobalt, Black | ASTM B 840 Grade 6 Type D over electroless nickel |
| UF | Aluminum | Cadmium, Black | SAE-AMS-QQ-P-416 Type II Class 2 over electroless nickel |
| XAL | Composite | AlumiPlate | MIL-DTL-86448, Class 2, Type II over electroless nickel |
| XB | Composite | Unplated Black | |
| XM | Composite | Electroless Nickel | AMS-C-26074 |
| XMT | Composite | Nickel-PTFE | GMS-002 Class 2 Type II |
| XO | Composite | Unplated Light Brown | |
| XW | Composite | Cadmium, Olive Drab | SAE-AMS-QQ-P-416 Type II Class 3 over electroless nickel |
| XZN | Composite | Zinc-Nickel, Black | ASTM B841 Grade 5 over electroless nickel |
| Z1 | Stainless Steel | Passivate | SAE-AMS-SAE-AMS-QQ-P-35 Type VI |
| Z2 | Aluminum | Gold | MIL-DTL-45204 Class 1 over electroless nickel |
| ZC | Stainless Steel | Zinc-Cobalt, Black | ASTM-B840, Grade 6 |
| ZCR | Stainless Steel | Zinc-Cobalt, Black | ASTM-B840, Grade 6 |
| ZL | Stainless Steel | Electrodeposited Nickel | SAE-AMS-QQ-N-290 Class 1 Grade F |
| ZM | Stainless Steel | Electroless Nickel | AMS-C-26074 Class 1 Grade A |
| ZMT | Stainless Steel | Nickel-PTFE | GMF-002 Type II Class 3 |
| ZN | Aluminum | Zinc-Nickel, Olive Drab | ASTM B841 Grade 5 over electroless nickel |
| ZNU | Aluminum | Zinc-Nickel, Black | ASTM B841 Grade 5 over electroless nickel |
| ZR | Aluminum | Zinc-Nickel, Black | ASTM B841 Grade 5 over electroless nickel |
| ZU | Stainless Steel | Cadmium, Black | SAE-AMS-QQ-P-416 Type II Class 3 |
| ZW | Stainless Steel | Cadmium, Olive Drab | SAE-AMS-QQ-P-416 Type II Class 2 over electroless nickel |

X-ON Electronics

Largest Supplier of Electrical and Electronic Components

Click to view similar products for [Standard Circular Connector](#) category:

Click to view products by [Glenair](#) manufacturer:

Other Similar products are found below :

[C015 10F006 001 1](#) [5M2530B10P](#) [600247N007](#) [600259N006](#) [600273N007](#) [600432N009](#) [6280-2PG-519](#) [6280-3PG-311](#) [6280-3SG-311](#)
[6280-7SG-3DC](#) [6280-7SG-522](#) [6282-5PG-311](#) [6282-6PG-519](#) [6282-8SG-311](#) [6283-11](#) [6283-15](#) [6290](#) [6293](#) [6382-2PG-311](#) [6382-2PG-3DC](#)
[6382-2SG-321](#) [6382-2SG-3DC](#) [6382-4SG-516](#) [67-03E20-37P](#) [681-PMG](#) [CXS3102A14S2P](#) [CXS3102A181S](#) [CXS3106A14S6S](#)
[D38999/20FC8SA L/C](#) [MB12P-1](#) [MB12R-6](#) [7251-2PG-300](#) [7251-2SG-300](#) [7251-4PG-300](#) [7251-4SG-300](#) [7251-5PG-300](#) [7251-5SG-300](#)
[7251-6SG-300](#) [7251-7PG-300](#) [7251-8PG-300](#) [7271-6SG-300](#) [7282-3PG-300-CH3](#) [73000005663](#) [75-190011-03P](#) [75-190216-08S](#) [75-190218-](#)
[10P](#) [75-214636-52P](#) [75-474118-10P](#) [75-474211-03P](#) [75-474218-19S](#)