

## Safety Switches Table of Contents

# Safety Switches

### Selection Criteria

Selection Flowchart.....	3-2
Selection Tips.....	3-3
Technology Overview.....	3-4

### Interlock Overview

Versatility.....	3-6
Accessories for Tongue and Guard Locking Switches.....	3-7
Product Selection.....	3-8
Safety Switches and Connectors.....	3-9

### Tongue Switches

Elf™.....	3-10
Cadet™ 3.....	3-14
Trojan™ T15.....	3-18
Trojan™ 5 & 6.....	3-22
MT-GD2.....	3-28

### Guard Locking Switches

Overview.....	3-33
440G-MT.....	3-36
TLS-GD2.....	3-40
Atlas™ 5.....	3-46
Accessories for Interlock and Guard Locking Switches.....	3-50

### Non-Contact Switches

SensaGuard™.....	3-56
Ferrogard™ 1, 2, 20 & 21.....	3-70
Ferrogard™ 3, 4 & 5.....	3-74
Ferrogard™ 6, 9, 10, 13 & 14.....	3-76
Ferrogard™ GD2.....	3-80
Ferrogard™ GS1 & GS2.....	3-84
Sipha™ Sensors.....	3-86

### Hinge Switches

Sprite™.....	3-90
Ensign™ 3.....	3-94
Rotacam™.....	3-98

### Prosafes Trapped Key

Overview.....	3-102
Rotary Switch.....	3-108
Solenoid Release Unit.....	3-112
Electronic Timed-Delay Unit.....	3-114
Stopped Motion Units.....	3-116
Exchange Units.....	3-118
Bolt Interlocks.....	3-120
Access/Chains Interlocks.....	3-122
Slamlock.....	3-124
Miniature Valve Interlock.....	3-130
Switchgear Adaptors.....	3-131
Accessories.....	3-132

### Safety Limit Switches

#### IEC Style Switches

Overview.....	3-133
22 mm Plastic.....	3-134
30 mm Metal.....	3-139
15 mm Plastic.....	3-143

#### NEMA Style Switches

802T Direct Opening Action.....	3-145
---------------------------------	-------

3-Interlock  
Switches

## Safety Switches Selection Flowchart

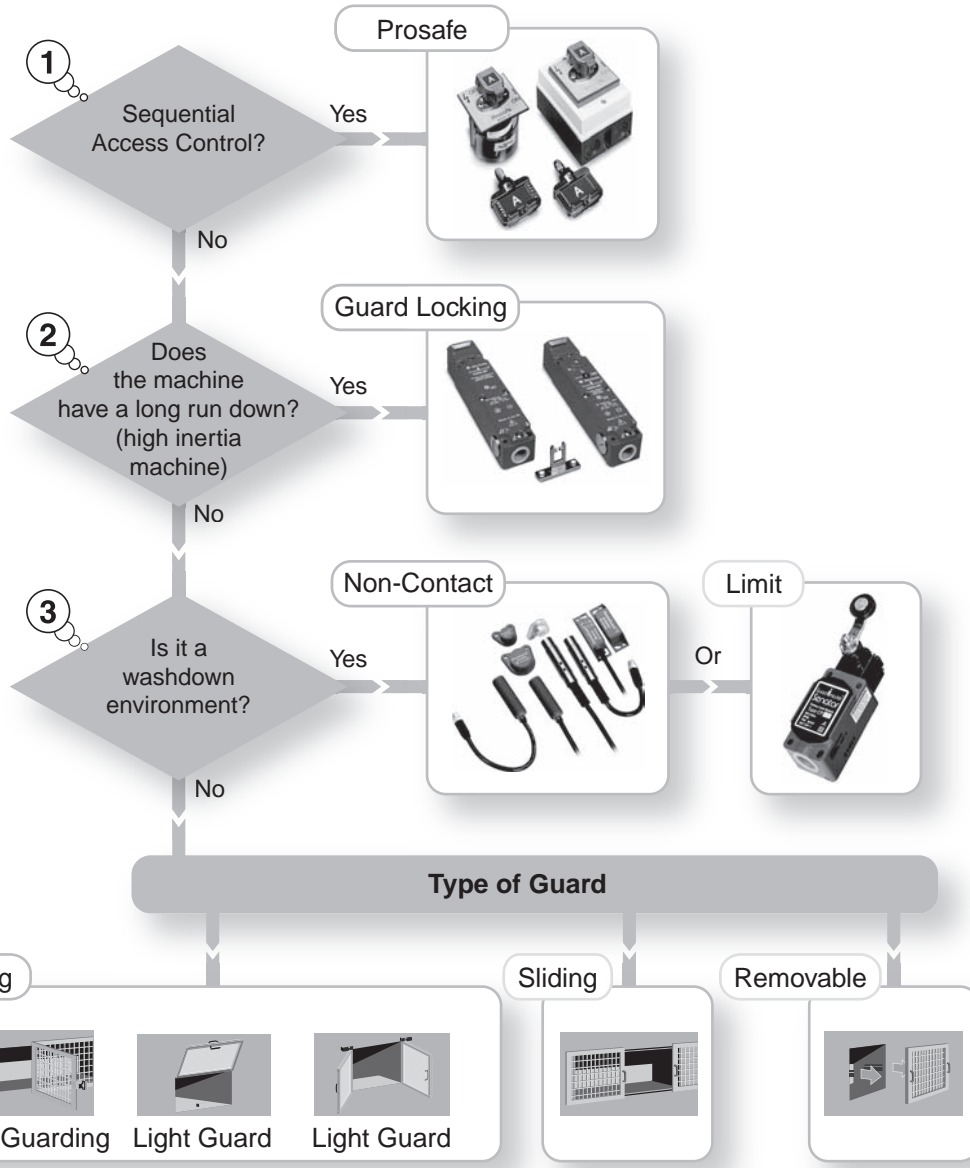

3-Interlock  
Switches

Recommended Product Type	Swinging	Sliding	Removable
Tongue	✓	✓	✓
Guard Locking	✓		✓
Non-Contact	✓	✓	✓
Hinge	✓		✓

## 1 Sequential Access Control

A Sequential Access Control system requires that a predetermined sequence of events takes place or that hazards have been reduced before operators can become exposed to them. Prosafe trapped key interlocks are a mechanical system based on coded keys that achieves this via the premise that no single key can be used in two places at once. And because of their mechanical operation, Prosafe trapped key interlocks are widely used in applications where the location of plant, environment or explosive atmospheres make the use of electrical interlock systems unsuitable or expensive to install.

## 2 High Inertia Machine (Long Run Down Time)

A High Inertia Machine is one on which hazardous motion does not cease immediately when the safety measures are engaged. As a result, there is a possibility that an operator can reach the hazard while it is “running down” and is still dangerous. *Interlock switches with guard locking reduce the risk that the guard opens during hazardous machine motion.*

Alternative measures:

- Install a braking device which stops the machine motion in a shorter time span.
- Increase the distance between the guard door and the hazard such that the operator cannot physically reach the hazard before it has stopped.

## 3 Washdown Environments

In many applications, primarily those in the pharmaceutical and food/beverage industries, frequent washdown of the machinery with water and/or cleaning fluids is common. Therefore, it is important to select a safety switch with the appropriate environmental protection as indicated by the product's enclosure (Ingress Protection or IP) rating. Non-contact switches have no “traps” where debris can accumulate and are available in fully sealed versions (IP67/IP68/IP69K), making them ideal for washdown applications.

For details on enclosure ratings, refer to the General section of this catalog (page G-9) and IEC 529.

## Other Application Considerations

	Non-Contact Switches	Hinge Switches	Tongue Switches	Limit Switches
Large Door	✓		✓	✓
Vibration	✓		✓	
Misalignment	✓	✓		
Debris	✓	✓		
Washdown	✓			✓

## Safety Switches

### Technology Overview

#### Tongue Interlock Switches



##### Features/Benefits

Tongue interlock switches are the most commonly used technology for door interlocking. They detect the movement of a guard using a key fitted to an opening in the switch body. Available in a variety of packages, contact configurations and degrees of holding force, these switches are generally the lowest-cost solution. The use of flexible keys also enhances tolerance to misalignment to address an even broader range of applications.

##### Applications

- Wide range of doors

##### Common Misapplications

- Washdown
- Heavy debris
- Cutting fluids
- Removable guards

#### Guard Locking Interlock Switches



##### Features/Benefits

Guard locking switches employ the same principle of operation as tongue interlocks, but feature an internal solenoid that locks the key—and therefore the guard—in place until the machine's power is isolated. Ideal for applications requiring controlled access to hazardous areas, guard locking switches are available in a variety of holding forces and with flexible actuators for optimal performance.

##### Applications

- Printing presses
- Large access doors
- Saws/cutting blades
- High inertia machinery
- Web machines

##### Common Misapplications

- Wet environments
- Improper holding force selected

3-Interlock  
Switches

#### Non-Contact Interlock Switches

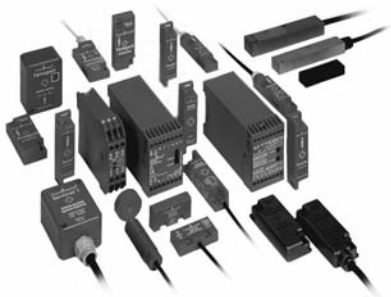

##### Features/Benefits

Since there is no contact between actuator and switch, non-contact switches offer simple setup and alignment, less wear, and superior tamper-resistance as well as reduced installation cost. In addition, the IP67- and IP69K-sealed plastic or stainless steel housings make them ideal for food processing applications and other harsh environments.

##### Applications

- Hinged doors
- A wide range of doors

##### Common Misapplications

- Mounted at the door hinge
- Mounted to mild steel
- Exposed to rapid temperature changes

## Safety Switches Technology Overview

### Hinge Interlock Switches



#### Features/Benefits

Hinge switches are designed to fit at the hinge point of swinging guards. Because they do not use keys which must slide into a slot in the switch body, hinge switches are ideal for machines with misaligned doors or applications with contaminants that could be caught in a key slot. Offering a higher integrity level than standard tongue interlocks, hinge switches are difficult to defeat and can be adjusted for the opening angle of the door.

#### Applications

- Hinged doors

#### Common Misapplications

- Large doors
- Doors with poor hinge alignment

### Limit Switches



#### Features/Benefits

Available in a variety of actuators and contact configurations, safety position (limit) switches satisfy Machinery Directive requirements. 802T limit switches with direct opening action offer positive opening safety contacts in a rugged NEMA-style housing for use in control reliable and other safety applications, while 440P IEC limit switches provide safety function in a compact, economical package.

#### Applications

- Conveyors
- Slide doors
- Muting sensors
- Robot positioning

#### Common Misapplications

- Mounting a single limit switch on a guard door

3-Interlock  
Switches

### Trapped Key Switches

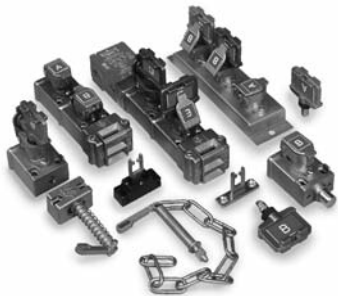

#### Features/Benefits

Prosafe™ trapped-key interlock switches are designed to provide power isolation, key exchange and interlocking for safety applications requiring a pre-defined sequence of operations. Most of these rugged products do not require power to operate, making them ideal for applications in remote or intrinsically safe locations. Stainless steel construction also allows their use in harsh environments for process/valve control.

#### Applications

- Sequencing/process control
- Intrinsic safety
- 1/4 turn valves

#### Common Misapplications

- Duplicate coded keys on the plant floor

## Safety Switches

### Interlock Switches

#### Overview

#### Versatility

Many safety switches allow the head of the switch to rotate, offering different options on how the switch can be operated and mounted on the guard. This offers flexibility to best fit typical applications.

#### Elf, Cadet3, MT-GD2, 440G-MT

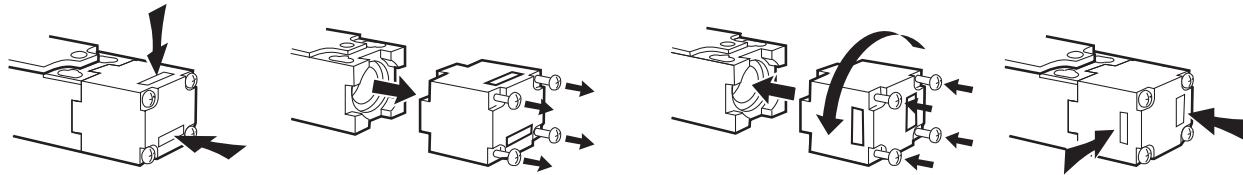

The head can be rotated 4 times at 90° allowing the key to fit the switch in 8 different positions.

#### Trojan T15, Trojan 5, Trojan 6 (Not GD2 Models)

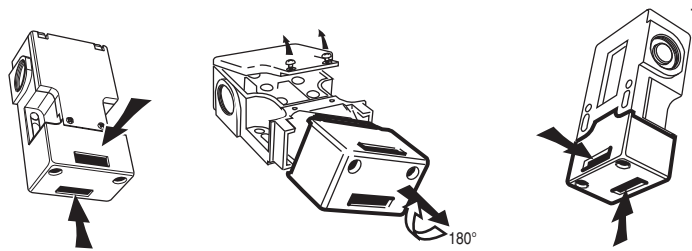

The head rotates 180° allowing the key to fit the switch in 4 different positions: 2 in the front, 1 in the top and 1 in the back.

#### TLS-GD2

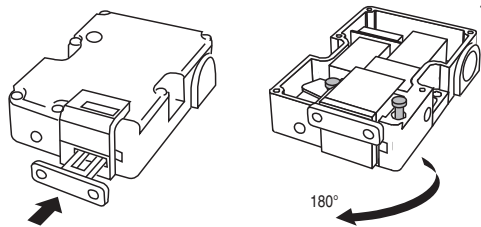

The head rotates 180° allowing the key to fit the switch in 4 different positions: 2 in the front, 1 in the top and 1 in the back.

#### 3-Interlock Switches

#### Sprite, Ensign

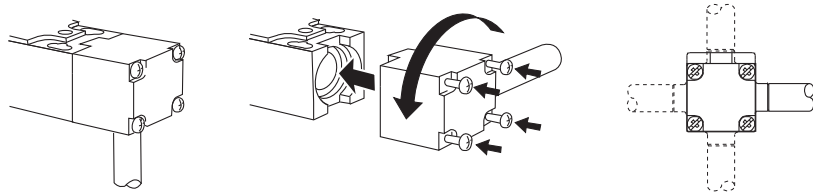

The head can be rotated 4 times at 90° allowing the switch to be mounted in 4 different positions.

## Safety Switches Interlock Switches Overview

### Accessories for Tongue and Guard Locking Switches



#### The correct actuator for your application

A large variety of tongue actuators are available:

*Standard:* 90°, Flat, Standard

*Flexible:* Semi and Fully

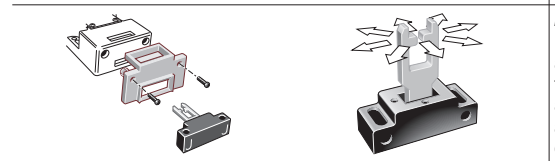
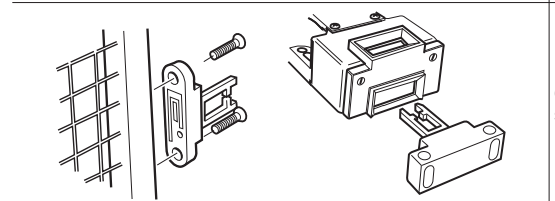
*Specialty:* Extended Flat and GD2 models

	<p><i>Standard type</i> actuators accommodate most of the applications. Their design allows for the actuator and the switch to be mounted in different position and the guard to work properly. The flat actuator is mounted on small rubber blocks allowing for some play when the guard closes. The 90° is typically used on sliding doors.</p>
	<p><i>Flexible type</i> actuators are used when doors are sagging or are not sturdy enough to guarantee insertion of the actuator always in-line with the opening of the switch. The flexible actuator allows for some motion of the actuator to "self" align with the opening of the switch. Fully flexible actuators allow the actuator to move within a 15° angle in any direction. Semi-flexible actuators can be used for tight angles where the actuator enters the switch at an angle. This angle is adjustable on the actuator. The semi-flexible actuator moves only in a single plan direction.</p>
	<p><i>GD2</i> actuators are dedicated actuators for GD2 models and are not suitable for use with standard models.</p>
	<p><i>Extended flat type</i> actuator is used mostly when the actuator is mounted on a chain and inserted in the switch. The guard is latched and the key is just inserted in the switch attached to a chain. When the door opens, the chain pulls the actuator activating the safety contacts.</p>















3-Interlock  
Switches

## Safety Switches

### Interlock Switches

#### Overview

#### Product Selection

Description	Elf	Cadet 3	T15	T15 GD2	T5-T6	T5 GD2-T6 GD2	MT-GD2	TLS GD2	Atlas 5	440G-MT	Cat. No.
Standard actuator 					✓						440K-A11095
Standard actuator 			✓								440K-A11238
Standard actuator 									✓		440G-A07136
GD2 standard actuator 				✓		✓	✓	✓		✓	440G-A27011
Flat actuator, not to be used with metal alignment guide 	✓	✓									440K-A21014
GD2 flat actuator 				✓		✓	✓	✓		✓	440K-A11112
90° actuator, not to be used with metal alignment guide 	✓	✓									440K-A21006
Fully flex actuator 				✓		✓	✓	✓		✓	440G-A27143
Fully flex actuator 									✓		440G-A07269
Extended flat actuator 				✓		✓	✓	✓		✓	440K-A17116
Metal alignment guide with semi-flexible actuator 	✓	✓									440K-A21030
Alignment guide with semi-flexible actuator 			✓	✓	✓	✓	✓				440K-A11144
Alignment guide with fully-flexible actuator 			✓		✓						440K-A27010
Catch and Retainer Kit 					✓						440K-A11094
Replacement Alignment Guide 					✓						440K-A11115

3-Interlock Switches



## Safety Switches Interlock Switches Overview

### Safety Switches and Connectors

Many interlock switches are offered with connectors allowing easy installation and replacement on-site, reducing downtime. Standard cordsets and connectors can be used to connect these products directly to:

- Terminal Blocks
- Safety Distribution Boxes
- ArmorBlock™ Guard I/O (IP 67 Safety I/O Blocks on DeviceNet™ Safety)

Type of Connectors	Cordset		Patchcord	ArmorBlock Guard I/O
	Terminal Block		Safety Distribution Box	
4-Pin Micro (M12)	✓		✓	
5-Pin Micro (M12)	✓			✓
6-Pin Micro (M12)	✓		✓	
8-Pin Micro (M12)	✓			
12-Pin M23	✓			

### Type of Connector by Product Family

Description	Interlock						Guard Locking		
	Elf	Cadet	Trojan T15	T5	T6	MT-GD2	TLS	Atlas 5	440G-MT
Connection to Distribution Box									
4-Pin Micro (M12)	✓		✓						
6-Pin Micro (M12)		✓		✓					
Connection to ArmorBlock Guard I/O									
5-Pin Micro (M12)	✓	✓	✓	✓		✓			
Other Connectors									
8-Pin Micro (M12)					✓	✓	✓	✓	✓
12-Pin M23						✓	✓	✓	✓

### Type of Connector by Product Family (continued)

Description	Non-Contact						Hinge			Cable Pull		
	Sensa-Guard	Ferrogard			Sipha		Sprite	Ensign	Rotacam	Lifeline		
		2, 20	21	6, 9, SS	S3	SS S4				3	4	SS 4
Connection to Distribution Box												
4-Pin Micro (M12)		✓		✓	✓		✓					
6-Pin Micro (M12)			✓					✓				
Connection to ArmorBlock Guard I/O												
5-Pin Micro (M12)	✓						✓	✓		✓	✓	
Other Connectors												
8-Pin Micro (M12)	✓					✓			✓	✓	✓	
12-Pin M23										✓	✓	✓

**Note:** All connectors on Safety Switches are male.

### Connectors Ratings

	Max. Ratings		Applicable Standards
	AC	DC	
4-Pin Micro (M12)	250V, 4 A	250V, 4 A	IEC 61076-2-101:2003
5-Pin Micro (M12)	60V, 4 A	60V, 4 A	IEC 61076-2-101:2003
6-Pin Micro (M12)	30V, 2 A	30V, 2 A	IEC 61076-2-101:2003
8-Pin Micro (M12)	30V, 2 A	30V, 2 A	IEC 61076-2-101:2003
12-Pin M23	63V, 6 A	63V, 6 A	IEC 61984:2001

3-Interlock  
Switches

## Safety Switches

# Tongue Switches

Elf™



### Description

The Elf is a tongue-operated (or key-operated) safety interlock switch designed to fit at the leading edge of sliding, hinged or lift-off guards. The Elf's unique miniature housing (only 75 x 25 x 29 mm (2.95 x 0.98 x 1.14 in.)) makes it the smallest interlock currently available. It is designed for smaller machines such as printers, copiers and domestic machinery which, until now, have been unable to use safety interlocks due to space restrictions. With its dual entry slots and rotatable head, the versatile Elf can offer up to eight different actuator entry options.

Operation of the switch is achieved through the insertion of a specially-profiled stainless-steel key that is permanently mounted to the guard door. The semi-flexible key allows the Elf to be used on small-radii doors (60 mm or 2.36 in.).

The Elf is available with a variety of contact configurations, conduit entry types and connectors. It is sealed to IP67 (watertight and dustproof). A blanking plug is supplied for the unused key entry.

### Features

- Ideal for small, lightweight guards
- The smallest interlock switch available
- Contacts, 2 N.C. or 1 N.O. and 1 N.C.
- Eight possible actuator entry points, easy to install
- Environmental protection: IP67
- GD2 style available for demanding applications

### Specifications

Safety Ratings	
Standards	EN954-1, ISO13849-1, IEC/EN60204-1, NFPA79, EN1088, ISO14119, IEC/EN60947-5-1, ANSI B11.19, AS4024.1
Safety Classification	Cat. 1 Device per EN954-1 Dual channel interlocks suitable for Cat. 3 or 4 systems
Certifications	CE Marked for all applicable directives, cULus, TÜV, and CCC

Outputs	
Safety Contacts * Direct Opening Action	1 N.C.      2 N.C.
Auxiliary Contacts	1 N.O.      None
Thermal Current/ $I_{th}$	5 A (10 A if A600)
Rated Insulation Voltage	2500V
Switching Current @ Voltage, Min.	5 mA @ 5V DC

Utilization Category					
A600/AC-15	(Ue)	600V	500V	240V	120V
	(Ie)	1.2 A	1.4 A	3.0 A	6.0 A
DC-13	(Ue)	24V			
	(Ie)	2 A			

Operating Characteristics	
Break Contact Force, Min.	6 N (1.35 lbf)
Actuation Speed, Max.	160 mm (6.29 in.)/s
Actuation Frequency, Max.	2 cycles/s
Operating Radius, Min	150 mm (5.90 in.) [60 mm (2.36 in.) with GD2 kit, min.]
Operating Life @ 100 mA load	1 x 10 <sup>6</sup> operations

Environmental	
Enclosure Type Rating	IP67
Operating Temperature [C (F)]	-20...+80° (-4...+176°)

Physical Characteristics	
Housing Material	UL Approved glass-filled PBT
Actuator Material	Stainless Steel
Weight [g (oz)]	60 (2.11)
Color	Red

\* Usable for ISO 13849-1:2006 and IEC 62061. Data other than B10d is based on:  
 - Usage rate of 1op/10 mins., 24 hrs/day, 360 days/year, representing 51840 operations per year  
 - Mission time/Proof test interval of 38 years

\* The safety contacts are described as normally closed (N.C.) i.e., with the guard closed, actuator in place (where relevant) and the machine able to be started.

## Safety Switches Tongue Switches Elf™

### Product Selection

Contact			Actuator Type	Cat. No.			
				M16 Conduit		Connector§	
Safety	Auxiliary	Action		M16	1/2 inch NPT Adaptor	Connect to Distribution Box 4-Pin Micro (M12)	Connect to ArmorBlock Guard I/O 5-Pin Micro (M12)
1 N.C.	1 N.O.	BBM	Flat	440K-E33036	440K-E33029	440K-E33074	—
			90°	<b>440K-E33040</b>	440K-E33030	440K-E33025	—
			GD2 Metal alignment guide w/semi-flex actuator	440K-E33034	440K-E33031	440K-E33075	—
			—	440K-E33014	440K-E33053	440K-E33076	—
2 N.C.	—	—	Flat	440K-E33080	440K-E33037	440K-E33077	440K-E2NNFPS
			90°	<b>440K-E33041</b>	440K-E33045	440K-E33024	—
			GD2 Metal alignment guide w/semi-flex actuator	—	440K-E33046	440K-E33078	440K-E2NNAPS
			—	<b>440K-E33047</b>	—	440K-E33079	—

§ For connector ratings see page 3-9.

§ With a 5-pin micro (M12) connector, not all contacts are connected. See *Typical Wiring Diagram* on page 3-13 for wiring details.

### Recommended Logic Interfaces

Description	Safety Outputs	Auxiliary Outputs	Terminals	Reset Type	Power Supply	Cat. Page No.	Cat. No.
<b>Single-Function Safety Relays for 2 N.C. Contact Switch</b>							
MSR127RP	3 N.O.	1 N.C.	Removable (Screw)	Monitored Manual	24V AC/DC	5-24	440R-N23135
MSR127TP	3 N.O.	1 N.C.	Removable (Screw)	Auto./Manual	24V AC/DC	5-24	440R-N23132
MSR30RT	2 N.O. Solid State	1 N.O. Solid State	Removable	Auto./Manual or Monitored Manual	24V DC	5-16	440R-N23198
<b>Single-Function Safety Relays for 1 N.C. &amp; 1 N.O. Contact Switch</b>							
MSR9T	2 N.O.	1 N.C.	Fixed	Auto./Manual	24V AC/DC	5-14	440R-F23027
MSR33RT	2 N.O. Solid State	1 N.O.	Removable	Auto. or Monitored Manual	24V DC SELV	5-18	440R-F23200
<b>Modular Safety Relays</b>							
MSR210P Base 2 N.C. only	2 N.O.	1 N.C. and 2 PNP Solid State	Removable	Auto./Manual or Monitored Manual	24V DC from the base unit	5-74	440R-H23176
MSR220P Input Module	—	—	Removable	—	24V DC	5-78	440R-H23178
MSR310P Base	MSR300 Series Output Modules	3 PNP Solid State	Removable	Auto./Manual Monitored Manual	24V DC	5-94	440R-W23219
MSR320P Input Module	—	2 PNP Solid State	Removable	—	24V DC from the base unit	5-98	440R-W23218

**Note:** For additional Safety Relays connectivity, see the Safety Relays section (page 5-8) of this catalog.  
 For additional Safety I/O and Safety PLC connectivity, see the Programmable Safety System section (page 5-107) of this catalog.  
 For application and wiring diagrams, see the Safety Applications section (page 10-1) of this catalog.

### Connection Systems

Description	Connection to Distribution Box 4-Pin Micro (M12)		Connection to ArmorBlock Guard I/O 5-Pin Micro (M12)
	1 N.C. & 1 N.O.	2 N.C.	2 N.C.
Cordset	889D-F4AC-*	889D-F4AC-*	—
Patchcord	889D-F4ACDM-*	889D-F4ACDM-*	889R-F5ECRM-*
Distribution Box	898D-P4†KT-DM4	898D-4‡LT-DM4	—
Shorting Plug	898D-41KU-DM	898D-41LU-DM	—
T-Port	898D-43KY-D4	898D-43LY-D4	—

\* Replace symbol with 2 (2 m), 5 (5 m), or 10 (10 m) for standard cable lengths.

‡ Replace symbol with 1 (1 m), 2 (2 m), 3 (3 m), 5 (5 m), or 10 (10 m) for standard cable lengths.

† Replace symbol with 4 or 8 for number of ports.

**Note:** For additional information, see the Safety Connection System section (page 7-1) of this catalog.







**3-Interlock Switches**

# Safety Switches

## Tongue Switches

EIF™

### Accessories

	Description	Dimensions	Cat. No.
	Flat actuator, not to be used with metal alignment guide	3-52	440K-A21014
	90° actuator, not to be used with metal alignment guide	3-52	440K-A21006
	Metal alignment guide with semi-flexible actuator	3-52	440K-A21030
	Metal Alignment Guide	3-52	440K-A21069
	Replacement Cover	—	440A-A33085
	Dust Cover	—	440K-A17182

**3-Interlock Switches**

### Approximate Dimensions

Dimensions are shown in mm (in.). Dimensions are not intended to be used for installation purposes.

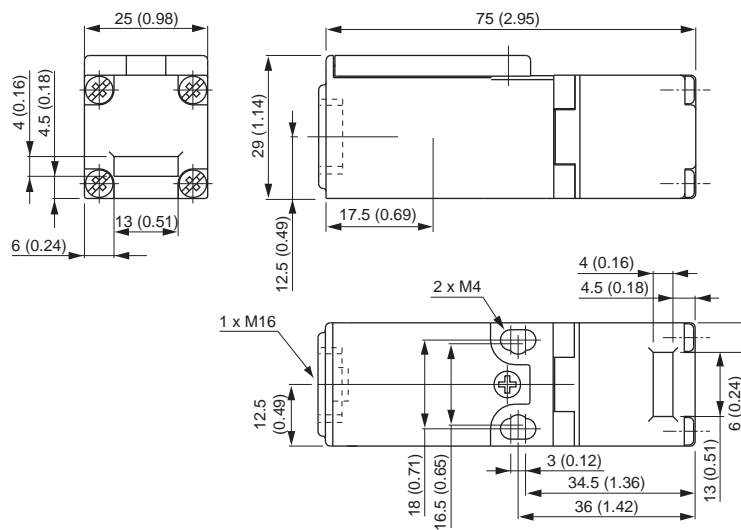
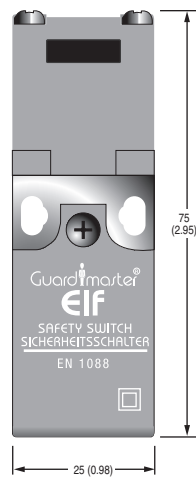

## Safety Switches Tongue Switches Elf™

### Typical Wiring Diagrams

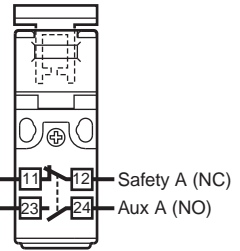
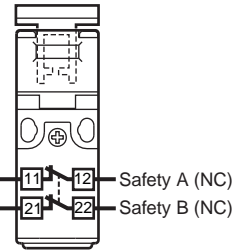
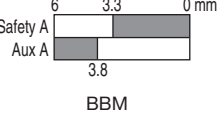
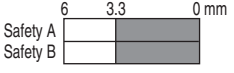
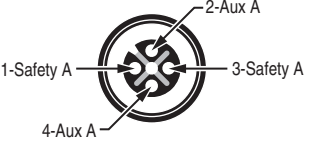
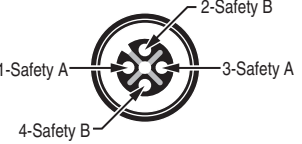
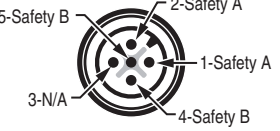
Description	1 N.C. & 1 N.O.	2 N.C.												
Contact Configuration 														
Contact Action <input type="checkbox"/> Open <input checked="" type="checkbox"/> Closed	 <p style="text-align: center;">BBM</p>													
4-Pin Micro (M12)														
5-Pin Micro (M12) For ArmorBlock Guard I/O	—													
Cordset 889D-F4AC-*	<table border="1"> <tr><td>Brown</td><td>Safety A</td></tr> <tr><td>Blue</td><td>Safety A</td></tr> <tr><td>White</td><td>Aux A</td></tr> <tr><td>Black</td><td>Aux A</td></tr> </table>	Brown	Safety A	Blue	Safety A	White	Aux A	Black	Aux A	<table border="1"> <tr><td>Safety A</td><td>Safety A</td></tr> <tr><td>Safety B</td><td>Safety B</td></tr> </table>	Safety A	Safety A	Safety B	Safety B
Brown	Safety A													
Blue	Safety A													
White	Aux A													
Black	Aux A													
Safety A	Safety A													
Safety B	Safety B													

\* Replace symbol with 2 (2 m), 5 (5 m) or 10 (10 m) for standard cable lengths.

3-Interlock  
Switches

## Safety Switches

### Tongue Switches

#### Cadet™ 3



#### Description

The Cadet 3 is a tongue-operated (or key-operated) safety interlock switch designed to fit at the leading edge of sliding, hinged or lift-off guards. With its dual entry slots and rotatable head, the versatile Cadet 3 can offer up to eight different actuator entry options. The unique compact housing (90.5 x 31 x 30.4 mm (3.56 x 1.22 x 1.19 in.)) has industry standard DIN 50047 fixing centers for ease of mounting.

Operation of the switch is achieved through the insertion of a specially-profiled stainless-steel key that is permanently mounted to the guard door. A semi-flexible key allows the Cadet 3 to be used on small-radius doors (60 mm or 2.36 in.).

Available with a variety of contact configurations, the Cadet 3 is sealed to IP67. A blanking plug is supplied for the unused key entry.

#### Features

- Compact size
- Ideal for small, lightweight guards
- Contacts, 2 N.C. and 1 N.O. or 3 N.C.
- Sealed to IP67
- Eight possible actuator entry points, easy to install
- Industry standard fixing centres to DIN 50047
- GD2 style available for demanding applications

#### Specifications

Safety Ratings					
Standards	EN954-1, ISO13849-1, IEC/EN60204-1, NFPA79, EN1088, ISO14119, IEC/EN60947-5-1, ANSI B11.19, AS4024.1				
Safety Classification	Cat. 1 device per EN 954-1 dual channel interlocks suitable for Cat. 3 or 4 systems				
Certifications	CE Marked for all applicable directives, cULus, TÜV, and CCC				
Outputs					
Safety Contacts *	2 N.C.	3 N.C.			
Direct Opening Action					
Auxiliary Contacts	1 N.O.	None			
Thermal Current/ $I_{th}$	10 A				
Rated Insulation Voltage	(U <sub>i</sub> ) 500V				
Switching Current @ Voltage, Min.	5 mA @ 5V DC				
Utilization Category					
A600/AC-15	(U <sub>e</sub> )	600V	500V	240V	120V
	(I <sub>e</sub> )	1.2 A	1.4 A	3.0 A	6.0 A
DC-13	(U <sub>e</sub> )	24V			
	(I <sub>e</sub> )	2 A			
Operating Characteristics					
Break Contact Force, Min.	15 N (3.37 lbf)				
Actuation Speed, Max.	160 mm (6.29 in.)/s				
Actuation Frequency, Max.	2 cycles/s				
Operating Radius, Min	150 mm (5.90 in.) [60 mm (2.36 in.) with GD2 kit]				
Operating Life @ 100 mA load	1 x 10 <sup>6</sup> operations				
Environmental					
Enclosure Type Rating	IP67				
Operating Temperature [C (F)]	-20...+ 80° (-4...+176°)				
Physical Characteristics					
Housing Material	UL Approved glass-filled PBT				
Actuator Material	Stainless Steel				
Weight [g (lb)]	80 (0.176)				
Color	Red				

\* Usable for ISO 13849-1:2006 and IEC 62061. Data other than B10d is based on:  
 - Usage rate of 1op/10 mins., 24 hrs/day, 360 days/year, representing 51840 operations per year  
 - Mission time/Proof test interval of 38 years

\* The safety contacts are described as normally closed (N.C.) i.e., with the guard closed, actuator in place (where relevant) and the machine able to be started.

## Safety Switches

# Tongue Switches

### Cadet™ 3

### Product Selection

Contact			Actuator Type	Cat. No.			
Safety	Auxiliary	Action		M16 Conduit		Connector§	
				M16	1/2 inch NPT Adaptor	Connect to Distribution Box 6-Pin Micro (M12)	Connect to ArmorBlock Guard I/O 5-Pin Micro (M12)*
3 N.C.	—	—	Flat	440K-C21096	440K-C21048	440K-C21090	440K-C2NNFPS
			90°	440K-C21097	440K-C21057	440K-C21091	—
			GD2 Metal alignment guide w/semi-flex actuator	—	440K-C21062	440K-C21092	440K-C2NNAPS
			—	440K-C21070	—	—	—
2 N.C.	1 N.O.	BBM	Flat	440K-C21098	440K-C21050	440K-C21054	—
			90°	<b>440K-C21061</b>	440K-C21058	440K-C21067	—
			GD2 Metal alignment guide w/semi-flex actuator	—	<b>440K-C21074</b>	<b>440K-C21088</b>	—
			—	440K-C21055	—	—	—
		MBB	Flat	440K-C21052	440K-C21093	440K-C21060	—
			90°	440K-C21065	440K-C21094	440K-C21068	—
			GD2 Metal alignment guide w/semi-flex actuator	—	440K-C21095	440K-C21089	—
			—	440K-C21080	—	—	—

§ For connector ratings see page 3-9.

\* With a 5-pin micro (M12) connector, not all contacts are connected. See *Typical Wiring Diagram* on page 3-17 for wiring details.

### Recommended Logic Interfaces

Description	Safety Outputs	Auxiliary Outputs	Terminals	Reset Type	Power Supply	Cat. Page No.	Cat. No.
<b>Single-Function Safety Relays</b>							
MSR127RP	3 N.O.	1 N.C.	Removable (Screw)	Monitored Manual	24V AC/DC	5-24	440R-N23135
MSR127TP	3 N.O.	1 N.C.	Removable (Screw)	Auto./Manual	24V AC/DC	5-24	440R-N23132
MSR126T	2 N.O.	None	Fixed	Auto./Manual	24V AC/DC	5-22	440R-N23117
MSR30RT	2 N.O. Solid State	1 N.O. Solid State	Removable	Auto./Manual or Monitored Manual	24V DC	5-16	440R-N23198
<b>Modular Safety Relays</b>							
MSR210P Base 2 N.C. only	2 N.O.	1 N.C. and 2 PNP Solid State	Removable	Auto./Manual or Monitored Manual	24V DC from the base unit	5-74	440R-H23176
MSR220P Input Module	—	—	Removable	—	24V DC	5-78	440R-H23178
MSR310P Base	MSR300 Series Output Modules	3 PNP Solid State	Removable	Auto./Manual Monitored Manual	24V DC	5-94	440R-W23219
MSR320P Input Module	—	2 PNP Solid State	Removable	—	24V DC from the base unit	5-98	440R-W23218

**Note:** For additional Safety Relays connectivity, see the Safety Relays section (page 5-8) of this catalog.

For additional Safety I/O and Safety PLC connectivity, see the Programmable Safety System section (page 5-107) of this catalog.

For application and wiring diagrams, see the Safety Applications section (page 10-1) of this catalog.

### Connection Systems

Description	6-Pin Micro (M12)	5-Pin Micro (M12)
Cordset	889R-F6ECA-*	—
Patchcord	889R-F6ECRM-*	889R-F5ECRM-*
Distribution Box	898R-P68MT-A5	—
Shorting Plug	898R-P61MU-RM	—
T-Port	NA	—

\* Replace symbol with 2 (2 m), 5 (5 m), or 10 (10 m) for standard cable lengths.

\* Replace symbol with 1 (1 m), 2 (2 m), 3 (3 m), 5 (5 m), or 10 (10 m) for standard cable lengths.





**Note:** For additional information, see the Safety Connection System section (page 7-1) of this catalog.

# Safety Switches

## Tongue Switches

### Cadet™ 3

#### Accessories

	Description	Dimensions	Cat. No.
	Flat actuator, not to be used with metal alignment guide	3-52	440K-A21014
	90° actuator, not to be used with metal alignment guide		440K-A21006
	Metal alignment guide with semi-flexible actuator		440K-A21030
	Replacement Cover	—	440A-A21115
	Dust Cover	—	440K-A17182

#### Approximate Dimensions

Dimensions are shown in mm (in.). Dimensions are not intended to be used for installation purposes.

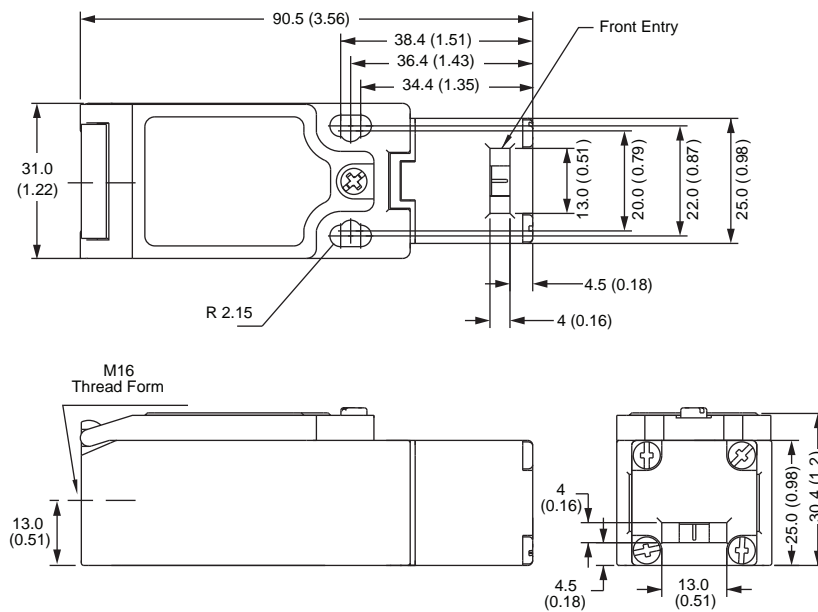

Note: 2D, 3D and electrical drawings are available on [www.ab.com](http://www.ab.com).

3-Interlock Switches



## Safety Switches Tongue Switches Cadet™ 3

### Typical Wiring Diagrams

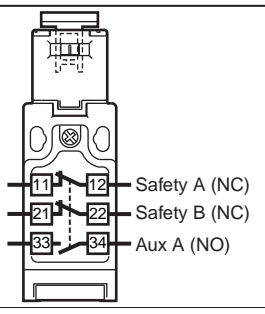
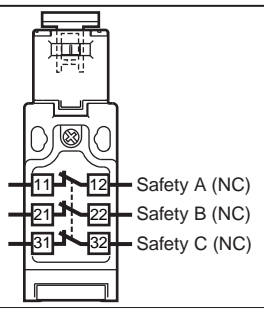
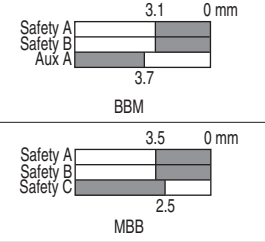
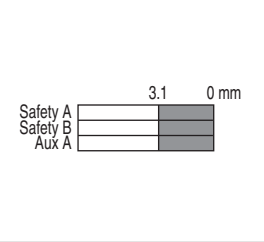
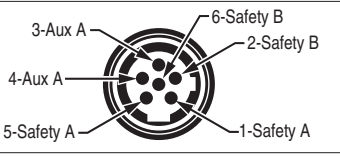
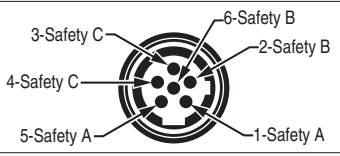
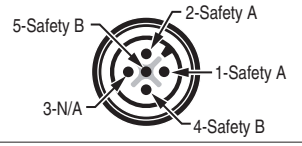
Description	2 N.C. & 1 N.O.	3 N.C.																		
Contact Configuration																				
Contact Action  <input type="checkbox"/> Open <input checked="" type="checkbox"/> Closed																				
6-Pin Micro (M12)																				
5-Pin Micro (M12)	—																			
Cordset 889R-F6ECA- <i>*</i>	<table border="1"> <tr><td>Red/White</td><td>Safety A</td></tr> <tr><td>Red/Black</td><td>Safety A</td></tr> <tr><td>Red</td><td>Safety B</td></tr> <tr><td>Red/Blue</td><td>Safety B</td></tr> <tr><td>Green</td><td>Aux A</td></tr> <tr><td>Red/Yellow</td><td>Aux A</td></tr> </table>	Red/White	Safety A	Red/Black	Safety A	Red	Safety B	Red/Blue	Safety B	Green	Aux A	Red/Yellow	Aux A	<table border="1"> <tr><td>Safety A</td><td>Safety A</td></tr> <tr><td>Safety B</td><td>Safety B</td></tr> <tr><td>Safety C</td><td>Safety C</td></tr> </table>	Safety A	Safety A	Safety B	Safety B	Safety C	Safety C
Red/White	Safety A																			
Red/Black	Safety A																			
Red	Safety B																			
Red/Blue	Safety B																			
Green	Aux A																			
Red/Yellow	Aux A																			
Safety A	Safety A																			
Safety B	Safety B																			
Safety C	Safety C																			

\* Replace symbol with 2 (2 m), 5 (5 m) or 10 (10 m) for standard cable lengths.

3-Interlock  
Switches

## Safety Switches

### Tongue Switches

#### Trojan™ T15

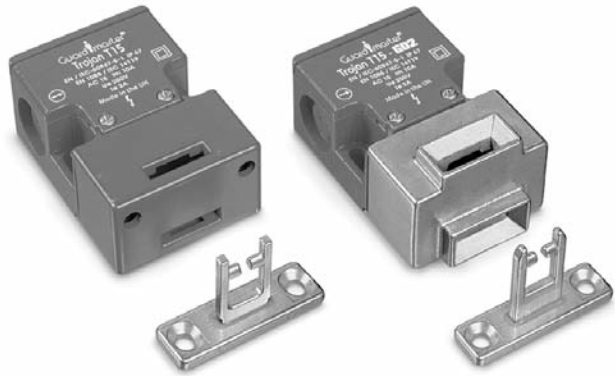

#### Description

The Trojan T15 is a compact universal tongue-operated (or key-operated) safety interlock switch designed to fit at the leading edge of sliding, hinged or lift-off guards. With its dual entry slots and rotatable head, movable only by releasing the cover screws, the Trojan T15 can offer four different options for actuator entry.

The Trojan T15 features a compact housing, only 75 x 52 x 32 mm (2.95 x 2.04 x 1.25 in.) and includes direct opening action contacts and a tamper-resistant mechanism. The Trojan T15 has 2 N.C. safety contacts or 1 N.C. safety contact and 1 N.O. auxiliary contact. The unit is sealed to IP67 and has three M20 conduit entries.

Operation of the switch is achieved by the insertion of the specially-profiled stainless-steel actuator which should be permanently fixed to the leading edge of the guard door. The standard T15 incorporates actuator retention force of 30N. An optional catch mechanism helps keep doors shut on vibrating machinery.

#### Features

- Compact size, 75 x 52 x 32 mm (2.95 x 2.05 x 1.26 in.) case
- 30 N actuator retention force
- Strong and versatile, can be used in most applications
- Contacts: 2 N.C. safety or 1 N.C. safety & 1 N.O. auxiliary
- GD2 style available for demanding applications

#### Specifications

Safety Ratings					
Standards	EN954-1, ISO13849-1, IEC/EN60204-1, NFPA79, EN1088, ISO14119, IEC/EN60947-5-1, ANSI B11.19, AS4024.1				
Safety Classification	Cat. 1 device per EN 954-1 dual channel interlocks suitable for Cat. 3 or 4 systems				
Certifications	CE Marked for all applicable directives, cULus, TÜV, and CCC				
Outputs					
Safety Contacts *	2 N.C.	1 N.C.			
Direct Opening Action					
Auxiliary Contacts	None	1 N.O.			
Thermal Current/ $I_{th}$	10 A				
Rated Insulation Voltage	(U <sub>i</sub> ) 500V				
Switching Current @ Voltage, Min.	5 mA @ 5V DC				
Utilization Category					
A600/AC-15 (U <sub>e</sub> )	(U <sub>e</sub> )	600V	500V	240V	120V
(I <sub>e</sub> )	(I <sub>e</sub> )	1.2 A	1.4 A	3.0 A	6.0 A
DC-13 (U <sub>e</sub> )	(U <sub>e</sub> )	24V			
(I <sub>e</sub> )	(I <sub>e</sub> )	2 A			
Operating Characteristics					
Break Contact Force, Min.	30 N (6.70 lbf)				
Actuation Speed, Max.	160 mm (6.29 in.)/s				
Actuation Frequency, Max.	2 cycles/s				
Operating Radius, Min	175 mm (6.89 in.) [60 mm (2.36 in.) with flexible actuator]				
Operating Life @ 100 mA load	1 x 10 <sup>6</sup> operations				
Environmental					
Enclosure Type Rating	IP67				
Operating Temperature [C (F)]	-20...+80° (-4...+176°)				
Physical Characteristics					
Housing Material	UL Approved glass-filled PBT				
Actuator Material	Stainless Steel				
Weight [g (lb)]	120 (0.265)				
Color	Red				

\* Usable for ISO 13849-1:2006 and IEC 62061. Data other than B10d is based on:  
 - Usage rate of 1op/10 mins., 24 hrs/day, 360 days/year, representing 51840 operations per year  
 - Mission time/Proof test interval of 38 years

\* The safety contacts are described as normally closed (N.C.) i.e., with the guard closed, actuator in place (where relevant) and the machine able to be started.

## Safety Switches Tongue Switches Trojan™ T15

### Product Selection

Type	Contact		Contact Action	Actuator Type	Cat. No.			
	Safety	Auxiliary			M20 Conduit		Connector§	
					M20	1/2 inch NPT Adaptor	Connect to Distribution Box 4-Pin Micro (M12)	Connect to ArmorBlock Guard I/O 5-Pin Micro (M12)
Trojan T15 Standard	2 N.C.	—	—	Standard	440K-T11303	440K-T11267	440K-T11307	440K-V2NNSPS
				Fully-Flex	440K-T11395	440K-T11273	440K-T11384	440K-V2NNBPS
				—	<b>440K-T11269</b>	—	440K-T11385	—
	1 N.C.	1 N.O.	BBM	Standard	440K-T11305	440K-T11268	440K-T11386	—
				Fully-Flex	440K-T11396	440K-T11276	440K-T11387	—
				—	440K-T11270	—	440K-T11388	—
Trojan T15 GD2	2 N.C.	—	—	GD2 Standard	440K-T11463	440K-T11288	440K-T11389	440K-V2NNGPS-NG
				Fully-Flex	440K-T11397	440K-T11287	440K-T11390	—
				—	440K-T11280	—	440K-T11391	—
	1 N.C.	1 N.O.	BBM	GD2 Standard	440K-T11398	440K-T11284	440K-T11392	—
				Fully-Flex	440K-T11399	440K-T11283	440K-T11393	—
				—	440K-T11279	—	440K-T11394	—

§ For connector ratings see page 3-9.

### Recommended Logic Interfaces

Description	Safety Outputs	Auxiliary Outputs	Terminals	Reset Type	Power Supply	Cat. Page No.	Cat. No.
<b>Single-Function Safety Relays for 2 N.C. Contact Switch</b>							
MSR127RP	3 N.O.	1 N.C.	Removable (Screw)	Monitored Manual	24V AC/DC	5-24	440R-N23135
MSR127TP	3 N.O.	1 N.C.	Removable (Screw)	Auto./Manual	24V AC/DC	5-24	440R-N23132
MSR30RT	2 N.O. Solid State	1 N.O. Solid State	Removable	Auto./Manual or Monitored Manual	24V DC	5-16	440R-N23198
<b>Single-Function Safety Relays for 1 N.C. &amp; 1 N.O. Contact Switch</b>							
MSR9T	2 N.O.	1 N.C.	Fixed	Auto./Manual	24V AC/DC	5-14	440R-F23027
MSR33RT	2 N.O. Solid State	1 N.O.	Removable	Auto. or Monitored Manual	24V DC SELV	5-18	440R-F23200
<b>Modular Safety Relays</b>							
MSR210P Base 2 N.C. only	2 N.O.	1 N.C. and 2 PNP Solid State	Removable	Auto./Manual or Monitored Manual	24V DC from the base unit	5-74	440R-H23176
MSR220P Input Module	—	—	Removable	—	24V DC	5-78	440R-H23178
MSR310P Base	MSR300 Series Output Modules	3 PNP Solid State	Removable	Auto./Manual Monitored Manual	24V DC	5-94	440R-W23219
MSR320P Input Module	—	2 PNP Solid State	Removable	—	24V DC from the base unit	5-98	440R-W23218

**Note:** For additional Safety Relays connectivity, see the Safety Relays section (page 5-8) of this catalog.  
 For additional Safety I/O and Safety PLC connectivity, see the Programmable Safety System section (page 5-107) of this catalog.  
 For application and wiring diagrams, see the Safety Applications section (page 10-1) of this catalog.

### Connection Systems

Description	Connection to Distribution Box 4-Pin Micro (M12)		Connection to ArmorBlock Guard I/O 5-Pin Micro (M12)
	2 N.C.	1 N.C. & 1 N.O.	2 N.C.
Cordset	889D-F4AC-*	889D-F4AC-*	—
Patchcord	889D-F4ACDM-*	889D-F4ACDM-*	889D-F5ACDM-*
Distribution Box	898D-4†LT-DM4	898D-P4‡KT-DM4	—
Shorting Plug	898D-41LU-DM	898D-41KU-DM	—
T-Port	898D-43LY-D4	898D-43KY-D4	—

\* Replace symbol with 2 (2 m), 5 (5 m), or 10 (10 m) for standard cable lengths.  
 † Replace symbol with 1 (1 m), 2 (2 m), 3 (3 m), 5 (5 m), or 10 (10 m) for standard cable lengths.  
 ‡ Replace symbol with 4 or 8 for number of ports.  
**Note:** For additional information, see the Safety Connection System section (page 7-1) of this catalog.

**3-Interlock Switches**

## Safety Switches

### Tongue Switches

#### Trojan™ T15

#### Accessories

Description	To Be Used With:	Dimensions	Cat. No.
 Standard actuator	Trojan T15 Standard Models Only	3-51	440K-A11238
 GD2 standard actuator	Trojan GD2 Models Only	3-50	<b>440G-A27011</b>
 GD2 flat actuator	Trojan GD2 Models Only	3-51	<b>440K-A11112</b>
 Alignment guide with semi-flexible actuator	Discard Alignment Guide for GD2 Models		440K-A11144
 Alignment guide with fully-flexible actuator	Discard Alignment Guide for GD2 Models		3-52
 Sliding bolt actuator	Trojan GD2 Models Only	3-55	440G-A27163
 Catch and Retainer Kit	Trojan T15 Standard Models Only	3-50	440K-A11094
 Replacement Cover	All Models	—	440A-A11499
 Dust Cover	All Models	—	440K-A17180

3-Interlock Switches

#### Approximate Dimensions

Dimensions are shown in mm (in.). Dimensions are not intended to be used for installation purposes.

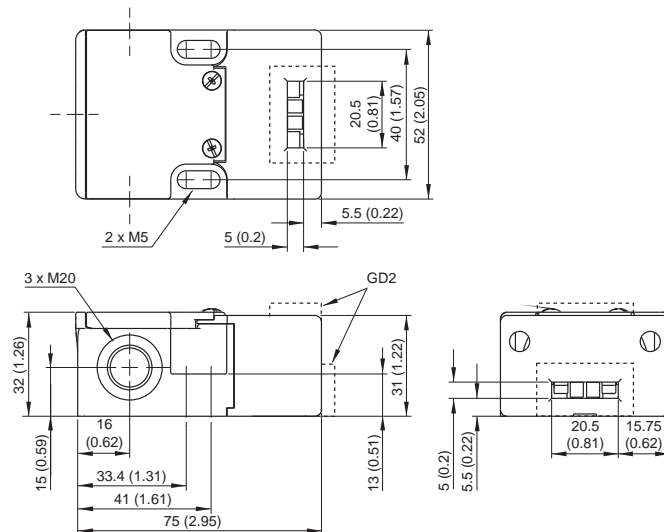

**Note:** 2D, 3D and electrical drawings are available on [www.ab.com](http://www.ab.com).

## Safety Switches Tongue Switches Trojan™ T15

### Typical Wiring Diagrams

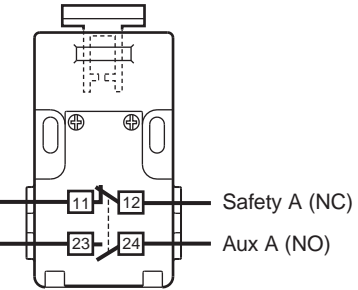
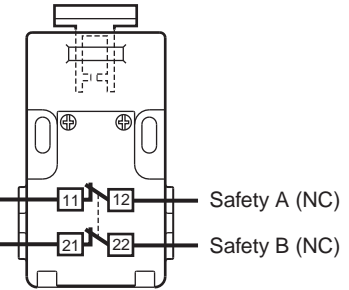
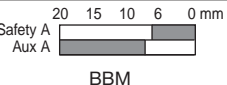
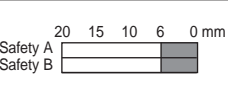
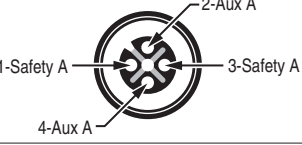
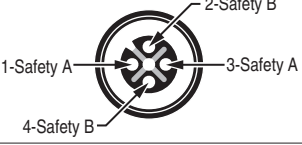
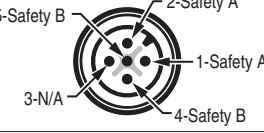
Description		1 N.C. & 1 N.O.	2 N.C.
Contact Configuration			
Contact Action □ Open ■ Closed			
4-Pin Micro (M12)			
5-Pin Micro (M12) For ArmorBlock Guard I/O		—	
Cordset 889D-F4AC-*	Brown	Safety A	Safety A
	Blue	Safety A	Safety A
	White	Aux A	Safety B
	Black	Aux A	Safety B

\* Replace symbol with 2 (2 m), 5 (5 m) or 10 (10 m) for standard cable lengths.

**3-Interlock  
Switches**

## Safety Switches

### Tongue Switches

#### Trojan™ 5 & 6

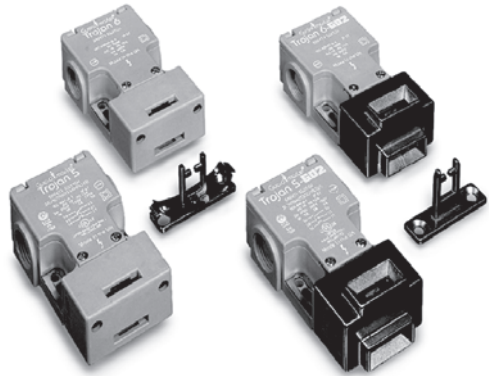

#### Description

The Trojan family is a universal tongue-operated (or key-operated) safety-interlock switch designed to fit at the leading edge of sliding, hinged or lift-off guards. The dual key entry slots and rotatable head, movable only by releasing the cover screws, allow four actuator entry options. The Trojan contains all of the safety related functions—i.e., forced guided contacts, tamper resistant mechanism—allowing the machine to be safeguarded in compliance with the machine directive.

Operation of the switch is achieved through the insertion of a specially-profiled stainless-steel key that is permanently mounted to the leading edge of the guard door. The standard (not GD2) Trojan actuator includes a self-ejecting mechanism that prevents operation of the switch if the actuator is not mounted to the guard door (e.g., if the operator uses a spare key).

#### Features

- Strong and versatile, can be used in most applications
- Self-ejecting tamper resistant actuator, only operates when mounted to the guard (not with GD2 models)
- Four possible actuator entry points, easy to install
- GD2 style available for demanding applications

3-Interlock Switches

#### Specifications

Safety Ratings				
Standards	EN 954-1, ISO 13849-1, IEC/EN 60204-1, NFPA 79, EN 1088, ISO 14119, IEC/EN 60947-5-1, ANSI B11.19, AS 4024.1			
Safety Classification	Cat. 1 device per EN 954-1 dual channel interlocks suitable for Cat. 3 or 4 systems			
Functional Safety Data *	B10d: > 2 x 10 <sup>6</sup> operations at min. load PFH <sub>D</sub> : > 3 x 10 <sup>-7</sup> MTTFd: > 385 years Dual channel interlock may be suitable for performance levels Plc or Pld (according to ISO 13849-1:2006) and for use in SIL2 or SIL3 systems (according to IEC 62061) depending on application characteristics			
Note:	For up-to-date information, visit <a href="http://www.ab.com/Safety/">http://www.ab.com/Safety/</a>			
Certifications	CE Marked for all applicable directives, cULus, TÜV, and CCC			
Outputs				
Safety Contacts * Direct Opening Action	3 N.C.	2 N.C.	2 N.C.	
Auxiliary Contacts	1 N.O.	2 N.O.	1 N.O.	
Thermal Current/I <sub>th</sub>	10 A			
Rated Insulation Voltage	(U <sub>i</sub> ) 500V			
Switching Current @ Voltage, Min.	5 mA @ 5V DC			
Utilization Category				
<b>Trojan 5</b> A300/AC-15	(Ue)	240V	120V	
	(Ie)	3 A	6 A	
DC-13	(Ue)	24V	24V	
	(Ie)	2 A		
<b>Trojan 6</b> A600/AC-15	(Ue)	600V	500V	240V 120V
	(Ie)	1.2 A	1.4 A	3 A 6 A
DC-13	(Ue)	24V		
	(Ie)	2 A		
Operating Characteristics				
Break Contact Force, Min.	Trojan 5: 12 N (2.7 lbf) & 30 N (6.75 lbf) Trojan 6: 20 N (4.5 lbf)			
Actuation Speed, Max.	160 mm (6.29 in.)/s			
Actuation Frequency, Max.	2 cycles/s			
Operating Radius, Min	175 mm (6.89 in.) [60 mm (2.36 in.) with flexible actuator]			
Operating Life @ 100 mA load	1 x 10 <sup>6</sup> operations			
Environmental				
Enclosure Type Rating	IP67			
Operating Temperature [C (F)]	-20...+80° (-4...+176°)			
Physical Characteristics				
Housing Material	UL Approved glass-filled PBT			
Actuator Material	Stainless Steel			
Weight [g (lb)]	160 (0.35)			
Color	Red			

\* Usable for ISO 13849-1:2006 and IEC 62061. Data other than B10d is based on:  
 - Usage rate of 1op/10 mins., 24 hrs/day, 360 days/year, representing 51840 operations per year  
 - Mission time/Proof test interval of 38 years

\* The safety contacts are described as normally closed (N.C.) i.e., with the guard closed, actuator in place (where relevant) and the machine able to be started.

Safety Switches  
**Tongue Switches**  
Trojan™ 5 & 6

Product Selection

Type	Contact			Actuator Type	Cat. No.			
	Safety	Auxiliary	Action		M20 Conduit		Connector§	
					M20	1/2 inch NPT Adaptor	Connect to Distribution Box 6-Pin Micro (M12)	Connect to ArmorBlock Guard I/O 5-Pin Micro (M12)*
Trojan 5 Standard	2 N.C.	1 N.O.	BBM	Standard	440K-T11090	440K-T11202	440K-T11205	—
				Guide/Semi-Flex	440K-T11110	440K-T11203	440K-T11206	—
				Guide/Fully-Flex	440K-T11467	440K-T11204	440K-T11207	440K-T2NNBPS
				—	440K-T11089	—	440K-T11129	—
			BBM Gold Contacts	Standard	440K-T11085	—	—	—
				—	—	—	—	—
			MBB	Standard	440K-T11118	440K-T11208	440K-T11224	—
				Guide/Semi-Flex	440K-T11123	440K-T11209	440K-T11363	—
Guide/Fully-Flex	440K-T11468	440K-T11210		440K-T11364	—			
—	440K-T11146	440K-T11469		440K-T11365	—			
Trojan 5 GD2	2 N.C.	1 N.O.	BBM	GD2 Standard	440K-T11336	440K-T11211	440K-T11366	440K-T2NNGPS-NG
				Guide/Semi-Flex	440K-T11337	440K-T11212	440K-T11367	—
				Guide/Fully-Flex	440K-T11338	440K-T11213	440K-T11368	—
				—	440K-T11147	—	440K-T11226	—
			MBB	GD2 Standard	440K-T11339	440K-T11470	440K-T11369	—
				Guide/Semi-Flex	440K-T11340	440K-T11471	440K-T11370	—
				Guide/Fully-Flex	440K-T11341	440K-T11472	440K-T11371	—
				—	440K-T11167	—	440K-T11372	—
Trojan 5 30 N			BBM	Standard	440K-T11333	440K-T91024	440K-T11492	—

§ For connector ratings see page 3-9.

\* With a 5-pin micro (M12) connector, not all contacts are connected. See *Typical Wiring Diagram* on page 3-27 for wiring details.

Type	Contact			Actuator Type	Cat. No.		
	Safety	Auxiliary	Action		M20 Conduit		Connector§
					M20	1/2 inch NPT Adaptor	8-Pin Micro (M12)*
Trojan 6	3 N.C.	1 N.O.	BBM	Standard	440K-T11171	440K-T11435	—
				—	440K-T11449	440K-T11408	—
	2 N.C.	2 N.O.	BBM	Standard	440K-T11174	440K-T11438	—
				—	440K-T11452	440K-T11416	440K-W21BNPH
			MBB	—	440K-T11453	440K-T11454	440K-W21MNPH
Trojan 6 GD2	3 N.C.	1 N.O.	BBM	GD2 Standard	440K-T11418	440K-T11466	—
				—	440K-T11188	440K-T11444	—
			—	440K-T11456	440K-T11457	—	
	2 N.C.	2 N.O.	BBM	GD2 Standard	440K-T11445	440K-T11425	—
				—	440K-T11459	440K-T11433	440K-W21BNPH-NG
			—	440K-T11460	440K-T11461	440K-W21MNPH-NG	

§ For connector ratings see page 3-9.

\* With an 8-pin micro (M12) connector, not all contacts are connected. See *Typical Wiring Diagram* on page 3-27 for wiring details.

3-Interlock Switches

## Safety Switches

### Tongue Switches

#### Trojan™ 5 & 6

#### Recommended Logic Interfaces

Description	Safety Outputs	Auxiliary Outputs	Terminals	Reset Type	Power Supply	Cat. Page No.	Cat. No.
<b>Single-Function Safety Relays</b>							
MSR127RP	3 N.O.	1 N.C.	Removable (Screw)	Monitored Manual	24V AC/DC	5-24	440R-N23135
MSR127TP	3 N.O.	1 N.C.	Removable (Screw)	Auto./Manual	24V AC/DC	5-24	440R-N23132
MSR126T	2 N.O.	None	Fixed	Auto./Manual	24V AC/DC	5-22	440R-N23117
MSR30RT	2 N.O. Solid State	1 N.O. Solid State	Removable	Auto./Manual or Monitored Manual	24V DC	5-16	440R-N23198
<b>Modular Safety Relays</b>							
MSR210P Base 2 N.C. only	2 N.O.	1 N.C. and 2 PNP Solid State	Removable	Auto./Manual or Monitored Manual	24V DC from the base unit	5-74	440R-H23176
MSR220P Input Module	—	—	Removable	—	24V DC	5-78	440R-H23178
MSR310P Base	MSR300 Series Output Modules	3 PNP Solid State	Removable	Auto./Manual Monitored Manual	24V DC	5-94	440R-W23219
MSR320P Input Module	—	2 PNP Solid State	Removable	—	24V DC from the base unit	5-98	440R-W23218

**Note:** For additional Safety Relays connectivity, see the Safety Relays section (page 5-8) of this catalog.  
For additional Safety I/O and Safety PLC connectivity, see the Programmable Safety System section (page 5-107) of this catalog.  
For application and wiring diagrams, see the Safety Applications section (page 10-1) of this catalog.

#### Connection Systems

Description	Trojan 5		Trojan 6
	5-Pin Micro (M12)	6-Pin Micro (M12)	8-Pin Micro (M12)
Cordset	—	889R-F6ECA-*	889D-F8AB-*
Patchcord	889R-F5ECRM-*	889R-F6ECRM-*	889D-F8ABDM-*
Distribution Box	—	898R-F68MT-A5	—
Shorting Plug	—	898R-P61MU-RM	—
T-Port	—	—	—

\* Replace symbol with 2 (2 m), 5 (5 m), or 10 (10 m) for standard cable lengths.

⚡ Replace symbol with 1 (1 m), 2 (2 m), 3 (3 m), 5 (5 m), or 10 (10 m) for standard cable lengths.

‡ Replace symbol with 4 or 8 for number of ports.

**Note:** For additional information, see the Safety Connection System section (page 7-1) of this catalog.

3-Interlock  
Switches



Safety Switches  
**Tongue Switches**  
Trojan™ 5 & 6

**Accessories**

	Description	To Be Used With:	Dimensions	Cat. No.
	Standard actuator	Trojan T5 and T6 Standard Models Only	3-51	440K-A11095
	GD2 standard actuator	GD2 Models Only	3-50	440G-A27011
	GD2 flat actuator	GD2 Models Only	3-51	440K-A11112
	Alignment guide with semi-flexible actuator	Discard Alignment Guide for GD2 Models	3-51	440K-A11144
	Alignment guide with fully-flexible actuator	Discard Alignment Guide for GD2 Models	3-52	440K-A27010
	Sliding bolt actuator	GD2 Models Only	3-55	440G-A27163
	Catch and Retainer Kit	Trojan T5 and T6 Standard Models Only	3-50	440K-A11094
	Replacement Cover	Trojan T5 Standard Models Only	—	440A-A11495
		Trojan T5 GD2		440A-A11496
		Trojan T6 Standard Models Only		440A-A11497
		Trojan T6 GD2		440A-A11498
	Dust Cover	All Models	—	440K-A17180

**3-Interlock  
Switches**

# Safety Switches

## Tongue Switches

### Trojan™ 5 & 6

#### Approximate Dimensions

Dimensions are shown in mm (in.). Dimensions are not intended to be used for installation purposes.

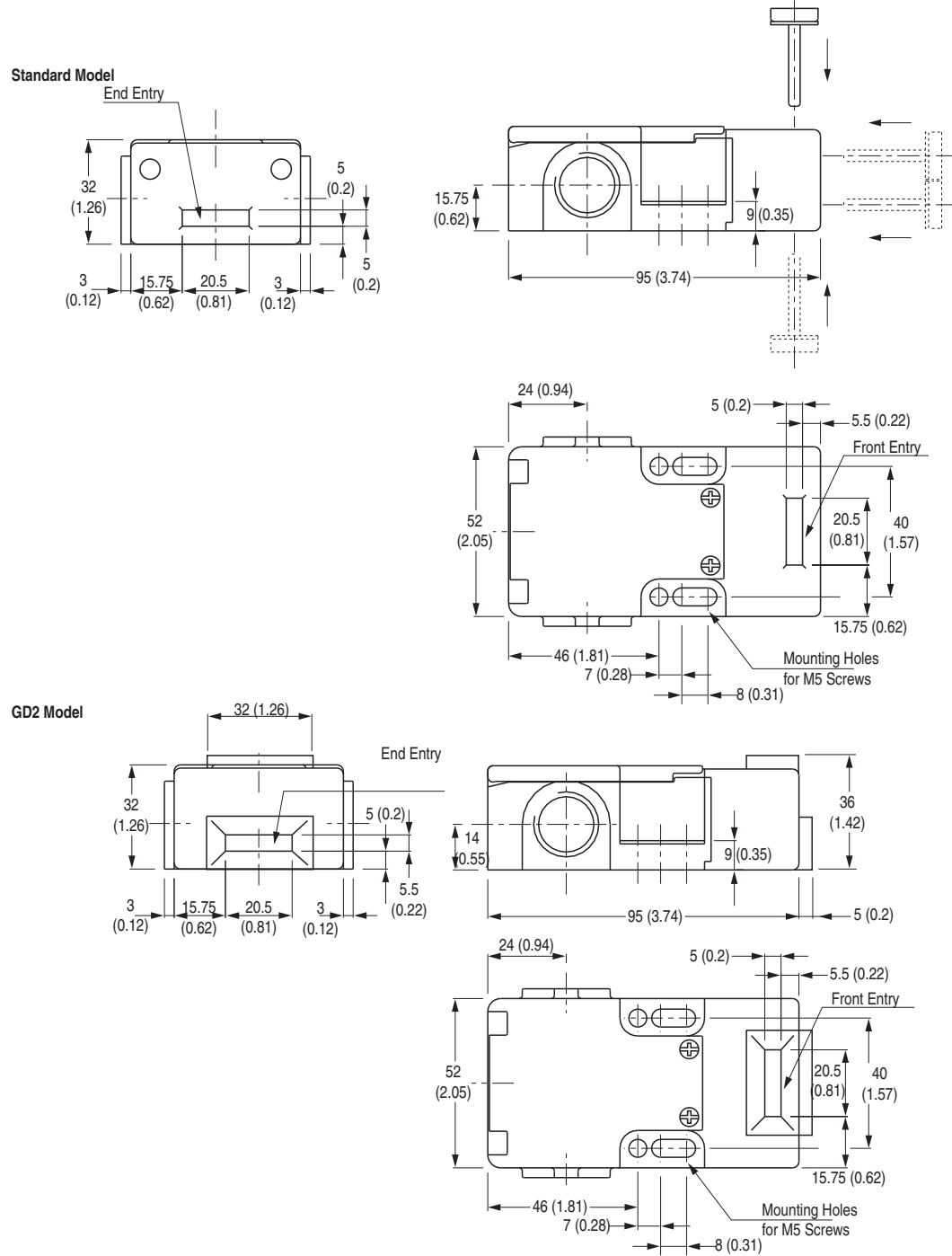

Note: 2D, 3D and electrical drawings are available on [www.ab.com](http://www.ab.com).

3-Interlock  
Switches

## Safety Switches Tongue Switches Trojan™ 5 & 6

### Typical Wiring Diagrams

Description	Trojan 5		Trojan 6	
	2 N.C. & 1 N.O.		2 N.C. & 2 N.O.	3 N.C. & 1 N.O.
Contact Configuration				
Contact Action	<p style="text-align: center;">BBM</p> <p style="text-align: center;">MBB</p>		<p style="text-align: center;">BBM</p> <p style="text-align: center;">MBB</p>	<p style="text-align: center;">BBM</p> <p style="text-align: center;">MBB</p>
6-Pin Micro (M12)			—	—
5-Pin Micro (M12) for ArmorBlock Guard I/O			—	—
8-Pin Micro (M12)	—			—
6-Pin Cordset 889R-F6ECA-*	Red/White	Safety A		—
	Red/Black	Safety A		—
	Red	Safety B		—
	Red/Blue	Safety B		—
	Green	Aux		—
8-Pin Cordset 889D-F8AB-*	Grey Red	—		Safety A
	Yellow Pink	—		Safety B
	White Blue	—		Aux A
	Green Brown	—		NA

\* Replace symbol with 2 (2 m), 5 (5 m) or 10 (10 m) for standard cable lengths.

**3-Interlock  
Switches**

# Safety Switches

## Tongue Switches

### MT-GD2



#### Description

The MT-GD2 family is a robust, tongue-operated (or key-operated) safety-interlock switch designed to fit at the leading edge of sliding, hinged or lift-off guards. With its dual entry slots and rotatable head, the MT-GD2 can offer eight different options for actuator entry.

The MT-GD2 features a compact housing of only 117 x 40 x 43 mm (4.60 x 1.57 x 1.69 in.) with DIN 50041 standard fixing centres and includes forced guided contacts and a tamper-resistant mechanism.

The MT-GD2 is available with a variety of contact configurations enabling it to be used as part of a system for higher-risk applications. Operation of the switch is achieved by the insertion of the specially-profiled stainless-steel actuator which should be permanently fixed to the leading edge of the guard door. An optional flexible actuator allows the MT-GD2 to operate on smaller-radius doors ( $\geq 60$  mm) and a flat actuator gives additional mounting options, for example, on a chain.

A style incorporating a latch release mechanism allows manual retention of the actuator in the switch until the release mechanism is manually activated.

#### Features

- Strong and versatile, can be used in most applications
- Eight possible actuator entry points, easy to install
- Variety of contact configurations
- Snap acting MT-GD2 gives a min. break contact force of 40 N
- Optional latch release styles
- Industry standard fixing centers to DIN/EN50041

#### MT-GD2 Latch Release Style

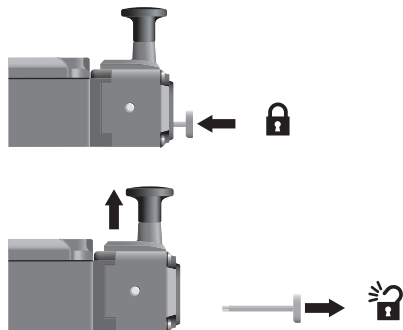

#### Specifications

Safety Ratings					
Standards	EN954-1, ISO13849-1, IEC/EN60204-1, NFPA79, EN1088, ISO14119, IEC/EN60947-5-1, ANSI B11.19, AS4024.1				
Safety Classification	Cat. 1 device per EN 954-1 dual channel interlocks suitable for Cat. 3 or 4 systems				
Functional Safety Data * Note: For up-to-date information, visit <a href="http://www.ab.com/Safety/">http://www.ab.com/Safety/</a>	B10d: $> 2 \times 10^6$ operations at min. load PFH <sub>D</sub> : $> 3 \times 10^{-7}$ MTTFd: $> 385$ years Dual channel interlock may be suitable for performance levels Pl <sub>e</sub> or Pl <sub>d</sub> (according to ISO 13849-1:2006) and for use in SIL2 or SIL3 systems (according to IEC 62061) depending on application characteristics				
Certifications	CE Marked for all applicable directives, cULus, TÜV, and CCC				
Outputs					
Safety Contacts *	Standard: 3 N.C. or 2 N.C. direct opening action Snap acting: 2 N.C. direct opening forced disconnection				
Auxiliary Contacts	Standard: 1 N.O. or 2 N.O. Snap Acting: 2 N.O.				
Thermal Current <sub>I<sub>th</sub></sub>	10 A				
Rated Insulation Voltage	(U <sub>i</sub> ) 500V				
Switching Current @ Voltage, Min.	5 mA @ 5V DC				
Utilization Category					
A600/AC-15	(U <sub>e</sub> )	600V	500V	240V	120V
	(I <sub>e</sub> )	1.2 A	1.4 A	3 A	6 A
Standard—DC-13	(U <sub>e</sub> )	24V			
	(I <sub>e</sub> )	2 A			
Snap-Acting—A300/AC-15	(U <sub>e</sub> )	240V	120V		
	(I <sub>e</sub> )	3 A	6 A		
Snap-Acting—DC-13	(U <sub>e</sub> )	24V			
	(I <sub>e</sub> )	2 A			
Operating Characteristics					
Break Contact Force, Min.	BBM & MBB: 12 N (2.7 lbf) BBM & Extended Flat Actuator: 32 N (7.2 lbf) Snap acting: 40 N (9.0 lbf)				
Actuation Speed, Max.	160 mm (6.29 in.)/s				
Actuation Frequency, Max.	2 cycles/s				
Operating Life @ 100 mA load	1 x 10 <sup>6</sup> operations				
Environmental					
Enclosure Type Rating	IP67				
Operating Temperature [C (F)]	-20...+80° (-4...+176°)				
Physical Characteristics					
Housing Material	Painted zinc				
Actuator Material	Stainless Steel				
Weight [g (lb)]	520 (1.15)				
Color	Yellow or Red				

\* Usable for ISO 13849-1:2006 and IEC 62061. Data other than B10d is based on:

- Usage rate of 1op/10 mins., 24 hrs/day, 360 days/year, representing 51840 operations per year
- Mission time/Proof test interval of 38 years

\* The safety contacts are described as normally closed (N.C.) i.e., with the guard closed, actuator in place (where relevant) and the machine able to be started.

Safety Switches  
**Tongue Switches**  
 MT-GD2

**Product Selection**  
**Red Body Switches**

Type	Contact			Actuator Type	Cat. No.					
	Safety	Auxiliary	Action		Conduit		Connector§			
					M20	1/2 in NPT	12-Pin M23	8-Pin Micro (M12)*	Connect to ArmorBlock Guard I/O 5-Pin Micro (M12)*	
MT-GD2	3 N.C.	1 N.O.	BBM	—	<b>440K-MT55002</b>	440K-MT55085	440K-MT55094	—	—	
				GD2 Standard	440K-MT55074	<b>440K-MT55022</b>	<b>440K-MT55095</b>	—	—	
				Fully Flexible	440K-MT55075	<b>440K-MT55029</b>	<b>440K-MT55096</b>	—	—	
			MBB	—	440K-MT55004	<b>440K-MT55088</b>	440K-MT55100	—	—	
	2 N.C.	2 N.O.	BBM	—	<b>440K-MT55005</b>	440K-MT55086	440K-MT55097	440K-M21BNDH	—	
				GD2 Standard	<b>440K-MT55076</b>	<b>440K-MT55026</b>	440K-MT55098	—	—	
				Fully Flexible	440K-MT55077	<b>440K-MT55087</b>	440K-MT55099	—	—	
			MBB	—	440K-MT55006	440K-MT55089	440K-MT55101	—	—	
			Snap Acting	—	—	440K-M22ANDT	440K-M22ANDL	440K-M21ANDH	440K-M2NNNDS	—
				Extended Flat	440K-M22AEDM	<b>440K-M22AEDT</b>	—	—	—	—
				GD2 Standard	440K-M22ASDM	440K-M22ASDT	—	—	—	—
				Fully Flexible	440K-M22ABDM	440K-M22ABDT	—	—	—	—
MT-GD2 Latch Release	3 N.C.	1 N.O.	BBM	—	<b>440K-MT55039</b>	440K-MT55062	440K-MT55042	—		
				GD2 Standard	<b>440K-MT55078</b>	440K-MT55041	440K-MT55070	—	—	
				Fully Flexible	440K-MT55079	440K-MT55045	440K-MT55103	—	—	
			MBB	—	440K-MT55082	440K-MT55091	440K-MT55106	—	—	
	2 N.C.	2 N.O.	BBM	—	440K-MT55063	440K-MT55065	440K-MT55066	440K-M21BNDH-N5	440K-M2NNNDS-N5	
				GD2 Standard	440K-MT55080	<b>440K-MT55050</b>	440K-MT55104	—	—	
				Fully Flexible	440K-MT55081	440K-MT55051	440K-MT55052	—	—	
			MBB	—	440K-MT55083	440K-MT55092	440K-MT55105	440K-M21MNDH-N5	—	

**3-Interlock Switches**

§ For connector ratings see page 3-9.  
 \* With a 5-pin micro (M12) connector, not all contacts are connected. See *Typical Wiring Diagram* on page 3-32 for wiring details.  
 \* With an 8-pin micro (M12) connector, not all contacts are connected. See *Typical Wiring Diagram* on page 3-32 for wiring details.

**Yellow Body Switches**

Type	Contact			Actuator Type	Cat. No.		
	Safety	Auxiliary	Action		Conduit	Connector§	
					1/2 in NPT	12-Pin M23	5-Pin Micro (M12)*
MT-GD2	2 N.C.	2 N.O.	Snap Acting	—	<b>440K-M22ANYT</b>	—	—
—	2 N.C.	2 N.O.	MBB	Extended Flat	<b>440K-M22AEYT</b>	440K-M22AEYL	440K-M2NAEYS
—	2 N.C.	2 N.O.	MBB	—	440K-M22MNYT-N5	—	440K-M2NNNYS-N5

§ For connector ratings see page 3-9.  
 \* With a 5-pin micro (M12) connector, not all contacts are connected. See *Typical Wiring Diagram* on page 3-32 for wiring details.  
 \* With an 8-pin micro (M12) connector, not all contacts are connected. See *Typical Wiring Diagram* on page 3-32 for wiring details.

## Safety Switches

### Tongue Switches

#### MT-GD2

#### Recommended Logic Interfaces

Description	Safety Outputs	Auxiliary Outputs	Terminals	Reset Type	Power Supply	Cat. Page No.	Cat. No.
<b>Single-Function Safety Relays</b>							
MSR127RP	3 N.O.	1 N.C.	Removable (Screw)	Monitored Manual	24V AC/DC	5-24	440R-N23135
MSR127TP	3 N.O.	1 N.C.	Removable (Screw)	Auto./Manual	24V AC/DC	5-24	440R-N23132
MSR126T	2 N.O.	None	Fixed	Auto./Manual	24V AC/DC	5-22	440R-N23117
MSR30RT	2 N.O. Solid State	1 N.O. Solid State	Removable	Auto./Manual or Monitored Manual	24V DC	5-16	440R-N23198
<b>Modular Safety Relays</b>							
MSR210P Base 2 N.C. only	2 N.O.	1 N.C. and 2 PNP Solid State	Removable	Auto./Manual or Monitored Manual	24V DC from the base unit	5-74	440R-H23176
MSR220P Input Module	—	—	Removable	—	24V DC	5-78	440R-H23178
MSR310P Base	MSR300 Series Output Modules	3 PNP Solid State	Removable	Auto./Manual Monitored Manual	24V DC	5-94	440R-W23219
MSR320P Input Module	—	2 PNP Solid State	Removable	—	24V DC from the base unit	5-98	440R-W23218

**Note:** For additional Safety Relays connectivity, see the Safety Relays section (page 5-8) of this catalog.  
 For additional Safety I/O and Safety PLC connectivity, see the Programmable Safety System section (page 5-107) of this catalog.  
 For application and wiring diagrams, see the Safety Applications section (page 10-1) of this catalog.

#### Connection Systems

Description	4-Pin Micro (M12)	5-Pin Micro (M12)	8-Pin Micro (M12)	12-Pin M23
Cordset	889D-F4AC-*	—	889D-F8AB-*	889M-FX9AE-*
Patchcord	889D-F4ACDM-*	889D-F5ACDM-*	889D-F8ABDM-*	—
Distribution Box	898D-P4†LT-DM4	—	—	—
Shorting Plug	898D-41LU-DM	—	—	—
T-Port	898D-43LY-D4	—	—	—







\* Replace symbol with 2 (2 m), 5 (5 m), or 10 (10 m) for standard cable lengths.  
 † Replace symbol with 1 (1 m), 2 (2 m), 3 (3 m), 5 (5 m), or 10 (10 m) for standard cable lengths.  
 ‡ Replace symbol with 4 or 8 for number of ports.

**Note:** For additional information, see the Safety Connection System section (page 7-1) of this catalog.

3-Interlock  
Switches

Safety Switches  
**Tongue Switches**  
 MT-GD2

**Accessories**

Description	Dimensions	Cat. No.
 GD2 standard actuator	3-50	440G-A27011
 GD2 flat actuator	3-51	440K-A11112
 Fully flex actuator	3-50	440G-A27143
 Sliding bolt actuator	3-55	440G-A27163
 Extended flat actuator	3-51	440K-A17116
 Dust Cover	—	440K-A17180

**Approximate Dimensions**

Dimensions are shown in mm (in.). Dimensions are not intended to be used for installation purposes.

**MT-GD2 Latch Release**

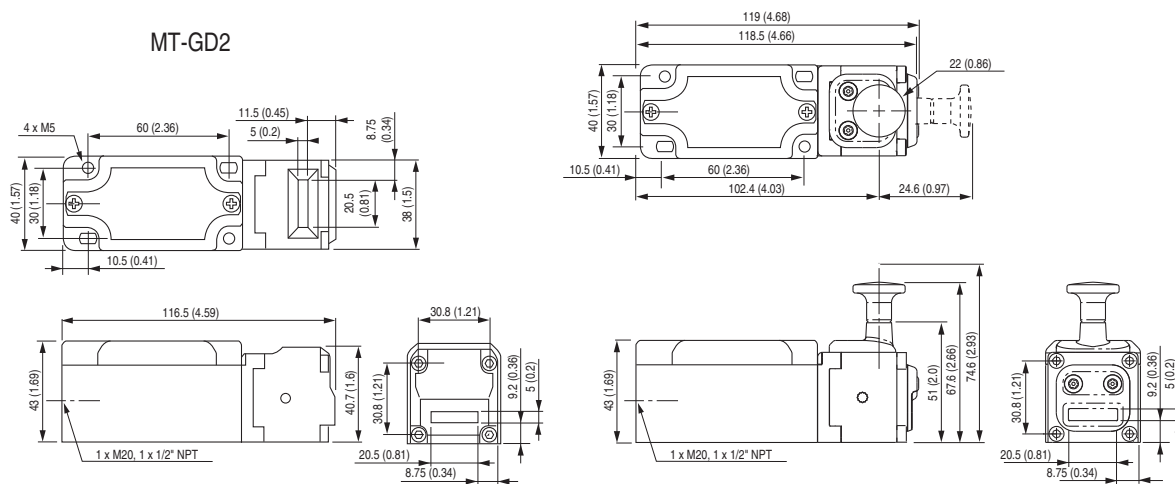

**Note:** 2D, 3D and electrical drawings are available on [www.ab.com](http://www.ab.com).

**3-Interlock  
Switches**

# Safety Switches

## Tongue Switches

### MT-GD2

#### Typical Wiring Diagrams

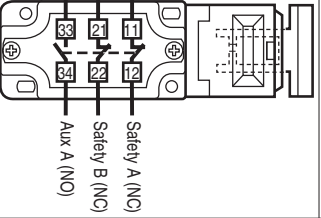
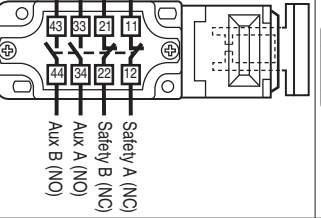
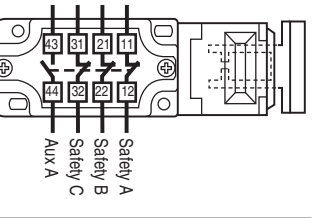
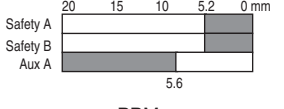
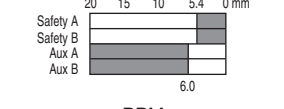
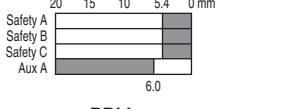
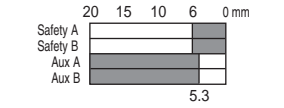
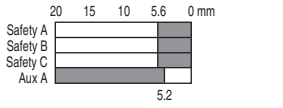
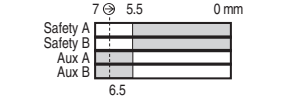
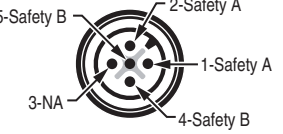
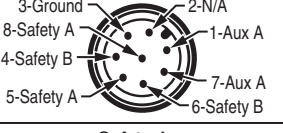
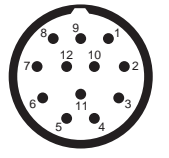
Description	2 N.C. & 1 N.O.	2 N.C. & 2 N.O.	3 N.C. & 1 N.O.	
Contact Configuration				
Contact Action	 <p>BBM</p>	 <p>BBM</p>	 <p>BBM</p>	
<input type="checkbox"/> Open <input checked="" type="checkbox"/> Closed	—	 <p>MBB</p>	 <p>MBB</p>	
	—	 <p>Snap Acting</p>	—	
5-Pin Micro (M12) for Connection to ArmorBlock Guard I/O	—		—	
8-Pin Micro (M12)	—		—	
12-Pin Cordset	1 and 3 4 and 6 7 and 8 9 and 10 12	Safety A Safety B NC Aux A Ground	Safety A Safety B Aux A Aux B Ground	Safety A Safety B Safety C Aux A Ground
 <p>Pins 2, 5 and 11 are not connected.</p>				
8-Pin Cordset 889D-F8AB-*	Grey Red Yellow Pink White Blue Green Brown	— — — — —	Safety A Safety B Aux A Ground Not Used	— — — — —
12-Pin Cordset 889M-FX9AE-*	Brown Blue White Green Yellow Grey Pink Red Green/Yellow	Safety A Safety B Not Used Aux A Ground	Safety A Safety B Aux A Aux B Ground	Safety A Safety B Safety C Aux A Ground

\* Replace symbol with 2 (2 m), 5 (5 m) or 10 (10 m) for standard cable lengths.

3-Interlock Switches



## Safety Switches

# Guard Locking Switches

### Overview

#### Overview

Guard locking switches are used to protect hazardous areas where a danger is not immediately removed after a stop request. On many machines removal of power of the motor or actuator will not necessarily cause a reliable and immediate stopping of the dangerous motion. Typical applications are: high inertia rotating machines, fast rotating machines, and machines where high pressure needs to be released from pneumatic valves.

Gates protected with guard locking switches are usually opened on exception basis. For example: to clear a jam or to regularly maintain the machine. This type of switch should not be used for frequent access during normal operation of the machine.

Guard locking switches use a solenoid to activate a lock which blocks or releases the tongue from the switch.

Rockwell Automation offers two different types of guard locking switches:

#### Power to Lock

When power is applied to the solenoid, the tongue is locked in the switch. When power is removed, the lock is released allowing the tongue to be extracted from the switch.

#### Power to Release

When power is applied to the solenoid the lock is released allowing the tongue to be extracted from the switch. When power is removed, the tongue is locked in the switch.

#### Why Use Power to Lock or Power to Release?

	Power to Lock	Power to Release
Advantage	When the power is removed from the cell after a "controlled stop," the doors unlock allowing maintenance personnel to go in easily.	Power is not applied to the switch all the time, only when the door needs to be opened. Sudden lose of power does not compromise safety of personnel, as the doors stay closed.
Disadvantage	Sudden lose of power will unlock the door allowing personnel to go in the hazardous area and the machine may not be stopped.	Loss of power will not unlock the door and maintenance personnel will not be able to go inside the cell.

Different methodologies can help decrease the risk that the danger is removed before the operator has access to the hazardous area:

#### Time based

The risk assessment process and stop time measurement will determine the maximum time for the machine to stop from its normal speed of operation. This time defines the delay between the request to open the gate and the authorization to access the zone by unlocking the gate by energizing (Power to Release) or de-energizing (Power to Lock) the solenoid.

This time delay can be implemented by using any of our time delay units such as the MSR178 or MSR138 safety relay or by software in one of our Safety PLC.

#### Stop motion

Another methodology is to measure when the motion is stopped. When the no-motion is detected, the lock is released to allow personnel to enter the hazardous zone.

The CU2, CU3, or MSR57 safety relay will be used to detect the motion is stopped.

#### Safe speed conditions

In some applications, the user may need access while the machine is running at a safe speed. The MSR57P used with encoder technology can handle this application. It will verify the speed of the motion and allow access only if the speed does not exceed a preconfigured limit or otherwise the machine will enter a stop condition.

#### Typical Sequence of Actions

1. The operator requests to enter the hazardous area
2. A controlled or immediate stop of the machine is initiated
3. The machine is stopped: time delay expired or stop motion detected
4. The gate is unlocked by either energizing (Power to Release) or de-energizing (Power to Lock) the solenoid
5. The operator opens the gate and works in the hazardous area
6. The operator exits the hazardous area and closes the gate
7. The operator restarts the machine
8. The gate is locked by either de-energizing (Power to Release) or energizing (Power to Lock) the solenoid
9. The machine returns to its normal speed

#### Manual Override

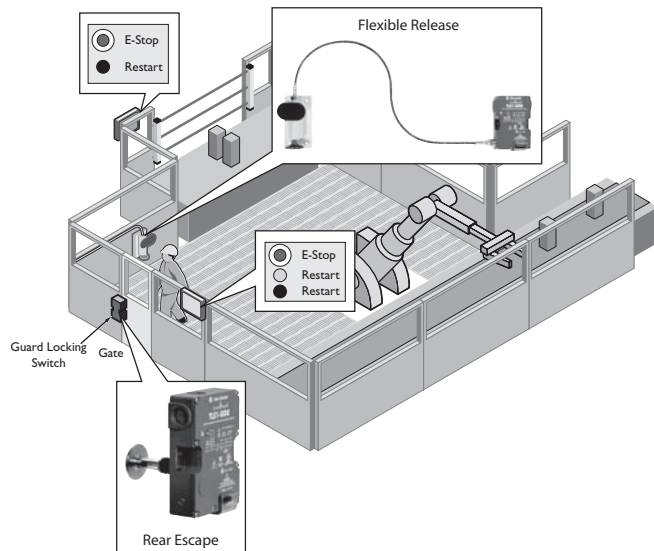

In the situation where a person is still in the hazardous area, the door is locked and the machine restarts, the TLS guard locking switch product family provides two options for the person to escape the hazard (in addition of an Emergency Stop located outside of the hazardous area):

#### Option 1: Rear Escape (Not Latched)

A 40 mm push button is mounted on the back of the TLS and is accessible from the inside of the cell. Pushing the rear escape push button releases the lock mechanism inside the TLS guard locking switch allowing the door to be opened, the machine to stop and the person to escape the hazardous area.

#### Option 2: Flexible Release (Latched)

The flexible release push button accessory is designed to be installed inside the hazardous area to provide a means of escape for personnel who become trapped there. It provides remote access to the manual release mechanism within the TLS-GD2 switch in the event of an emergency situation. The flexible release can be retro-fitted to existing TLS1-GD2 and TLS3-GD2 switches or installed along with a new switch.

The unit is installed at an accessible height next to the guard door, inside the guarded area, while the TLS-GD2 can be mounted outside the guarded area. The flexible release is available with either a 1 m (3.28 ft) or a 3 m (9.84 ft) cable.

Pushing the black button on the flexible release, the movement of the cable activates the release mechanism within the switch, allowing the door to be opened, the machine to stop and the person to escape the hazardous area. The flexible release is then reset using the blue reset handle.



3-Interlock  
Switches

# Safety Switches





## Guard Locking Switches

### Overview

#### Selection Guide

	440G-MT	TLS1-GD2	TLS2-GD2	TLS3-GD2	Atlas 5
<b>Product</b>					
<b>Holding Force</b>	1600 N (360 lb)	2000 N (450 lb)			5000 N (1124 lb)
<b>Housing Material</b>	Metal	Plastic			Metal
<b>Locking Mechanism</b>	Power to Release	Power to Release	Power to Lock	Power to Release	Power to Release
<b>Escape Release</b>	None	Rear Escape and Flexible Release	None	Rear Escape and Flexible Release	None
<b>Safety Contacts</b>	2 N.C.	3 N.C.	2 N.C.		2 N.C.
<b>Aux Contacts</b>	2 N.O.	1 N.O.	1 N.O.		1 N.O.
<b>Solenoid Monitoring</b>	Direct Drive	1 N.O. & 1 N.C.		2 N.C.	2 N.C.

#### Typical Sequence of Actions and Contact Status

Step		440G-MT	TLS1	TLS2	TLS3	Atlas 5
Step 1—Hazardous Area Protected 	<b>Solenoid Power</b>	<b>De-energized</b>	<b>De-energized</b>	<b>Energized</b>	<b>De-energized</b>	<b>De-energized</b>
	Solenoid Feedback A/B	Not Available	Closed/Open	Open/Closed	Closed/Closed	Closed/Closed
	Safety A/B	Closed	Closed	Closed	Closed	Closed
Aux A (/B*)	Open	Open	Open	Open	Open	Open/Open
Step 2—Access to Hazardous Area Authorized 	<b>Solenoid Power</b>	<b>Energized</b>	<b>Energized</b>	<b>De-energized</b>	<b>Energized</b>	<b>Energized</b>
	Solenoid Feedback A/B	Not Available	Open/Closed	Closed/Open	Open/Open	Open/Open
	Safety A/B	Open *	Closed	Closed	Closed	Closed
Aux A (/B*)	Closed	Open	Open	Open	Open	Open/Closed
Step 3—Access Authorized AND Door Open 	<b>Solenoid Power</b>	<b>Energized</b>	<b>Energized</b>	<b>De-energized</b>	<b>Energized</b>	<b>Energized</b>
	Solenoid Feedback A/B	Not Available	Open/Closed	Closed/Open	Open/Open	Open/Open
	Safety A/B	Open	Open	Open	Open	Open
Aux A (/B*)	Closed	Closed	Closed	Closed	Closed	Open/Closed
Step 4—Gate Ready to Be Locked 	<b>Solenoid Power</b>	<b>De-energized</b>	<b>De-energized</b>	<b>Energized</b>	<b>De-energized</b>	<b>De-energized</b>
	Solenoid Feedback A/B	Not Available	Closed/Open	Open/Closed	Closed/Closed	Closed/Closed
	Safety A/B	Open	Open	Open	Open	Open
Aux A (/B*)	Closed	Closed	Closed	Closed	Closed	Closed/Open
Step 5—Door Locked and Hazardous Area Protected 	<b>Solenoid Power</b>	<b>De-energized</b>	<b>De-energized</b>	<b>Energized</b>	<b>De-energized</b>	<b>De-energized</b>
	Solenoid Feedback A/B	Not Available	Closed/Open	Open/Closed	Closed/Closed	Closed/Closed
	Safety A/B	Closed	Closed	Closed	Closed	Closed
Aux A (/B*)	Open	Open	Open	Open	Open	Open/Open

\* Direct drive of the contacts from the solenoid forces the safety contact to open even if the door is closed.  
 \* Aux B solenoid auxiliary contact is available only on the Atlas 5 safety switch.

3-Interlock Switches

## Safety Switches

### Guard Locking Switches

#### Overview

#### Application Example

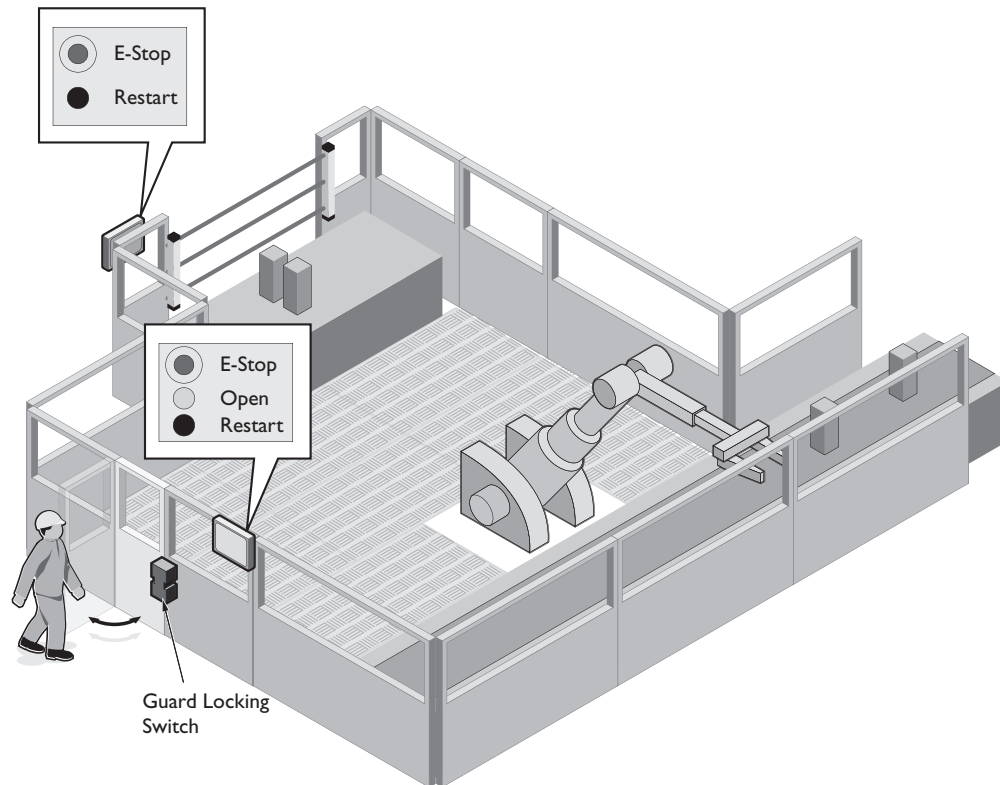

#### Operating Conditions

- The door is closed and locked with a 440G-MT safety switch.
- The robot is running.
- The GuardShield light curtain is muted when the robot is away from the assembly table.

#### Maintenance Conditions

- In order to clear the jam safely, the operator requests to unlock the door by activating the Open push button.
- The control system (MSR safety relay or SmartGuard 600) shuts down the robot and conveyor when the process conditions allow the robot and conveyor to be stopped without damaging the machine or the products (Controlled stop).
- When the robot and conveyor are stopped the control system allows the door to unlock by applying power to the solenoid in the 440G-MT safety switch.
- The maintenance person opens the door and clears the jam.
- When the task is done, the maintenance person exits the area, closes the door and activates the Restart push button.
- The control system restarts the robot and conveyor.

#### Remarks

- The safety mats are in place to avoid the machine restarting when the door is closed and the maintenance person is still in the hazardous area. Without the safety mats a Flexible Release can be mounted inside the hazardous area to unlock the door if this situation was to happen.
- The push of any E-Stop push buttons will stop the robot and the conveyor immediately (Immediate stop).

3-Interlock  
Switches

## Safety Switches

### Guard Locking Switches

#### 440G-MT



#### Description

The 440G-MT solenoid switch is a positive mode, tongue operated guard locking interlock switch that locks a machine guard closed until power is isolated while the guard is open. The guard may only be opened when a signal is applied to the internal solenoid which releases the lock mechanism. The 440G-MT locking mechanism is designed to withstand forces up to 1600 N (360 lb) and the die-cast alloy housing is ideal for use in harsh environments.

The 440G-MT solenoid switch is designed for machines that do not stop immediately or where premature interruption of the machine could cause damage to tooling and components or cause an additional hazard.

A 24V DC enhanced version is available with diagnostic output, which may be used by a control system to indicate whether a guard door is open or shut independently of the lock mechanism status. A built in LED further visually indicates the status of the switch as “door open,” “door shut and unlocked,” and “door shut and locked.”

This enhanced version is supplied with a metal manual override key to more easily enable manual unlocking in conditions when power is not available to electrically unlock the switch.

#### Features

- Mechanical lock
- High locking force—1600 N (360 lb)
- Heavy-duty die-cast alloy housing, ideal for harsh environments
- Diagnostic version available

#### Specifications

Safety Ratings						
Standards	EN954-1, ISO13849-1, IEC/EN60204-1, NFPA79, EN1088, ISO14119, IEC/EN60947-5-1, ANSI B11.19, AS4024.1					
Safety Classification	Cat. 1 Device per EN954-1 May be suitable for use in Cat 3 or Cat 4 systems depending on the architecture and application characteristics					
Functional Safety Data (related to Safety Contacts) *	B10d: > 2 x 10 <sup>6</sup> operations at min. load PFH <sub>D</sub> : < 3 x 10 <sup>-7</sup> MTTFd: > 385 years May be suitable for use in performance levels Plc or Pld systems (according to ISO 13849-1:2006) and for use in SIL2 or SIL3 systems (according to IEC 62061) depending on the architecture and application characteristics					
Certifications	CE Marked for all applicable directives, cULus, TÜV, and CCC					
Outputs						
Safety Contacts *	3 N.C. or 2 N.C. direct opening action					
Auxiliary Contacts	1 N.O. or 2 N.O.					
Thermal Current I <sub>th</sub>	10 A					
Rated Insulation Voltage	(Ui) 500V					
Switching Current @ Voltage, Min.	5 mA @ 5V DC					
Utilization Category						
A600/AC-15	(Ue)	600V	500V	240V	120V	
	(Ie)	1.2 A	1.4 A	3 A	6 A	
DC-13	(Ue)	24V				
	(Ie)	2 A				
Solenoid Characteristics						
Locking Type	Power to Release					
Holding Force, Max.	1600 N (360 lb)					
Power Supply	24V AC/DC or 110V AC or 230V AC					
Solenoid Power	13 W typical 100% ED					
Operating Characteristics						
Break Contact Force, Min.	6 N (1.35 lbf)					
Actuation Speed, Max.	160 mm (6.29 in.)/s					
Actuation Frequency, Max.	2 cycles/s					
Operating Radius, Min	60 mm (2.36 in.)					
Operating Life @ 100 mA load	1,000,000 operations					
Environmental						
Enclosure Type Rating	IP67					
Operating Temperature [C (F)]	-25...+60° (13...+140°)					
Physical Characteristics						
Housing Material	Painted zinc alloy					
Actuator Material	Stainless Steel					
Weight [g (lb)]	1400 (3.08)					
Color	Red					

\* Usable for ISO 13849-1:2006 and IEC 62061. Data is based on the B10d value given and:  
 - Usage rate of 1op/10 mins., 24 hrs/day, 360 days/year, representing 51840 operations per year  
 - Mission time/Proof test interval of 38 years

\* The safety contacts are described as normally closed (N.C.) i.e., with the guard closed, actuator in place (where relevant) and the machine able to be started.

## Safety Switches Guard Locking Switches 440G-MT

### Product Selection

Solenoid Voltage	Contact			Actuator Type	Cat. No.			
	Safety	Auxiliary	Action		M20 Conduit		Connector <sup>§</sup>	
					M20	1/2 inch NPT	12-Pin M23	8-Pin Micro (M12) <sup>‡</sup>
24V AC/DC	3 N.C.	1 N.O.	BBM	GD2 standard	<b>440G-MT47037</b>	440G-MT47039	440G-MT47041	440G-M3NBGDH-AC
				Fully-flexible	440G-MT47038	440G-MT47040	440G-MT47042	440G-M3NBBDH-AC
				—	440G-MT47007	440G-MT47008	<b>440G-MT47043</b>	—
	2 N.C.	2 N.O.	BBM	GD2 standard	440G-MT47044	440G-MT47046	440G-MT47048	—
				Fully-flexible	440G-MT47045	440G-MT47047	440G-MT47049	—
				—	440G-MT47010	440G-MT47011	440G-MT47050	—
24V DC with diagnostic function and metal override key	3 N.C.	1 N.O.	BBM	GD2 standard	440G-MT47149	440G-MT47150	440G-MT47151	—
				Fully flexible	440G-MT47152	440G-MT47153	440G-MT47154	—
				No actuator	440G-MT47155	440G-MT47156	440G-MT47157	—
	2 N.C.	2 N.O.	BBM	GD2 standard	440G-MT47158	440G-MT47159	440G-MT47160	—
				Fully flexible	440G-MT47161	440G-MT47162	440G-MT47163	—
				No actuator	440G-MT47164	440G-MT47165	440G-MT47166	—
110V AC/DC	3 N.C.	1 N.O.	BBM	GD2 standard	440G-MT47070	440G-MT47073	—	—
				Fully-flexible	440G-MT47071	440G-MT47074	—	—
				—	440G-MT47013	440G-MT47009	—	—
	2 N.C.	2 N.O.	BBM	GD2 standard	440G-MT47077	440G-MT47079	—	—
				Fully-flexible	440G-MT47078	440G-MT47080	—	—
				—	440G-MT47012	440G-MT47014	—	—
230V AC/DC	3 N.C.	1 N.O.	BBM	—	440G-MT47016	440G-MT47017	—	—
	2 N.C.	2 N.O.		—	440G-MT47015	440G-MT47024	—	—

§ For connector ratings see page 3-9.

‡ With an 8-pin micro (M12) connector, not all contacts are connected. See page 3-39 for wiring details.

### Recommended Logic Interfaces

Description	Safety Outputs	Auxiliary Outputs	Time Delay	Terminals	Reset Type	Power Supply	Cat. Page No.	Cat. No.
<b>Single-Function Safety Relays</b>								
MSR127RP	3 N.O.	1 N.C.	—	Removable (Screw)	Monitored Manual	24V AC/DC	5-26	<b>440R-N23135</b>
MSR127TP	3 N.O.	1 N.C.	—	Removable (Screw)	Auto./Manual	24V AC/DC	5-26	<b>440R-N23132</b>
MSR126T	2 N.O.	None	—	Fixed	Auto./Manual	24V AC/DC	5-24	<b>440R-N23117</b>
MSR30RT	2 N.O. Solid State	1 N.O. Solid State	—	Removable	Auto./Manual or Monitored Manual	24V DC	5-16	440R-N23198
<b>Specialty Safety Relays</b>								
MSR178	3 N.O.	2 N.C.	0.5 s...30 min	Removable	Automatic	24V AC/DC, 115V AC or 230V AC	5-40	440R-M23227
CU2	2 N.O.	1 N.C.	0.1 s...40 min	Fixed	—	24V AC/DC	5-56	440R-S07281
CU3	2 N.O.	1 N.C.	—	Fixed	Automatic/Manual	110V AC	5-64	440R-S35002
<b>Modular Safety Relays</b>								
MSR210P Base 2 N.C. only	2 N.O.	1 N.C. and 2 PNP Solid State	—	Removable	Auto./Manual or Monitored Manual	24V DC from the base unit	5-82	440R-H23176
MSR220P Input Module	—	—	—	Removable	—	24V DC	5-86	440R-H23178
MSR310P Base	MSR300 Series Output Modules	3 PNP Solid State	—	Removable	Auto./Manual Monitored Manual	24V DC	5-102	440R-W23219
MSR320P Input Module	—	2 PNP Solid State	—	Removable	—	24V DC from the base unit	5-106	440R-W23218

**Note:** For additional Safety Relays connectivity, see page 5-12.  
For additional Safety I/O and Safety PLC connectivity, see page 5-116.  
For application and wiring diagrams, see page 10-1.

**3-Interlock Switches**

# Safety Switches

## Guard Locking Switches









### 440G-MT

#### Connection Systems

Description	8-Pin Micro	12-Pin M23
Cordset	889D-F8AB-*	889M-F12AH-*
Patchcord	889D-F8ABDM-*	889M-F12AHMU-†

\* Replace symbol with 2 (2 m), 5 (5 m), or 10 (10 m) for standard cable lengths.  
 \* Replace symbol with 1 (1 m), 2 (2 m), 3 (3 m), 5 (5 m), or 10 (10 m) for standard cable lengths.  
 † Replace symbol with 0M3, (0.3 m), 0M6 (0.6 m), 1 (1 m), 2 (2 m) or 3 (3 m) for standard lengths.  
**Note:** For additional information, see page 7-1.

#### Accessories

Description	Dimensions	Cat. No.
 GD2 standard actuator	3-50	<b>440G-A27011</b>
 GD2 flat actuator		<b>440K-A11112</b>
 Fully flex actuator		<b>440G-A27143</b>
 Sliding bolt actuator		440G-A27163
 Extended flat actuator		<b>440K-A17116</b>
 Replacement Cover, No LED, No Override Key	—	440G-MT47120
 Replacement Cover, LED, Override Key	—	440G-MT47123
 Emergency Override Key (See Warning below.)	—	440G-A36026
 Dust Cover	—	440K-A17180

3-Interlock Switches



**WARNING:** Do not attach the Emergency Override Key to the 440G-MT switch.

#### Approximate Dimensions

Dimensions are shown in mm (in.). Dimensions are not intended to be used for installation purposes.

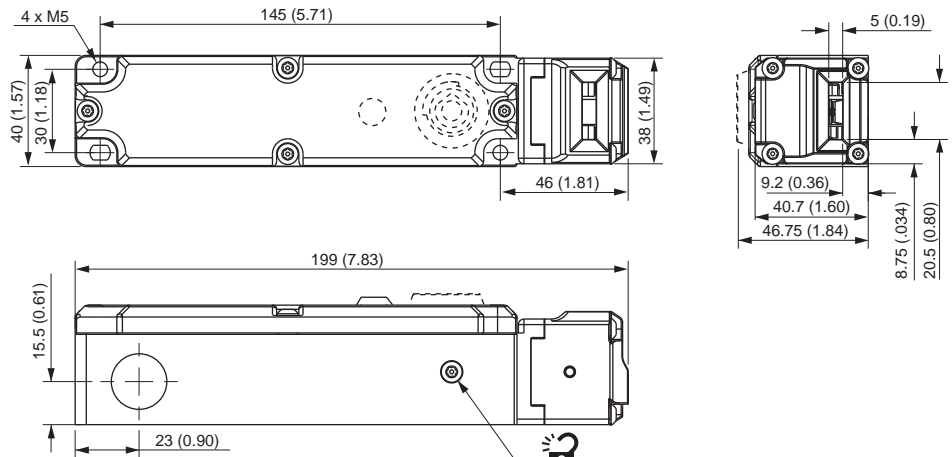

**Note:** 2D, 3D and electrical drawings are available on [www.ab.com](http://www.ab.com).

## Safety Switches Guard Locking Switches 440G-MT

### Typical Wiring Diagrams

	2 N.C. & 2 N.O.	3 N.C. & 1 N.O.																																															
Contact Configuration																																																	
Contact Action																																																	
□ Open ■ Closed	BBM	BBM																																															
8-Pin Micro (M12)	—																																																
12-Pin M23 QD	<p>Pin 11 not connected.</p>	<table border="1" style="width: 100%; border-collapse: collapse;"> <tr><td>1 and 3</td><td>Solenoid Power</td><td>Solenoid Power</td></tr> <tr><td>4 and 6</td><td>Safety A</td><td>Safety A</td></tr> <tr><td>7 and 8</td><td>Safety B</td><td>Safety B</td></tr> <tr><td>2 and 5</td><td>Aux A</td><td>Safety C</td></tr> <tr><td>9 and 10</td><td>Aux B</td><td>Aux A</td></tr> <tr><td>12</td><td>Ground</td><td>Ground</td></tr> </table>	1 and 3	Solenoid Power	Solenoid Power	4 and 6	Safety A	Safety A	7 and 8	Safety B	Safety B	2 and 5	Aux A	Safety C	9 and 10	Aux B	Aux A	12	Ground	Ground																													
1 and 3	Solenoid Power	Solenoid Power																																															
4 and 6	Safety A	Safety A																																															
7 and 8	Safety B	Safety B																																															
2 and 5	Aux A	Safety C																																															
9 and 10	Aux B	Aux A																																															
12	Ground	Ground																																															
8-Pin Cordset 889D-F8AB-*	<table border="1" style="width: 100%; border-collapse: collapse;"> <tr><td>Brown</td><td>—</td><td>Solenoid Power</td></tr> <tr><td>Blue</td><td>—</td><td>Safety A</td></tr> <tr><td>Grey</td><td>—</td><td>Safety B</td></tr> <tr><td>Red</td><td>—</td><td>Aux A</td></tr> <tr><td>Yellow</td><td>—</td><td>—</td></tr> <tr><td>Pink</td><td>—</td><td>—</td></tr> <tr><td>White</td><td>—</td><td>—</td></tr> <tr><td>Green</td><td>—</td><td>—</td></tr> </table>	Brown	—	Solenoid Power	Blue	—	Safety A	Grey	—	Safety B	Red	—	Aux A	Yellow	—	—	Pink	—	—	White	—	—	Green	—	—	<table border="1" style="width: 100%; border-collapse: collapse;"> <tr><td>—</td><td>Solenoid Power</td></tr> <tr><td>—</td><td>Safety A</td></tr> <tr><td>—</td><td>Safety B</td></tr> <tr><td>—</td><td>Aux A</td></tr> </table>	—	Solenoid Power	—	Safety A	—	Safety B	—	Aux A															
Brown	—	Solenoid Power																																															
Blue	—	Safety A																																															
Grey	—	Safety B																																															
Red	—	Aux A																																															
Yellow	—	—																																															
Pink	—	—																																															
White	—	—																																															
Green	—	—																																															
—	Solenoid Power																																																
—	Safety A																																																
—	Safety B																																																
—	Aux A																																																
12-Pin Cordset 889M-F12AH-*	<table border="1" style="width: 100%; border-collapse: collapse;"> <tr><td>Brown</td><td>Solenoid Power</td><td>Solenoid Power</td></tr> <tr><td>Grey</td><td>Safety A</td><td>Safety A</td></tr> <tr><td>Pink</td><td>Safety B</td><td>Safety B</td></tr> <tr><td>Yellow</td><td>Safety B</td><td>Safety B</td></tr> <tr><td>White</td><td>Safety A</td><td>Safety A</td></tr> <tr><td>Red/Blue</td><td>Safety B</td><td>Safety B</td></tr> <tr><td>Blue</td><td>Aux A</td><td>Safety C</td></tr> <tr><td>Red</td><td>Aux A</td><td>Safety C</td></tr> <tr><td>Black</td><td>Aux B</td><td>Aux A</td></tr> <tr><td>Violet</td><td>Aux B</td><td>Aux A</td></tr> <tr><td>Green</td><td>Ground</td><td>Ground</td></tr> </table>	Brown	Solenoid Power	Solenoid Power	Grey	Safety A	Safety A	Pink	Safety B	Safety B	Yellow	Safety B	Safety B	White	Safety A	Safety A	Red/Blue	Safety B	Safety B	Blue	Aux A	Safety C	Red	Aux A	Safety C	Black	Aux B	Aux A	Violet	Aux B	Aux A	Green	Ground	Ground	<table border="1" style="width: 100%; border-collapse: collapse;"> <tr><td>—</td><td>Solenoid Power</td></tr> <tr><td>—</td><td>Safety A</td></tr> <tr><td>—</td><td>Safety B</td></tr> <tr><td>—</td><td>Safety C</td></tr> <tr><td>—</td><td>Aux A</td></tr> <tr><td>—</td><td>Aux A</td></tr> <tr><td>—</td><td>Ground</td></tr> </table>	—	Solenoid Power	—	Safety A	—	Safety B	—	Safety C	—	Aux A	—	Aux A	—	Ground
Brown	Solenoid Power	Solenoid Power																																															
Grey	Safety A	Safety A																																															
Pink	Safety B	Safety B																																															
Yellow	Safety B	Safety B																																															
White	Safety A	Safety A																																															
Red/Blue	Safety B	Safety B																																															
Blue	Aux A	Safety C																																															
Red	Aux A	Safety C																																															
Black	Aux B	Aux A																																															
Violet	Aux B	Aux A																																															
Green	Ground	Ground																																															
—	Solenoid Power																																																
—	Safety A																																																
—	Safety B																																																
—	Safety C																																																
—	Aux A																																																
—	Aux A																																																
—	Ground																																																

\* Replace symbol with 2 (2 m), 5 (5 m) or 10 (10 m) for standard cable lengths.

#### Diagnostic Version

Actuator	LED Output Matrix	
	Solenoid Off	Solenoid On
In	Green	Amber
Out	Flashing Red	Red

#### Diagnostic Electrical Output

Actuator	Voltage
In	0V DC
Out	+24V DC

Electrical output independent of solenoid status. Maximum output is 100 mA.

**3-Interlock  
Switches**

## Safety Switches

# Guard Locking Switches

### TLS-GD2



#### Description

The TLS-GD2 is a positive mode, tongue operated guard locking interlock switch that locks a machine guard closed until power is isolated and ensures that it remains isolated while the guard is open. It has three safety (N.C.) contacts and two auxiliary (N.O.) contacts. The TLS-GD2 head has two entry slots and it can be rotated to provide four actuator entry points. A blanking plug is provided to seat the unused slot.

The guard may only be opened when a signal is applied to the TLS-GD2's internal solenoid which releases the lock mechanism. This signal can be via CU1 electronic timer relays or CU2 stopped motion detectors. Therefore the TLS-GD2 is ideal for machines which do not stop immediately or where premature interruption of the machine could cause damage to tooling and components or cause an additional hazard.

The TLS-GD2 is available in three types. The TLS-1 GD2 and TLS-3 GD2 incorporate a power-to-release function. Two manual release points with security screws allow the locked TLS-GD2 to be released in emergencies. An optional lid-mounted key-release style can also be supplied. The TLS-2 GD2 has a power-to-lock function. Each type of switch has five sets of contacts of various forms and are suitable for use with PLCs.

The TLS-1 GD2 and TLS-3 GD2 are both available with escape release options. They are intended for machine guarding with full body access. The switch is installed so that the escape release push button on the rear side is accessible from inside the hazardous area. This allows the intentional unlocking of the TLS-GD2 from inside a hazardous area, providing a means of escape for a person who may become trapped.

A stainless-steel actuator guide is fitted to protect the unit from actuator damage due to poor guard alignment or guard wear.

TLS-GD2 has an ingress protection rating of IP69K making it suitable for harsh washdown applications as found in the food and beverage, pharmaceutical, solar and semiconductor industries.



**IMPORTANT:** With the TLS-2 GD2 "power to lock" style, provisions may be required to ensure that a dangerous situation can not result from open circuit faults or power cuts.

#### Features

- Power to release or power to lock
- High locking force  $\leq 2000$  N (450 lb)
- Five contacts: 2 N.C. & 1 N.O. for door position monitoring 1 N.C. & 1 N.O. or 2 N.C. for lock monitoring
- Rotatable head: 4 possible key entry slots
- Conforms to EN 1088 & EN 60947-5-1
- Escape Release version available
- IP69K, suitable for high pressure, high temperature washdown

#### Specifications

Safety Ratings					
Standards	EN954-1, ISO13849-1, IEC/EN60204-1, NFPA79, EN1088, ISO14119, IEC/EN60947-5-1, ANSI B11.19, AS4024.1				
Safety Classification	Cat. 1 device per EN 954-1 dual channel interlocks suitable for Cat. 3 or 4 systems				
Functional Safety Data (related to Safety Contacts) *	B10d: $> 2 \times 10^6$ operations at min. load PFH <sub>D</sub> : $< 3 \times 10^{-7}$ MTTFd: $> 385$ years May be suitable for use in performance levels Ple or Pld systems (according to ISO 13849-1:2006) and for use in SIL2 or SIL3 systems (according to IEC 62061) depending on the architecture and application characteristics				
Certifications	CE Marked for all applicable directives, cULus, TÜV, and CCC				
Outputs					
Safety Contacts *	(TLS-1 & -2) 3 N.C. direct opening action (TLS-3) 4 N.C. direct opening action				
Auxiliary Contacts	(TLS-1 & -2) 2 N.O. (1 solenoid monitoring) (TLS-3 1 N.O.)				
Thermal Current <sub>I<sub>th</sub></sub>	10 A				
Rated Insulation Voltage	(Ui) 500V				
Switching Current @ Voltage, Min.	5 mA @ 5V DC				
Utilization Category					
A600/AC-15	(Ue)	600V	500V	240V	120V
	(Ie)	1.2 A	1.4 A	3.0 A	6.0 A
DC-13	(Ue)	24V			
	(Ie)	2 A			
Solenoid Characteristics					
Locking Type	TLS-1 & -3 Power-to-Release TLS-2 Power-to-Lock				
Holding Force, Max.	2000 N (450 lbf)				
Releasable Load, Max.	100 N (22.5 lbf)				
Power Supply	24V AC/DC or 110V AC or 230V AC (solenoid)				
Solenoid Power	Typically 7 W 100% ED				
Escape Release Button	Force max.: 50 N (11.25 lbs)				
Operating Characteristics					
Break Contact Force, Min.	20 N (4.5 lbf)				
Actuation Speed, Max.	160 mm (6.29 in.)/s				
Actuation Frequency, Max.	1 cycle/s				
Operating Radius, Min	160 mm (6.3 in.) [80 mm (3.15 in.) with flexible actuator]				
Operating Life @ 100 mA load	1,000,000 operations				
Environmental					
Enclosure Type Rating	IP66, IP67 and IP69K				
Operating Temperature [C (F)]	-20...+60° (-4...+140°)				
Physical Characteristics					
Housing Material	UL Approved glass-filled PBT				
Actuator Material	Stainless Steel				
Weight [g (lb)]	400 (0.88)				
Color	Red				

\* Usable for ISO 13849-1:2006 and IEC 62061. Data is based on the B10d value given and:  
- Usage rate of 1op/10mins., 24hrs/day, 360 days/year, representing 51840 operations per year  
- Mission time/Proof test interval of 38 years

\* The safety contacts are described as normally closed (N.C.) i.e., with the guard closed, actuator in place (where relevant) and the machine able to be started.



Safety Switches  
**Guard Locking Switches**  
 TLS-GD2



**Product Selection**

Type	Contacts		Solenoid		Actuator Type	Cat. No.			
	Safety	Auxiliary	Contacts	Voltage		Conduit		Connector§	
						M20	1/2 inch NPT Adaptor	12-Pin M23	8-Pin Micro (M12)*
TLS-1 GD2 Power to Release	2 N.C.	1 N.O.	1 N.C. & 1 N.O.	24V AC/DC	—	<b>440G-T27121</b>	—	440G-T27233	440G-T2NBBPH-1R
					GD2 Standard	440G-T27251	440G-T27169	440G-T27234	—
					Fully Flex	440G-T27252	<b>440G-T27171</b>	440G-T27235	—
				110V AC/DC	—	440G-T27124	—	—	—
					GD2 Standard	440G-T27253	440G-T27172	—	—
					Fully Flex	440G-T27254	440G-T27174	—	—
230V AC/DC	—	440G-T27123	—	—	—				
TLS-2 GD2 Power to Lock	2 N.C.	1 N.O.	1 N.C. & 1 N.O.	24V AC/DC	—	<b>440G-T27127</b>	—	440G-T27239	440G-T2NBBPH-1L
					GD2 Standard	440G-T27255	440G-T27175	440G-T27240	—
					Fully Flex	440G-T27256	<b>440G-T27177</b>	440G-T27241	—
				110V AC/DC	—	440G-T27132	—	—	—
					GD2 Standard	440G-T27257	440G-T27178	—	—
					Fully Flex	440G-T27258	440G-T27180	—	—
230V AC/DC	—	440G-T27129	—	—	—				
TLS-3 GD2 Power to Release	2 N.C.	1 N.O.	2 N.C.	24V AC/DC	—	<b>440G-T27134</b>	—	440G-T27245	440G-T2NBBPH-2R
					GD2 Standard	440G-T27259	440G-T27181	440G-T27246	—
					Fully Flex	440G-T27260	440G-T27183	440G-T27247	—
				110V AC/DC	—	440G-T27138	—	—	—
					GD2 Standard	440G-T27261	440G-T27184	—	—
					Fully Flex	440G-T27262	440G-T27186	—	—
230V AC/DC	—	440G-T27136	—	—	—				
TLS-1 GD2 Power to Release with Escape Release	2 N.C.	1 N.O.	1 N.C. & 1 N.O.	24V AC/DC	—	440G-T21BNPM-1B	440G-T21BNPT-1B	440G-T21BNPL-1B	440G-T2NBNPH-1B
					GD2 Standard	440G-T21BGPM-1B	440G-T21BGPT-1B	440G-T21BGPL-1B	—
					Fully Flex	440G-T21BNPM-4B	440G-T21BNPT-4B	—	—
				110V AC/DC	—	440G-T21BNPM-4B	440G-T21BGPT-4B	—	—
					GD2 Standard	440G-T21BGPM-4B	440G-T21BGPT-4B	—	—
					Fully Flex	440G-T21BNPM-2B	440G-T21BNPT-2B	440G-T21BNPL-2B	440G-T2NBNPH-2B
24V AC/DC	—	440G-T21BNPM-2B	440G-T21BGPT-2B	440G-T21BGPL-2B	—				
	GD2 Standard	440G-T21BGPM-2B	440G-T21BGPT-2B	440G-T21BGPL-2B	—				
	Fully Flex	440G-T21BNPM-5B	440G-T21BNPT-5B	—	—				
110V AC/DC	—	440G-T21BNPM-5B	440G-T21BGPT-5B	—	—				
	GD2 Standard	440G-T21BGPM-5B	440G-T21BGPT-5B	—	—				
	Fully Flex	440G-T21BNPM-5B	440G-T21BGPT-5B	—	—				

**3-Interlock Switches**

§ For connector ratings, see page 3-9.

\* With an 8-pin micro connector, not all contacts are connected. See page 3-45 for wiring details.

	<p><b>WARNING:</b> To monitor <b>independently</b> the safety contact(s) and the solenoid feedback (TLS 1, 2 and 3):</p> <ul style="list-style-type: none"> <li>• The 12-wire cordset 889M-F12AH-* must be used</li> </ul> <p>AND</p> <ul style="list-style-type: none"> <li>• For the TLS1 and TLS2: the jumper between 12 and 41 must be removed</li> <li>• For the TLS3: the jumpers between 12 and 41 and 22 and 51 must be removed</li> </ul>
	<p>Monitoring of safety contact(s) and the solenoid feedback (in series) is available, when jumpers are in place:</p> <p>AND</p> <ul style="list-style-type: none"> <li>• For the TLS1 and TLS2: by using pins 4 and 6 on the 12-pin, M23 receptacle or Pink and Yellow wires on the 12-wire cordset (889M-F12AH-*)</li> <li>• For the TLS3: by using pins 4 and 6 and pins 7 and 8 on the 12-pin, M23 receptacle or Pink and Yellow and White and Red/Blue wires on the 12-wire cordset (889M-F12AH-*)</li> </ul>

\* Replace symbol with 2 (2 m), 5 (5 m), or 10 (10 m) for standard cable lengths.

## Safety Switches

### Guard Locking Switches

#### TLS-GD2

#### Recommended Logic Interfaces

Description	Safety Outputs	Auxiliary Outputs	Time Delay	Terminals	Reset Type	Power Supply	Cat. Page No.	Cat. No.
<b>Single-Function Safety Relays</b>								
MSR127RP	3 N.O.	1 N.C.	—	Removable (Screw)	Monitored Manual	24V AC/DC	5-26	440R-N23135
MSR127TP	3 N.O.	1 N.C.	—	Removable (Screw)	Auto./Manual	24V AC/DC	5-26	440R-N23132
MSR126T	2 N.O.	None	—	Fixed	Auto./Manual	24V AC/DC	5-24	440R-N23117
MSR30RT	2 N.O. Solid State	1 N.O. Solid State	—	Removable	Auto./Manual or Monitored Manual	24V DC	5-16	440R-N23198
<b>Specialty Safety Relays</b>								
MSR178	3 N.O.	2 N.C.	0.5 s...30 min	Removable	Automatic	24V AC/DC, 115V AC or 230V AC	5-40	440R-M23227
CU2	2 N.O.	1 N.C.	0.1 s...40 min	Fixed	—	24V AC/DC	5-56	440R-S07281
CU3	2 N.O.	1 N.C.	—	Fixed	Automatic/Manual	110V AC	5-64	440R-S35002
<b>Modular Safety Relays</b>								
MSR210P Base 2 N.C. only	2 N.O.	1 N.C. and 2 PNP Solid State	—	Removable	Auto./Manual or Monitored Manual	24V DC from the base unit	5-82	440R-H23176
MSR220P Input Module	—	—	—	Removable	—	24V DC	5-86	440R-H23178
MSR310P Base	MSR300 Series Output Modules	3 PNP Solid State	—	Removable	Auto./Manual Monitored Manual	24V DC	5-102	440R-W23219
MSR320P Input Module	—	2 PNP Solid State	—	Removable	—	24V DC from the base unit	5-106	440R-W23218

**Note:** For additional Safety Relays connectivity, see page 5-12.  
For additional Safety I/O and Safety PLC connectivity, see page 5-116.  
For application and wiring diagrams, see page 10-1.

#### Connection Systems

Description	8-Pin Micro (M12)	12-Wire, 12-Pin M23	9-Wire, 12-Pin M23§
Cordset	889D-F8AB-*	889M-F12AH-*	889M-FX9AE-*
Patchcord	889D-F8ABDM-*	889M-F12AHMU-‡	—

\* Replace symbol with 2 (2 m), 5 (5 m), or 10 (10 m) for standard cable lengths.  
\* Replace symbol with 1 (1 m), 2 (2 m), 3 (3 m), 5 (5 m), or 10 (10 m) for standard cable lengths.  
‡ Replace symbol with 0M3, (0.3 m), 0M6 (0.6 m), 1 (1 m), 2 (2 m) or 3 (3 m) for standard lengths.  
§ The 9-wire cordset can be used only with the TLS3 versions.

**Note:** For additional information, see page 7-1.











3-Interlock  
Switches

## Safety Switches

# Guard Locking Switches

### TLS-GD2

#### Accessories

	Description	Dimensions	Cat. No.
	GD2 standard actuator	3-50	440G-A27011
	GD2 flat actuator	3-51	440K-A11112
	Extended flat actuator	3-51	440K-A17116
	Fully flex actuator	3-50	440G-A27143
	Sliding bolt actuator not to be used with the Escape Release	3-55	440G-A27163
	Cover for TLS-1 with external override key for series D and earlier	—	440G-A27140
	Cover for TLS-3 with external override key for series D and earlier		440G-A27142
	Cover for TLS-1 with override key attached for series D and earlier		440G-A27207
	Cover for TLS-3 with override key attached for series D and earlier		440G-A27208
	Cover for TLS-1 with external override key for series E and later		440G-A27371
	Cover for TLS-3 with external override key for series E and later		440G-A27372
	Cover for TLS-1 with override key attached for series E and later		440G-A27373
	Cover for TLS-3 with override key attached for series E and later		440G-A27374
	Emergency Override Key (See Warning below.)	—	440G-A36026
	Flexible Release—1 m (3.28 ft) Cable	3-54	440G-A27356
	Flexible Release—3 m (9.84 ft) Cable		440G-A27357
	Dust Cover	—	440K-A17183
	Sliding Bolt	3-55	440K-AMDS
	Mounting Plate	3-55	440K-AMDSSMPB

**3-Interlock  
Switches**

**WARNING:** Do not attach the Emergency Override Key to the TLS-GD2 switch.

# Safety Switches

## Guard Locking Switches

### TLS-GD2

#### Approximate Dimensions

Dimensions are shown in mm (in.). Dimensions are not intended to be used for installation purposes.

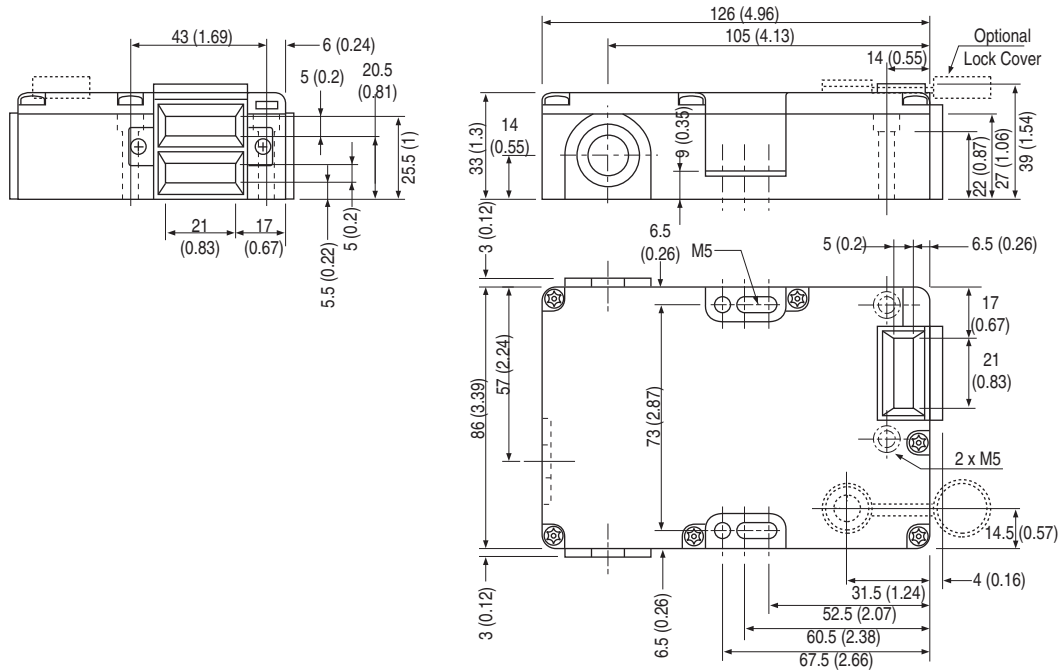

#### TLS-GD2 Escape Release

3-Interlock Switches

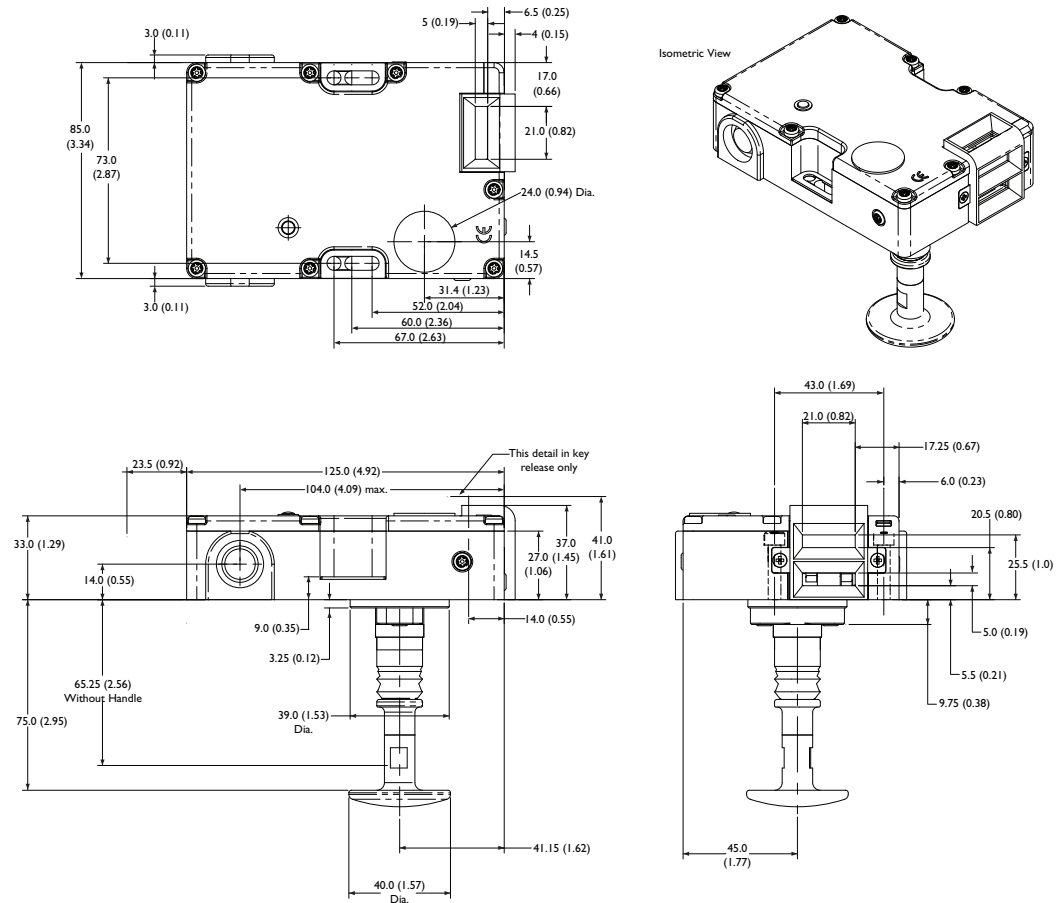

**Note:** 2D, 3D and electrical drawings are available on [www.ab.com](http://www.ab.com).

## Safety Switches Guard Locking Switches TLS-GD2

### Typical Wiring Diagrams

Red Switches	TLS1	TLS2	TLS3																								
Contact Configuration	<p style="text-align: center;">Jumper between 12 &amp; 41</p>		<p style="text-align: center;">Jumper between 12 &amp; 41 and 22 &amp; 51</p>																								
Contact Action	<p style="text-align: center;">BBM</p>	<p style="text-align: center;">BBM</p>	<p style="text-align: center;">BBM</p>																								
8-Pin Micro (M12)	<p style="text-align: center;">No jumper on 12-41.</p>		<p style="text-align: center;">Jumper on 12-41 and 22-51.</p>																								
12-Pin M23		<table border="1" style="width: 100%; border-collapse: collapse;"> <tr><td>1 and 3</td><td>Solenoid Power</td></tr> <tr><td>4 and 12</td><td>Safety A ❖</td></tr> <tr><td>7 and 8</td><td>Safety B</td></tr> <tr><td>9 and 10</td><td>Aux A</td></tr> <tr><td>6 and 11</td><td>Solenoid A ❖</td></tr> <tr><td>2 and 5</td><td>Solenoid B</td></tr> </table>	1 and 3	Solenoid Power	4 and 12	Safety A ❖	7 and 8	Safety B	9 and 10	Aux A	6 and 11	Solenoid A ❖	2 and 5	Solenoid B	<table border="1" style="width: 100%; border-collapse: collapse;"> <tr><td>1 and 3</td><td>Solenoid Power</td></tr> <tr><td>4 and 12</td><td>Safety A ❖</td></tr> <tr><td>7 and 5</td><td>Safety B ❖</td></tr> <tr><td>9 and 10</td><td>Aux A</td></tr> <tr><td>6 and 11</td><td>Solenoid A ❖</td></tr> <tr><td>2 and 8</td><td>Solenoid B ❖</td></tr> </table>	1 and 3	Solenoid Power	4 and 12	Safety A ❖	7 and 5	Safety B ❖	9 and 10	Aux A	6 and 11	Solenoid A ❖	2 and 8	Solenoid B ❖
1 and 3	Solenoid Power																										
4 and 12	Safety A ❖																										
7 and 8	Safety B																										
9 and 10	Aux A																										
6 and 11	Solenoid A ❖																										
2 and 5	Solenoid B																										
1 and 3	Solenoid Power																										
4 and 12	Safety A ❖																										
7 and 5	Safety B ❖																										
9 and 10	Aux A																										
6 and 11	Solenoid A ❖																										
2 and 8	Solenoid B ❖																										
8-Pin Cordset 889D-F8AB-*	<table border="1" style="width: 100%; border-collapse: collapse;"> <tr><td>Brown Blue</td><td>Solenoid Power</td></tr> <tr><td>Grey Red</td><td>Safety A</td></tr> <tr><td>Yellow Pink</td><td>Safety B</td></tr> <tr><td>White Green</td><td>Solenoid A</td></tr> </table>	Brown Blue	Solenoid Power	Grey Red	Safety A	Yellow Pink	Safety B	White Green	Solenoid A	<table border="1" style="width: 100%; border-collapse: collapse;"> <tr><td>Solenoid Power</td></tr> <tr><td>Safety A &amp; Solenoid A</td></tr> <tr><td>Safety B &amp; Solenoid B</td></tr> <tr><td>Solenoid A</td></tr> </table>	Solenoid Power	Safety A & Solenoid A	Safety B & Solenoid B	Solenoid A													
Brown Blue	Solenoid Power																										
Grey Red	Safety A																										
Yellow Pink	Safety B																										
White Green	Solenoid A																										
Solenoid Power																											
Safety A & Solenoid A																											
Safety B & Solenoid B																											
Solenoid A																											
12-Pin, 9-Wire Cordset 889M-FX9AE-*	Can not be used.		<table border="1" style="width: 100%; border-collapse: collapse;"> <tr><td>Brown Blue</td><td>Solenoid Power</td></tr> <tr><td>White Green</td><td>Safety A &amp; Solenoid A</td></tr> <tr><td>Yellow Grey</td><td>Safety B &amp; Solenoid B</td></tr> <tr><td>Pink Red</td><td>Aux A</td></tr> </table>	Brown Blue	Solenoid Power	White Green	Safety A & Solenoid A	Yellow Grey	Safety B & Solenoid B	Pink Red	Aux A																
Brown Blue	Solenoid Power																										
White Green	Safety A & Solenoid A																										
Yellow Grey	Safety B & Solenoid B																										
Pink Red	Aux A																										
12-Pin, 12-Wire Cordset 889M-F12AH-*	<table border="1" style="width: 100%; border-collapse: collapse;"> <tr><td>Brown Grey</td><td>Solenoid Power</td></tr> <tr><td>Pink Green</td><td>Safety A ❖</td></tr> <tr><td>White Red/Blue</td><td>Safety B</td></tr> <tr><td>Black Violet</td><td>Aux A</td></tr> <tr><td>Grey/Pink Yellow</td><td>Solenoid A ❖</td></tr> <tr><td>Blue Red</td><td>Solenoid B</td></tr> </table>	Brown Grey	Solenoid Power	Pink Green	Safety A ❖	White Red/Blue	Safety B	Black Violet	Aux A	Grey/Pink Yellow	Solenoid A ❖	Blue Red	Solenoid B	<table border="1" style="width: 100%; border-collapse: collapse;"> <tr><td>Brown Grey</td><td>Solenoid Power</td></tr> <tr><td>Pink Green</td><td>Safety A ❖</td></tr> <tr><td>White Red</td><td>Safety B ❖</td></tr> <tr><td>Black Violet</td><td>Aux A</td></tr> <tr><td>Grey/Pink Yellow</td><td>Solenoid A ❖</td></tr> <tr><td>Blue Red/Blue</td><td>Solenoid B ❖</td></tr> </table>	Brown Grey	Solenoid Power	Pink Green	Safety A ❖	White Red	Safety B ❖	Black Violet	Aux A	Grey/Pink Yellow	Solenoid A ❖	Blue Red/Blue	Solenoid B ❖	
Brown Grey	Solenoid Power																										
Pink Green	Safety A ❖																										
White Red/Blue	Safety B																										
Black Violet	Aux A																										
Grey/Pink Yellow	Solenoid A ❖																										
Blue Red	Solenoid B																										
Brown Grey	Solenoid Power																										
Pink Green	Safety A ❖																										
White Red	Safety B ❖																										
Black Violet	Aux A																										
Grey/Pink Yellow	Solenoid A ❖																										
Blue Red/Blue	Solenoid B ❖																										

\* Replace symbol with 2 (2 m), 5 (5 m) or 10 (10 m) for standard cable lengths.  
❖ See **WARNING** notes on page 3-41.

**3-Interlock Switches**

## Safety Switches

# Guard Locking Switches

### Atlas™ 5



#### Description

The Atlas 5 is a positive-mode, tongue-operated guard-locking interlock switch that locks a machine guard closed until power is isolated to ensure that it remains isolated while the guard is open. A heavy-duty switch, the Atlas 5 locking mechanism is designed to withstand forces up to 5000 N (1124 lb) and the die-cast alloy housing is ideal for use in harsh environments. A unique feature of the Atlas 5 is a patented self-aligning head that tolerates actuator or guard misalignment, making it particularly useful for heavy machine guards.

The Atlas 5 is designed for machines that do not stop immediately or where premature interruption of the machine could cause damage to tooling and components or cause an additional hazard. With 2 safety (N.C.) contacts and 2 auxiliary (N.O.) contact, Atlas 5 is ideal for PLC controlled machines.

#### Features

- Mechanical lock
- High locking force—5000 N (1124 lb)
- Heavy duty die-cast alloy housing ideal for harsh environments
- Patented self-aligning head tolerates actuator misalignment

3-Interlock Switches

#### Specifications

Safety Ratings	
Standards	EN954-1, ISO13849-1, IEC/EN60204-1, NFPA79, EN1088, ISO14119, IEC/EN60947-5-1, ANSI B11.19, AS4024.1
Safety Classification	Cat. 1 Device per EN954-1 Dual channel interlocks suitable for Cat. 3 or 4 systems
Functional Safety Data (related to Safety Contacts) *	B10d: > 2 x 10 <sup>6</sup> operations at min. load PFH <sub>D</sub> : < 3 x 10 <sup>-7</sup> MTTFd: > 385 years May be suitable for use in performance levels Ple or Pld systems (according to ISO 13849-1:2006) and for use in SIL2 or SIL3 systems (according to IEC 62061) depending on the architecture and application characteristics
Certifications	CE Marked for all applicable directives, cULus, CSA, and TÜV
Outputs	
Safety Contacts *	Atlas 5: 2 N.C. direct opening action; 1 N.O. direct opening action Atlas 5 trapped key (left hand): 2 N.C. direct opening action; 1 N.O. direct opening action
Auxiliary Contacts	1 N.O.
Thermal Current <i>I<sub>th</sub></i>	10 A
Rated Insulation Voltage	(U <sub>i</sub> ) 500V
Switching Current @ Voltage, Min.	5 mA @ 5V DC
Utilization Category	
AC-15	(Ue) 240V 120V (Ie) 1.5 A 3 A
DC-13	(Ue) 24V (Ie) 2 A
Solenoid Characteristics	
Locking Type	Power to Release
Holding Force, Max.	5000 N (1124 lbf)
Power Supply	24V AC/DC or 110V AC or 230V AC (solenoid)
Solenoid Power	13 W typical 100% ED
Operating Characteristics	
Break Contact Force, Min.	12 N (2.7 lbf)
Actuation Speed, Max.*	160 mm (6.29 in.)/s
Actuation Frequency, Max.	2 cycles/s
Operating Radius, Min	300 mm end entry, 800 mm entry front
Operating Life @ 100 mA load	1,000,000 operations
Environmental	
Enclosure Type Rating	IP65
Operating Temperature [C (F)]	-10...+60° (+14...+140°)
Physical Characteristics	
Housing Material	Die-cast alloy
Actuator Material	Stainless Steel
Weight [g (lb)]	1200 (2.65)
Color	Red

\* Usable for ISO 13849-1:2006 and IEC 62061. Data is based on the B10d value given and:

- Usage rate of 1op/10mins., 24hrs/day, 360 days/year, representing 51840 operations per year
- Mission time/Proof test interval of 38 years

\* The safety contacts are described as normally closed (N.C.) i.e., with the guard closed, actuator in place (where relevant) and the machine able to be started.

## Safety Switches

# Guard Locking Switches

### Atlas™ 5

### Product Selection

Module Type	Actuator Type	Contact		Solenoid Contacts	Solenoid Voltage	Cat. No.			
		Safety	Auxiliary			M20 Conduit		Connector§	
						M20	1/2 inch NPT Adaptor	12-Pin M23	8-Pin Micro (M12)*
Standard	Standard	2 N.C.	1 N.O.	2 N.C. & 1 N.O.	24V AC/DC	440G-L07264	440G-L07258	440G-L07298	440G-L2NNSDH-3N
					110V AC/DC	440G-L07263	440G-L07257	—	—
					230V AC/DC	440G-L07262	440G-L07256	—	—
LH Key Lock					24V AC/DC	440G-L07255	440G-L07249	440G-L07301	440G-L2NNSDH-38
110V AC/DC					440G-L07254	440G-L07248	—	—	
230V AC/DC					440G-L07253	440G-L07247	—	—	

§ For connector ratings, see 3-9.

\* With an 8-pin micro connector, not all contacts are connected. See page 3-49 for wiring details.

### Recommended Logic Interfaces

Description	Safety Outputs	Auxiliary Outputs	Time Delay	Terminals	Reset Type	Power Supply	Cat. Page No.	Cat. No.
<b>Single-Function Safety Relays</b>								
MSR127RP	3 N.O.	1 N.C.	—	Removable (Screw)	Monitored Manual	24V AC/DC	5-26	440R-N23135
MSR127TP	3 N.O.	1 N.C.	—	Removable (Screw)	Auto./Manual	24V AC/DC	5-26	440R-N23132
MSR126T	2 N.O.	None	—	Fixed	Auto./Manual	24V AC/DC	5-24	440R-N23117
MSR30RT	2 N.O. Solid State	1 N.O. Solid State	—	Removable	Auto./Manual or Monitored Manual	24V DC	5-16	440R-N23198
<b>Specialty Safety Relays</b>								
MSR178	3 N.O.	2 N.C.	0.5 s...30 min	Removable	Automatic	24V AC/DC, 115V AC or 230V AC	5-40	440R-M23227
CU2	2 N.O.	1 N.C.	0.1 s...40 min	Fixed	—	24V AC/DC	5-56	440R-S07281
CU3	2 N.O.	1 N.C.	—	Fixed	Automatic/Manual	110V AC	5-64	440R-S35002
<b>Modular Safety Relays</b>								
MSR210P Base 2 N.C. only	2 N.O.	1 N.C. and 2 PNP Solid State	—	Removable	Auto./Manual or Monitored Manual	24V DC from the base unit	5-82	440R-H23176
MSR220P Input Module	—	—	—	Removable	—	24V DC	5-86	440R-H23178
MSR310P Base	MSR300 Series Output Modules	3 PNP Solid State	—	Removable	Auto./Manual Monitored Manual	24V DC	5-102	440R-W23219
MSR320P Input Module	—	2 PNP Solid State	—	Removable	—	24V DC from the base unit	5-106	440R-W23218

**Note:** For additional Safety Relays connectivity, see page 5-12.

For additional Safety I/O and Safety PLC connectivity, see page 5-116.

For application and wiring diagrams, see page 10-1.

### Connection Systems

Description	8-Pin Micro (M12)	12-Pin M23
Cordset	889D-F8AB-*	889M-F12AH-*
Patchcord	889D-F8ABDM-*	889M-F12AHMU-†

\* Replace symbol with 2 (2 m), 5 (5 m), or 10 (10 m) for standard cable lengths.

\* Replace symbol with 1 (1 m), 2 (2 m), 3 (3 m), 5 (5 m), or 10 (10 m) for standard cable lengths.

† Replace symbol with 0M3, (0.3 m), 0M6 (0.6 m), 1 (1 m), 2 (2 m) or 3 (3 m) for standard lengths.

**Note:** For additional information, see page 7-1.





3-Interlock Switches

# Safety Switches

## Guard Locking Switches

### Atlas™ 5

#### Accessories

Description	Dimensions	Cat. No.
 Standard actuator	3-50	440G-A07136
 Atlas Replacement End Cap	—	440G-A07180
 Fully flex actuator	3-50	440G-A07269
 Dust Cover	—	440K-A17181

#### Approximate Dimensions

Dimensions are shown in mm (in.). Dimensions are not intended to be used for installation purposes.

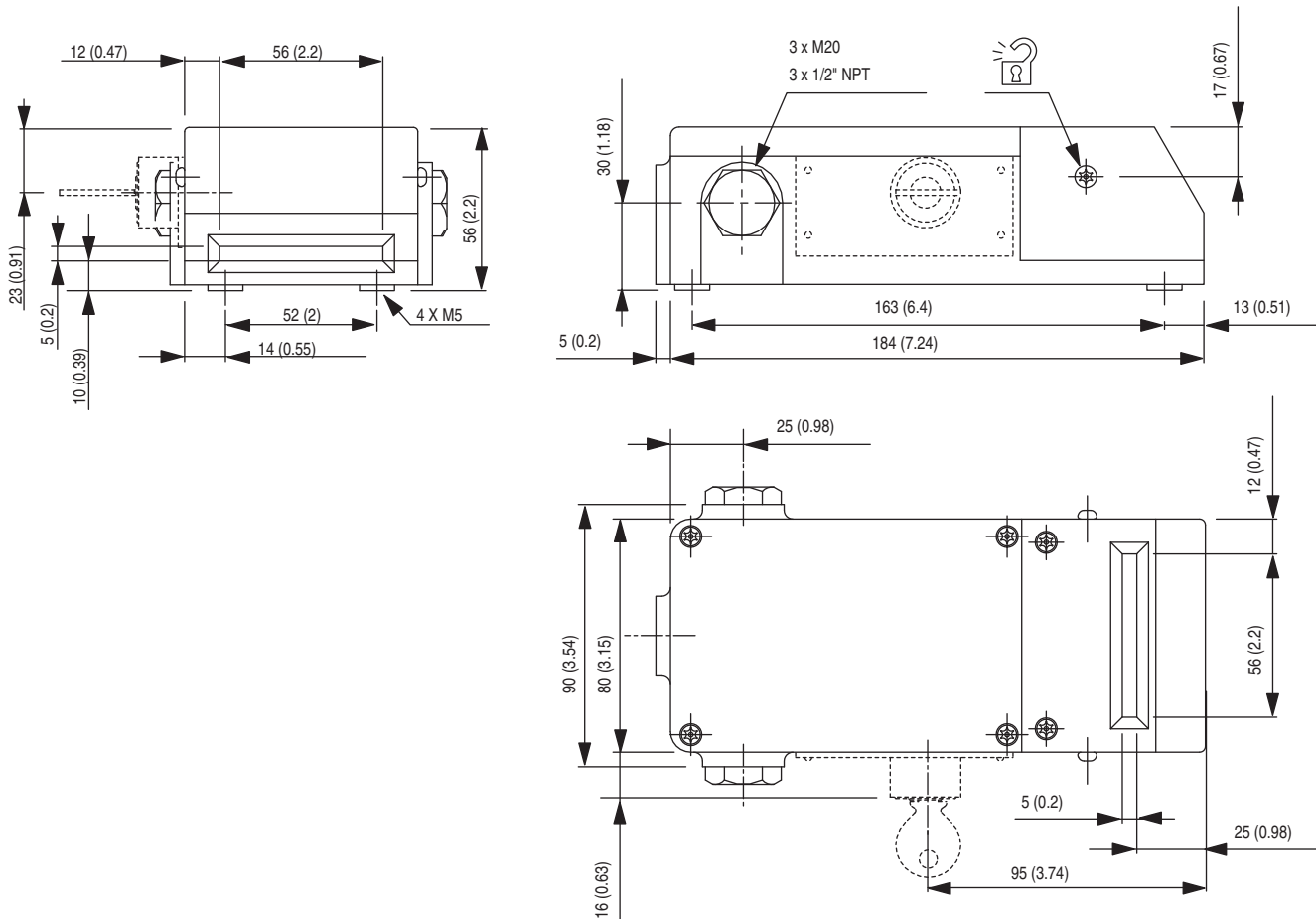

**Note:** 2D, 3D and electrical drawings are available on [www.ab.com](http://www.ab.com).

3-Interlock Switches



## Safety Switches Guard Locking Switches Atlas™ 5

### Typical Wiring Diagrams

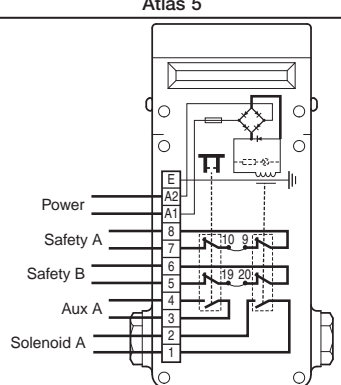
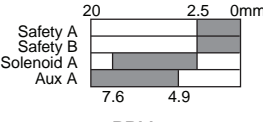
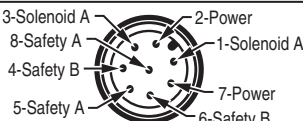
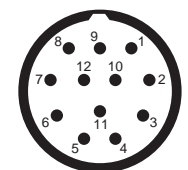
Contact Configuration	 <p style="text-align: center;">Atlas 5</p>																		
Contact Action  <input type="checkbox"/> Open <input checked="" type="checkbox"/> Closed	 <p style="text-align: center;">BBM</p>																		
8-Pin Micro (M12)	 <p style="text-align: center;">Jumpers on 9-10 and 19-20.</p>																		
12-Pin M23	<table border="1" style="width: 100%; border-collapse: collapse;"> <tr> <td style="width: 30%;"></td> <td style="width: 35%; text-align: center;">1 and 3</td> <td style="width: 35%; text-align: center;">Solenoid Power</td> </tr> <tr> <td></td> <td style="text-align: center;">4 and 6</td> <td style="text-align: center;">Safety A</td> </tr> <tr> <td></td> <td style="text-align: center;">7 and 8</td> <td style="text-align: center;">Safety B</td> </tr> <tr> <td></td> <td style="text-align: center;">2 and 5</td> <td style="text-align: center;">Aux A</td> </tr> <tr> <td></td> <td style="text-align: center;">9 and 10</td> <td style="text-align: center;">Solenoid A</td> </tr> <tr> <td></td> <td style="text-align: center;">12</td> <td style="text-align: center;">Ground</td> </tr> </table>		1 and 3	Solenoid Power		4 and 6	Safety A		7 and 8	Safety B		2 and 5	Aux A		9 and 10	Solenoid A		12	Ground
	1 and 3	Solenoid Power																	
	4 and 6	Safety A																	
	7 and 8	Safety B																	
	2 and 5	Aux A																	
	9 and 10	Solenoid A																	
	12	Ground																	
 <p style="text-align: center;">Pin 11 not connected.</p>																			
8-Pin Cordset 889D-F8AB-*	<table border="1" style="width: 100%; border-collapse: collapse;"> <tr> <td style="width: 30%;"></td> <td style="width: 35%; text-align: center;">Brown Blue</td> <td style="width: 35%; text-align: center;">Solenoid Power</td> </tr> <tr> <td></td> <td style="text-align: center;">Grey Red</td> <td style="text-align: center;">Safety A</td> </tr> <tr> <td></td> <td style="text-align: center;">Yellow Pink</td> <td style="text-align: center;">Safety B</td> </tr> <tr> <td></td> <td style="text-align: center;">White Green</td> <td style="text-align: center;">Solenoid A</td> </tr> </table>		Brown Blue	Solenoid Power		Grey Red	Safety A		Yellow Pink	Safety B		White Green	Solenoid A						
	Brown Blue	Solenoid Power																	
	Grey Red	Safety A																	
	Yellow Pink	Safety B																	
	White Green	Solenoid A																	
12-Pin Cordset 889M-F12AH-*	<table border="1" style="width: 100%; border-collapse: collapse;"> <tr> <td style="width: 30%;"></td> <td style="width: 35%; text-align: center;">Brown Grey</td> <td style="width: 35%; text-align: center;">Solenoid Power</td> </tr> <tr> <td></td> <td style="text-align: center;">Pink Yellow</td> <td style="text-align: center;">Safety A</td> </tr> <tr> <td></td> <td style="text-align: center;">White Red/Blue</td> <td style="text-align: center;">Safety B</td> </tr> <tr> <td></td> <td style="text-align: center;">Blue Red</td> <td style="text-align: center;">Aux A</td> </tr> <tr> <td></td> <td style="text-align: center;">Black Violet</td> <td style="text-align: center;">Solenoid A</td> </tr> <tr> <td></td> <td style="text-align: center;">Green</td> <td style="text-align: center;">Ground</td> </tr> </table>		Brown Grey	Solenoid Power		Pink Yellow	Safety A		White Red/Blue	Safety B		Blue Red	Aux A		Black Violet	Solenoid A		Green	Ground
	Brown Grey	Solenoid Power																	
	Pink Yellow	Safety A																	
	White Red/Blue	Safety B																	
	Blue Red	Aux A																	
	Black Violet	Solenoid A																	
	Green	Ground																	

\* Replace symbol with 2 (2 m), 5 (5 m) or 10 (10 m) for standard cable lengths.







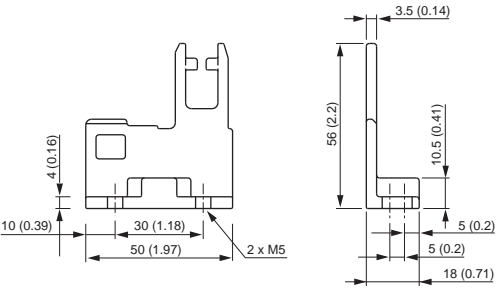

**3-Interlock  
Switches**

Safety Switches  
**Accessories**  
 Actuators

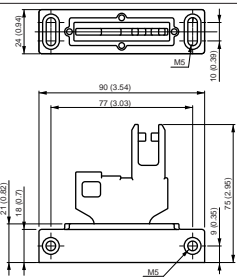
Accessories for Interlock and Guard Locking Switches

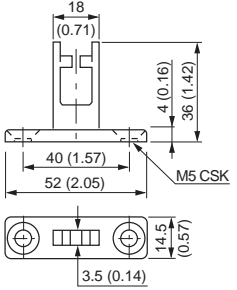
Actuators\*

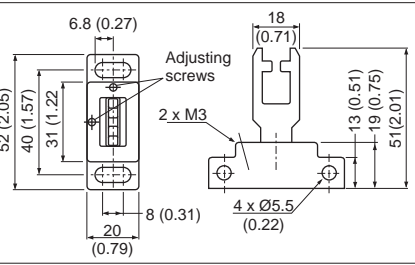

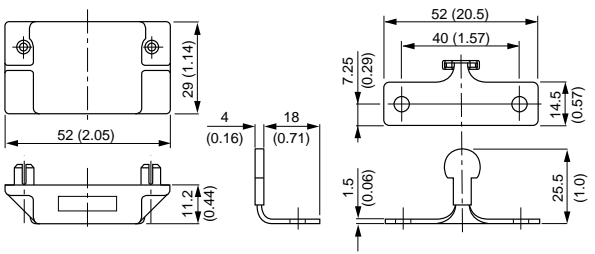





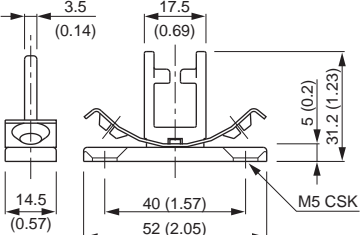

3-Interlock  
Switches

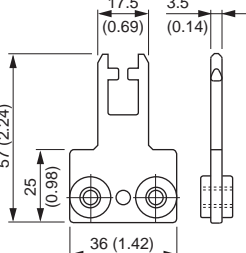
Item	Description	Approximate Dimensions [mm (in.)]	Cat. No.
	Standard actuator		440G-A07136
	Fully flex actuator		440G-A07269
	GD2 standard actuator		440G-A27011
	Fully flex actuator		440G-A27143
	Catch and Retainer Kit		440K-A11094

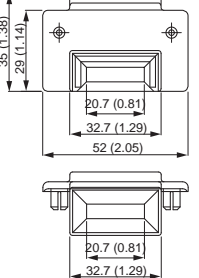
\* See page 3-8 for Switch Compatibility table.

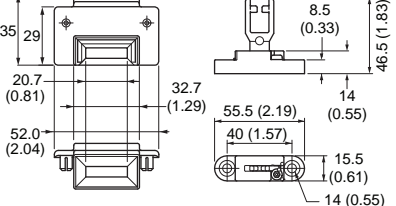
Safety Switches  
Accessories  
Actuators

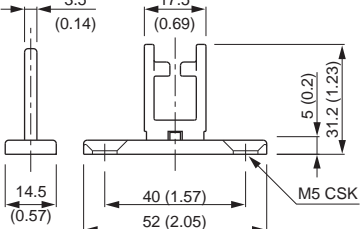
Actuators\* (continued)

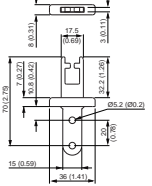





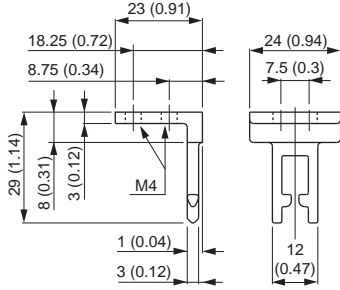

Item	Description	Approximate Dimensions [mm (in.)]	Cat. No.
	Standard actuator		440K-A11095
	GD2 flat actuator		440K-A11112
	Replacement Alignment Guide		440K-A11115
	Alignment guide with semi-flexible actuator		440K-A11144
	Standard actuator		440K-A11238
	Extended flat actuator		440K-A17116

3-Interlock  
Switches

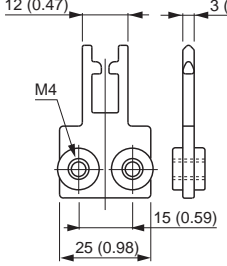
\* See page 3-8 for Switch Compatibility table.

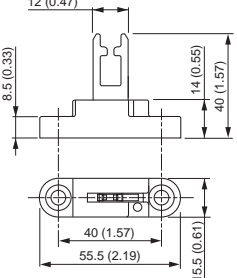
Safety Switches  
**Accessories**  
 Actuators

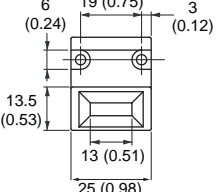
Actuators\* (continued)

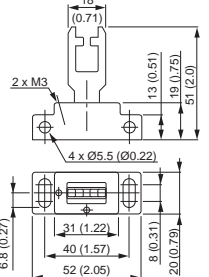
Item	Description	Approximate Dimensions [mm (in.)]	Cat. No.
	90° actuator, not to be used with metal alignment guide		440K-A21006
	Flat actuator, not to be used with metal alignment guide		440K-A21014
	Metal alignment guide with semi-flexible actuator		440K-A21030
	Metal Alignment Guide		440K-A21069
	Alignment guide with fully-flexible actuator		440K-A27010







\* See page 3-8 for Switch Compatibility table.

3-Interlock Switches





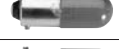
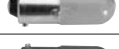

## Safety Switches Accessories

### Beacons, Bulbs and Conduits

#### Beacons and Bulbs

Item	Description	Cat. No.
	Indicator, M20 Conduit Pilot Light—Amber Lens T-3 1/4 Insert Use T-3 1/4 Bulb (Sold Separately)	440A-A19001
	Indicator, M20 Conduit Pilot Light—Red Lens T-3 1/4 Insert Use T-3 1/4 Bulb (Sold Separately)	440A-A19002
	Indicator, 1/2 inch NPT Conduit Pilot Light—Amber Lens T-3 1/4 Insert Use T-3 1/4 Bulb (Sold Separately)	440A-A19005
	Indicator, 1/2 inch NPT Conduit Pilot Light—Red Lens T-3 1/4 Insert Use T-3 1/4 Bulb (Sold Separately)	440A-A19007
	Bulb, 24V for Conduit Pilot Light 2.8W T-3 1/4 Bulb, Miniature Screw Base	440A-A09056
	Bulb, 110V for Conduit Pilot Light 2.6W T-3 1/4 Bulb, Miniature Screw Base	440A-A09055
	Bulb, 240V for Conduit Pilot Light 0.75W T-3 1/4 Bulb, Miniature Screw Base	440A-A09054
	Red LED Bulb, 24V AC/DC for Conduit Pilot Light Bayonet Style Insert	800T-N319R
	Amber LED Bulb, 24V AC/DC for Conduit Pilot Light Bayonet Style Insert	800T-N319A
	Red LED Bulb, 120V AC for Conduit Pilot Light Bayonet Style Insert	800T-N320R
	Amber LED Bulb, 120V AC for Conduit Pilot Light Bayonet Style Insert	800T-N320A

#### Conduit Accessories

Item	Description	Cat. No.
	Blanking plug, M20 conduit	440A-A07265
	Cable Grip, M16 Conduit, Accommodates Cable Diameter 4...7 mm (0.27...0.16 in.)	440A-A09004
	Cable grip, M20 conduit, accommodates cable diameter 7...10.5 mm (0.27...0.41 in.)	440A-A09028
	Adaptor, conduit, M20 to 1/2 inch NPT, plastic	440A-A09042
	Adaptor, Conduit, 1/2 inch NPT to M16, Brass	440A-A09093
	Adaptor, Conduit, M16 to 1/2 inch NPT, Brass	440A-A09094









**3-Interlock  
Switches**

Safety Switches



Accessories

Replacement and Dust Covers, Emergency Override, and Flex Release

Replacement Covers

Item	Description	Cat. No.
	Elf™	440A-A33085
	Cadet™	440A-A21115
	Trojan T15	440A-A11499
	Trojan 5 Standard Models Only	440A-A11495
	Trojan T5 GD2	440A-A11496
	Trojan T6 Standard Models Only	440A-A11497
	Trojan T6 GD2	440A-A11498
	440G-MT No LED, No Override	440G-MT47120
	440G-MT LED and Override	440G-MT47123
	Cover for TLS-1 with external override key for series D and earlier	440G-A27140
	Cover for TLS-3 with external override key for series D and earlier	440G-A27142
	Cover for TLS-1 with override key attached for series D and earlier	440G-A27207
	Cover for TLS-3 with override key attached for series D and earlier	440G-A27208
	Atlas Replacement End Cap	440G-A07180

Dust Covers

Item	Applicable Switch	Cat. No.
	Elf Cadet	440K-A17182
	Trojan T15, T5, and T6 All Models MT G2 440G-MT	440K-A17180
	TLS-GD2	440K-A17183
	Atlas 5	440K-A17181

3-Interlock Switches

Emergency Override

Item	Description	Cat. No.
	TLS-GD2/440G-MT Solenoid Emergency Override (See Warning below.)	440G-A36026



**WARNING:** Do not attach the Emergency Override Key to the TLS-GD2/440G-MT switch.

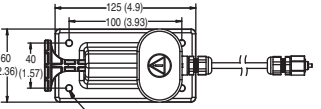
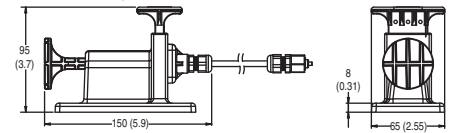

Flex Release

Item	Description	Approximate Dimensions [mm (in.)]	Cat. No.
	Flexible Release—1 m (3.28 ft) Cable		440G-A27356
	Flexible Release—3 m (9.84 ft) Cable		440G-A27357





Safety Switches  
**Accessories**  
 Tools and Door Handles

**Tools**

Item	Description	Cat. No.
	Security Bit	440A-A09015
	Screwdriver Including Security Bit	440A-A09018

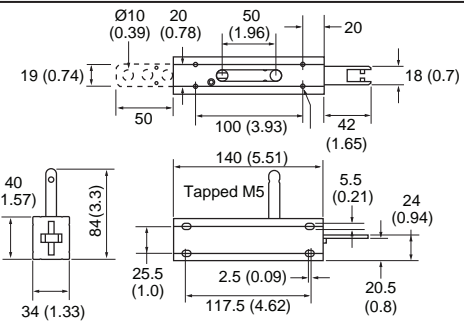
**Door Handles**

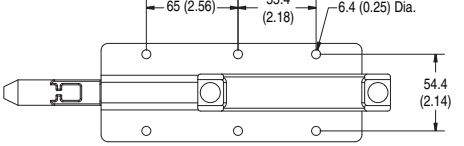
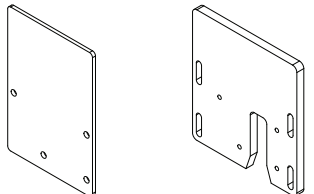
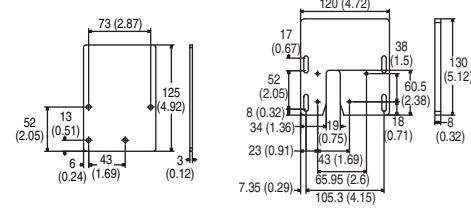
Item	Description	Dimensions [mm (in.)]	Cat. No.
	Sliding bolt actuator		440G-A27163
	Sliding Bolt		440K-AMDS
	Sliding Bolt Mounting Plate for TLS-GD2		440K-AMDSSMPB

3-Interlock  
Switches

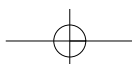

## Safety Switches

### Non-Contact Switches

#### SensaGuard™



#### Description

When it comes to machine safety, Rockwell Automation knows that protection of personnel and equipment is your main concern. At the same time, flexibility and productivity are points that must also be considered as you design your safety system. Optimize all of these with the new Allen-Bradley SensaGuard family of non-contact switches.

Featuring the latest generation of RFID technology for coding and inductive technology for sensing, SensaGuard's large sensing range and tolerance to misalignment is a cost-effective solution that is ideally suited for a wide range of industrial safety applications.

The SensaGuard product line is a Category 4/SIL 3 rated switch per EN954-1, TÜV functional safety approved to IEC 61508.

#### Features

- Switches can be connect to a standard safety relay, for example, the MSR126, MSR127, MSR200/300 Family, SmartGuard™ and Safety I/O Blocks
- Multiple actuator sizes for large sensing distance
- IP69K environmental rating
- Short-circuit and over-voltage protection
- LED located on the switch for door status and troubleshooting
- Unique coded version
  - Automatic learn process at unit power up
  - During commissioning you have the option to select if the sensor can learn a new actuator up to eight times or lock the unit so it can not learn another actuator
- Integrated latch version
  - Adjustable magnetic latch force 20...60N
  - Designed for easy mounting on aluminum profile

#### Benefits

- No dedicated controller required
- Cat 4/SIL 3 rating maintained even with multiple units connected in series
- Switches can be connected in series with other devices (light curtain, E-stops, key interlock switches)
- Extended diagnostics for easy troubleshooting
- Large sensing distances
- Tolerance to misalignment
- Multiple sensing directions
- Stainless steel version suitable for use in harsh environments
- Use standard proximity brackets

#### Specifications

Safety Ratings		
Standards	IEC 60947-5-3, IEC 61508, EN 954	
Safety Classification	Cat. 4/SIL3	
Functional Safety Data *	PFH <sub>D</sub> : > 1.12 x 10 <sup>-9</sup> MTTF <sub>d</sub> : > 385 years Dual channel interlock may be suitable for performance levels PLe or PLd (according to ISO 13849-1:2006) and for use in SIL2 or SIL3 systems (according to IEC 62061) depending on application characteristics	
Note:	For up-to-date information, visit <a href="http://www.ab.com/Safety/">http://www.ab.com/Safety/</a>	
Certifications	CE Marked for all applicable directives, cULus (UL 508), and TÜV	
Outputs (Guard Door Closed, Actuator in Place)		
Safety Outputs	2 x PNP, 0.2 A, max.; Status: ON (+24V DC)	
Auxiliary Outputs	1 x PNP, 0.2 A max.; Status: OFF (0V DC)	
Operating Characteristics		
Sensing Distance (Assure)	18 mm Plastic Barrel/18 mm Target	15 mm (0.59 in.)
	18 mm Plastic Barrel/30 mm Target	25 mm (0.98 in.)
	18 mm Stainless Steel Barrel/Standard Target	10 mm (0.39 in.)
	Large Rectangular Flat Pack with Standard Target	15 mm (0.59 in.)
Misalignment Tolerance, Min	See misalignment curve	
Repeat Accuracy	10% of Sensing Range	
Output Current, Max.	200 mA (all outputs)	
Operating Voltage	24V DC, +10%/-15% Class 2	
Current Consumption	50 mA	
Frequency of Operating Cycle	1 Hz	
Response Time (Off)	54 ms	
Environmental		
Enclosure Type Rating	NEMA 3, 4X, 12, 13, IP69K	
Operating Temperature [C (F)]	-10...+55° (+14...+131°)	
Relative Humidity	5...95%	
Shock	IEC 68-2-27, 30 g, 11 ms	
Vibration	IEC 68-2-6 10...55 Hz	
Radio Frequency	IEC 61000-4-3, IEC 61000-4-6	
Physical Characteristics		
Housing Material	VALOX® DR 48	
Actuator Material	VALOX® DR 48	
Color	Red	

- \* Usable for ISO 13849-1:2006 and IEC 62061. Data other than B10d is based on:
- Usage rate of 1op/10 mins., 24 hrs/day, 360 days/year, representing 51840 operations per year
  - Mission time/Proof test interval of 30 years



## Safety Switches

# Non-Contact Switches

### SensaGuard™

### Product Selection

Type	Assured Sensing Distance	LED Door Indication/Diagnostic	Margin Indication	Magnetic Hold	Actuator Code Type	Cat. No.		
						Cable		Connector
						3 m	10 m	6 inch Pigtail, 8-pin Micro (M12)
18 mm plastic barrel/18 mm actuator	15 mm (0.59 in.)	Yes	—	—	Standard	440N-Z21S16A	440N-Z21S16B	<b>440N-Z21S16H</b>
					Unique	440N-Z21U16A	440N-Z21U16B	440N-Z21U16H
18 mm plastic barrel/30 mm actuator	25 mm (0.98 in.)	Yes	—	—	Standard	440N-Z21S26A	440N-Z21S26B	<b>440N-Z21S26H</b>
					Unique	440N-Z21U26A	440N-Z21U26B	440N-Z21U26H
18 mm stainless steel barrel/18 mm actuator	10 mm (0.39 in.)	Yes	—	—	Standard	440N-Z21S17A	440N-Z21S17B	<b>440N-Z21S17H</b>
					Unique	440N-Z21U17A	440N-Z21U17B	440N-Z21U17H
Plastic rectangular/rectangular actuator	18 mm (0.71 in.)	Yes	—	—	Standard	440N-Z21SS2A	440N-Z21SS2B	<b>440N-Z21SS2H</b>
					Unique	440N-Z21US2A	440N-Z21US2B	440N-Z21US2H
			Yes	—	Standard	440N-Z21SS2AN	440N-Z21SS2BN	<b>440N-Z21SS2HN</b>
					Unique	440N-Z21US2AN	440N-Z21US2BN	440N-Z21US2HN
			Yes	Yes (9 N)	Standard	440N-Z21SS2AN9	440N-Z21SS2BN9	440N-Z21SS2HN9
					Unique	440N-Z21US2AN9	440N-Z21US2BN9	440N-Z21US2HN9
Plastic housing with integrated latch	Contact/latched	Yes	—	Adjustable 20...60 N	Standard	440N-Z21SS3PA	440N-Z21SS3PB	440N-Z21SS3PH
					Unique	440N-Z21US3PA	440N-Z21US3PB	440N-Z21US3PH

### Recommended Logic Interfaces

Description	Safety Outputs	Auxiliary Outputs	Terminals	Reset Type	Power Supply	Cat. Page No.	Cat. No.
<b>Single-Function Safety Relays</b>							
MSR127RP	3 N.O.	1 N.C.	Removable (Screw)	Monitored Manual	24V AC/DC	5-26	<b>440R-N23135</b>
MSR127TP				Auto./Manual		5-26	<b>440R-N23132</b>
<b>Modular Safety Relays</b>							
MSR211P Base 2 N.C. only	2 N.O.	1 N.C.	Removable	Auto./Manual or Monitored Manual	24V DC from the base unit	5-84	440R-H23177
MSR220P Input Module	—	—	Removable	—	24V DC	5-86	440R-H23178
MSR310P Base	MSR300 Series Output Modules	3 PNP Solid State	Removable	Auto./Manual Monitored Manual	24V DC	5-102	440R-W23219
MSR320P Input Module	—	2 PNP Solid State	Removable	—	24V DC from the base unit	5-106	440R-W23218

**Note:** For additional Safety Relays connectivity, see page 5-12.  
For additional Safety I/O and Safety PLC connectivity, see page 5-116.  
For application and wiring diagrams, see page 10-1.

### Connection Systems

Description	Cat. No.
Cordset	889D-F8AB-*
Patchcord	889D-F8ABDM-*
Safety Wired T-Port	898D-438Y-D8
Safety Wired Shorting Plug	898D-418U-DM

\* Replace symbol with 2 (2 m), 5 (5 m), or 10 (10 m) for standard cable lengths.  
\* Replace symbol with 1 (1 m), 2 (2 m), 3 (3 m), 5 (5 m), or 10 (10 m) for standard lengths.  
**Note:** For additional information, see page 7-1.











**3-Interlock Switches**

## Safety Switches

### Non-Contact Switches

#### SensaGuard™

#### Accessories

Description		To Be Used With	Cat. No.
	18 mm plastic actuator	Standard coded models only	440N-Z18PT
		Unique coded models only	440N-Z18UPT
	30 mm plastic actuator	Standard coded models only	440N-Z30PT
		Unique coded models only	440N-Z30UPT
	18 mm stainless steel actuator	Standard coded models only	440N-Z18SST
		Unique coded models only	440N-Z18USST
	Rectangular plastic actuator	Standard coded models only	440N-ZPREC
		Unique coded models only	440N-ZUPREC
		Standard coded margin/magnetic hold models only	440N-ZPRECM
		Unique coded margin/magnetic hold models only	440N-ZUPRECM
	Integrated latch actuator	Standard coded models only	440N-ZLPREC
		Unique coded models only	440N-ZULPREC
	Mounting bracket for tubular proximity sensors—right angle style	18 mm barrel models	871A-BRS18
	Mounting bracket for tubular sensors—clamp style		871A-BP18
	Snap clamp mounting bracket		871A-SCBP18
	Swivel/tilt bracket allows $\pm 10^\circ$ vertical and $360^\circ$ rotation adjustment		60-2649
	Mounting plate for vertically hinged doors		Integrated latch version only
	Mounting plate for slide and gull wing doors	440N-ASDB	

3-Interlock  
Switches

# Safety Switches

## Non-Contact Switches

### SensaGuard™

#### Approximate Dimensions

Dimensions are shown in mm (in.). Dimensions are not intended to be used for installation purposes.

#### 18 mm Barrel

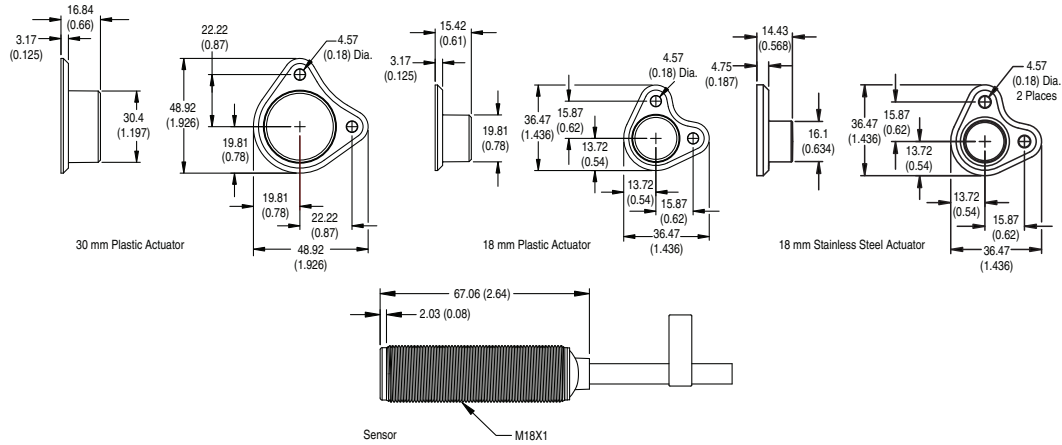

#### Large Rectangular Flat Pack

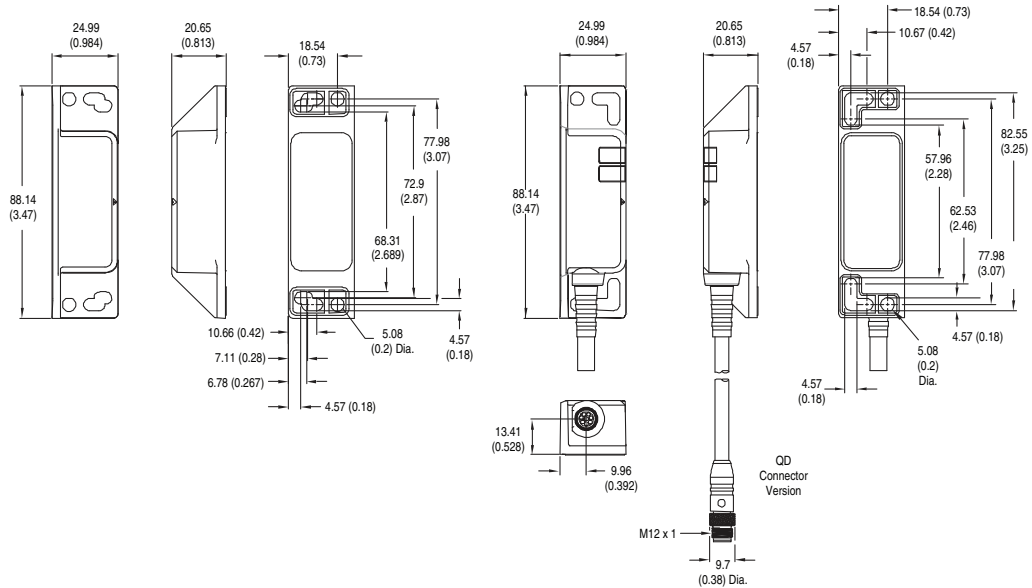

3-Interlock Switches

#### Integrated Latch

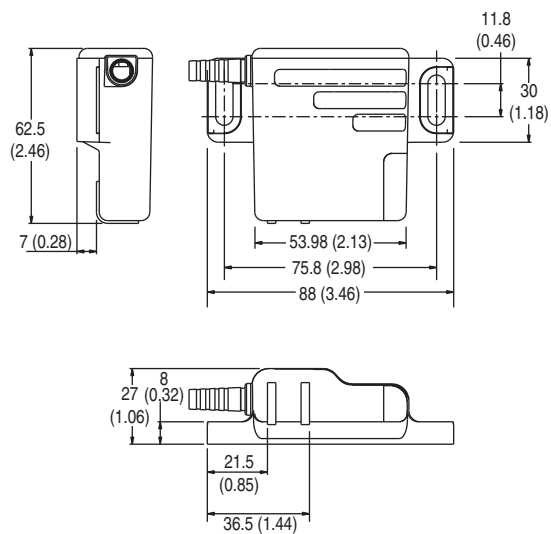

# Safety Switches

## Non-Contact Switches

### SensaGuard™

#### Typical Wiring Diagrams

Description		Plastic	Stainless Steel
8-Pin Micro (M12)			
8-Pin Cordset 889D-F8AB- or cable version	Grey	Safety A	Safety A
	Red	Safety A+	Safety A+
	Pink	Safety B	Safety B
	Yellow	Safety B+	Safety B+
	White	Aux A	Aux A
	Brown	24V DC +	24V DC +
	Blue	Gnd	Gnd
	Green	NA	Shield

\* Replace symbol with 2 (2 m), 5 (5 m) or 10 (10 m) for standard cable lengths.

#### Misalignment Curves

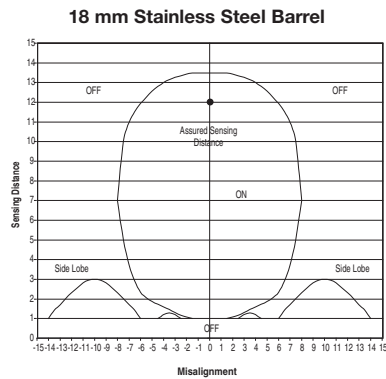

**Note:** There must be a minimum spacing of 4 mm (0.157 in.) if actuator and sensor face approaches laterally. This will prevent false triggering due to the side lobe areas.

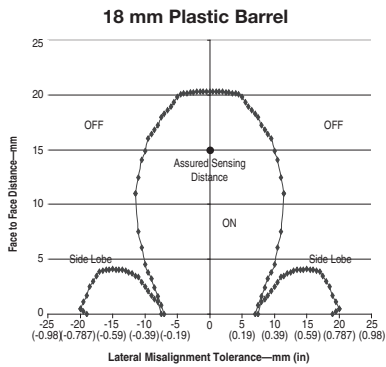

**Note:** There must be a minimum spacing of 4 mm (0.157 in.) if actuator and sensor face approaches laterally. This will prevent false triggering due to the side lobe areas.

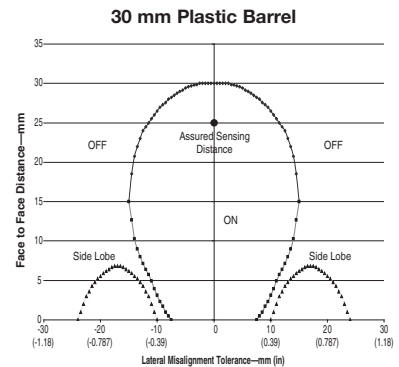

**Note:** There must be a minimum spacing of 7 mm (0.275 in.) if actuator and sensor face approaches laterally. This will prevent false triggering due to the side lobe areas.

3-Interlock  
Switches

# Safety Switches

## Non-Contact Switches

### SensaGuard™

#### Large Rectangular Flat Pack

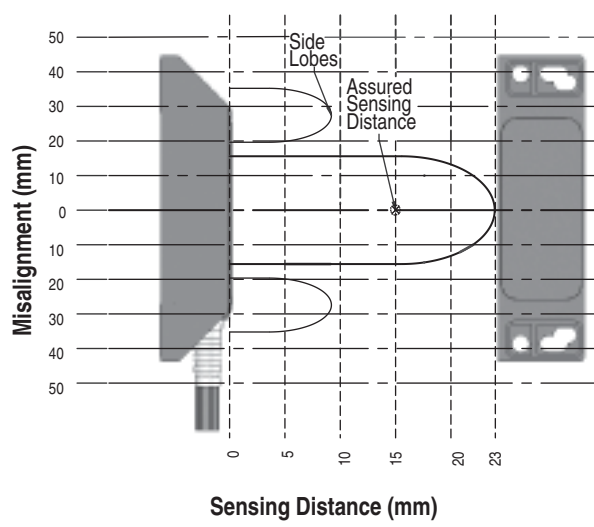
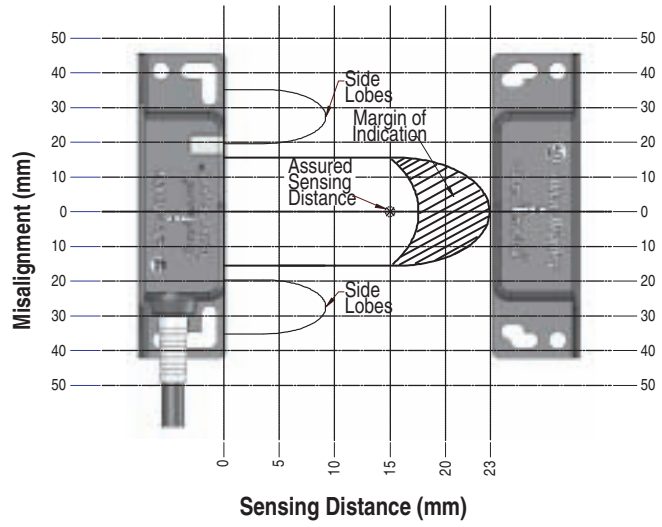

#### Minimum Distance Between Sensors

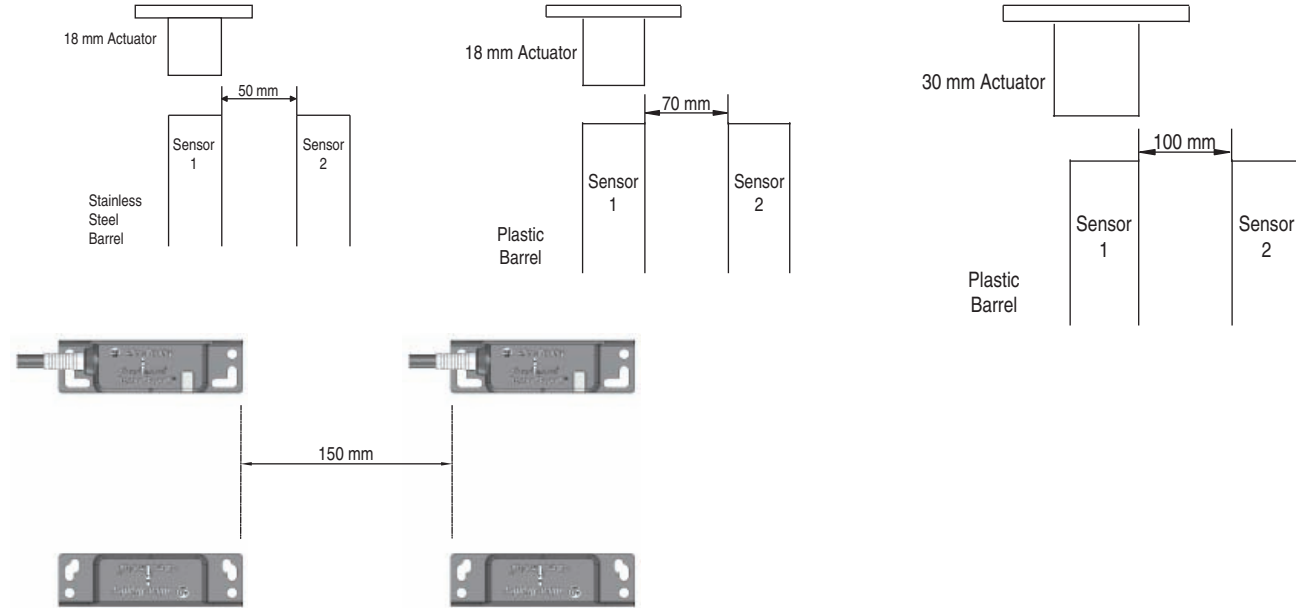

**3-Interlock Switches**

# Safety Switches

## Non-Contact Switches

### SensaGuard™

#### Diagnostic

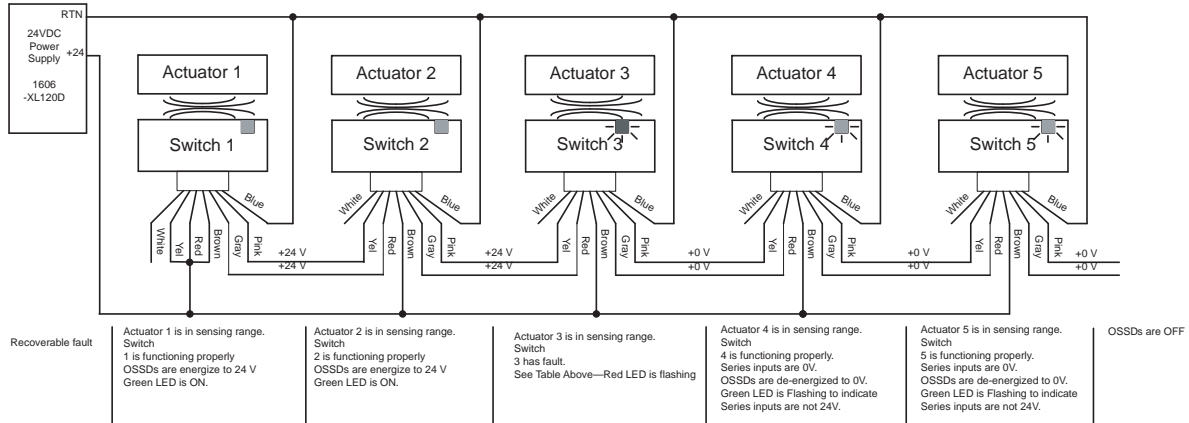

#### Unit Indicators (per IEC 60073)

	State	Status	Troubleshooting
Device Output LED	Off	Not Powered	NA
	Red	Not Safe, Output Off	NA
	Green	Safe, Output On	NA
	Green Flash	Power Up Test	Check 24V DC on Safety + Outputs (yellow and red wire)
	Red Flash	1 Hz Flash Recoverable Fault 4 Hz Flash Nonrecoverable Fault	Recoverable Fault: Check Safety Outputs Are Not Shorted to GND, 24V DC or Each Other. Cycle Power.
	Amber Flash	Safe, Output On, Sensor Is Reaching Max. Sensing Distance	Re-adjust Distance Between Actuator and Sensor until Output LED Is Green

### 3-Interlock Switches

#### Unit Response Time

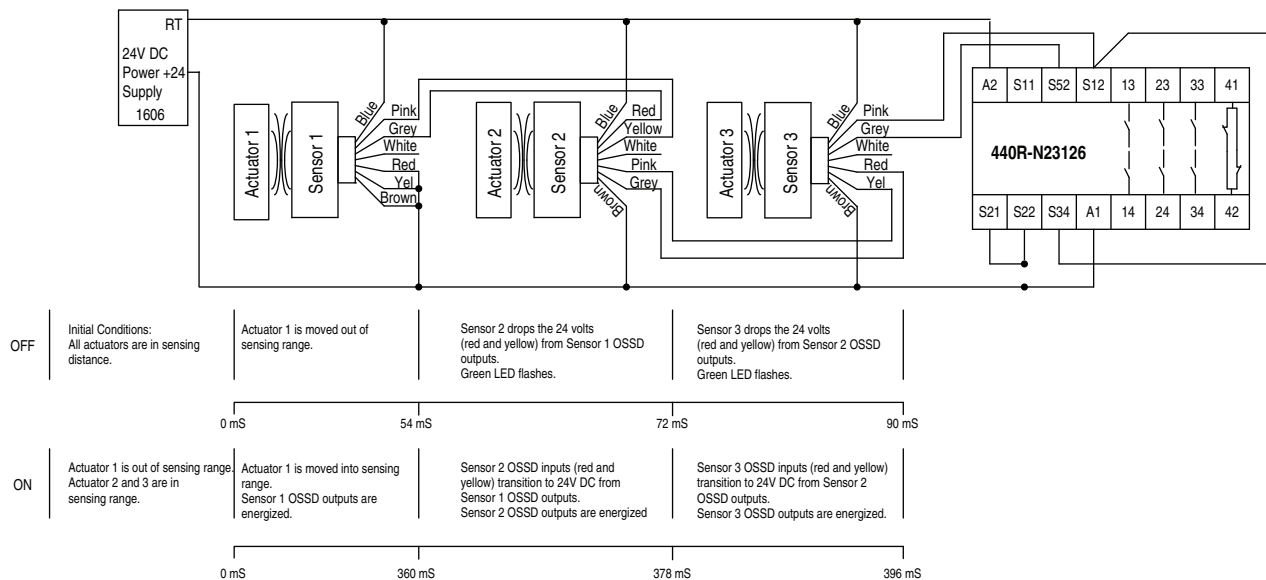

# Safety Switches Non-Contact Switches SensaGuard™

## Application Wiring Examples

### MSR127RP with One Sensor

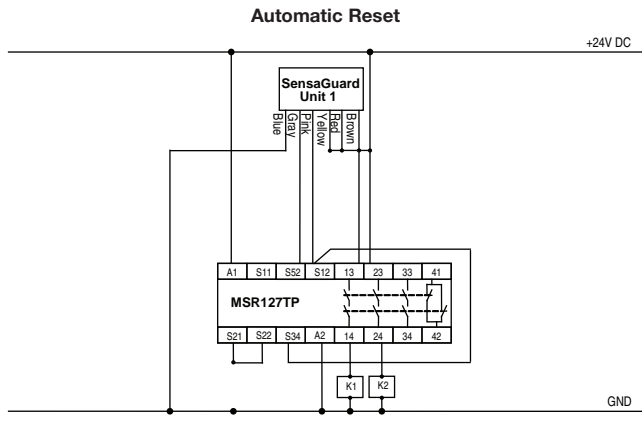
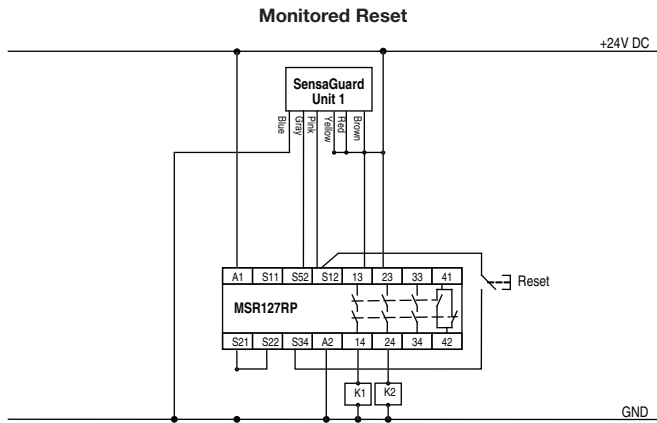

### MSR127RP with Three Sensors

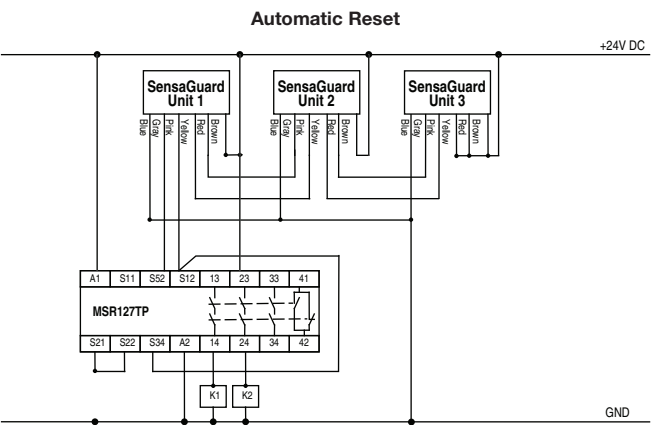
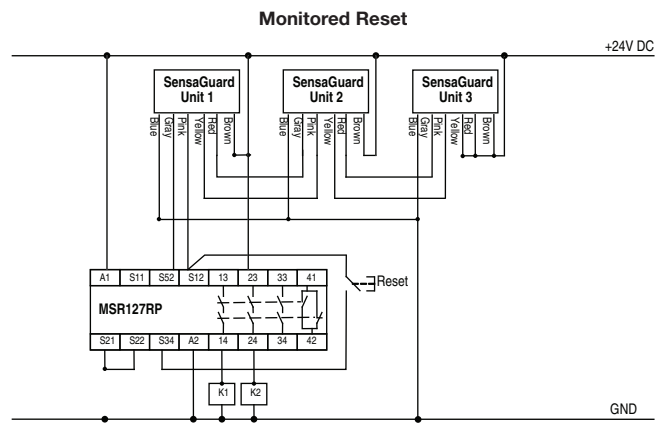

### MSR127RP with Two Sensors and One Light Curtain

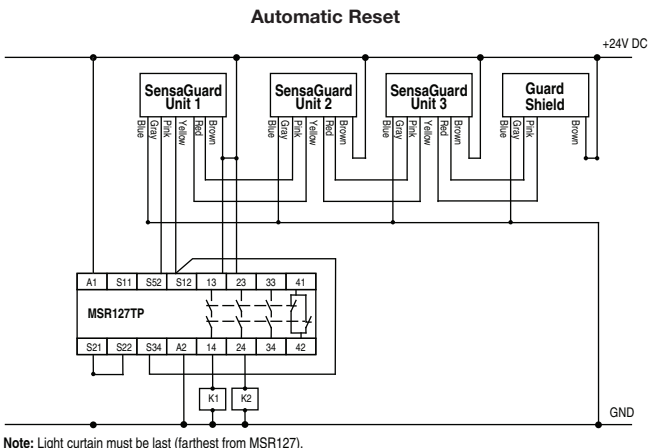
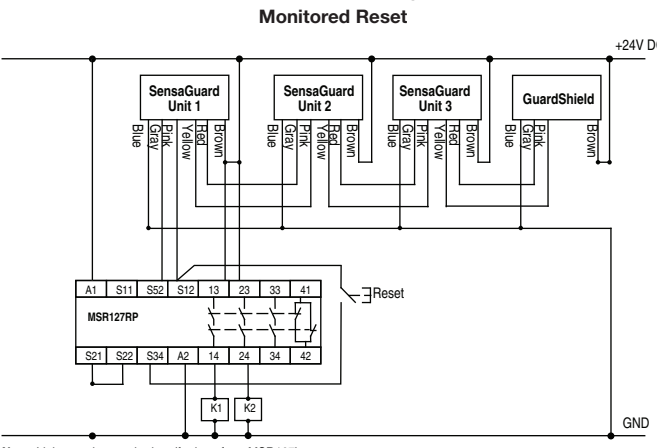

Note: Light curtain must be last (farthest from MSR127).

Note: Light curtain must be last (farthest from MSR127).

3-Interlock  
Switches

# Safety Switches

## Non-Contact Switches

### SensaGuard™

#### MSR200 Series with Three Sensors and One Light Curtain

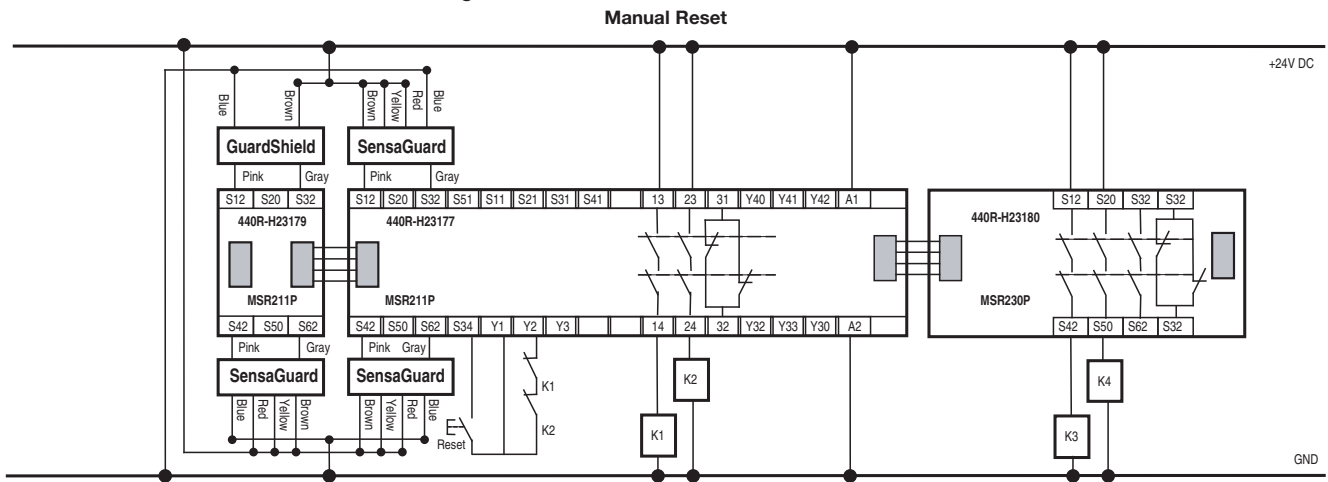

Note: Light curtain can be attached to any input.

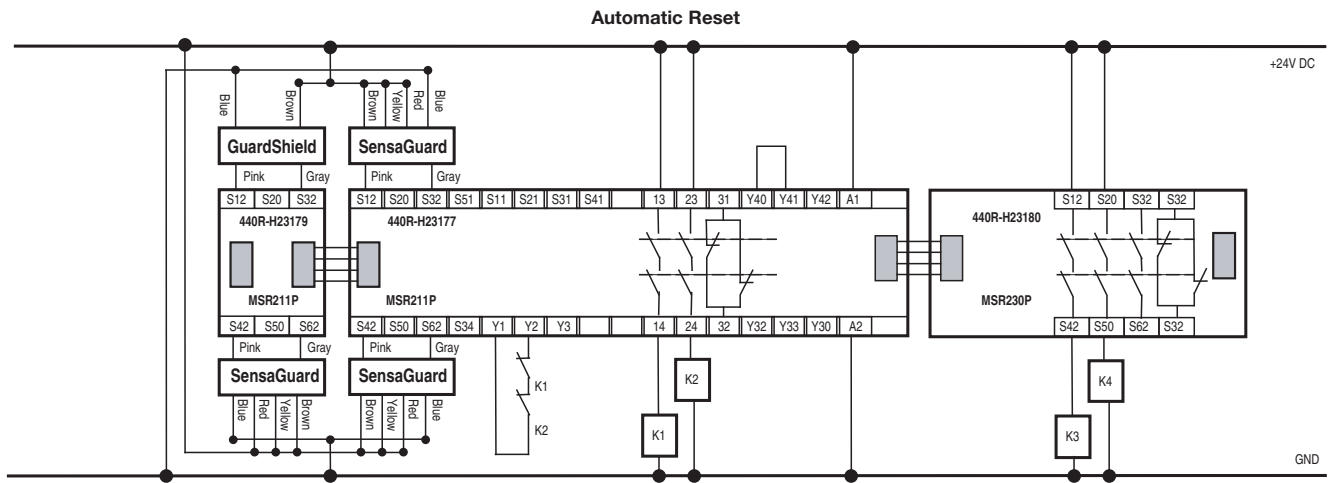

Note: Light curtain can be attached to any input

3-Interlock Switches



# Safety Switches Non-Contact Switches SensaGuard™

## MSR200 Series with Four Sensors

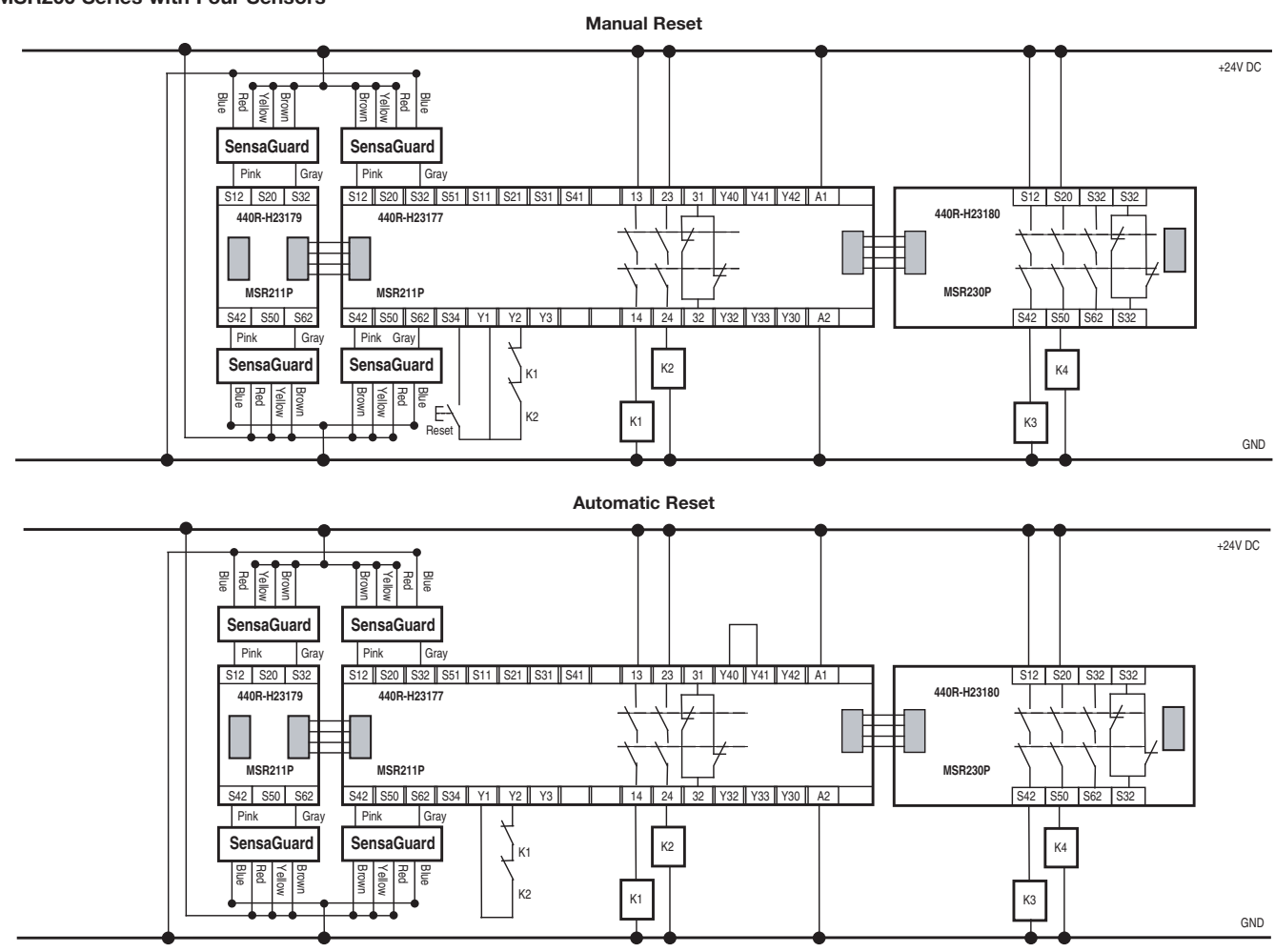

3-Interlock  
Switches

## Safety Switches

### Non-Contact Switches

#### Magnetically Coded

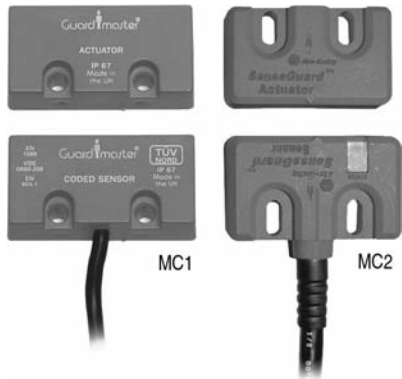

#### Description

With the increasing speed and complexity of applications a simple magnetic switch may be insufficient to meet the increased risks, therefore the design incorporates several magnetically sensitive elements which must be triggered in a particular sequence to operate correctly.

The sensor with its molded-in brackets and diminutive size, is extremely versatile and simple to install. For high-risk applications the control unit is used with a single sensor to give a high-integrity system. For other applications, multiple sensors (including mechanical switches) can be connected.

#### Features

- Non-contact actuation
- Magnetic coded sensing
- High tolerance to misalignment
- Designed for use with specified controllers

3-Interlock  
Switches

#### Specifications

	MC1	MC2
<b>Safety Ratings</b>		
Standards	EN954-1, ISO13849-1, IEC/EN60204-1, NFPA79, EN1088, ISO14119, IEC60947-5-1, IEC/EN60947-5-3, ANSI B11.19, AS4024.1	
Safety Classification	Cat. 1 Device per EN 954-1; Dual channel interlocks suitable for Cat. 3 or 4 systems	
Functional Safety Data *	B10d: > 2 x 10 <sup>6</sup> operations at min. PFH <sub>D</sub> : > 3 x 10 <sup>-7</sup> MTTFd: > 385 years Dual channel interlock may be suitable for performance levels PLe or PLd (according to ISO 13849-1:2006) and for use in SIL2 or SIL3 systems (according to IEC 62061) depending on application characteristics	
Certifications	CE Marked for all applicable directives, cULus, and TÜV	
<b>Outputs (Guard Door Closed, Actuator in Place)</b>		
Safety Outputs	2 N.C. REEDS	2 N.C. Solid-State Relays
Auxiliary Outputs	—	1 x PNP, 0.2 A max.; Status: OFF (0V DC)
<b>Operating Characteristics</b>		
Operating Distance, Make [mm (in.)]	8 (0.3)	10 (0.39)
Operating Distance, Break [mm (in.)]	15 (0.59)	25 (0.98)
Misalignment Tolerance, Min	See Misalignment Wire	
Repeat Accuracy	10% of Sensing Range	
Output Current, Max.	200 mA	200 mA
Switching Current @ Voltage, Max.	24V DC @ 200 mA	24V DC @ 200 mA +10%/-15%
Operating Voltage/Power Supply	—	24V DC, +10%/-15%/50 mA max./Class 2 SELV
Frequency of Operating Cycle	1 Hz	1 Hz
<b>Environmental</b>		
Enclosure Type Rating	IP67 (NEMA 6P)	IP 69K
Operating Temperature [C (F)]	-10...+55° (+14...+131°)	
Relative Humidity	5...95%	
Shock	IEC 68-2, 27, 30 g, 11 ms	
Vibration	IEC 68-2-6, 10...55 Hz	
Radio Frequency	IEC 61000-4-3, IEC 61000-4-6	
<b>Physical Characteristics</b>		
Housing Material	Molded ABS	Ultrador
Actuator Material	Molded ABS	Ultrador
Color	Red	

- \* Usable for ISO 13849-1:2006 and IEC 62061. Data other than B10d is based on:
- Usage rate of 1op/10 mins., 24 hrs/day, 360 days/year, representing 51840 operations per year
  - Mission time/Proof test interval of 38 years

## Safety Switches

# Non-Contact Switches

### Magnetically Coded

#### Product Selection

Type	Operating Voltage/Input Current	Safety Outputs	Auxiliary Outputs	Status Indicator	Connection	Cat. No.
MC1	—	2 N.C. REEDS	—	No	—	440N-Z2NRS1C
					—	440N-Z2NRS1A
					10 m Cable	440N-Z2NRS1B
MC2	24V DC, +10%/-15%/50 mA max.	2 N.C. Solid-State Relays	1 x PNP, 0.2 A max.; Status: OFF (0V DC)	Yes	8-Pin Micro (M12)	440N-Z21W1PH
					—	440N-Z21W1PA
					—	440N-Z21W1PB

#### Recommended Logic Interfaces

Description	Safety Outputs	Auxiliary Outputs	Terminals	Reset Type	Power Supply	Cat. Page No.	Cat. No.
<b>Single-Function Safety Relays for 2 N.C. Contact Switch</b>							
MSR127RP	3 N.O.	1 N.C.	Removable (Screw)	Monitored Manual	24V AC/DC	5-26	440R-N23135
MSR127TP	3 N.O.	1 N.C.	Removable (Screw)	Auto./Manual	24V AC/DC	5-26	440R-N23132
<b>Modular Safety Relays</b>							
MSR210P Base 2 N.C. only	2 N.O.	1 N.C. and 2 PNP Solid State	Removable	Auto./Manual or Monitored Manual	24V DC from the base unit	5-82	440R-H23176
MSR220P Input Module	—	—	Removable	—	24V DC	5-86	440R-H23178
MSR310P Base	MSR300 Series Output Modules	3 PNP Solid State	Removable	Auto./Manual Monitored Manual	24V DC	5-102	440R-W23219
MSR320P Input Module	—	2 PNP Solid State	Removable	—	24V DC from the base unit	5-106	440R-W23218

**Note:** For additional Safety Relays connectivity, see page 5-12.  
For additional Safety I/O and Safety PLC connectivity, see page 5-116.  
For application and wiring diagrams, see page 10-1.

#### Connection Systems

Description	Connection to Distribution Box 4-Pin Micro (M12)	8-Pin Micro (M12)
	2 N.C.	2 N.C. & 1 N.O.
Cordset	889D-F4AC-*	889D-F8AB-*
Patchcord	889D-F4ACDM-*	889D-F8ABDM-*
Distribution Box	898D-4†LT-DM4	—
Shorting Plug	898D-41LU-DM	—
T-Port	898D-43LY-D4	—

\* Replace symbol with 2 (2 m), 5 (5 m), or 10 (10 m) for standard cable lengths.  
\* Replace symbol with 1 (1 m), 2 (2 m), 3 (3 m), 5 (5 m), or 10 (10 m) for standard cable lengths.  
† Replace symbol with 4 or 8 for number of ports.

**Note:** For additional information, see the page 7-1.

#### Accessories

Description	Cat. No.
MC1 Spare Actuator	440N-A17233
MC2 Spare Actuator	440N-A32114

3-Interlock  
Switches

# Safety Switches

## Non-Contact Switches

### Magnetically Coded

#### Approximate Dimensions

Dimensions are shown in mm (in.). Dimensions are not intended to be used for installation purposes.

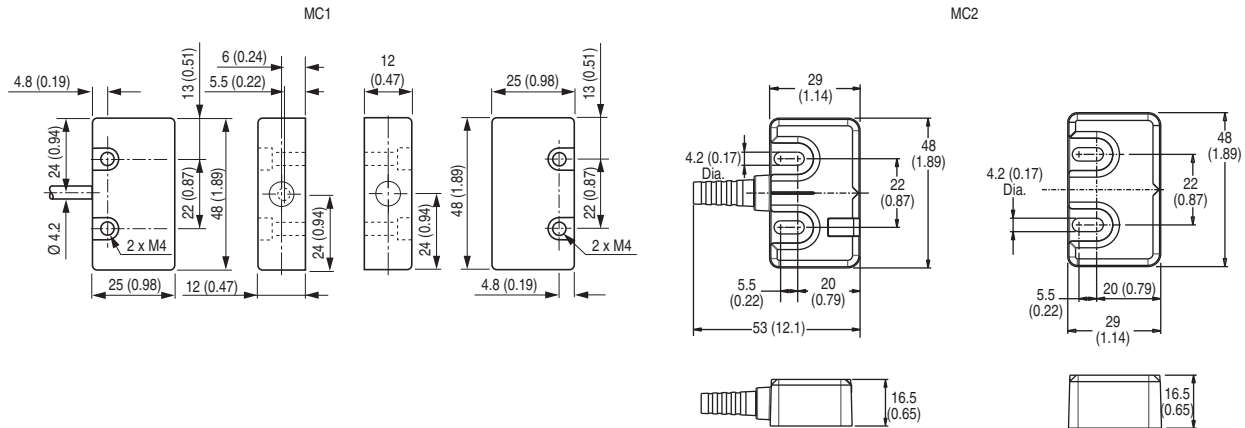

#### Typical Wiring Diagrams

Description		MC1	MC2
		2 N.C.	2 N.C. + 1 N.O.
4-Pin Micro (M12)			—
8-Pin Micro (M12)		—	
Cordset 889D-F4AC-* or Cable Version	Brown	Safety A	—
	Blue	Safety B	—
	White	—	—
	Black	—	—
8-Pin Cordset 889D-F8AB-* or Cable Version	Grey	—	Safety A
	Red	—	Safety A
	Pink	—	Safety B
	Yellow	—	Safety B
	White	—	Aux
	Brown	—	24V DC +
	Blue	—	Gnd
	Green	—	NA

\* Replace symbol with 2 (2 m), 5 (5 m) or 10 (10 m) for standard cable lengths.

3-Interlock Switches

# Safety Switches Non-Contact Switches Magnetically Coded

## Sensing & Misalignment Curve

### MC1

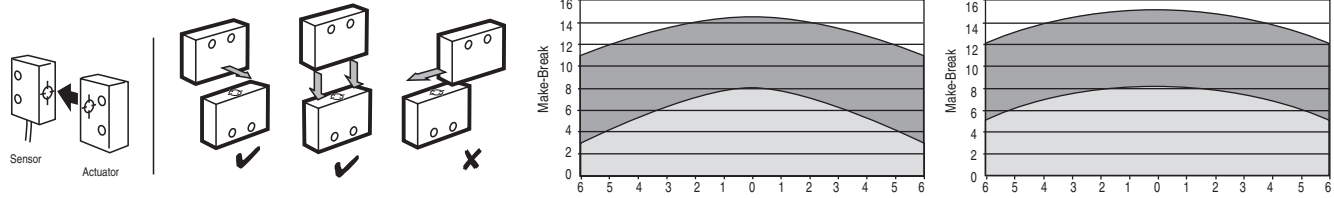

### MC2

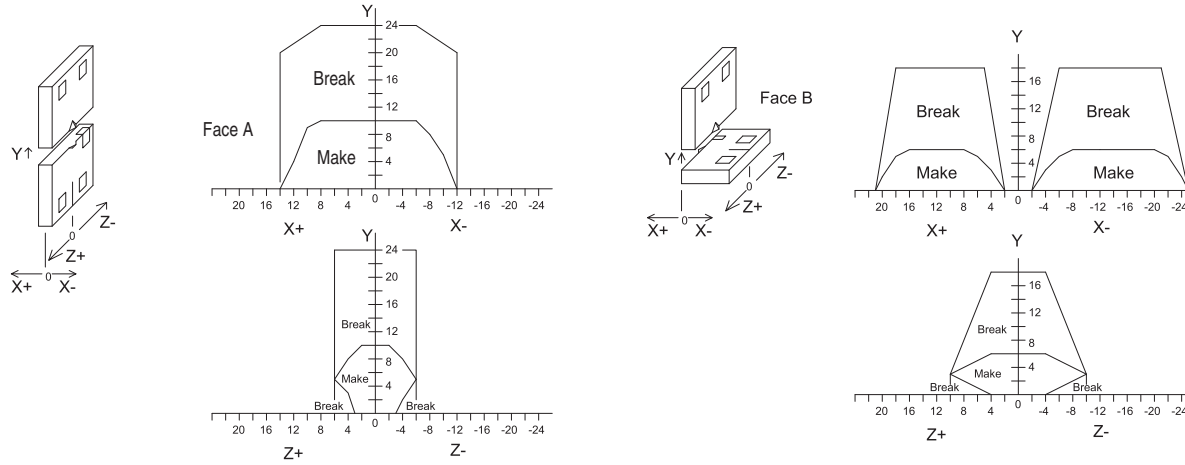

## MC2 Application Wiring Example

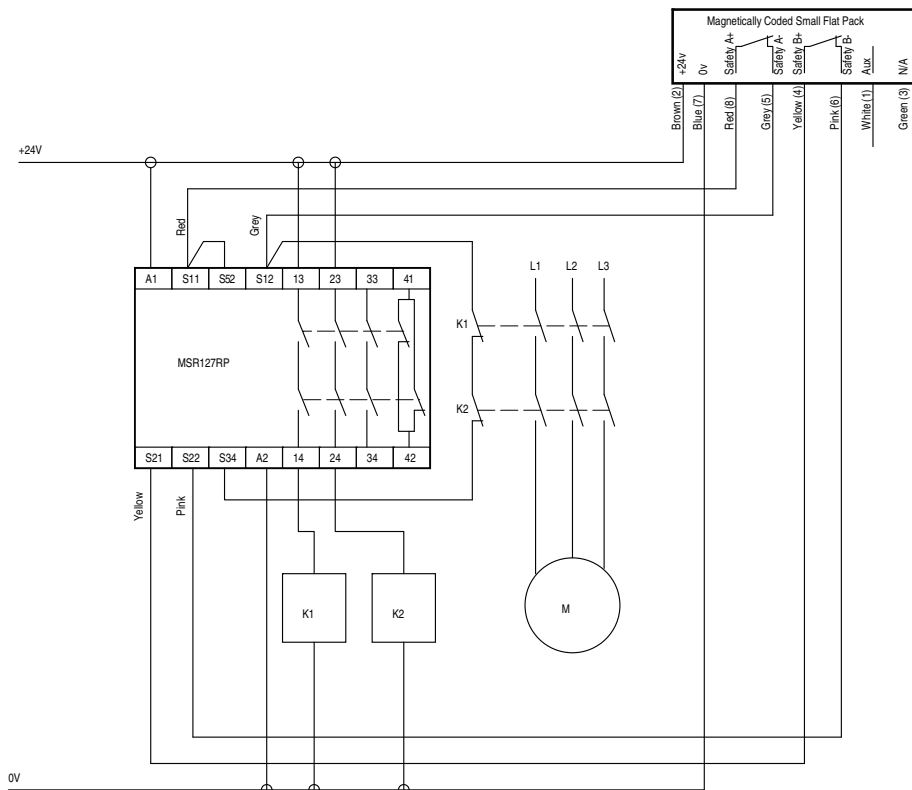

3-Interlock  
Switches

## Safety Switches

### Non-Contact Switches

#### Ferrogard™ 1, 2, 20 & 21



#### Description

The Ferrogard range of magnetically actuated safety switches offers non-contact reliability together with tolerance to misalignment. They are designed to be installed so that when a guard door is opened, the action of the magnetic actuator being removed from the switch opens the N.C. safety contacts which are intended for the isolation of control power to a machine primary control element.

The FRS1, FRS2, FRS20, FRS21 are rectangular housings. Sealed to IP67 (NEMA 6P), these Ferrogards are ideal for wet environments.

Unlike some magnetic switches the Ferrogards have protected safety contacts to help ensure that they do not fail to danger. In addition, some versions have independent auxiliary signal contacts to indicate the guard condition.

All Ferrogards have internal non-resettable overload protection on the safety contact. They should be protected by an external fuse rated as shown in the Specifications table.

3-Interlock  
Switches

#### Features

- Non-contact actuation
- High tolerance to misalignment
- High switching current (up to 2 A AC, 1 A DC)
- Plastic rectangular housing (IP67)
- Cable or quick-disconnect (QD) connections

#### Specifications

Safety Ratings	
Standards	EN954-1, ISO13849-1, IEC/EN60204-1, NFPA79, EN1088, ISO14119, ANSI B11.19, AS4024.1
Safety Classification	Cat. 1 Device per EN954-1 Dual channel interlocks suitable for Cat. 3 or 4 systems
Functional Safety Data <b>Note:</b> For up-to-date information, visit <a href="http://www.ab.com/Safety/">http://www.ab.com/Safety/</a>	B10d: > 2 x 10 <sup>6</sup> operations at min. PFH <sub>D</sub> : > 3 x 10 <sup>-7</sup> MTTFd: > 385 years Dual channel interlock may be suitable for performance levels PLe or PLd (according to ISO 13849-1:2006) and for use in SIL2 or SIL3 systems (according to IEC 62061) depending on application characteristics
Certifications	CE Marked for all applicable directives and cULus
Outputs (Guard Door Closed, Actuator in Place)	
Safety Outputs	FRS1: 1 N.C., FRS2: 1 N.C., FRS20: 2 N.C., FRS21: 2 N.C.
Auxiliary Outputs	FRS1: None, FRS2: 1 N.O., FRS20: None, FRS21: 1 N.O.
Operating Characteristics	
Operating Distance, Make [mm (in.)]	Safety: 12 (0.47); Auxiliary: 15 (0.59)
Operating Distance, Break [mm (in.)]	Safety: 23 (0.91); Auxiliary: 26 (1.02)
Fuses, External	FRS1, 2 & 21: 1.6 A (Bussmann BK/60 A-1.6 A) max. FRS20: 0.4 A (Bussmann BK/60 A-400 mA) max.
Environmental	
Enclosure Type Rating	IP67 (NEMA 6P)
Operating Temperature [C (F)]	-10...+55° (+14...+131°)
Relative Humidity	5...95%
Shock	50 g
Vibration	7 g; 50...200 Hz
Radio Frequency	IEC 61000-4-3, IEC 61000-4-6
Physical Characteristics	
Actuator/Housing Material	Molded ABS plastic
Weight [g (lbs)]	FRS 1—Sensor: 35 (0.08)/Actuator: 85 (0.19) FRS 2—Sensor: 40 (0.09)/Actuator: 85 (0.19) FRS 20—Sensor: 43 (0.09)/Actuator: 85 (0.19) FRS 21—Sensor: 43 (0.09)/Actuator: 85 (0.19)
Color	Red

- \* Usable for ISO 13849-1:2006 and IEC 62061. Data other than B10d is based on:
- Usage rate of 1op/10 mins., 24 hrs/day, 360 days/year, representing 51840 operations per year
  - Mission time/Proof test interval of 38 years

## Safety Switches Non-Contact Switches Ferrogard™ 1, 2, 20 & 21

### Product Selection

Safety Contact Switching Capability	Safety Contacts	Auxiliary Contacts	Connection	Type	Cat. No.
250V AC, 2 A max	1 N.C.	—	2 m Cable	FRS 1	440N-G02001
			4 m Cable		440N-G02004
			6 m Cable		440N-G02022
			8 m Cable		440N-G02041
			10 m Cable		440N-G02015
		1 N.O.	2 m Cable	FRS 2	440N-G02002
			4 m Cable		440N-G02014
			6 m Cable		440N-G02038
			8 m Cable		440N-G02033
			10 m Cable		440N-G02019
	2 N.C.	—	15 m Cable	440N-G02043	
			20 m Cable	440N-G02040	
			4-Pin Micro QD	440N-G02093	
	2 N.C.	—	4-Pin Micro QD	FRS 20	440N-G02097
	2 N.C.	1 N.O.	2 m Cable	FRS 21	440N-G02055
			4 m Cable		440N-G02061
			6 m Cable		440N-G02060
			10 m Cable		440N-G02059
6-Pin AC Micro QD§			440N-G02098		
24V DC, 1 A	1 N.C.	1 N.O.	2 m Cable	FRS 2	440N-G02092
			4-Pin Micro QD		<b>440N-G02094</b>
	2 N.C.	—	4 m Cable	FRS 20	440N-G02085
			4-Pin Micro QD		<b>440N-G02090</b>
		1 N.O.	2 m Cable	FRS 21	440N-G02058
			4 m Cable		440N-G02077
			6 m Cable		440N-G02083
			6-Pin Micro QD		<b>440N-G02099</b>

**Note:** Contacts are described with the guard door closed, that is, actuator in place. Switch is shipped complete with actuator.  
§ For connector ratings see 3-9.

**3-Interlock  
Switches**

## Safety Switches

### Non-Contact Switches

#### Ferrogard™ 1, 2, 20 & 21

#### Recommended Logic Interfaces

Description	Safety Outputs	Auxiliary Outputs	Terminals	Reset Type	Power Supply	Cat. Page No.	Cat. No.
<b>Single-Function Safety Relays for 2 N.C. Contact Switch</b>							
MSR127RP	3 N.O.	1 N.C.	Removable (Screw)	Monitored Manual	24V AC/DC	5-26	440R-N23135
MSR127TP	3 N.O.	1 N.C.	Removable (Screw)	Auto./Manual	24V AC/DC	5-26	440R-N23132
MSR30T	2 N.O. Solid State	1 N.O. Solid State	Removable	Auto./Manual or Monitored Manual	24V DC	5-16	440R-N23198
<b>Single-Function Safety Relays for 1 N.C. &amp; 1 N.O. Contact Switch</b>							
MSR9T	2 N.O.	1 N.C.	Fixed	Auto./Manual	24V AC/DC	5-14	440R-F23027
MSR33RT	2 N.O. Solid State	1 N.O.	Removable	Auto. or Monitored Manual	24V DC SELV	5-18	440R-F23200
<b>Modular Safety Relays</b>							
MSR211P Base 2 N.C. only	2 N.O.	1 N.C. and 2 PNP Solid State	Removable	Auto./Manual or Monitored Manual	24V DC from the base unit	5-84	440R-H23176
MSR220P Input Module	—	—	Removable	—	24V DC	5-86	440R-H23178
MSR310P Base	MSR300 Series Output Modules	3 PNP Solid State	Removable	Auto./Manual Monitored Manual	24V DC	5-102	440R-W23219
MSR320P Input Module	—	2 PNP Solid State	Removable	—	24V DC from the base unit	5-106	440R-W23218

**Note:** For additional Safety Relays connectivity, see page 5-12.  
 For additional Safety I/O and Safety PLC connectivity, see page 5-116.  
 For application and wiring diagrams, see page 10-1.

#### Connection Systems

Description	Connection to Distribution Box	
	4-Pin Micro (M12) 1 N.C. & 1 N.O.	6-Pin Micro (M12) 2 N.C. & 1 N.O.
Cordset	889D-F4AC-*	889R-F6ECA-*
Patchcord	889D-F4ACDM-*	889R-F6ECRM-*
Distribution Box	898D-P4†KT-DM4	898R-F68MT-A5
Shorting Plug	898D-41KU-DM	898R-P61MU-RM
T-Port	898D-43KY-D4	—

#### Accessories

Description	Cat. No.
Replacement Actuator	440N-A02005

3-Interlock Switches

\* Replace symbol with 2 (2 m), 5 (5 m), or 10 (10 m) for standard cable lengths.  
 \* Replace symbol with 1 (1 m), 2 (2 m), 3 (3 m), 5 (5 m), or 10 (10 m) for standard cable lengths.  
 † Replace symbol with 4 or 8 for number of ports.  
**Note:** For additional information, see the Safety Connection System section (page 7-1) of this catalog.

#### Approximate Dimensions

Dimensions are shown in mm (in.). Dimensions are not intended to be used for installation purposes.

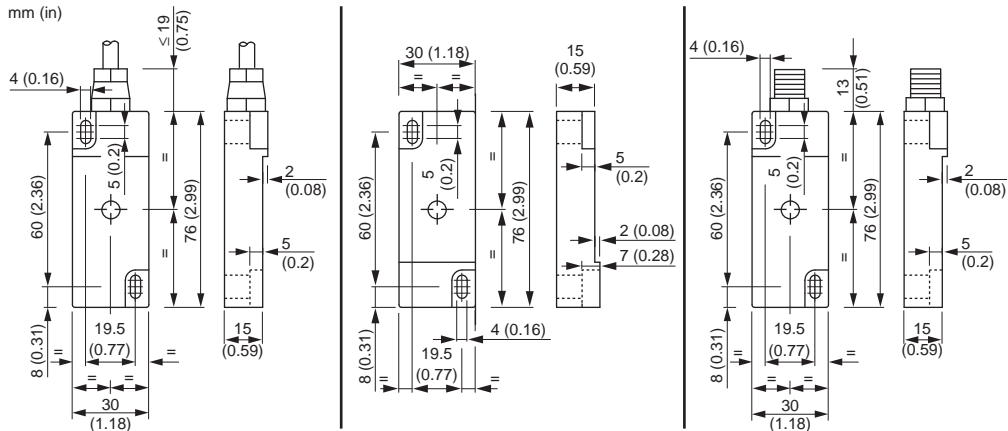



## Safety Switches Non-Contact Switches Ferrogard™ 1, 2, 20 & 21

### Typical Wiring Diagrams

		FRS1	FRS2	FRS20	FRS21
		1 N.C.	1 N.C. + 1 N.O.	2 N.C.	2 N.C. + 1 N.O.
4-Pin Micro (M12)		—			—
6-Pin Micro (M12)		—	—	—	
Cordset 889D-F4AC-* or Cable Versions	Brown	—	Safety A	Safety A	—
	Blue	—	—	—	—
	Black	—	Aux A	Safety B	—
	White	—	—	—	—
Cordset 889R-F6ECA-*	Red/White	—	—	—	Safety A
	Red/Black	—	—	—	—
	Red	—	—	—	Safety B
	Red/Blue	—	—	—	—
	Green	—	—	—	Aux A
Cable Versions	Safety A	Brown	Blue	Brown	Black
		Blue	White	Blue	White
	Safety B	—	Yellow	Black	Red
		—	Green	White	Blue
	Aux A	—	—	—	Yellow
		—	—	—	Green

\* Replace symbol with 2 (2 m), 5 (5 m) or 10 (10 m) for standard cable lengths.

3-Interlock  
Switches

## Safety Switches

### Non-Contact Switches

#### Ferrogard™ 3, 4 & 5

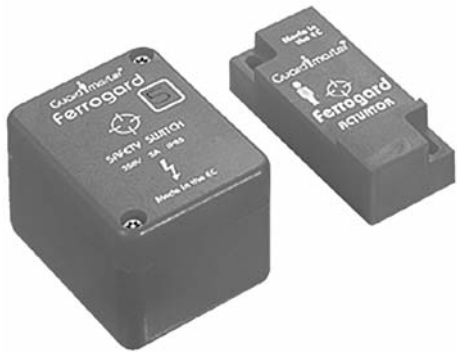

#### Description

The Ferrogard range of magnetically actuated switches offers non-contact reliability together with tolerance to misalignment. They are designed to be installed so that when a guard door is opened, the action of the magnetic actuator being removed from the switches opens the N.C. safety contacts which are intended for the isolation of control power to a machine primary control element.

The FRS 3, 4 and 5 have terminal connections. The user must drill a hole in the housing at a convenient location to allow the wiring to enter the housing. The cover is secured with anti-tamper security screws.

Unlike some magnetic switches the Ferrogards have protected safety contacts to help ensure that they do not fail to danger. In addition, some versions have independent auxiliary signal contacts to indicate the guard condition.

All Ferrogards have internal non-resettable overload protection on the safety contact. They should be protected by an external fuse rated as shown in the Specifications table.

#### Features

- Non-contact actuation
- High tolerance to misalignment
- High switching current (up to 2 A)
- Various contact arrangements
- Terminal connections

3-Interlock  
Switches

#### Specifications

Safety Ratings	
Standards	EN954-1, ISO13849-1, IEC/EN60204-1, NFPA79, EN1088, ISO14119, ANSI B11.19, AS4024.1
Safety Classification	Cat. 1 Device per EN954-1 Dual channel interlocks suitable for Cat. 3 or 4 systems
Functional Safety Data *	B10d: > 2 x 10 <sup>6</sup> operations at min. PFH <sub>D</sub> : > 3 x 10 <sup>-7</sup> MTTFd: > 385 years Dual channel interlock may be suitable for performance levels PLe or PLd (according to ISO 13849-1:2006) and for use in SIL2 or SIL3 systems (according to IEC 62061) depending on application characteristics
<b>Note:</b> For up-to-date information, visit <a href="http://www.ab.com/Safety/">http://www.ab.com/Safety/</a>	
Certifications	CE Marked for all applicable directives and cULus
Outputs (Guard Door Closed, Actuator in Place)	
Safety Outputs	FRS3: 1 N.C., FRS4: 1 N.C., FRS5: 1 N.C.
Auxiliary Outputs	FRS3: 1 N.C., FRS4: 1 N.O., FRS5: None
Operating Characteristics	
Operating Distance, Make [mm (in.)]	Safety/Auxiliary: FRS 3—12 (0.47); FRS 4—12 (0.47); FRS 5—12 (0.47)
Operating Distance, Break [mm (in.)]	Safety/Auxiliary: FRS 3—24 (0.94); FRS 4—10 (0.39); FRS 5—12 (0.47)
Auxiliary Contact Switching Capability, Min	300V DC, 250V AC 0.5 A including inrush
Safety Contact External Fusing	≤1.6 A quick blow
Environmental	
Enclosure Type Rating	IP65 (NEMA 13)
Operating Temperature [C (F)]	-10...+65° (+14...+149°)
Relative Humidity	5...95%
Shock	IEC 68-2-27, 30 g, 11 ms
Vibration	IEC 68-2-6, 10...200 Hz
Radio Frequency	IEC 61000-4-3, IEC 61000-4-6
Physical Characteristics	
Housing Material	Molded ABS plastic
Actuator Material	Molded ABS plastic
Color	Red

- \* Usable for ISO 13849-1:2006 and IEC 62061. Data other than B10d is based on:
- Usage rate of 1op/10 mins., 24 hrs/day, 360 days/year, representing 51840 operations per year
  - Mission time/Proof test interval of 38 years

## Safety Switches Non-Contact Switches Ferrogard™ 3, 4 & 5

### Product Selection

Safety Contact Switching Capability	Connection Type	Housing Material	Safety Contacts	Auxiliary Contacts	Type	Cat. No.
250V AC 2 A max	Terminals	Red Molded ABS Plastic	1 N.C.	1 N.C.	FRS 3	440N-G02003
				1 N.O.	FRS 4	440N-G02008
				—	FRS 5	440N-G02009

**Note:** Contacts are described with the guard door closed, that is, actuator in place.

### Recommended Logic Interfaces

Description	Safety Outputs	Auxiliary Outputs	Terminals	Reset Type	Power Supply	Cat. Page No.	Cat. No.
<b>Single-Function Safety Relays</b>							
MSR127RP	3 N.O.	1 N.C.	Removable (Screw)	Monitored Manual	24V AC/DC	5-26	440R-N23135
MSR127TP	3 N.O.	1 N.C.	Removable (Screw)	Auto./Manual	24V AC/DC	5-26	440R-N23132
MSR126T	2 N.O.	None	Fixed	Auto./Manual	24V AC/DC	5-24	440R-N23117
MSR30T	2 N.O. Solid State	1 N.O. Solid State	Removable	Auto./Manual or Monitored Manual	24V DC	5-16	440R-N23198
<b>Modular Safety Relays</b>							
MSR210P Base 2 N.C. only	2 N.O.	1 N.C. and 2 PNP Solid State	Removable	Auto./Manual or Monitored Manual	24V DC from the base unit	5-82	440R-H23176
MSR220P Input Module	—	—	Removable	—	24V DC	5-86	440R-H23178
MSR310P Base	MSR300 Series Output Modules	3 PNP Solid State	Removable	Auto./Manual Monitored Manual	24V DC	5-102	440R-W23219
MSR320P Input Module	—	2 PNP Solid State	Removable	—	24V DC from the base unit	5-106	440R-W23218

**Note:** For additional Safety Relays connectivity, see page 5-12.  
For additional Safety I/O and Safety PLC connectivity, see page 5-116.  
For application and wiring diagrams, see page 10-1.

### Accessories

Description	Cat. No.
Replacement Actuator	440N-A02005

### Approximate Dimensions

Dimensions are shown in mm (in.). Dimensions are not intended to be used for installation purposes.

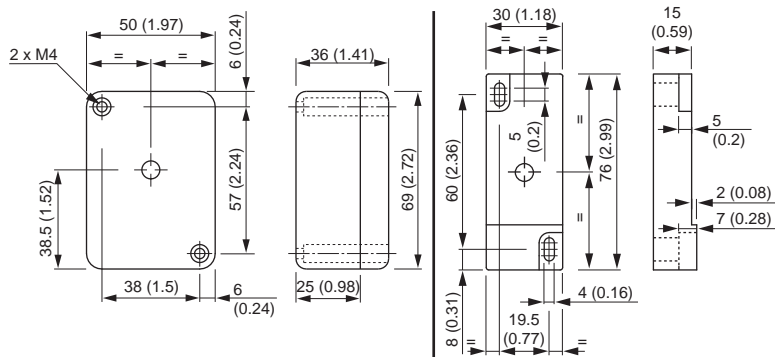

### Typical Wiring Diagrams

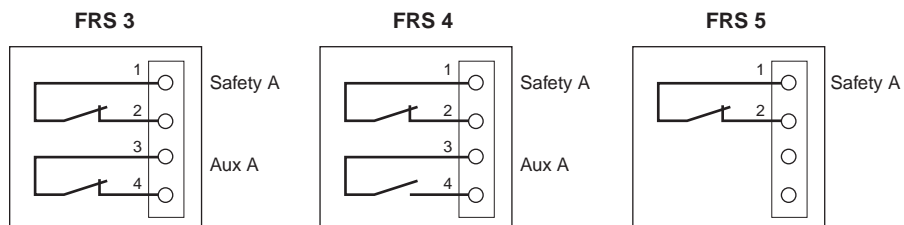

## Safety Switches

### Non-Contact Switches

#### Ferrogard™ 6, 9, 10, 13 & 14

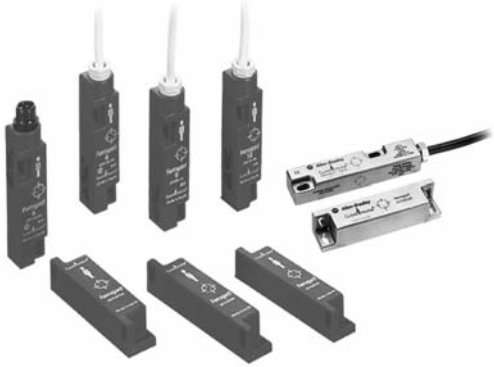

#### Description

The Ferrogard range of magnetically actuated safety switches offers non-contact reliability together with tolerance to misalignment. They are designed to be installed so that when a guard door is opened, the action of the magnetic actuator being removed from the switch opens the N.C. safety contact which is intended for the isolation of control power to a machine primary control element.

The FRS 6, 9, 10, 13, and 14 sensors and actuators incorporate slim housings to accommodate narrow mounting areas. They are environmentally sealed to IP67 (NEMA 6P), which makes them ideal for wet environments. These Ferrogard switches have two active sensing faces allowing more flexible mounting options.

Unlike some magnetic switches the Ferrogards have protected safety contacts to help ensure that they do not fail to danger.

All Ferrogards have internal non-resettable overload protection on the safety contact. They should be protected by an external fuse rated as shown in the Specifications table.

#### Features

- Non-contact actuation
- High tolerance to misalignment
- High switching current (up to 3 A)
- Two sensing faces
- IP67 (NEMA 6P) Rating
- Slim housings
- Stainless steel models available

3-Interlock  
Switches

#### Specifications

Safety Ratings		
Standards	EN954-1, ISO13849-1, IEC/EN60204-1, NFPA79, EN1088, ISO14119, ANSI B11.19, AS4024.1	
Safety Classification	Cat. 1 Device per EN954-1 Dual channel interlocks suitable for Cat. 3 or 4 systems	
Functional Safety Data *	B10d: > 2 x 10 <sup>6</sup> operations at min. PFH <sub>D</sub> : > 3 x 10 <sup>-7</sup> MTTFd: > 385 years Dual channel interlock may be suitable for performance levels PLe or PLd (according to ISO 13849-1:2006) and for use in SIL2 or SIL3 systems (according to IEC 62061) depending on application characteristics	
Certifications	CE Marked for all applicable directives and cULus	
Outputs (Guard Door Closed, Actuator in Place)		
Safety Outputs	1 N.C.	1 N.C.
Auxiliary Outputs	—	1 N.C.
Operating Characteristics		
Operating Distance, Make [mm (in.)]	12 (0.47)	
Operating Distance, Break [mm (in.)]	23 (0.91)	
Environmental		
Enclosure Type Rating	IP67 (NEMA 6P)	
Operating Temperature [C (F)]	-10...+65° (+14...+149°)	
Relative Humidity	5...95%	
Shock	IEC 68-2-27, 30 g, 11 ms	
Vibration	IEC 68-2-6, 10...55 Hz	
Radio Frequency	IEC 61000-4-3, IEC 61000-4-6	
Physical Characteristics		
Actuator/Housing Material	Molded ABS plastic	
Weight [g (lb)]	Sensor/Actuator FRS 6—28 (0.06)/70 (0.15) FRS 9—28 (0.06)/70 (0.15) FRS 10—28 (0.06)/70 (0.15)	
Color	Red	

\* Usable for ISO 13849-1:2006 and IEC 62061. Data other than B10d is based on:  
 - Usage rate of 1op/10 mins., 24 hrs/day, 360 days/year, representing 51840 operations per year  
 - Mission time/Proof test interval of 38 years

## Safety Switches

# Non-Contact Switches

### Ferrogard™ 6, 9, 10, 13 & 14

#### Product Selection

Safety Contact Switching Capability	Safety Contacts	Auxiliary Contacts	Housing Material	Type	Connection	Cat. No.
250V AC, 2 A	1 N.C.	—	Red Molded ABS Plastic	FRS 6	2 m Cable	<b>440N-G02023</b>
					4 m Cable	440N-G02028
					6 m Cable	440N-G02032
					10 m Cable	440N-G02013
					4-Pin Micro QD	440N-G02095
24V DC, 1 A		FRS 9	2 m Cable	<b>440N-G02044</b>		
			4 m Cable	440N-G02075		
			6 m Cable	440N-G02082		
			10 m Cable	440N-G02089		
110V AC, 3 A		FRS 10	2 m Cable	440N-G02045		
	4 m Cable		440N-G02088			
250V AC, 2 A	1 N.C.	—	Stainless Steel	FRS 13	2 m Cable	440N-G02154
					4 m Cable	440N-G02155
					4-Pin Micro QD	440N-G02160
24V DC, 1 A		FRS 14	2 m Cable	440N-G02156		
			4 m Cable	440N-G02157		
			4-Pin Micro QD	440N-G02161		

**Note:** Contacts are described with the guard door closed, that is, actuator in place.

#### Recommended Logic Interfaces

Description	Safety Outputs	Auxiliary Outputs	Terminals	Reset Type	Power Supply	Cat. Page No.	Cat. No.
<b>Single-Function Safety Relays</b>							
MSR127RP	3 N.O.	1 N.C.	Removable (Screw)	Monitored Manual	24V AC/DC	5-26	<b>440R-N23135</b>
MSR127TP	3 N.O.	1 N.C.	Removable (Screw)	Auto./Manual	24V AC/DC	5-26	<b>440R-N23132</b>
MSR126T	2 N.O.	None	Fixed	Auto./Manual	24V AC/DC	5-24	<b>440R-N23117</b>
MSR30T	2 N.O. Solid State	1 N.O. Solid State	Removable	Auto./Manual or Monitored Manual	24V DC	5-16	440R-N23198
<b>Modular Safety Relays</b>							
MSR210P Base 2 N.C. only	2 N.O.	1 N.C. and 2 PNP Solid State	Removable	Auto./Manual or Monitored Manual	24V DC from the base unit	5-82	440R-H23176
MSR220P Input Module	—	—	Removable	—	24V DC	5-86	440R-H23178
MSR310P Base	MSR300 Series Output Modules	3 PNP Solid State	Removable	Auto./Manual Monitored Manual	24V DC	5-102	440R-W23219
MSR320P Input Module	—	2 PNP Solid State	Removable	—	24V DC from the base unit	5-106	440R-W23218

**Note:** For additional Safety Relays connectivity, see page 5-12.  
For additional Safety I/O and Safety PLC connectivity, see page 5-116.  
For application and wiring diagrams, see page 10-1.

#### Connection Systems

Description	4-Pin Micro (M12)
Cordset	889D-F4AC-*
Patchcord	889D-F4ACDM-*

\* Replace symbol with 2 (2 m), 5 (5 m), or 10 (10 m) for standard cable lengths.

\* Replace symbol with 1 (1 m), 2 (2 m), 3 (3 m), 5 (5 m), or 10 (10 m) for standard cable lengths.

**Note:** For additional information, see page 7-1.

#### Accessories

Description	Cat. No.
FRS 6, 9, 10 Plastic Replacement Actuator	440N-A02025
FRS 13, 14 Stainless Steel Replacement Actuator	440N-A02165

**3-Interlock Switches**

## Safety Switches

### Non-Contact Switches

#### Ferrogard™ 6, 9, 10, 13 & 14

#### Approximate Dimensions

Dimensions are shown in mm (in.). Dimensions are not intended to be used for installation purposes.

#### FRS 6, 9, 10

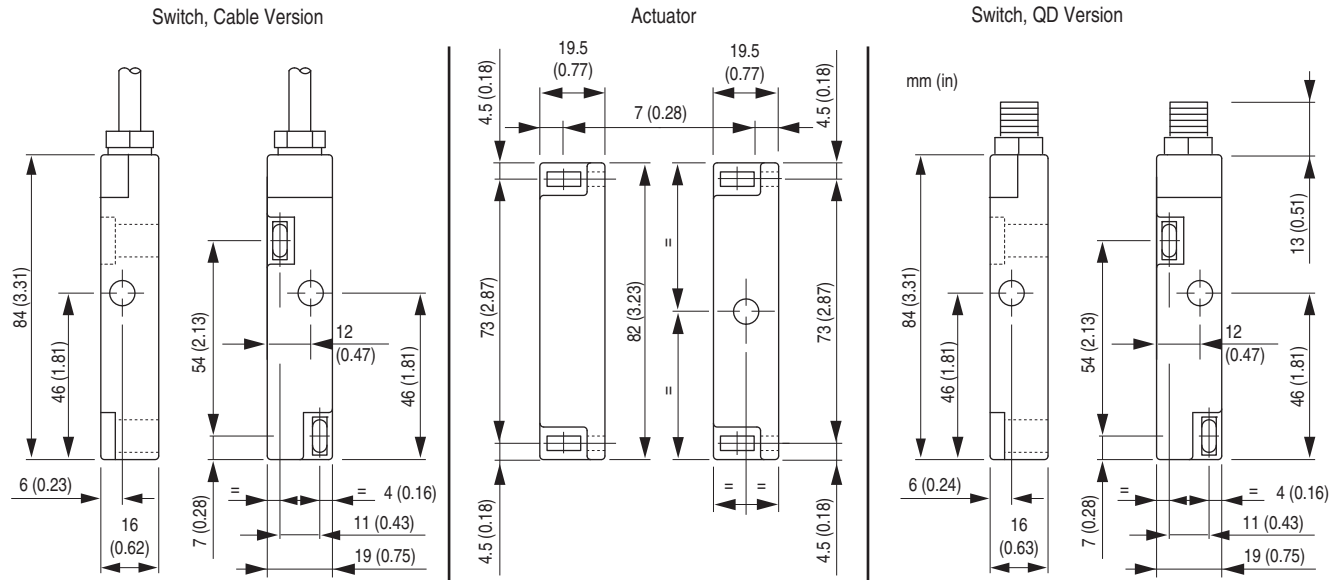

#### FRS 13, 14

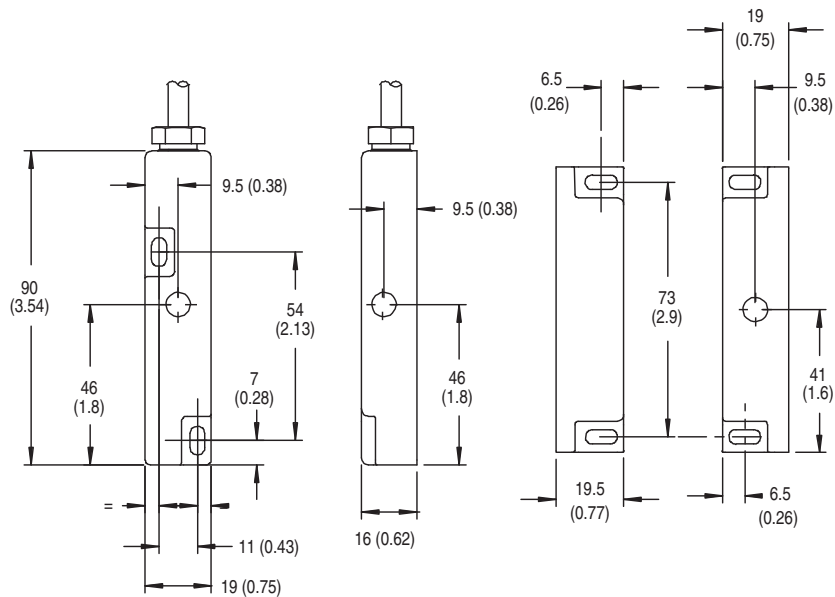

3-Interlock Switches

## Safety Switches Non-Contact Switches Ferrogard™ 6, 9, 10, 13 & 14

### Typical Wiring Diagrams

		FRS 6, 9, 10 1 N.C.	FRS 13, 14 1 N.C. + 1 N.O.
4-Pin Micro (M12)			
Cordset 889D-F4AC-*	Brown	Safety A	Safety A
	Blue	—	Aux A
	White	—	—
	Black	—	—
Cable Version	Safety A	Brown	Brown
		Blue	Blue
	Aux A	—	Black
			Grey

\* Replace symbol with 2 (2 m), 5 (5 m) or 10 (10 m) for standard cable lengths.

### External Fuse Safety Contacts



**WARNING:** All safety contacts fitted with internal non-resettable fuse and must be fused externally as detailed.

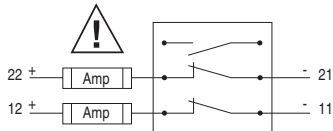

Recommended:  
\*Bussman BK/GDA-1.6 A  
\*\* Bussman BK/GDA-400 mA  
\*\*\*Bussman BK/GDA-2.5 A

FRS 1, 2, 3, 4, 5, 6, 13, 21 AC	AC ≤ 1.6 A* (F) IEC 60127-2
FRS 9, 14, 2 DC, 20 DC, 21 DC	DC ≤ 0.4 A** (F) IEC 60127-2
FRS 10	AC ≤ 2.5 A*** (F) IEC 60127-2

3-Interlock  
Switches

## Safety Switches

### Non-Contact Switches

#### Ferrogard™ GD2



#### Description

The Ferrogard range of magnetically actuated safety switches offers non-contact reliability together with tolerance to misalignment. They are designed to be installed so that when a guard door is opened, the action of the magnetic actuator being removed from the switch opens the N.C. safety contacts which are intended for the isolation of control power to a machine primary control element.

The GD2 version has a stainless steel housing for added protection against inadvertent impacts to the housing. The contacts are completely sealed to meet IP68 (NEMA 6P) requirements, making them ideal for wet environments. The GD2 also has a wider temperature range than the plastic Ferrogard switches, making them useful in a wider range of applications.

Unlike some magnetic switches, the Ferrogards have protected safety contacts to help ensure that they do not fail to danger. In addition, some versions have independent auxiliary signal contacts to indicate the machine and guard condition.

All Ferrogards have internal non-resettable overload protection on the safety contact. They should be protected by an external fuse rated as shown in the Specifications table.

#### Features

- Non-contact actuation
- High tolerance to misalignment
- High switching current (up to 2 A AC, 1 A DC)
- Wide temperature range (-25...+125°C (-13...+257°F))
- Stainless steel housing
- Various contact arrangements

#### Specifications

Safety Ratings	
Standards	EN954-1, ISO13849-1, IEC/EN60204-1, NFPA79, EN1088, ISO14119, ANSI B11.19, AS4024.1
Safety Classification	Cat. 1 Device per EN954-1 Dual channel interlocks suitable for Cat. 3 or 4 systems
Functional Safety Data *	B10d: > 2 x 10 <sup>6</sup> operations at min. PFH <sub>D</sub> : > 3 x 10 <sup>-7</sup> MTTFd: > 385 years Dual channel interlock may be suitable for performance levels PLe or PLd (according to ISO 13849-1:2006) and for use in SIL2 or SIL3 systems (according to IEC 62061) depending on application characteristics
Note:	For up-to-date information, visit <a href="http://www.ab.com/Safety/">http://www.ab.com/Safety/</a>
Certifications	CE Marked for all applicable directives and cULus

#### Outputs (Guard Door Closed, Actuator in Place)

Safety Outputs	1 N.C.	2 N.C.	2 N.C.
Auxiliary Outputs	1 N.O.	—	1 N.O.

#### Operating Characteristics

Operating Distance, Make [mm (in.)]	Safety: 12 (0.47); Auxiliary: 15 (0.59)
Operating Distance, Break [mm (in.)]	Safety: 23 (0.91); Auxiliary: 26 (1.02)

#### Environmental

Enclosure Type Rating	IP68 (NEMA 6P)
Operating Temperature [C (F)]	-25...+125° (-13...+257°)
Relative Humidity	5...95%
Shock	IEC 68-2-27, 30 g, 11 ms
Vibration	IEC 68-2-6, 10...200 Hz
Radio Frequency	IEC 61000-4-3, IEC 61000-4-6

#### Physical Characteristics

Housing Material	Stainless Steel; BS3146 ANC4B (316L)
Actuator Material	Stainless Steel; BS3146 ANC4B (316L)
Weight [g (lbs)]	Sensor: 156 (0.34); Actuator: 168 (0.37)

- \* Usable for ISO 13849-1:2006 and IEC 62061. Data other than B10d is based on:
- Usage rate of 1op/10 mins., 24 hrs/day, 360 days/year, representing 51840 operations per year
  - Mission time/Proof test interval of 38 years



## Safety Switches

# Non-Contact Switches

### Ferrogard™ GD2

#### Product Selection

Safety Contact Switching Capability	Safety Contacts	Auxiliary Contacts	Connection	Type	Cat. No.
250V AC, 2 A max.	2 N.C.	—	3 m Cable	FRS 20 GD2	440N-G02113
	1 N.C.	1 N.O.	3 m Cable	FRS 2 GD2	440N-G02112
	2 N.C.		3 m Cable	FRS 21 GD2	440N-G02117
24V DC, 1 A max.	1 N.C.	1 N.O.	3 m Cable	FRS 2 GD2	440N-G02118
			10 m Cable	FRS 2 GD2	440N-G02147
	2 N.C.	—	3 m Cable	FRS 20 GD2	440N-G02119
	2 N.C.	1 N.O.	3 m Cable	FRS 21 GD2	<b>440N-G02123</b>
			6 m Cable	FRS 21 GD2	440N-G02143
			10 m Cable	FRS 21 GD2	440N-G02137
			8-Pin Micro (M12)	FRS 21 GD2	<b>440N-G02149</b>

**Note:** Contacts are described with the guard door closed, that is, actuator in place. Switch is shipped with complete actuator.

#### Recommended Logic Interfaces

Description	Safety Outputs	Auxiliary Outputs	Terminals	Reset Type	Power Supply	Cat. Page No.	Cat. No.
<b>Single-Function Safety Relays</b>							
MSR127RP	3 N.O.	1 N.C.	Removable (Screw)	Monitored Manual	24V AC/DC	5-26	<b>440R-N23135</b>
MSR127TP	3 N.O.	1 N.C.	Removable (Screw)	Auto./Manual	24V AC/DC	5-26	<b>440R-N23132</b>
MSR126T	2 N.O.	None	Fixed	Auto./Manual	24V AC/DC	5-24	<b>440R-N23117</b>
MSR30T	2 N.O. Solid State	1 N.O. Solid State	Removable	Auto./Manual or Monitored Manual	24V DC	5-16	440R-N23198
<b>Modular Safety Relays</b>							
MSR210P Base 2 N.C. only	2 N.O.	1 N.C. and 2 PNP Solid State	Removable	Auto./Manual or Monitored Manual	24V DC from the base unit	5-82	440R-H23176
MSR220P Input Module	—	—	Removable	—	24V DC	5-86	440R-H23178
MSR310P Base	MSR300 Series Output Modules	3 PNP Solid State	Removable	Auto./Manual Monitored Manual	24V DC	5-102	440R-W23219
MSR320P Input Module	—	2 PNP Solid State	Removable	—	24V DC from the base unit	5-106	440R-W23218

**Note:** For additional Safety Relays connectivity, see page 5-12.  
For additional Safety I/O and Safety PLC connectivity, see page 5-116.  
For application and wiring diagrams, see page 10-1.

**3-Interlock Switches**

#### Connection Systems

Description	8-Pin Micro (M12)
Cordset	889D-F8AB-*
Patchcord	889D-F8ABDM-*

\* Replace symbol with 2 (2 m), 5 (5 m), or 10 (10 m) for standard cable lengths.  
\* Replace symbol with 1 (1 m), 2 (2 m), 3 (3 m), 5 (5 m), or 10 (10 m) for standard cable lengths.

**Note:** For additional information, see page 7-1.

#### Accessories

Description	Cat. No.
Actuator	440N-A02128

# Safety Switches

## Non-Contact Switches

### Ferrogard™ GD2

#### Approximate Dimensions

Dimensions are shown in mm (in.). Dimensions are not intended to be used for installation purposes.

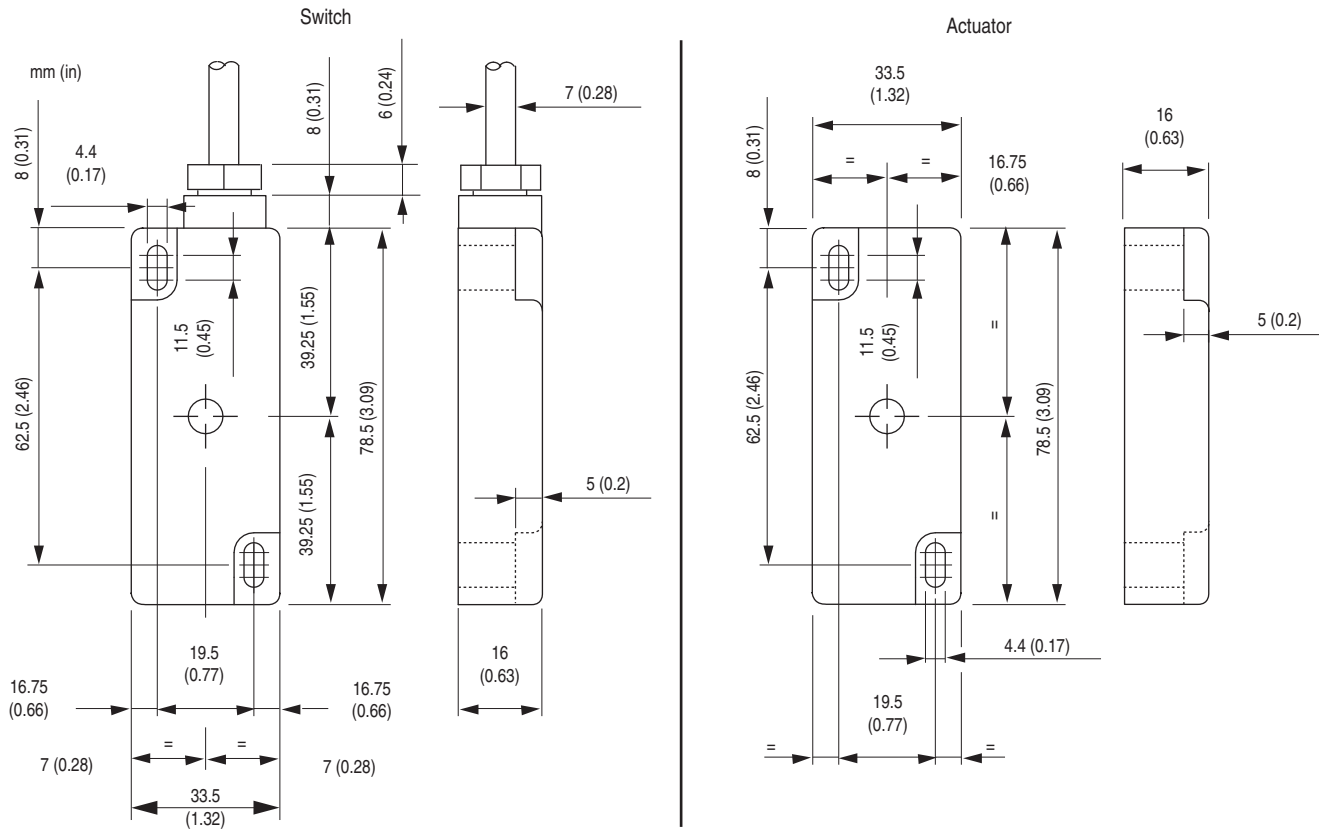

3-Interlock Switches

## Safety Switches Non-Contact Switches Ferrogard™ GD2

### Typical Wiring Diagrams

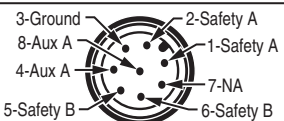
Description		FRS21	FRS2	FRS20
		2 N.C. + 1 N.O.	1 N.C. + 1 N.O.	2 N.C.
Cable Versions	Safety A	Black	Blue	Brown
		White	Red	Blue
	Safety B	Red	—	Black
		Blue	—	White
	Aux A	Yellow	Yellow	—
Green		Green	—	
Shield Gnd	—	Green/Yellow	Green/Yellow	
8-Pin Micro (M12)			—	—
Cordset 889D-F8AB-*	Brown White	Safety A	—	—
	Grey Pink	Safety B	—	—
	Yellow Red	Safety B	—	—
	Green Blue	NA	—	—

\* Replace symbol with 2 (2 m), 5 (5 m) or 10 (10 m) for standard cable lengths.

### External Fuse Safety Contacts



**WARNING:** All safety contacts fitted with internal non-resettable fuse and must be fused externally as detailed.

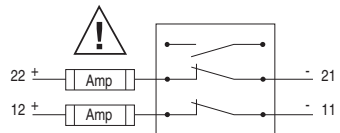

FRS 2 GD2 FRS20 GD2 FRS21 GD2	AC ≤ 1.6 A* (F) IEC 60127-2
FRS 2 GD2 FRS 20 GD2 FRS21 GD2	DC ≤ 0.4 A** (F) IEC 60127-2

Recommended:  
\*Bussman BK/GDA-1.6 A  
\*\* Bussman BK/GDA-400 mA

3-Interlock  
Switches

## Safety Switches

### Non-Contact Switches

#### Ferrogard™ GS1 & GS2



#### Description

The Ferrogard range of magnetically actuated safety switches offers non-contact reliability together with tolerance to misalignment. They are designed to be installed so that when a guard door is opened, the action of the magnetic actuator being removed from the switch opens the N.C. safety contacts which are intended for the isolation of control power to a machine primary control element.

The GS1 and GS2 are designed for heavy duty applications. The GS1 is housed in a stainless steel or brass housing. The GS2 offers the same characteristic as the GS1, but in an Ex Range housing for hazardous locations.

Unlike some magnetic switches the Ferrogards have protected safety contacts to help ensure that they do not fail to danger.

All Ferrogards have internal non-resettable overload protection on the safety contact. They should be protected by an external fuse rated as shown in the Specifications table.

See **Other Safety Products** section on page 9-1 for more information on the Ex Range version of the Ferrogard GS2.

#### Features

- Non-contact actuation
- High tolerance to misalignment
- High switching current (2 A AC)
- Metal housings (IP68)
- Ex Range version available

3-Interlock  
Switches

#### Specifications

Safety Ratings	
Standards	EN954-1, ISO13849-1, IEC/EN60204-1, NFPA79, EN1088, ISO14119, ANSI B11.19, AS4024.1
Safety Classification	Cat. 1 Device per EN954-1 Dual channel interlocks suitable for Cat. 3 or 4 systems
Functional Safety Data *	B10d: > 2 x 10 <sup>6</sup> operations at min. PFH <sub>D</sub> : > 3 x 10 <sup>-7</sup> MTTFd: > 385 years Dual channel interlock may be suitable for performance levels PLe or PLd (according to ISO 13849-1:2006) and for use in SIL2 or SIL3 systems (according to IEC 62061) depending on application characteristics
Certifications	GS1 & GS2 - CE Marked for all applicable directives and cULus GS2 Ex - EExd IIC T6 Baseefa
Outputs (Guard Door Closed, Actuator in Place)	
Safety Outputs	1 N.C.
Auxiliary Outputs	—
Operating Characteristics	
Operating Distance, Make [mm (in.)]	GS1: 12 (0.47); GS2: 15 (0.59)
Operating Distance, Break [mm (in.)]	GS1: 23 (0.91); GS2: 26 (1.02)
Environmental	
Enclosure Type Rating	IP68 (NEMA 6P)
Operating Temperature [C (F)]	GS1: -25...+125° (-13...+257°) GS2: -40...+60° (-40...146°)
Relative Humidity	5...95%
Shock	IEC 68-2-27, 30 g, 11 ms
Vibration	IEC 68-2-6, 10...55 Hz
Radio Frequency	IEC 61000-4-3, IEC 61000-4-6
Physical Characteristics	
Housing Material	Stainless Steel or Brass
Weight [g (lbs)]	GS1 Brass: 381 (0.84) GS1 Steel: 388 (0.86) Actuator: 116 (0.26)

\* Usable for ISO 13849-1:2006 and IEC 62061. Data other than B10d is based on:  
- Usage rate of 1op/10 mins., 24 hrs/day, 360 days/year, representing 51840 operations per year  
- Mission time/Proof test interval of 38 years

## Safety Switches Non-Contact Switches Ferrogard™ GS1 & GS2

### Product Selection

Safety Contact Switching Capability	Safety Contacts	Auxiliary Contacts	Connection	Housing Material	Type	Cat. No.
250V AC, 2 A	1 N.C.	None	2 m Cable	Brass	GS 1	440N-G02048
				Stainless Steel		440N-G02049
			3 m Cable	Brass	GS2-Ex (brass)	440N-H02046
				Stainless Steel	GS2-Ex (stainless steel)	440N-H02047

**Note:** Contacts are described with the guard door closed, that is, actuator in place. Switch is shipped with complete actuator.

### Recommended Logic Interfaces

Description	Safety Outputs	Auxiliary Outputs	Terminals	Reset Type	Power Supply	Cat. Page No.	Cat. No.
<b>Single-Function Safety Relays</b>							
MSR127RP	3 N.O.	1 N.C.	Removable (Screw)	Monitored Manual	24V AC/DC	5-26	<b>440R-N23135</b>
MSR127TP	3 N.O.	1 N.C.	Removable (Screw)	Auto./Manual	24V AC/DC	5-26	<b>440R-N23132</b>
MSR126T	2 N.O.	None	Fixed	Auto./Manual	24V AC/DC	5-24	<b>440R-N23117</b>
MSR30T	2 N.O. Solid State	1 N.O. Solid State	Removable	Auto./Manual or Monitored Manual	24V DC	5-16	440R-N23198
<b>Modular Safety Relays</b>							
MSR210P Base 2 N.C. only	2 N.O.	1 N.C. and 2 PNP Solid State	Removable	Auto./Manual or Monitored Manual	24V DC from the base unit	5-82	440R-H23176
MSR220P Input Module	—	—	Removable	—	24V DC	5-86	440R-H23178
MSR310P Base	MSR300 Series Output Modules	3 PNP Solid State	Removable	Auto./Manual Monitored Manual	24V DC	5-102	440R-W23219
MSR320P Input Module	—	2 PNP Solid State	Removable	—	24V DC from the base unit	5-106	440R-W23218

**Note:** For additional Safety Relays connectivity, see page 5-12.  
For additional Safety I/O and Safety PLC connectivity, see page 5-116.  
For application and wiring diagrams, see page 10-1.

### Accessories

Description	Used with	Cat. No.
Actuator, Alnico	Brass Switch	440N-A02056
Actuator, Epoxy-painted	Stainless Steel	440N-A02057

### Approximate Dimensions

Dimensions are shown in mm (in.). Dimensions are not intended to be used for installation purposes.

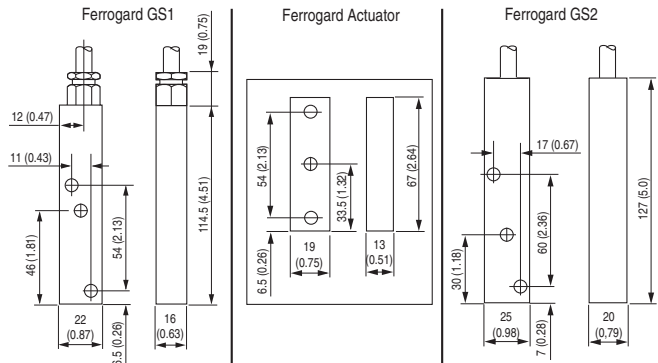

### Typical Wiring Diagrams

#### Cable



### External Fuse Safety Contacts



**WARNING:** All safety contacts fitted with internal non-resettable fuse and must be fused externally as detailed.

GS1	AC ≤ 1.6 A* (F) IEC 60127-2
GS2	

Recommended:  
\*Bussman BK/GDA-1.6 A

**3-Interlock Switches**

## Safety Switches

### Non-Contact Switches

#### Sipha™ Sensors



#### Description

With the increasing speed and complexity of applications a simple magnetic switch may be insufficient to meet the increased risks, therefore Sipha's design incorporates several magnetically sensitive elements which must be triggered in a particular sequence to operate correctly. The Sipha sensor, designed to operate with its own actuator, helps prevent defeatability by a simple magnet.

The Sipha with its molded-in brackets and diminutive size, is extremely versatile and simple to install. The Sipha sensor must be connected to the Sipha control unit giving a monitored circuit. For high-risk applications the control unit is used with a single sensor to give a high-integrity system. For other applications, multiple sensors (including mechanical switches) can be connected to one Sipha control unit. Sipha has facilities for connecting a manual reset button and for monitoring external devices such as contactors.

Four types of sensors and actuators are available incorporating different operating distances and physical sizes.

#### Features

- Non-contact actuation
- Magnetic coded sensing
- Four housing styles
- Must be operated with its own safety control unit





3-Interlock  
Switches

#### Specifications

Safety Ratings	
Standards	EN954-1, ISO13849-1, IEC/EN60204-1, NFPA79, EN1088, ISO14119, IEC60947-5-1, IEC/EN60947-5-3, ANSI B11.19, AS4024.1
Safety Classification	Rating dependent on control unit and application.
Functional Safety Data	B10d: > 2 x 10 <sup>6</sup> operations at min. PFH <sub>D</sub> : > 3 x 10 <sup>-7</sup> MTTFd: > 385 years Dual channel interlock may be suitable for performance levels PLe or PLd (according to ISO 13849-1:2006) and for use in SIL2 or SIL3 systems (according to IEC 62061) depending on application characteristics
Note: For up-to-date information, visit <a href="http://www.ab.com/Safety/">http://www.ab.com/Safety/</a>	
Certifications	CE Marked for all applicable directives, cULus, and TÜV
Outputs (Guard Door Closed, Actuator in Place)	
Auxiliary Output Switching	300V DC, 250V AC, 0.5 A including inrush. 15V A/10 W suitable for AC/DC circuits
Operating Characteristics	
Sensing Distance, Make [mm (in.)]	Style S1: 5 (0.20) Style S2: 9 (0.35) Style S3: 5 (0.20) Style S4: 10 (0.39)
Sensing Distance, Break [mm (in.)]	Style S1: 11 (0.43) Style S2: 12 (0.47) Style S3: 12 (0.47) Style S4: 13 (0.51)
Environmental	
Enclosure Type Rating	IP67 (NEMA 6P)
Operating Temperature [C (F)]	S1, S2, S3: -10...+55° (+14...+131°) S4 (GD2): -25...+125° (-13...+257°)
Vibration	1 mm, 10...55 Hz
Shock	30 g, 11 ms half-sine
Physical Characteristics	
Cable Size	0.54 mm <sup>2</sup> (20 AWG) 4-wire PVC Jacket OD—4 mm (0.16 in.)
Material	S1, S2: Molded ABS S30 (Actuator): Polyester S31 (Sensor): Nylon (Trogamid) S4 (GD2): Stainless Steel
Mounting	Any position
Weight [g (lbs)]	S1: Sensor: 18 (0.04); Actuator: 15 (0.03) S2: Sensor: 20 (0.04); Actuator: 30 (0.07) S3: Sensor: 18 (0.04) Actuator: 6 (0.01) S4: Sensor: 150 (0.33); Actuator: 170 (0.37)

## Safety Switches Non-Contact Switches Sipha™ Sensors

### Product Selection

Housing Style	Housing Material	Safety Contacts	Auxiliary Contacts	Type	Connection	Cat. No.
 S1	ABS plastic	1 N.C. & 1 N.O.	None	S11	3 m Cable	<b>440N-S32014</b>
					10 m Cable	440N-S32016
			1 N.C.	S12	3 m Cable	440N-S32022
					10 m Cable	440N-S32032
			1 N.O.	S13	3 m Cable	440N-S32037
					10 m Cable	440N-S32036
 S2	ABS plastic		None	S21	3 m Cable	440N-S32015
					10 m Cable	440N-S32017
			1 N.C.	S22	3 m Cable	440N-S32023
					10 m Cable	440N-S32033
			1 N.O.	S23	3 m Cable	440N-S32038
					10 m Cable	440N-S32039
 S3	Actuator: Polyester Sensor: Nylon [Trogamid]	None	S31	3 m Cable	440N-S32101	
					4-Pin Micro (M12)	440N-S32024
 S4	Stainless Steel	1 N.C.	S42	8-Pin Micro (M12)	<b>440N-S32047</b>	
					3 m Cable	440N-S32055
				10 m Cable	440N-S32056	
		1 N.O.	S43	8-Pin Micro (M12)	440N-S32046	
					3 m Cable	440N-S32053
					10 m Cable	440N-S32054

### Recommended Logic Interfaces

Housing	Supply Voltage	Safety Contacts	Auxiliary Contacts	Housing Width	Type	Cat. Page No.	Cat. No.
	24V AC/DC	1 N.O.	1 N.C. Solid State	22.5 mm	Control Unit 1	5-74	440N-S32013
	24V AC/DC; 115/230V AC	2 N.O.	1 N.C.	45 mm	Control Unit 2		440N-S32021
	24V AC/DC; 115/230V AC	2 N.O. + 1 N.O. delayed	1 N.C.	90 mm	Sipha 6		440N-S32052

3-Interlock Switches

### Connection Systems

Description	4-Pin Micro (M12)	8-Pin Micro (M12)
Cordset	889D-F4ECA-*	889D-F8AB-*
Patchcord	889D-F4ECRM-*	889D-F8ABDM-*

\* Replace symbol with 2 (2 m), 5 (5 m), or 10 (10 m) for standard cable lengths.  
 \* Replace symbol with 1 (1 m), 2 (2 m), 3 (3 m), 5 (5 m), or 10 (10 m) for standard cable lengths.  
**Note:** For additional information, see page 7-1.

# Safety Switches

## Non-Contact Switches

### Sipha™ Sensors

#### Approximate Dimensions

Dimensions are shown in mm (in.). Dimensions are not intended to be used for installation purposes.

#### Sipha S1

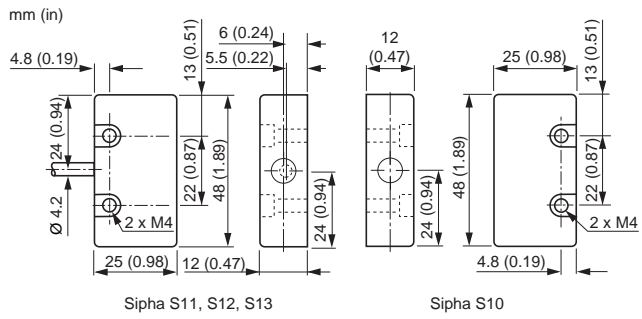

#### Sipha S2

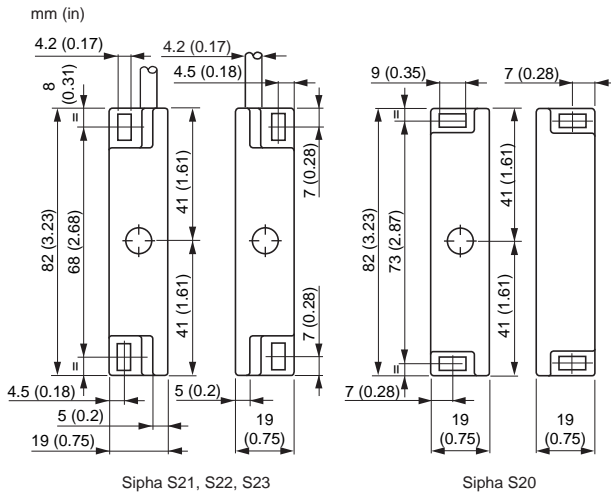

#### Sipha S3

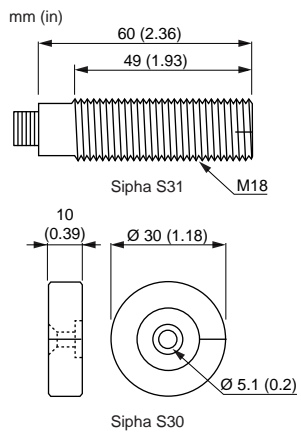

#### Sipha S4

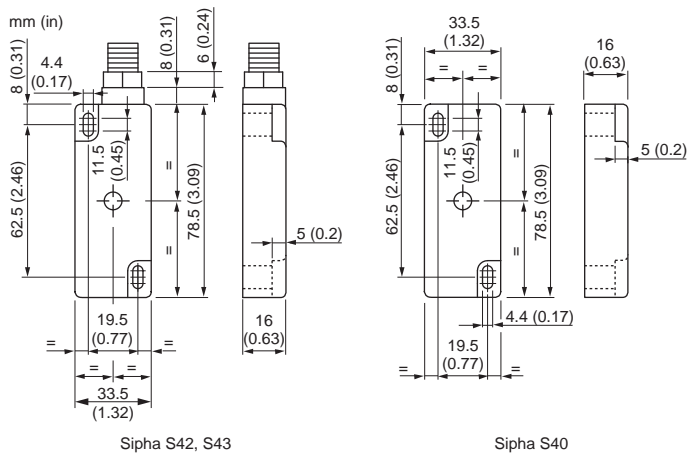

3-Interlock Switches

#### Accessories

Description	Cat. No.
Actuator S10	440N-A32019
Actuator S20	440N-A32020
Actuator S30	440N-A32025
Actuator S40 (GD2)	440N-A32041
Bag of 40 washers for S2 models	440N-A17127



## Safety Switches Non-Contact Switches Sipha™ Sensors

### Typical Wiring Diagrams

Description		S11, S21	S42, S12, S22	S43, S13, S23
		1 N.O. + 1 N.C.	2 N.C. + 1 N.O.	1 N.C. + 2 N.O.
Cable Versions	Red	Safety A_N.C.	Safety A_N.C.	Safety A_N.C.
	Blue			
	Yellow			
	Green	Safety B_N.O.	Safety B_N.O.	Safety B_N.O.
	Black	—	Aux A_N.C.	Aux A_N.O.
	White	—	External Ground	External Ground
	Green/Yellow	—	External Ground	External Ground

Description		S31	S42	S43
4-Pin Micro (M12)			—	—
8-Pin Micro (M12)		—		
4-Pin Cordset 889D-F4AC-*	Brown	Safety A_N.C.	—	—
	Blue			
	White	Safety B_N.O.	—	—
	Black			
8-Pin Cordset 889D-F8AB-*	White Brown	Safety A	Safety A_N.C.	Safety A_N.C.
	Red Yellow	Safety B	Safety B_N.O.	Safety B_N.O.
	Grey Pink	Aux A	Aux A_N.C.	Aux A_N.O.
	Green Blue	NA	Gnd	Gnd

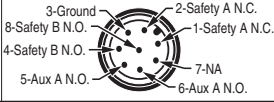
\* Replace symbol with 2 (2 m), 5 (5 m) or 10 (10 m) for standard cable lengths.

**3-Interlock  
Switches**

# Interlock Switches

## Hinge Switches

### Sprite™



#### Description

The Sprite is a hinge-actuated safety interlock switch in a compact housing—only 75 x 25 x 29 mm (2.95 x 0.98 x 1.14 in.)—making it the smallest interlock currently available. The Sprite has been designed for smaller machines such as printing machines, copiers and domestic machinery, which until now, have been able to use standard safety interlocks due to space restrictions. Despite its small size, the Sprite includes the necessary safety-related functions, such as forced-guided contacts and a tamper-resistant mechanism allowing machinery to be safeguarded in compliance with the machinery directive.

The shaft of the Sprite is connected to the existing hinge pin and the degree of operation can be adjusted to suit the application via the adjustable cam in the switch head.

3-Interlock Switches



**IMPORTANT:** After adjustment, the cam must be secured in position with the supplied cam locking pin to ensure optimal performance.

#### Features

- Ideal for small, light-weight guards
- The smallest hinge interlock switch available, 75 x 25 mm case
- Degree of operation can customized with adjustable cam
- Contacts, 2 N.C. or 1 N.C. & 1 N.O.
- Four possible shaft positions, easy to install

#### Specifications

Safety Ratings	
Standards	EN954-1, ISO13849-1, IEC/EN60204-1, NFPA79, EN1088, ISO14119, IEC/EN60947-5-1, ANSI B11.19, AS4024.1
Safety Classification	Cat. 1 device per EN 954-1 May be suitable for use in Cat 3 or Cat 4 systems depending on the architecture and application characteristics
Functional Safety Data *	B10d: > 2 x 10 <sup>6</sup> operations at min. load PFH <sub>D</sub> : < 3 x 10 <sup>-7</sup> MTTFd: > 385 years May be suitable for use in performance levels Plc or Pld systems (according to ISO 13849-1:2006) and for use in SIL2 or SIL3 systems (according to IEC 62061) depending on the architecture and application characteristics
Note:	For up-to-date information, visit <a href="http://www.ab.com/Safety/">http://www.ab.com/Safety/</a>
Certifications	CE Marked for all applicable directives, cULus NRTL/C and TÜV
Outputs	
Safety Contacts *	2 N.C. direct-opening action   1 N.C. direct-opening action
Auxiliary Contacts	—   1 N.O.
Shaft Rotation for Contact Operation	Maximum 11°; Minimum 3° (adjustable)
Thermal Current I <sub>th</sub>	10 A
Rated Insulation Voltage	(Ui) 500V
Switching Current @ Voltage, Min.	5 mA @ 5V DC
Utilization Category	
A600/AC-15	(Ue) 600V   500V   240V   120V (Ie) 1.2 A   1.4 A   3 A   6 A
DC-13	(Ue) 24V         (Ie) 2 A
Operating Characteristics	
Break Contact Force, Min.	8 cNm (torque on shaft)
Actuation Speed, Max.	160 mm (6.29 in.)/s
Actuation Frequency, Max.	1 cycle/s
Operating Life @ 100 mA load	1,000,000 operations
Environmental	
Enclosure Type Rating	IP67
Operating Temperature [C (F)]	-20...+80° (-4...176°)
Physical Characteristics	
Housing Material	UL Approved glass-filled PBT
Shaft Material	Stainless Steel
Weight [g (lb)]	80 (0.176)
Color	Red

\* Usable for ISO 13849-1:2006 and IEC 62061. Data is based on the B10d value given and:  
 - Usage rate of 1op/10 mins., 24 hrs/day, 360 days/year, representing 51840 operations per year  
 - Mission time/Proof test interval of 38 years  
 \* The safety contacts are described as normally closed (N.C.) i.e., with the guard closed, actuator in place (where relevant) and the machine able to be started.

## Interlock Switches

# Hinge Switches

Sprite™

### Product Selection

Contact			Shaft Type	Actuator Shaft Dimensions—mm (in)	Cat. No.				
Safety	Auxiliary	Action			M16 Conduit		Connector§		
					M16	1/2 inch NPT Adaptor	4-Pin Micro (M12)	Connect to ArmorBlock Guard I/O 5-Pin Micro (M12)	
2 N.C.	—	—	Solid	80 x Ø10 (3.14 x 0.39)	440H-S34019	440H-S34023	440H-S34027	—	
				60 x Ø8 (2.36 x 0.31)	440H-S34020	440H-S34024	440H-S34028	—	
				50 x Ø10(1.96 x 0.39)	440H-S34010	440H-S34017	440H-S34014	440H-S2NNPPS	
1 N.C.	1 N.O.	BBM	Pre-Bored	30 x Ø16 (1.18 x 0.63) bore Ø9.5 (0.37)	440H-S34033	440H-S34034	440H-S34035	440H-S2NNHPS	
				Solid	80 x Ø10 (3.14 x 0.39)	440H-S34021	440H-S34025	440H-S34029	—
					60 x Ø8 (2.36 x 0.31)	440H-S34022	440H-S34026	440H-S34030	—
50 x Ø10(1.96 x 0.39)	440H-S34012	440H-S34018	440H-S34015	—					
			Pre-Bored	30 x Ø16 (1.18 x 0.63) bore Ø9.5 (0.37)	440H-S34036	—	—	—	

§ For connector ratings, see page 3-9.

### Recommended Logic Interfaces

Description	Safety Outputs	Auxiliary Outputs	Terminals	Reset Type	Power Supply	Cat. Page No.	Cat. No.
<b>Single-Function Safety Relays</b>							
MSR127RP	3 N.O.	1 N.C.	Removable (Screw)	Monitored Manual	24V AC/DC	5-26	440R-N23135
MSR127TP	3 N.O.	1 N.C.	Removable (Screw)	Auto./Manual	24V AC/DC	5-26	440R-N23132
MSR9T	2 N.O.	1 N.C.	Fixed	Auto./Manual	24V AC/DC	5-14	440R-F23027
MSR30RT	2 N.O. Solid State	1 N.O. Solid State	Removable	Auto./Manual or Monitored Manual	24V DC	5-16	440R-N23198
MSR33RT	2 N.O. Solid State	1 N.O.	Removable	Auto. or Monitored Manual	24V DC SELV	5-18	440R-F23200
<b>Modular Safety Relays</b>							
MSR210P Base 2 N.C. only	2 N.O.	1 N.C. and 2 PNP Solid State	Removable	Auto./Manual or Monitored Manual	24V DC from the base unit	5-82	440R-H23176
MSR220P Input Module	—	—	Removable	—	24V DC	5-86	440R-H23178
MSR310P Base	MSR300 Series Output Modules	3 PNP Solid State	Removable	Auto./Manual Monitored Manual	24V DC	5-102	440R-W23219
MSR320P Input Module	—	2 PNP Solid State	Removable	—	24V DC from the base unit	5-106	440R-W23218

**Note:** For additional Safety Relays connectivity, see page 5-12.  
 For additional Safety I/O and Safety PLC connectivity, see page 5-116.  
 For application and wiring diagrams, see page 10-1.

### Connection Systems

Description	4-Pin Micro (M12)		5-Pin Micro (M12) for ArmorBlock Guard I/O
	2 N.C.	1 N.C. & 1 N.O.	2 N.C.
Cordset	889D-F4AC-*	889D-F4AC-*	—
Patchcord	889D-F4ACDM-*	889D-F4ACDM-*	889D-F5ACDM-*
Distribution Box	889D-4†LT-DM4	898D-F4‡KT-DM4	—
Shorting Plug	889D-41LU-DM	898D-41KU-DM	—
T-Port	889D-43LY-D4	898D-43KY-D4	—

\* Replace symbol with 2 (2 m), 5 (5 m), or 10 (10 m) for standard cable lengths.  
 † Replace symbol with 1 (1 m), 2 (2 m), 3 (3 m), 5 (5 m), or 10 (10 m) for standard cable lengths.  
 ‡ Replace symbol with 4 or 8 for number of ports.

**Note:** For additional information, see the Safety Connection System section (page 7-1) of this catalog.

3-Interlock Switches

# Interlock Switches

## Hinge Switches

### Sprite™

#### Approximate Dimensions

Dimensions are shown in mm (in.). Dimensions are not intended to be used for installation purposes.

# = mm (in)

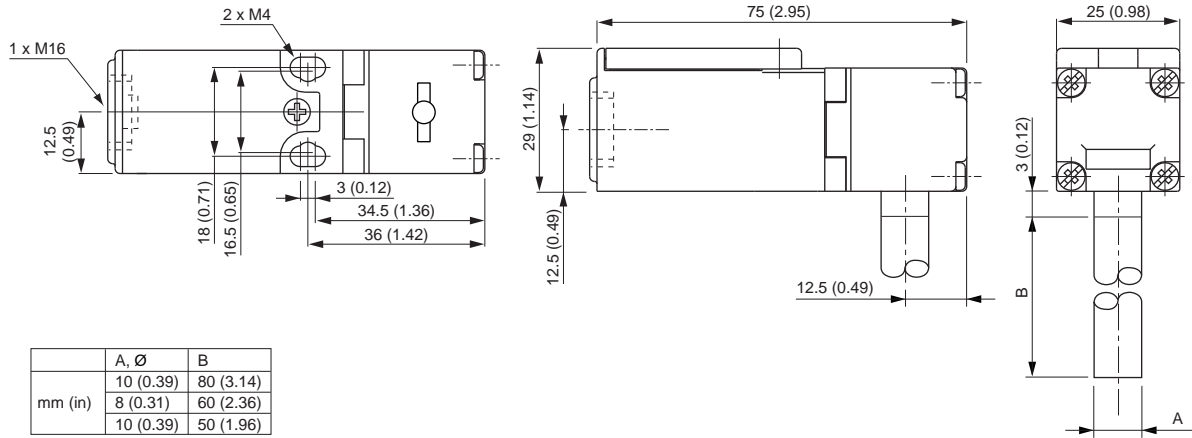

#### Hollow Shaft

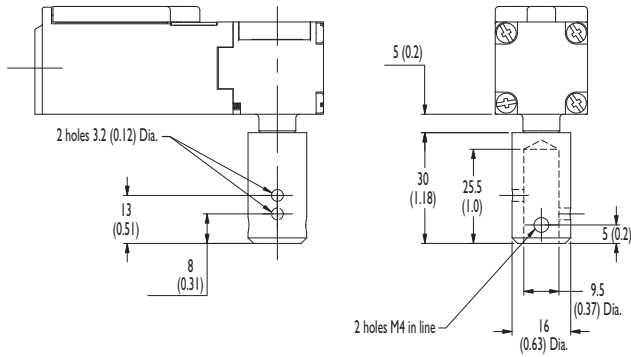



Note: 2D, 3D and electrical drawings are available on [www.ab.com](http://www.ab.com).

3-Interlock Switches

## Interlock Switches Hinge Switches Sprite™

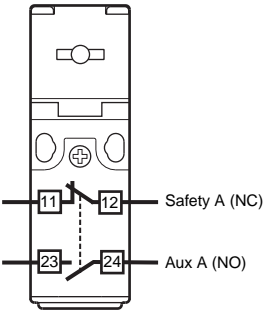
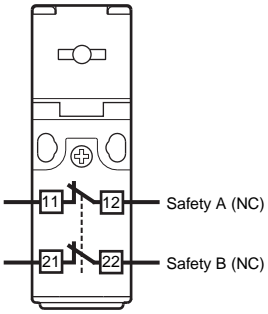
### Typical Wiring Diagrams

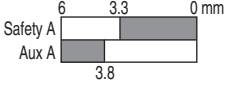
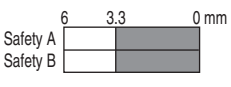
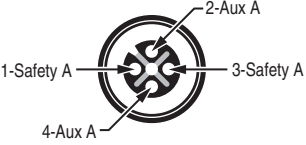
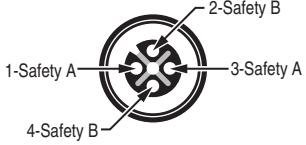
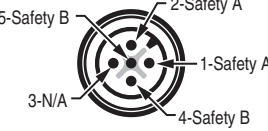
Description	1 N.C. & 1 N.O.	2 N.C.
Contact Configuration  		
Contact Action  		
4-Pin Micro (M12)		
5-Pin Micro (M12) For ArmorBlock Guard I/O	—	
Cordset 889D-F4AC-★	Brown	Safety A
	Blue	Safety A
	White	Aux A
	Black	Safety B

\* Replace symbol with 2 (2 m), 5 (5 m) or 10 (10 m) for standard cable lengths.

**3-Interlock  
Switches**

## Interlock Switches

### Hinge Switches

#### Ensign™ 3



#### Description

The Ensign 3 is a hinge-actuated safety-interlock switch designed to fit at the hinge point of guards. With its rotatable head, the versatile Ensign 3 offers up to four different mounting options.

Operation of the unit is achieved by the hinging action of the guard. The actuation shaft is connected to the existing hinge pin and the degree of operation can be adjusted to suit the application via the adjustable cam in the switch head.



**IMPORTANT:** After adjustment, the cam must be secured in position with the supplied cam locking pin to ensure safety function performance.

The switch includes the necessary safety-related functions, such as forced-guided contacts and a tamper-resistant mechanism, allowing machinery to be safeguarded in compliance with the machinery directive. It is sealed to IP67 and has one conduit entry, M16 or connector style.

#### Features

- Compact size—90.5 x 31 x 30.4 mm (3.56 x 1.22 x 1.2 in) housing
- Ideal for small, lightweight guards
- Degree of operation can be customized with adjustable cam
- Contacts, 2 N.C. & 1 N.O. or 3 N.C. (sealed to IP67)
- Four possible shaft positions, easy to install
- Solid and hollow shafts available

#### Specifications

Safety Ratings	
Standards	EN954-1, ISO13849-1, IEC/EN60204-1, NFPA79, EN1088, ISO14119, IEC/EN60947-5-1, ANSI B11.19, AS4024.1
Safety Classification	Cat. 1 device per EN 954-1 dual channel interlocks suitable for Cat. 3 or 4 systems
Functional Safety Data *	B10d: > 2 x 10 <sup>6</sup> operations at min. load PFH <sub>D</sub> : < 3 x 10 <sup>-7</sup> MTTFd: > 385 years May be suitable for use in performance levels Pl <sub>e</sub> or Pl <sub>d</sub> systems (according to ISO 13849-1:2006) and for use in SIL2 or SIL3 systems (according to IEC 62061) depending on the architecture and application characteristics
Note:	For up-to-date information, visit <a href="http://www.ab.com/Safety/">http://www.ab.com/Safety/</a>
Certifications	CE Marked for all applicable directives, cULus, and TÜV
Outputs	
Safety Contacts *	3 N.C. direct-opening action      2 N.C. direct-opening action
Auxiliary Contacts	—      1 N.O.
Shaft Rotation for Contact Operation	3 N.C. Adjustable 12° max.: 3° min. 2 N.C. 1 N.O. (BBM) Adjustable 14° max.: 5° min. 2 N.C. 1 N.O. (MBB) Adjustable 12° max.: 3° min.
Thermal Current I <sub>th</sub>	10 A
Rated Insulation Voltage	(Ui) 500V
Switching Current @ Voltage, Min.	5 mA @ 5V DC
Utilization Category	
A600/AC-15	(Ue) 600V    500V    240V    120V (Ie) 1.2 A    1.4 A    3 A      6 A
DC-13	(Ue) 24V (Ie) 2 A
Operating Characteristics	
Break Contact Force, Min.	8 cNm (torque on shaft)
Actuation Speed, Max.	160 mm (6.29 in.)/s
Actuation Frequency, Max.	1 cycle/s
Operating Life @ 100 mA load	1,000,000 operations
Environmental	
Enclosure Type Rating	IP67
Operating Temperature [C (F)]	-20...+80° (-4...176°)
Physical Characteristics	
Housing Material	UL Approved glass-filled PBT
Shaft Material	Stainless Steel
Weight [g (lb)]	100 (0.22)
Color	Red

\* Usable for ISO 13849-1:2006 and IEC 62061. Data is based on the B10d value given and:  
- Usage rate of 1op/10 mins., 24 hrs/day, 360 days/year, representing 51840 operations per year  
- Mission time/Proof test interval of 38 years

\* The safety contacts are described as normally closed (N.C.) i.e., with the guard closed, actuator in place (where relevant) and the machine able to be started.

# Interlock Switches Hinge Switches Ensign™ 3

## Product Selection

Contact			Actuator Shaft Dimensions—mm (in)	Shaft Type	Cat. No.			
Safety	Auxiliary	Action			M16 Conduit		Connector*	
					M16	1/2 inch NPT Adaptor	6-Pin Micro (M12)	Connect to ArmorBlock Guard I/O 5-Pin Micro (M12) *
3 N.C.	—	—	80 x Ø10 (3.14 x 0.39)	Solid	440H-E22025	440H-E22050	440H-E22059	—
			60 x Ø8 (2.36 x 0.31)		440H-E22031	440H-E22051	440H-E22060	—
			50 x Ø10 (1.96 x 0.39)	Pre-bored	440H-E22047	440H-E22052	440H-E22061	440H-E2NNPPS
			30 x Ø16 (1.18 x 0.63) bore Ø9.5 (0.37)		440H-E22067	440H-E22068	440H-E22069	440H-E2NNHPS
2 N.C.	1 N.O.	BBM	80 x Ø10 (3.14 x 0.39)	Solid	440H-E22027	440H-E22053	440H-E22037	—
			60 x Ø8 (2.36 x 0.31)		440H-E22033	440H-E22054	440H-E22039	—
			50 x Ø10 (1.96 x 0.39)	Pre-bored	440H-E22048	440H-E22055	440H-E22062	—
			30 x Ø16 (1.18 x 0.63) bore Ø9.5 (0.37)		440H-E22064	440H-E22065	440H-E22066	—
		MBB	80 x Ø10 (3.14 x 0.39)	Solid	440H-E22029	440H-E22056	440H-E22038	—
			60 x Ø8 (2.36 x 0.31)		440H-E22035	440H-E22057	440H-E22040	—
			50 x Ø10 (1.96 x 0.39)	Pre-bored	440H-E22049	440H-E22058	440H-E22063	—
			30 x Ø16 (1.18 x 0.63) bore Ø9.5 (0.37)		440H-E22070	440H-E22071	440H-E22072	—

\* With a 5-pin micro (M12) connector, not all contacts are connected. See page 3-97 for wiring details.  
 \* For connector ratings, see 3-9.

## Recommended Logic Interfaces

Description	Safety Outputs	Auxiliary Outputs	Terminals	Reset Type	Power Supply	Cat. Page No.	Cat. No.
<b>Single-Function Safety Relays</b>							
MSR127RP	3 N.O.	1 N.C.	Removable (Screw)	Monitored Manual	24V AC/DC	5-26	440R-N23135
MSR127TP	3 N.O.	1 N.C.	Removable (Screw)	Auto./Manual	24V AC/DC	5-26	440R-N23132
MSR126T	2 N.O.	None	Fixed	Auto./Manual	24V AC/DC	5-24	440R-N23117
MSR30RT	2 N.O. Solid State	1 N.O. Solid State	Removable	Auto./Manual or Monitored Manual	24V DC	5-16	440R-N23198
<b>Modular Safety Relays</b>							
MSR210P Base 2 N.C. only	2 N.O.	1 N.C. and 2 PNP Solid State	Removable	Auto./Manual or Monitored Manual	24V DC from the base unit	5-82	440R-H23176
MSR220P Input Module	—	—	Removable	—	24V DC	5-86	440R-H23178
MSR310P Base	MSR300 Series Output Modules	3 PNP Solid State	Removable	Auto./Manual Monitored Manual	24V DC	5-102	440R-W23219
MSR320P Input Module	—	2 PNP Solid State	Removable	—	24V DC from the base unit	5-106	440R-W23218

**Note:** For additional Safety Relays connectivity, see page 5-12.  
 For additional Safety I/O and Safety PLC connectivity, see page 5-116.  
 For application and wiring diagrams, see page 10-1.

## Connection Systems

Description	6-Pin Micro	Connections to ArmorBlock Guard I/O 5-Pin Micro (M12)
	3 N.C.-2 N.C. & 1 N.O.	3 N.C.
Cordset	889R-F6ECA-‡	—
Patchcord	889R-F6EGRM-§	889D-F5ACDM-‡
Distribution Box	898R-P68MT-A5	—
Shorting Plug	898R-P61MU-RM	—

‡ Replace symbol with 2 (2 m), 5 (5 m), or 10 (10 m) for standard cable lengths.  
 § Replace symbol with 1 (1 m), 2 (2 m), 3 (3 m), 5 (5 m), or 10 (10 m) for standard cable lengths.  
**Note:** For additional information, see page 7-1.

3-Interlock Switches

# Interlock Switches

## Hinge Switches

### Ensign™ 3

#### Approximate Dimensions

Dimensions are shown in mm (in.). Dimensions are not intended to be used for installation purposes.

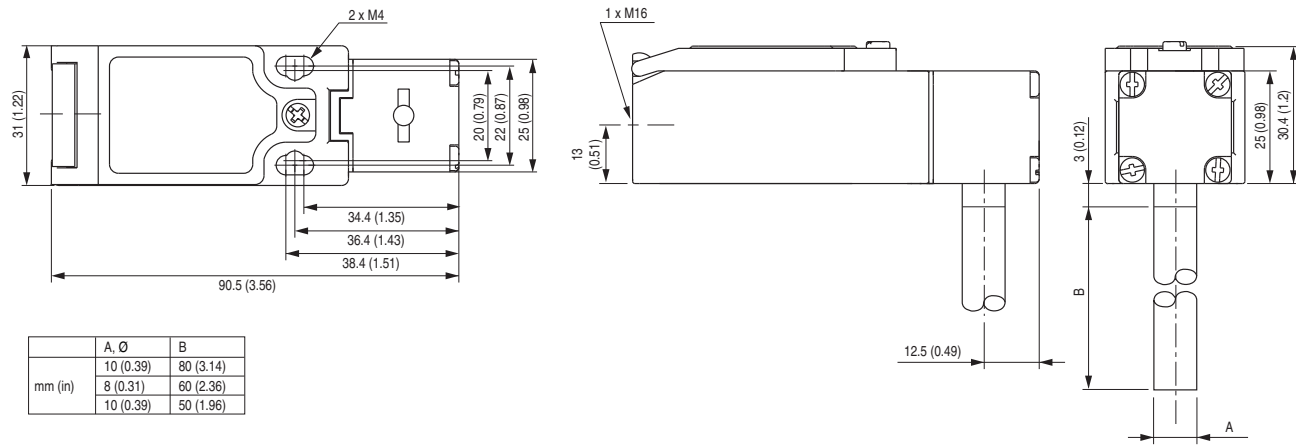

	A, Ø	B
mm (in)	10 (0.39)	80 (3.14)
	8 (0.31)	60 (2.36)
	10 (0.39)	50 (1.96)

#### Hollow Shaft

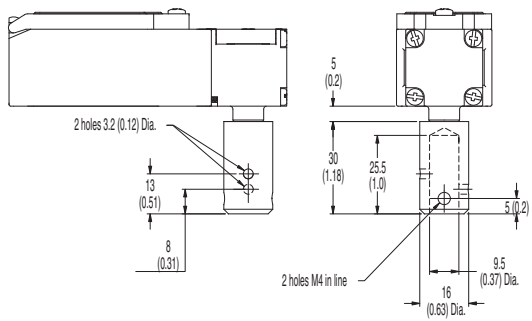

**Note:** 2D, 3D and electrical drawings are available on [www.ab.com](http://www.ab.com).

3-Interlock Switches



# Interlock Switches Hinge Switches Ensign™ 3

## Typical Wiring Diagrams

Description		2 N.C. & 1 N.O.	3 N.C.
Contact Configuration			
Contact Action			
<input type="checkbox"/> Open <input checked="" type="checkbox"/> Closed		BBM	
		MBB	
5-Pin Micro (M12) For ArmorBlock Guard I/O		—	
6-Pin Micro (M12)			
Cordset 889R-F6ECA*	1 Red/White	Safety A	Safety A
	5 Red/Black	Safety A	Safety A
	2 Red	Safety B	Safety B
	6 Red/Blue	Safety B	Safety B
	3 Green	Aux A	Safety C
	4 Red/Yellow	Aux A	Safety C

\* Replace symbol with 2 (2 m), 5 (5 m) or 10 (10 m) for standard cable lengths.

3-Interlock  
Switches

## Interlock Switches

### Hinge Switches

#### Rotacam™



#### Description

The Rotacam is heavy-duty, hinge-actuated safety-interlock switch. It can be used as, or connected to, the existing hinge pin for direct operation of the switch. Machine power is isolated when the guard has been opened just 5°. For applications requiring a larger degree of operation, the internal cam can be adjusted from 5...11°.



**IMPORTANT:** After adjustment, the cam must be secured in position with the supplied cam locking pin to ensure optimal performance.

The Rotacam is available with two N.C. safety contacts and one N.O. auxiliary contact. The switch includes the necessary safety-related functions, such as forced-guided contacts and a tamper-resistant mechanism, allowing machinery to be safeguarded in compliance with the machinery directive.

The die-cast housing is sealed to IP66 and features one M20 conduit entry (1/2 inch NPT and connector style also available). Two different shaft lengths of 30 mm and 85 mm can also be specified.

EX and Pneumatic styles of Rotacam are also available; see page 9-10 for more information.

#### Features

- Can be used as a hinge pin on light- and medium-weight guard doors
- Isolates power within 5° of door movement
- Degree of operation can be customized with adjustable cam
- Robust die-cast case, ideal for heavy-duty applications
- Contacts, 2 N.C. & 1 N.O.

#### Specifications

Safety Ratings	
Standards	EN954-1, ISO13849-1, IEC/EN60204-1, NFPA79, EN1088, ISO14119, IEC/EN60947-5-1, ANSI B11.19, AS4024.1
Safety Classification	Cat. 1 Device per EN954-1 Dual channel interlocks suitable for Cat. 3 or 4 systems
Functional Safety Data *	B10d: > 2 x 10 <sup>6</sup> operations at min. load PFH <sub>D</sub> : < 3 x 10 <sup>-7</sup> MTTF <sub>D</sub> : > 385 years May be suitable for use in performance levels Pl <sub>e</sub> or Pl <sub>d</sub> systems (according to ISO 13849-1:2006) and for use in SIL2 or SIL3 systems (according to IEC 62061) depending on the architecture and application characteristics
Note:	For up-to-date information, visit <a href="http://www.ab.com/Safety/">http://www.ab.com/Safety/</a>
Certifications	CE Marked for all applicable directives, cULus, SUVA, and TÜV
Outputs	
Safety Contacts *	2 N.C. direct opening action
Auxiliary Contacts	1 N.O.
Shaft Rotation for Contact Operation	11° maximum; 5° minimum, (adjustable)
Thermal Current <sub>I<sub>th</sub></sub>	10 A
Rated Insulation Voltage	(U <sub>i</sub> ) 500V
Switching Current @ Voltage, Min.	5 mA @ 5V DC
Utilization Category	
A600/AC-15	(U <sub>e</sub> ) 600V 500V 240V 120V (I <sub>e</sub> ) 1.2 A 1.4 A 3 A 6 A
DC-13	(U <sub>e</sub> ) 24V (I <sub>e</sub> ) 2 A
Operating Characteristics	
Break Contact Force, Min.	12 cNm (torque on shaft)
Actuation Speed, Max.	160 mm (6.29 in.)/s
Actuation Frequency, Max.	1 cycle/s
Operating Life @ 100 mA load	>1,000,000 operations
Environmental	
Enclosure Type Rating	IP66
Operating Temperature [C (F)]	-20...+80° (-4...176°)
Physical Characteristics	
Housing Material	Heavy-duty die-cast alloy
Shaft Material	Stainless Steel
Weight [g (lb)]	420 (0.926)
Color	Red

\* Usable for ISO 13849-1:2006 and IEC 62061. Data is based on the B10D value given and:  
- Usage rate of 1op/10 mins., 24 hrs/day, 360 days/year, representing 51840 operations per year  
- Mission time/Proof test interval of 38 years

\* The safety contacts are described as normally closed (N.C.) i.e., with the guard closed, actuator in place (where relevant) and the machine able to be started.

## Interlock Switches Hinge Switches Rotacam™

### Product Selection

Safety Contacts	Auxiliary Contacts	Contact Action	Shaft Dimensions	Operating Shaft Type	Cat. No.		
					M20 Conduit		Connector§
					M20	1/2 inch NPT Adaptor	8-Pin Micro (M12)
2 N.C.	1 N.O.	BBM	L = 30 (1.18) D = 16 (0.63)	Pre-Bored	440H-R03074	440H-R03078	440H-R03111
			L = 85 (3.35) D = 12.7 (0.5)	Solid	440H-R03079	440H-R03088	440H-R03112

§ For connector ratings, see 3-9.

### Recommended Logic Interfaces

Description	Safety Outputs	Auxiliary Outputs	Terminals	Reset Type	Power Supply	Cat. Page No.	Cat. No.
<b>Single-Function Safety Relays</b>							
MSR127RP	3 N.O.	1 N.C.	Removable (Screw)	Monitored Manual	24V AC/DC	5-26	<b>440R-N23135</b>
MSR127TP	3 N.O.	1 N.C.	Removable (Screw)	Auto./Manual	24V AC/DC	5-26	<b>440R-N23132</b>
MSR126T	2 N.O.	None	Fixed	Auto./Manual	24V AC/DC	5-24	<b>440R-N23117</b>
MSR30RT	2 N.O. Solid State	1 N.O. Solid State	Removable	Auto./Manual or Monitored Manual	24V DC	5-16	440R-N23198
<b>Modular Safety Relays</b>							
MSR210P Base 2 N.C. only	2 N.O.	1 N.C. and 2 PNP Solid State	Removable	Auto./Manual or Monitored Manual	24V DC from the base unit	5-82	440R-H23176
MSR220P Input Module	—	—	Removable	—	24V DC	5-86	440R-H23178
MSR310P Base	MSR300 Series Output Modules	3 PNP Solid State	Removable	Auto./Manual Monitored Manual	24V DC	5-102	440R-W23219
MSR320P Input Module	—	2 PNP Solid State	Removable	—	24V DC from the base unit	5-106	440R-W23218

**Note:** For additional Safety Relays connectivity, see page 5-12.  
For additional Safety I/O and Safety PLC connectivity, see page 5-116.  
For application and wiring diagrams, see page 10-1.

### Connection Systems

Description	8-Pin Micro (M12)
	2 N.C. & 1 N.O.
Cordset	889D-F8AB-*
Patchcord	889D-F8ABDM-*
Distribution Box	—
Shorting Plug	—
T-Port	—

\* Replace symbol with 2 (2 m), 5 (5 m), or 10 (10 m) for standard cable lengths.  
\* Replace symbol with 1 (1 m), 2 (2 m), 3 (3 m), 5 (5 m), or 10 (10 m) for standard cable lengths.  
**Note:** For additional information, see page 7-1.

**3-Interlock  
Switches**

# Interlock Switches

## Hinge Switches

### Rotacam™

#### Approximate Dimensions

Dimensions are shown in mm (in.). Dimensions are not intended to be used for installation purposes.

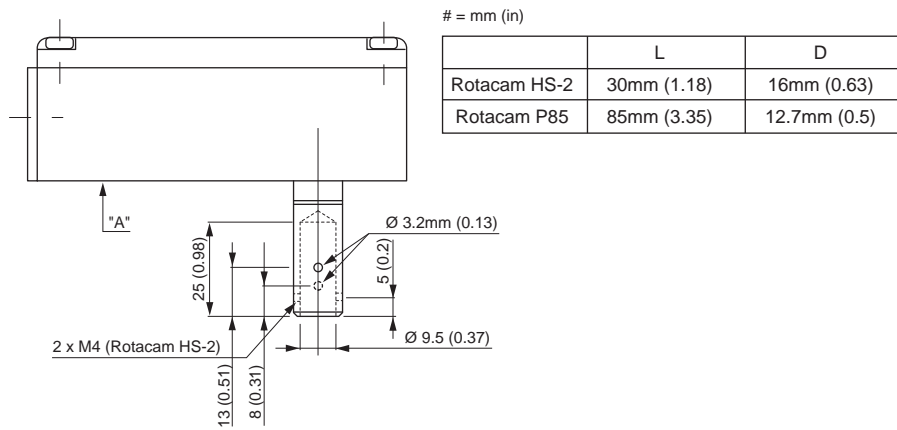
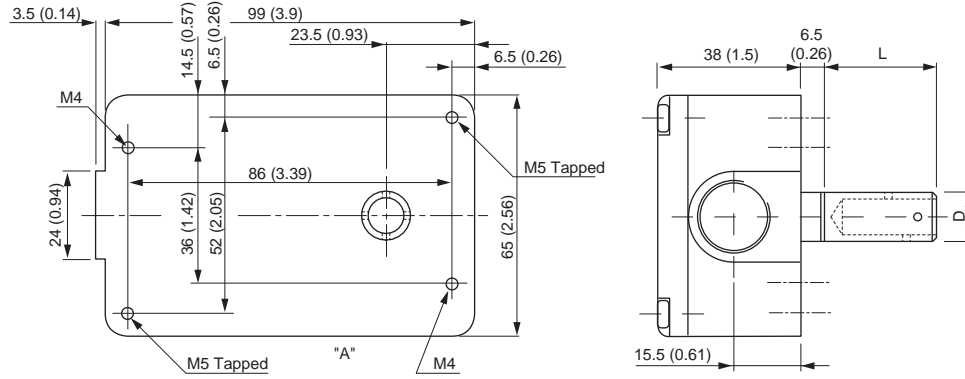

**Note:** Holes only on pre-bored models.  
**Note:** 2D, 3D and electrical drawings are available on [www.ab.com](http://www.ab.com).

3-Interlock Switches

# Interlock Switches Hinge Switches Rotacam™

## Typical Wiring Diagrams

Description		2 N.C. & 1 N.O.
Contact Configuration		
Contact Action	<input type="checkbox"/> Open <input checked="" type="checkbox"/> Closed	
8-Pin Micro (M12) Pin 2 Not Connected		
8-Pin Cordset 889D-F8AB-*	White	Safety A
	Blue	Safety A
	Grey	Safety B
	Pink	Safety B
	Green	Aux A
	Yellow	Aux A
	Red	Ground
	Brown	Not Connected

\* Replace symbol with 2 (2 m), 5 (5 m) or 10 (10 m) for standard cable lengths.

3-Interlock  
Switches

## Safety Switches

# Trapped Key Switches

## Overview

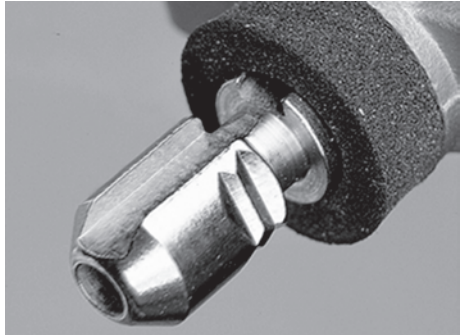

CNC precision cut keys

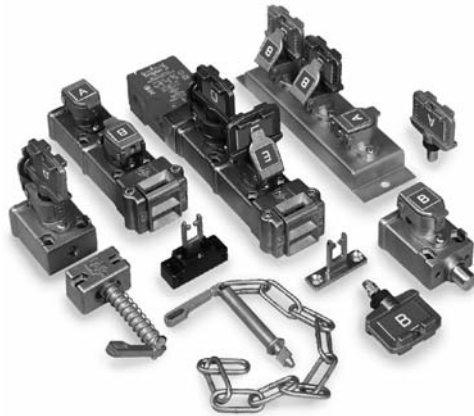

### Interlocking and Control Solutions

#### Trapped Key Interlocks—Why Use Them?

Based upon the premise that no one key can be in two places at once, key interlock systems can be configured to provide that a predetermined sequence of events takes place or that hazards have been reduced before operators can become exposed to them.

It is a mechanical system and is therefore widely used in applications including those where the location of plant, environment or explosive atmospheres make the use of electrical interlock systems unsuitable or expensive to install. In addition, unique coding can be provided, leading to a greater degree of security and tamper-resistance.

#### CE Marking—Tested and Approved

Only Prosafe products carry the prestigious BG mark. A sign of safety, independently tested by the German Berufsgenossenschaftliches Institut für Arbeitssicherheit, "BIA." Additional tests for valve interlocks include Lloyds Certificate for fire test and salt-mist resistance.

#### Over 100,000 Operations

Prosafe products have been subjected to independent, exhaustive testing. With only a small amount of lubricant added infrequently, keys were inserted, rotated and removed at a rate of 12 times per minute. After 100,000 operations (at 10 operations a day this is equivalent to 27 years) the unit was functioning satisfactorily and most importantly would "pass" only the original or equivalent new key. No incorrect keys could operate the lock, underlining the unit's integrity as well as longevity.

#### Why Prosafe?

In order to derive the full benefits from a trapped key interlocking system its components must be totally practical, easily maintainable and readily available. Prosafe's unique key and code barrel gives the ability for even complicated interlocking systems and spare parts to be ordered from our worldwide network of distributors—fast! A first for trapped key interlocks.

#### Five Unique Prosafe Benefits

Compare the following to other trapped key manufacturers:

1. All stainless interlocking and coded parts—including the code barrel and internal components at no extra cost.
2. Weather cap as standard—no extra charge for dust caps and seals.
3. Standard red color-coded key and ID tags—at no extra charge.
4. Custom color/text keys and ID tags—nominal extra charge.
5. A complete range of isolators, key exchange, miniature valve interlocks and gate interlocks—all using the same key principle.

#### The Prosafe Advantage

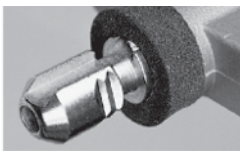

Stainless steel construction.

# Safety Switches Trapped Key Switches Overview

## The Advantage

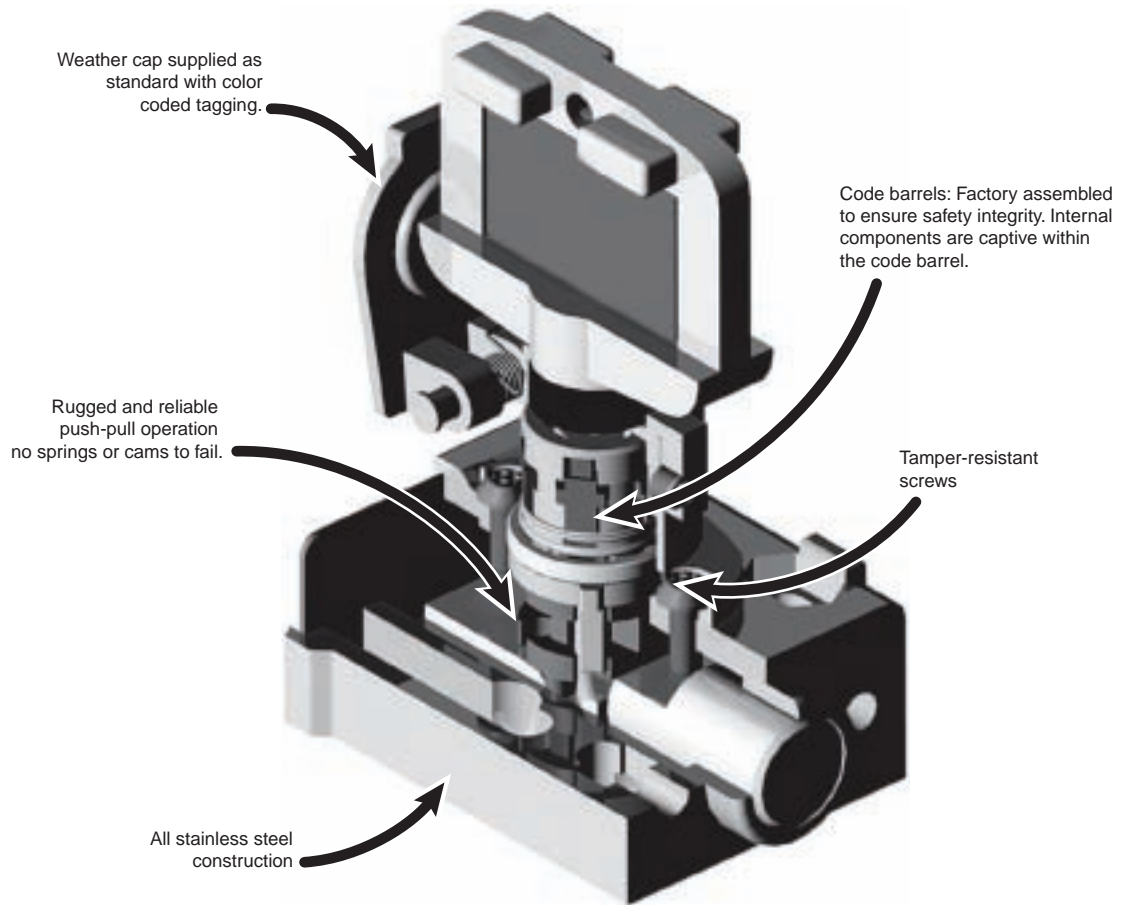

3-Trapped Key Switches

## Prosafe Keys

Compact, solid and sturdy keys supplied with dust seals and coded tagging. Optional colors/text are available.

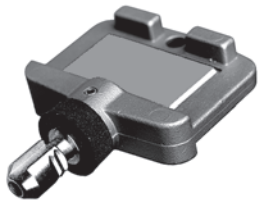

# Safety Switches

## Trapped Key Switches

### Overview

#### Design Suggestions for an Interlocking System

##### Plant and Machinery Interlocking

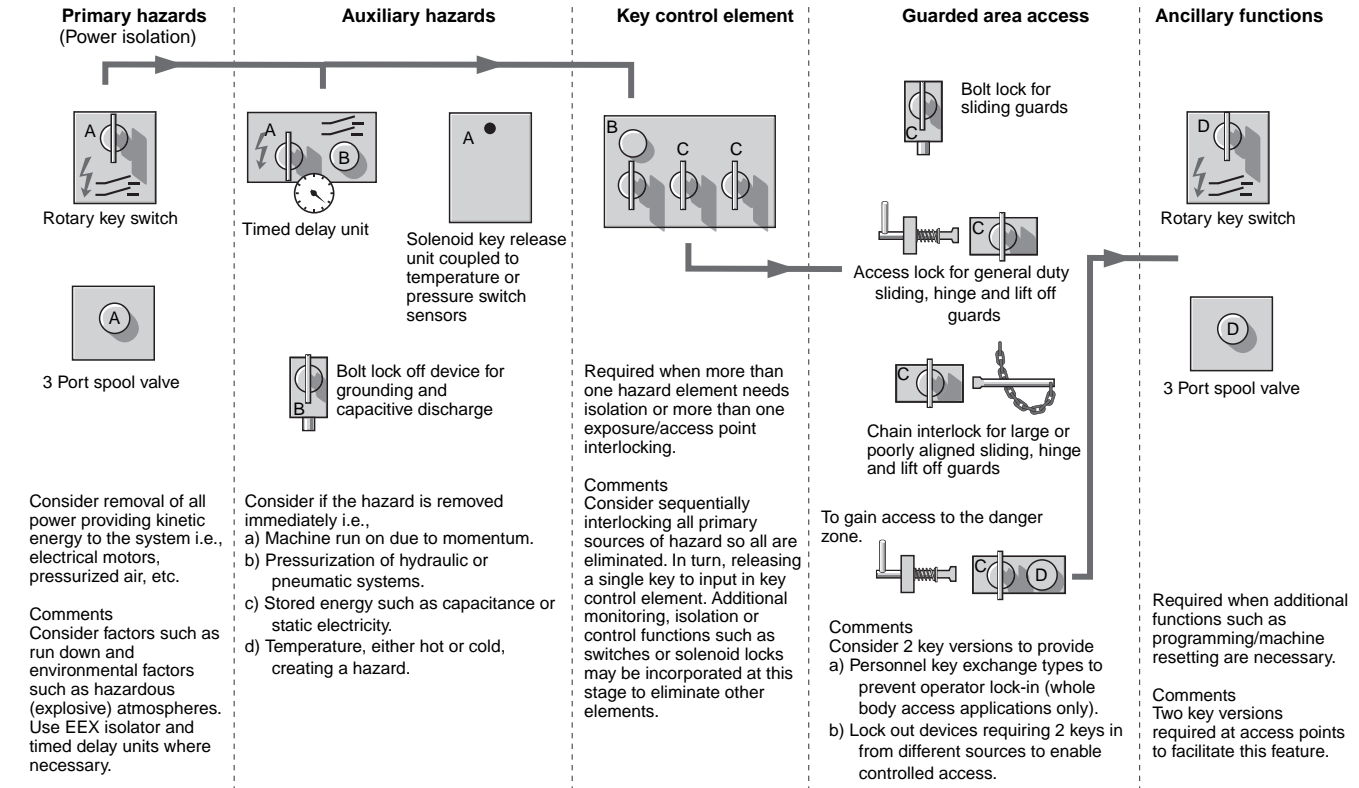

3-Trapped Key Switches

#### The Prosafe Advantage

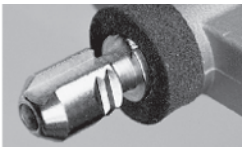

Stainless steel construction.



## Safety Switches Trapped Key Switches Overview

### Illustrated Principles of Trapped Key Interlocking

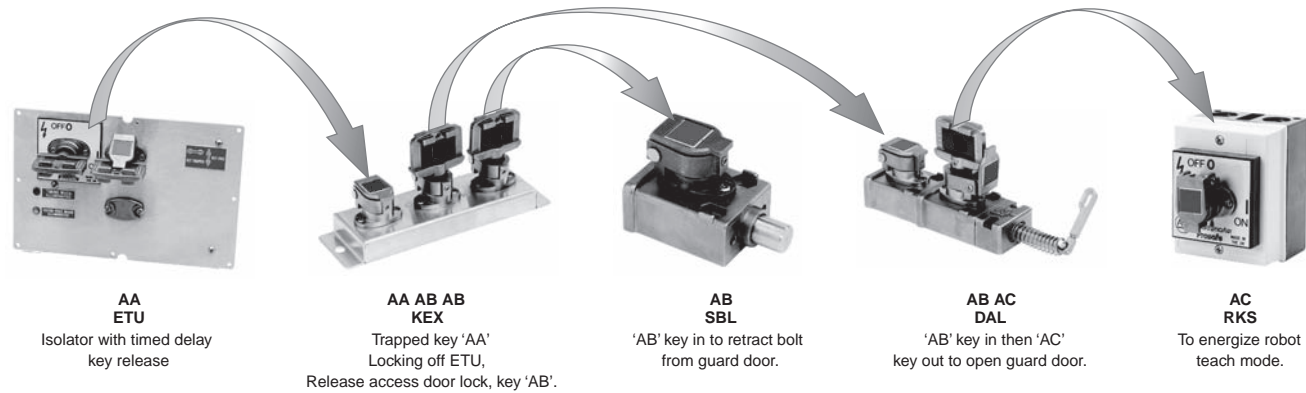

### Sequence of Operation

1. The ETU isolator has two keys. One is a nonremovable key. The other key (a "AA" coded key) can be removed after a timed duration, which is set by a potentiometer inside the ETU isolator. Turn the nonremovable key to turn the hazardous machine motion off and start the timer. When the time expires, the Key Free LED turns ON. Remove the "AA" key.
2. Insert the "AA" key into the Key Exchange Unit (KEX) and turn it 90°.
3. Turn one of the "AB" keys 90° and remove it from the KEX. This traps the "AA" key in the KEX and prevents the restarting of the machine.
4. Insert the "AB" key into the Single-key Bolt Lock (SBL) and turn it 90° to gain partial body access to the machine.
5. Turn the second "AB" key 90° and remove it from the KEX. Removal of this key also traps the "A" key in the KEX and prevents the restarting of the machine.
6. Insert the "AB" key into the Dual-key Access Lock (DAL) and turn it 90°.
7. Turn the "AC" key 90° and remove the "C" key. Rotate the access handle to allow full body entry into the hazard zone.
8. Take the "AC" key into the hazard zone, insert it into the rotary key switch (RKSE) and turn it 90° to send a signal to the machine control system, to allow the machine to operate in a slow or teach mode.
9. Reverse the process to return the machine to full operational mode.

### Bill of Materials

Item	Quantity	Description	Cat. No.
1	1	Single Key Time Delayed with an AA Primary Key	440T-MSTUE11AA
2	1	Key Exchange Unit, AB Primary Key, Two B Secondary Keys Trapped (included)	440T-MKEXE11AAABAB
3	1	Single Bolt Lock, AB Primary Key	440T-MSBLE10AB
4	1	Dual Access Lock, AB Primary Key, C Secondary Key Trapped (included)	440T-MDALE10ABAC
5	1	Rotary Key Switch, AC Primary Code Barrel	440T-MRKSE10AC
6	1	AA Key	440T-AKEYE10AA

**Note:** Primary keys must be ordered separately, when not provided for by a previous sequential trapped key. In the example above, only one primary key must be ordered separately. The remaining primary keys are provided by a previous sequential secondary (trapped) key.

3-Trapped Key Switches

# Safety Switches

## Trapped Key Switches

### Overview

#### Code Selection

Ordering Prosafe trapped key products requires codes to be included in the cat. no.

- The codes are added to the end of the cat. no.
- Each code must be two characters in length.
- The first code(s) is the primary code and the last code(s), if necessary, are the secondary code(s).
- Primary codes do not include the key. The key must be ordered separately or must come from a previous operation.
- Secondary codes come complete with a key, as the key is trapped in the code barrel.
- Use the tables on page 3-107 to select and track codes.

#### Ordering Example 1

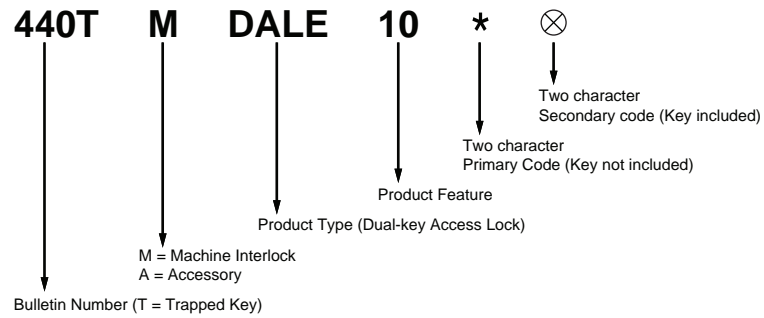

Order Cat. No. 440TMDALE100AAAB to get a Dual key Access Lock with an "AA" primary code and a "AB" secondary code, with a "AB" key included.

#### Ordering Example 2

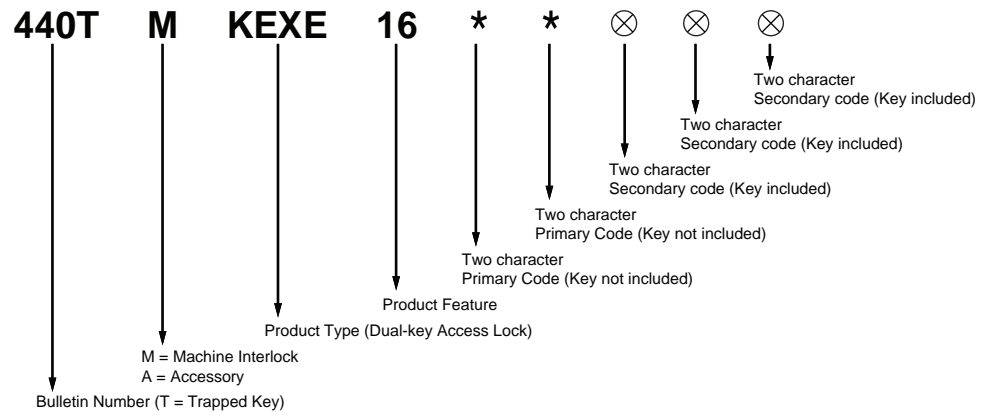

Order Cat. No. 440TMKEXE16AAABACACAC to get a key exchange unit with "AA" and "AB" primary codes and three "AC" secondary codes. The "AA" and "AB" keys are not included. The three "AC" keys, which are trapped in the secondary code barrels, are included.

3-Trapped Key Switches

#### The Prosafe Advantage



Stainless steel construction.

## Safety Switches Trapped Key Switches Overview

### Key Coding

Below is an example reference guide that is useful in selecting and tracking codes. Start down the Aa column as the lower codes (typically Aa to Za) are stocked. The chart continues on to Zz. Note that there are only 24 letters used—O & Q are not used.

Codes are ordered with upper case letters. Labels with two letter codes will show the first letter in the upper case and the second letter in lower case.

	Code	Application & Date	Code	Application & Date	Code	Appli & Da
Start Down ↓	Aa	<i>granulator machine #472 24/8/01</i>	Ab	<i>ime 67</i>	Ac	
	Ba		Bb		Bc	
	Ca		Cb		Cc	
	Da		Db		Dc	

Code	Application & Date	Code	Application & Date	Code	Application & Date	Code	Application & Date	Code	Application & Date	Code	Application & Date
Aa		Ab		Ac		Ad		Ae		Af	
Ba		Bb		Bc		Bd		Be		Bf	
Ca		Cb		Cc		Cd		Ce		Cf	
Da		Db		Dc		Dd		De		Df	
Ea		Eb		Ec		Ed		Ee		Ef	
Fa		Fb		Fc		Fd		Fe		Ff	
Ga		Gb		Gc		Gd		Ge		Gf	
Ha		Hb		Hc		Hd		He		Hf	
Ia		Ib		Ic		Id		Ie		If	
Ja		Jb		Jc		Jd		Je		Jf	
Ka		Kb		Kc		Kd		Ke		Kf	
La		Lb		Lc		Ld		Le		Lf	
Ma		Mb		Mc		Md		Me		Mf	
Na		Nb		Nc		Nd		Ne		Nf	
Pa		Pb		Pc		Pd		Pe		Pf	
Ra		Rb		Rc		Rd		Re		Rf	
Sa		Sb		Sc		Sd		Se		Sf	
Ta		Tb		Tc		Td		Te		Tf	
Ua		Ub		Uc		Ud		Ue		Uf	
Va		Vb		Vc		Vd		Ve		Vf	
Wa		Wb		Wc		Wd		We		Wf	
Xa		Xb		Xc		Xd		Xe		Xf	
Ya		Yb		Yc		Yd		Ye		Yf	
Za		Zb		Zc		Zd		Ze		Zf	

3-Trapped Key Switches

## Safety Switches Rotary Switches



### Description

The rotary switches are used for electrical isolation of machinery to improve safe access and also as teach boxes in robot cells. Once the power has been turned off, the key can then be withdrawn and used in the next sequence of operation such as unlocking an access hatch or allowing valves to be operated.

The rotary switch can either be mounted in a panel or purchased in an enclosure. The rotary switch is available with 4 poles, either 4 N.O. or 2 N.C. and 2 N.O. The 100 A 4 N.O. switch has 3 contacts rated at 100 A and 1 contact rated at 20 A.

### Features

- 316L stainless steel keys
- Direct drive operation—positively opens contacts
- Stainless steel dust cap included
- Up to 400 A isolation
- 4 N.O., 2 N.O. and 2 N.C., 3 N.O./1 N.C., 3 N.O., or 3 N.C. and neutral contacts
- Replaceable code barrel assembly

### Specifications

#### Safety Ratings

Standards	EN1088, IEC/EN60204-1, IEC/EN60947-5-1, ISO12100-1&2, ISO14119, GS-ET-19, AS4024.1, UL508, CSA 22.2
Category	Cat. 1 per EN 954-1 (ISO 13849-1) Suitable for Cat. 2, 3, and 4 systems
Certifications	CE Marked for all applicable directives, BG, cULus on contact block; C-Tick not required

#### Operating Characteristics

Conduit Entry	4 x M20 (RKS only)
Mechanical Life	100,000 operations
Finger Protection	DIN 57106/VDE 0106 T.100

#### Environmental Characteristics

Operating Temperature [C (F)]	-10...+40 ° (14...104 °)
Relative Humidity	95%

#### Physical Characteristics

Shear Force to Key	15.1 k•N (3398 lbs), max.
Torque to Key	14 N•m (124 lb•in), max.

### Specifications (continued)

Weight [g (lbs)]	RPSE	10, 11, 12, 13, 20:	500 (1.1)	14, 16:	1000 (2.2)
	RKSE	10, 11, 12, 13:	850 (1.9)	14, 16:	1250 (2.8)
Electrical Life	100,000 operations				
Climatic Test	Constant to DIN IEC 68 Part 2-3 Variable to DIN IEC 68 Part 2-30				
Ambient Temperature, Operation	Encased -25...40 °C (10...104 °F)				
(Ui) Rated Insulation Voltage	690V				
(Uimp) Rated Impulse withstand Voltage	6 kV				
S3 Intermittent Rating Duty Factor (VDE 0530, Part 1)	60/40/25% = 1, 3/1, 6/2 xlu				
Last two digits of Cat. No. (See Product Selection table)	10 11 16	12	13	14	
Rated Uninterrupted Current (Iu)	IEC/EN/VDE	20A	32A	63A	100A
	UL/CSA	16A	30A	60A	100A
Rated Operational Voltage (Ue)	IEC/EN/VDE	690V	690V	690V	1000V
	UL/CSA	600V	600V	600V	600V
	Main Switch Isolation Voltage, Max.	750V	750V	750V	1000V
Rated Operational Current (Ie)	AC-21A IEC/EN/VDE	20A	32A	63A	100A
	AC-1 SEV	20A	32A	63A	100A
Rated Operational Power at 50/60 Hz (AC-23A IEC/EN/VDE)	3-phase 220...240V	4 kW	5.5 kW	15 kW	22 kW
	3-pole 380...440V	7.5 kW	11 kW	22 kW	37 kW
	500...690V	7.5 kW	11 kW	22 kW	37 kW
Rated Operational Power at 50/60 Hz (AC-3A IEC/EN/VDE)	3-phase 220...240V	3 kW	4 kW	11 kW	22 kW
	3-pole 380...440V	5.5 kW	7.5 kW	18.5 kW	30 kW
	500...690V	5.5 kW	7.5 kW	18.5 kW	30 kW
DOL Rating (UL/CSA)	3-phase 140V	1 HP	2 HP	5 HP	10 HP
	3-pole 240V	2 HP	5 HP	15 HP	25 HP
	480V	5 HP	10 HP	30 HP	30 HP
Rated Breaking Capacity	600V	5 HP	10 HP	40 HP	30 HP
	AC-23/AC-3 220...240V	250A	330A	500A	600A
	Motor Switch 380...440V	250A	330A	500A	600A
Fuse Rating (GI)	500...690V	150A	220A	270A	300A
		25 A, max.	35 A, max.	63/50 A, max.	100 A, max.
Rated Fuse Short Circuit Current		15 kA	15 kA	15/20 kA	25 kA
Terminal Cross Section		1...10 mm <sup>2</sup> single/multiple wire		4...16	2.5...3.5
Conductor Size, mm <sup>2</sup> min...max		0.75 ...6 (stranded) with sleeve		2.5...10	1.5...2.5
		8 AWG		6 AWG	2 AWG

3-Trapped Key Switches

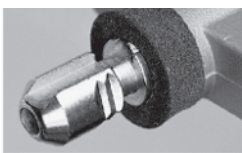

### The Prosafe Advantage





Stainless steel construction.

## Safety Switches Rotary Switches

### Product Selection

Type	Contact Type	Current Accuracy	Cat. No.
 Enclosure Mounted (RKS only)	4 N.O.	20 A	440T-MRKSE10*
	2 N.O. & 2 N.C.	20 A	440T-MRKSE11*
	4 N.O.	32 A	440T-MRKSE12*
	4 N.O.	63 A	440T-MRKSE13*
	3 N.O. & 1 N.O.	3 N.O. 100 A and 1 N.O. 20 A	440T-MRKSE14*
Mild Steel Enclosure Mounted (RKS only)	8 N.O.	20 A	440T-MRKSE16*
	3 N.O. + Neutral	200 A	440T-MRKSE21*
 Panel Mounted	3 N.O.	400 A	440T-MRKSE22*
	4 N.O.	20 A	440T-MRPSE10*
	2 N.O. & 2 N.C.	20 A	440T-MRPSE11*
	4 N.O.	32 A	440T-MRPSE12*
	4 N.O.	63 A	440T-MRPSE13*
	3 N.O. & 1 N.O.	3 N.O. 100 A and 1 N.O. 20 A	440T-MRPSE14*
	8 N.O.	20 A	440T-MRPSE16*
	3 N.O. & 3 N.C.	20 A	440T-MRPSE18*
	4 N.O.	40 A	440T-MRPSE20*

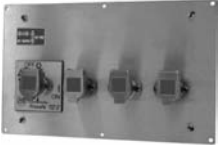
\* Substitute the desired primary code for this symbol (key not included). See page 3-107.

Type	Number of Keys	Contact Type	Current Accuracy	Cat. No.	
<b>Isolator on First Key Out</b>					
	Dual key isolator	2 keys out	4 N.O.	20 A	440T-MMRSE10**
			2 N.O. & 2 N.C.	20 A	440T-MMRSE11**
			4 N.O.	32 A	440T-MMRSE12**
			4 N.O.	63 A	440T-MMRSE13**
	Triple key isolator	3 keys out	4 N.O.	20 A	440T-MMRSE20***
			2 N.O. & 2 N.C.	20 A	440T-MMRSE21***
			4 N.O.	32 A	440T-MMRSE22***
			4 N.O.	63 A	440T-MMRSE23***
	Quad key isolator	4 keys out	4 N.O.	20 A	440T-MMRSE30****
			2 N.O. & 2 N.C.	20 A	440T-MMRSE31****
			4 N.O.	32 A	440T-MMRSE32****
			4 N.O.	63 A	440T-MMRSE33****
	Dual key exchange isolator	1 key in/ 1 key out	4 N.O.	20 A	440T-MMRXE10*⊗
			2 N.O. & 2 N.C.	20 A	440T-MMRXE11*⊗
			4 N.O.	32 A	440T-MMRXE12*⊗
			4 N.O.	63 A	440T-MMRXE13*⊗
	Triple key exchange isolator	1 key in/ 2 key out	4 N.O.	20 A	440T-MMRXE20*⊗⊗
			2 N.O. & 2 N.C.	20 A	440T-MMRXE21*⊗⊗
			4 N.O.	32 A	440T-MMRXE22*⊗⊗
			4 N.O.	63 A	440T-MMRXE23*⊗⊗
	Quad key exchange isolator	1 key in/ 3 key out	4 N.O.	20 A	440T-MMRXE30*⊗⊗⊗
			2 N.O. & 2 N.C.	20 A	440T-MMRXE31*⊗⊗⊗
			4 N.O.	32 A	440T-MMRXE32*⊗⊗⊗
			4 N.O.	63 A	440T-MMRXE33*⊗⊗⊗

\* Substitute the desired primary code for this symbol (key not included). See page 3-107.

⊗ Substitute the desired secondary code for this symbol (key included). See page 3-107.

**3-Trapped Key  
Switches**

## Safety Switches Rotary Switches

### Accessories

Description	Additional Information	Cat. No.
Stainless steel key		440T-AKEYE10*
Stainless steel replacement code barrel for products other than 100 A RPS/RKS units with dust cap	3-140	440T-ASCBE14*
Stainless steel replacement code barrel for 100 A unit rotary switch		440T-ASCBE11*
Stainless steel weatherproof replacement dust cap		440T-ASFC10*
Cable grip, M20 conduit, accommodates cable diameter 7...10.5 mm (0.27...0.41 in.)	3-53	440A-A09028
Adaptor, conduit, M20 to 1/2 inch NPT, plastic		440A-A09042
Supplemental Contact Block, 20 A, 1 N.O. Late Make, Early Break 1 N.C. Auxiliary	For use with RPSE12, RPSE20 (maximum 1 per switch)	440T-AACA10
Supplemental Contact Block, 20 A, 2 N.O. Late Make, Early Break	For use with RPSE12, RPSE20 (maximum 1 per switch)	440T-AACA11
Supplemental Contact Block, 20 A, 1 N.O., 1 N.C.	For use with RPSE13 & 14	440T-AACA20
Supplemental Contact Block, 20 A, 2 N.O.	For use with RPSE13 & 14	440T-AACA21
ABS plastic enclosure	For use with dual key, and dual key exchange, isolators	440T-AIPB10
Stainless steel enclosure (240x180x150 mm)	For use with >20 A RPSE units (not including RPSE21 or 22)	440T-AIPB25
Stainless steel enclosure (150x150x80 mm)	For use with RPSE10 & 11	440T-AIPB26
ABS plastic enclosure	For use with triple/quad key, and triple/quad key exchange, isolators	440T-AIPB50
Stainless steel enclosure	For use with triple/quad key, and triple/quad key exchange, isolators	440T-AIPB55

\* Substitute the desired primary code for this symbol (key not included). See page 3-107.

### Approximate Dimensions [mm (in.)]

Dimensions are not intended to be used for installation purposes.

#### MRKSE10 and MRKSE11

3-Trapped Key  
Switches

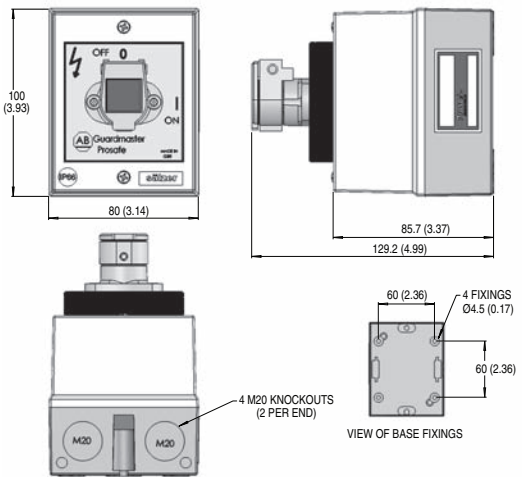

#### MRKSE12 and MRKSE13

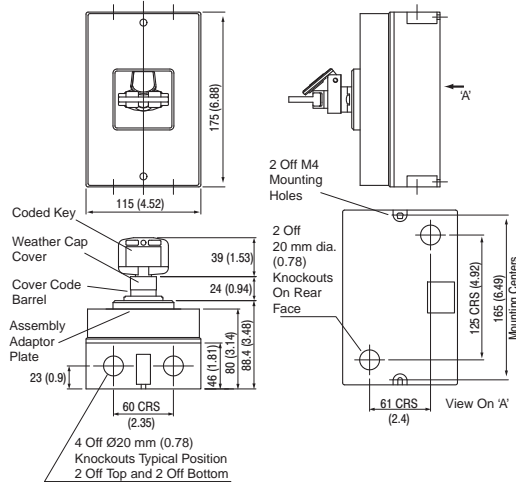

#### MMRSE10

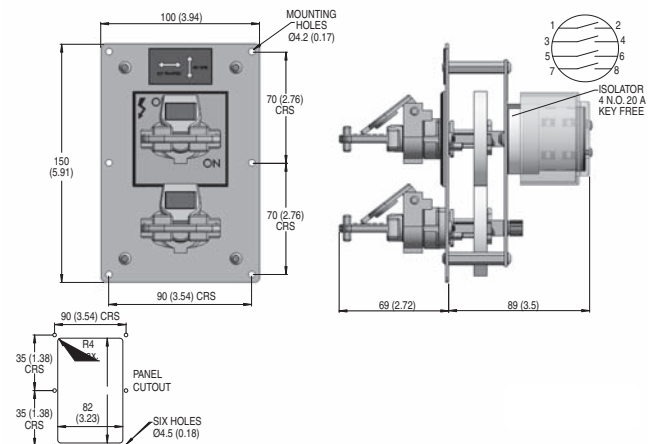

#### MMRSE20

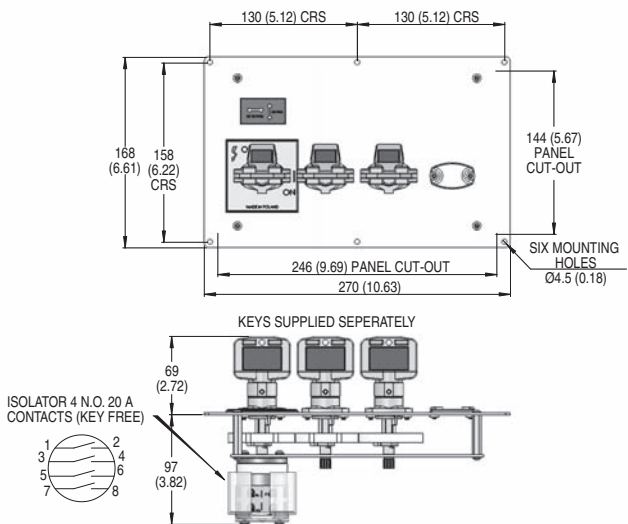

## Safety Switches Rotary Switches

### Approximate Dimensions [mm (in.)] (continued)

Dimensions are not intended to be used for installation purposes.

#### MRKSE14

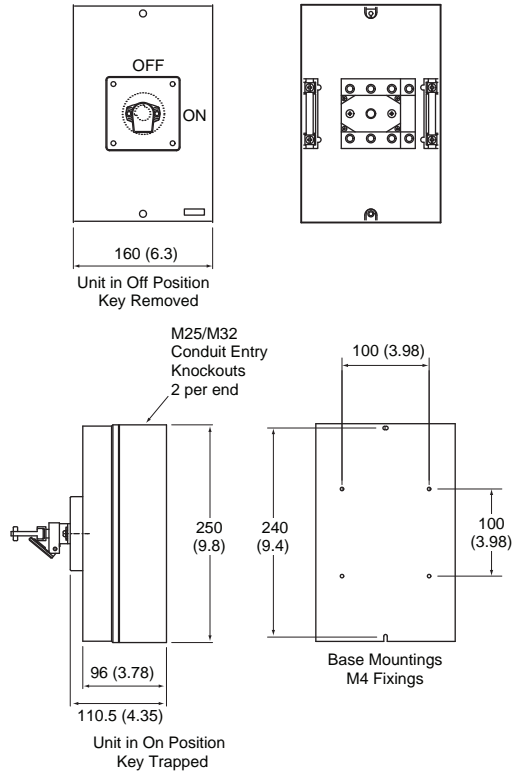

#### MRKSE16

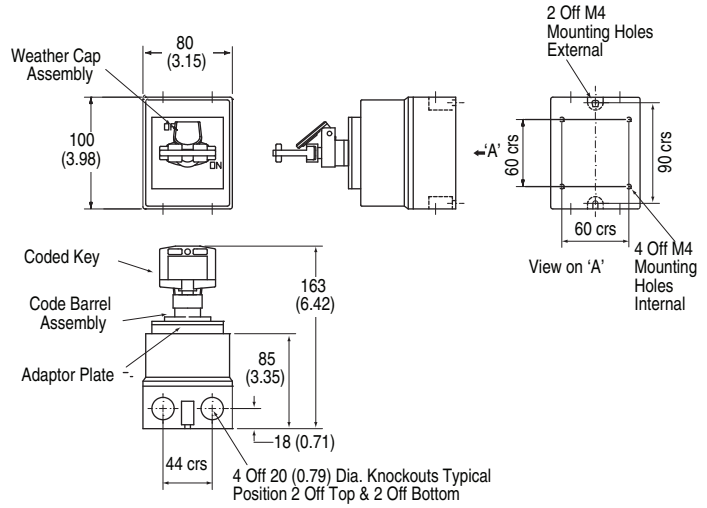

#### MRPSE10 and 11

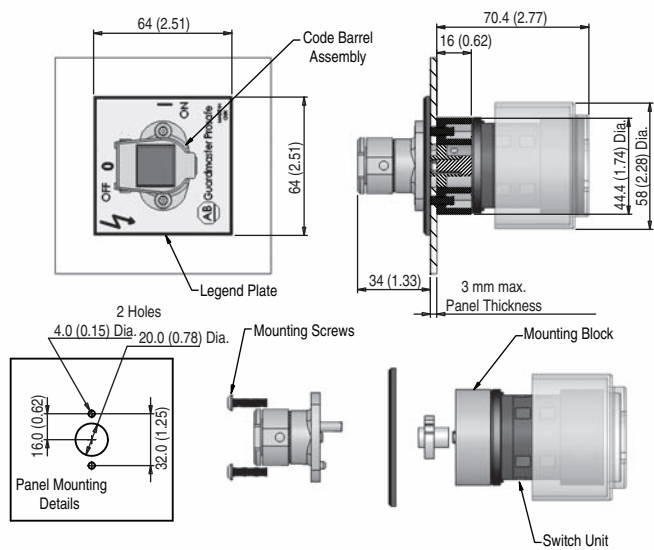

#### MRPSE 12, 13, 14 and 20

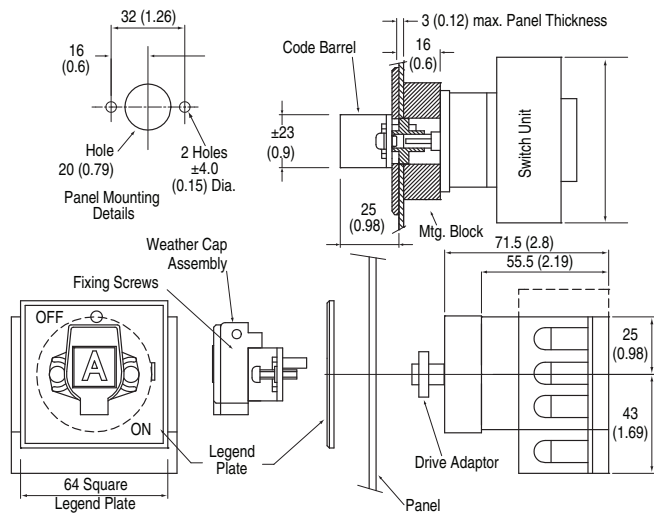

3-Trapped Key  
Switches

## Safety Switches Rotary Switches

### Approximate Dimensions [mm (in.)] (continued) MMRXE10 and MMRXE11

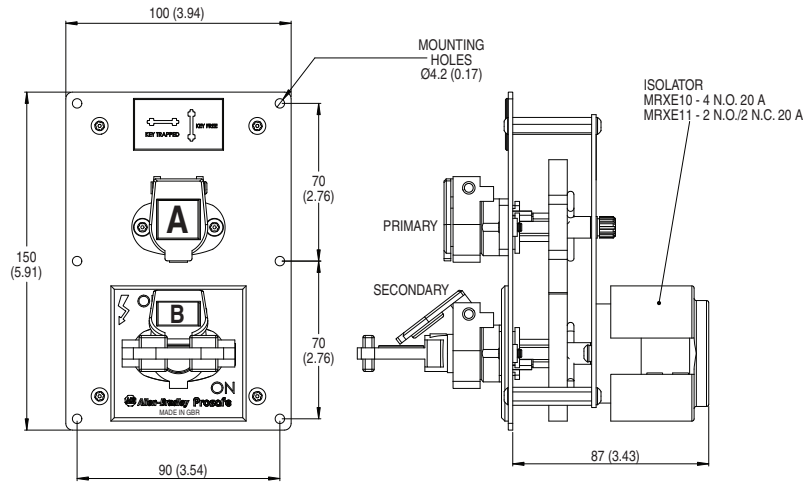

### MMRXE30

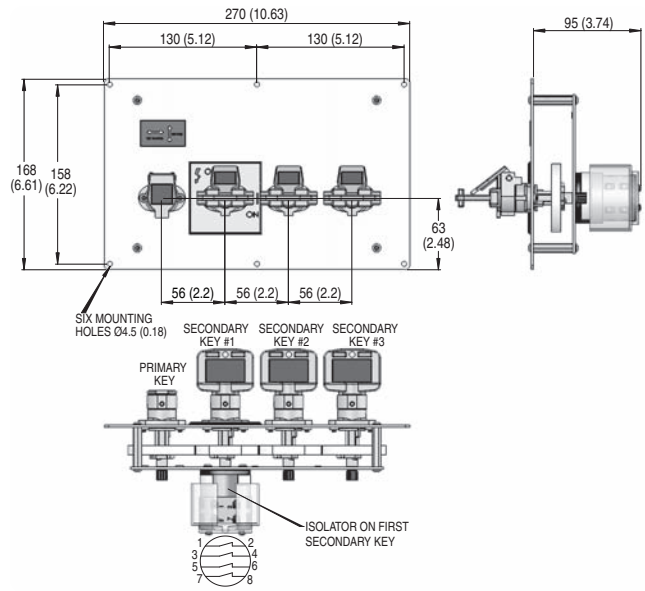

### MRKSE22

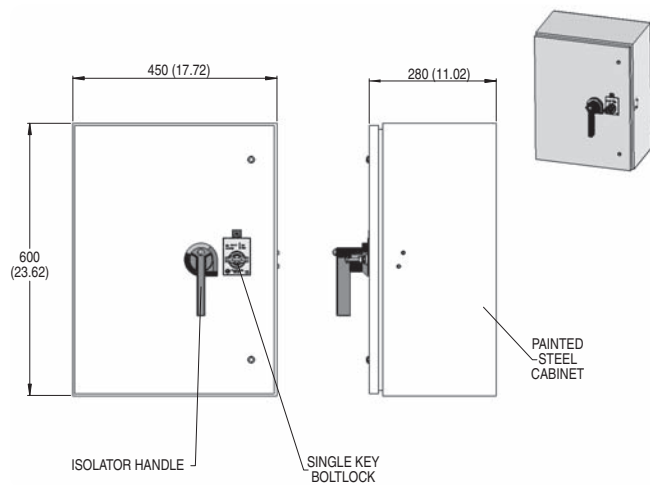

3-Trapped Key  
Switches



## Safety Switches Rotary Switches

### Approximate Dimensions [mm (in.)] (continued)

#### MRPSE16

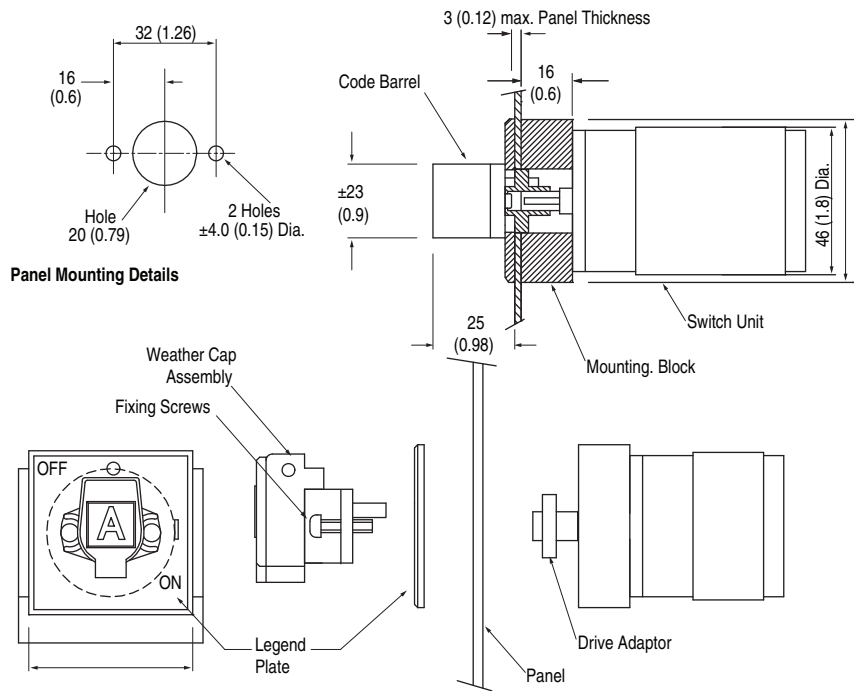

### Typical Wiring

#### Diagrams Shown with Key Free

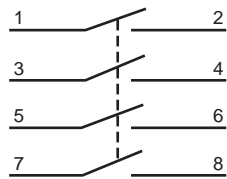

MRKSE10 and MRPSE10  
MRKSE12 and MRPSE12  
MRKSE13 and MRPSE13  
----- and MRPSE20  
MMRSE10 and MMRXE10  
MMRSE12 and MMRXE12  
MMRSE13 and MMRXE13  
MMRSE20 and MMRXE20  
MMRSE22 and MMRXE22  
MMRSE23 and MMRXE23  
MMRSE30 and MMRXE30  
MMRSE32 and MMRXE32  
MMRSE33 and MMRXE33

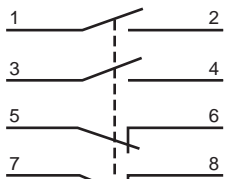

MRKSE11 and MRPSE11  
MMRSE11 and MMRXE11  
MMRSE21 and MMRXE21  
MMRSE31 and MMRXE31

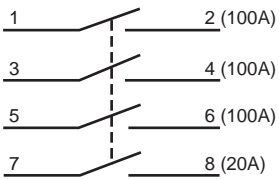

MRKSE14 and MRPSE14

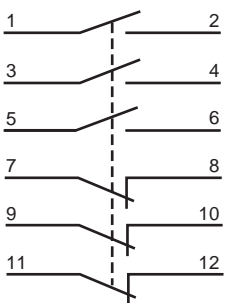

MRKSE18 and MRPSE18

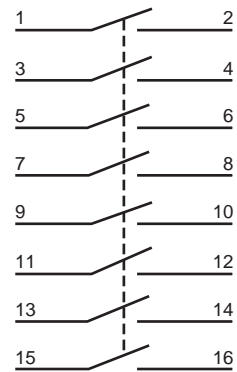

MRKSE16 and MRPSE16

3-Trapped Key  
Switches

## Safety Switches

### Solenoid Release Units



#### Description

The solenoid release unit is used for electrical isolation of machinery to improve safe access. It consists of a rotary power switch and a solenoid. The trapped key can be removed once an external signal is given to its internal solenoid locking mechanism. An indicator light on the solenoid release unit indicates when the trapped key can be removed; that is, when power is applied to the solenoid. The solenoid signal only needs to be present when key removal is necessary. The solenoid is rated for 100% duty cycle. Power to the solenoid can be removed after the trapped key is removed.

Rotating the trapped key causes the isolating power switch to change state; the normally open contacts open and the normally closed contacts (if applicable) will close.

The trapped key can then be used in the next sequence of the operation.

#### Features

- Direct drive operation—positively opens contacts
- Integral solenoid monitoring
- Key trapped until release signal is applied
- LED or NEON "key free" indication
- 316L stainless steel construction
- 24V DC, 110V AC or 230V AC solenoid options
- Weatherproof stainless steel dust cap as standard
- UL and CSA Approval on switches
- Single or multiple key units available (contact factory)
- Replaceable code barrel assembly

#### Specifications

##### Safety Ratings

Standards	EN1954-1, IEC/EN60204-1, EN1088, IEC/EN60947-5-1, ISO13849-1, ISO12100-1&2, ISO14119, GS-ET-19, AS4024.1
Certifications	CE Marked for all applicable directives and BG

##### Operating Characteristics

Solenoid Voltage	24V DC, 110V AC, 230V AC
Solenoid Power	DC Types: 6.5 W continuous AC Types: 6V A continuous
Electrical Life	100,000 operations
Mechanical Life	100,000 operations

##### Utilization Category

Electrical Characteristics	See rotary power switches.
----------------------------	----------------------------

##### Environmental & Physical Characteristics

Shear Force to Key	15.1 k•N (3398 lbs), max.
Torque to Key	14 N•m (124 lb•in), max.
Material	Trapped Key Components: 316L stainless steel Steel Face Plate: 316L stainless steel Optional Box: ABS plastic
Operating Temperature [C (F)]	0...40 ° (32...104 °)
Relative Humidity	95%

### 3-Trapped Key Switches

#### The Prosafe Advantage



Stainless steel construction.

## Safety Switches Solenoid Release Units

### Product Selection

Type	Solenoid Voltage	Contacts	Current, Nom	Cat. No.	
Single key out	24V DC	2 N.O. & 2 N.C.	20 A	440T-MSRUE11*	
		4 N.O.		440T-MSRUE10*	
		3 N.O. & 3 N.C.	32 A	440T-MSRUE12*	
	110V AC	2 N.O. & 2 N.C.	4 N.O.	20 A	440T-MSRUE13*
					440T-MSRUE22*
		3 N.O. & 3 N.C.	4 N.O.	32 A	440T-MSRUE20*
					440T-MSRUE23*
	230V AC	2 N.O. & 2 N.C.	4 N.O.	20 A	440T-MSRUE14*
					440T-MSRUE24*
		3 N.O. & 3 N.C.	63 A	440T-MSRUE33*	
	110V DC	2 N.O. & 2 N.C.	4 N.O.	20 A	440T-MSRUE30*
					440T-MSRUE34*
440T-MSRUE35*					
3 N.O. & 3 N.C.		4 N.O.	63 A	440T-MSRUE44*	
				440T-MSRUE40*	
				440T-MSRUE46*	
Dual key out	24V DC	4 N.O.	20 A	440T-MS2097D**	
		2 N.O. & 2 N.C.		440T-MS2097A**	
		4 N.O.	32 A	440T-MS2097G**	
		4 N.O.	63 A	440T-MS2097J**	
Triple key out	24V DC	4 N.O.	20 A	440T-MS3417D***	
		2 N.O. & 2 N.C.		440T-MS3417A***	
		4 N.O.	32 A	440T-MS3417G***	
		4 N.O.	63 A	440T-MS3417J***	
Quad key out	24V DC	4 N.O.	20 A	440T-MS3418D****	
		2 N.O. & 2 N.C.		440T-MS3418A****	
		4 N.O.	32 A	440T-MS3418G****	
		4 N.O.	63 A	440T-MS3418J****	

\* Substitute the desired primary code for this symbol (key not included). See 3-107.

### Accessories

Description	Additional Information	Cat. No.
Stainless steel key	3-140	440T-AKEYE10*
Stainless steel replacement code barrel with dust cap		440T-ASCBE14*
Stainless steel weatherproof replacement dust cap		440T-ASFC10*
Optional plastic enclosure	For use with single key out 20 A units	440T-AIPB10
	For use with single key out 32 A units	440T-AIPB22
Optional ABS plastic enclosure	For use with triple/quad key out units	440T-AIPB50
Optional stainless steel enclosure	For use with triple/quad key out units	440T-AIPB55

\* Substitute the desired primary code for this symbol (key not included). See 3-107.

3-Trapped Key  
Switches

## Safety Switches Solenoid Release Units

### Approximate Dimensions [mm (in.)]

Dimensions are not intended to be used for installation purposes.

#### MSRUE13

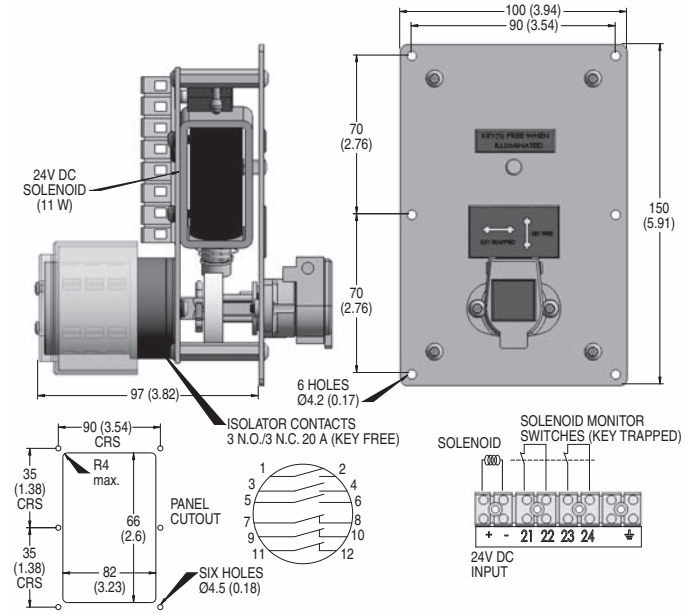

#### MS2097

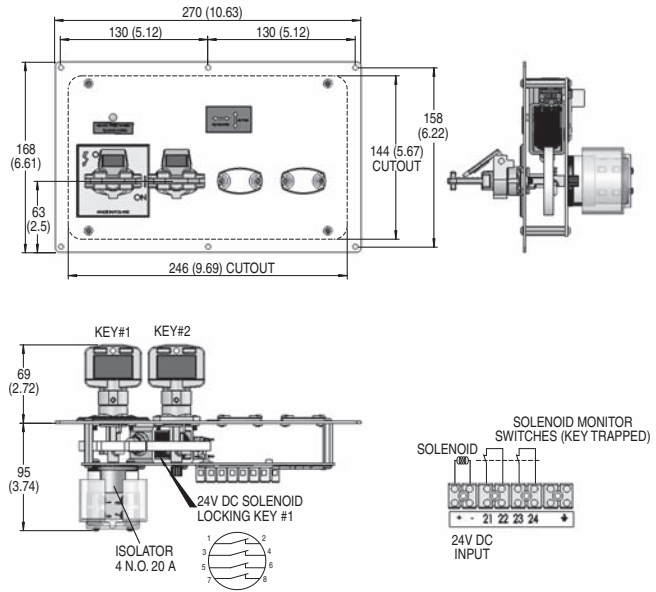

#### MSRUE35

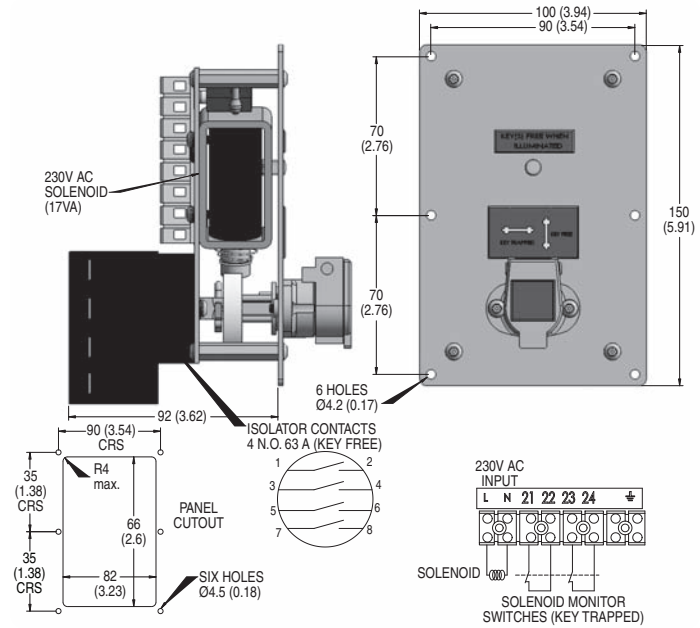

#### MS3417

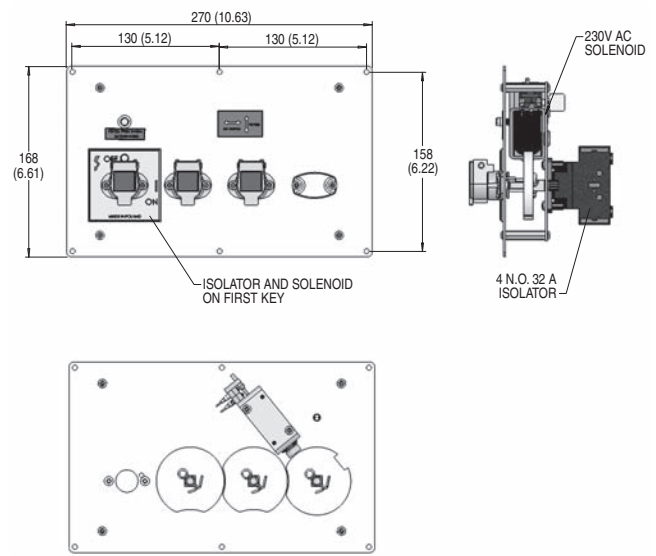

3-Trapped Key  
Switches

### Typical Wiring

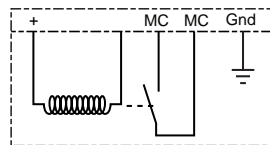

## Safety Switches

### Electronic Timed-Delay Units



#### Description

The Electronic Timed-delay Unit (ETU) is used in applications that require an elapsed time to occur before allowing access to a hazardous area. The ETU uses an CU1 control unit timer to execute the timing sequence. Turning a nonremovable key initiates the timer. When the CU1 times out, its output energizes an internal solenoid, which then allows the removal of either one or two trapped keys.

The Single-key Timed delay Unit (STU) has one trapped key. After the CU1 preset time has expired, the single trapped key can be removed and used to continue the next sequence in allowing access to the hazard. The single key must be returned to the STU and trapped to allow the nonremovable key to re-initiate the hazard.

The Dual-key Timed delay Unit (DTU) has two trapped keys. After the CU1 preset time has expired, both keys can be removed and used to continue the next sequences in allowing access to the hazard. Both keys must be returned to the DTU and trapped to allow the nonremovable key re-initiate the hazard.

#### Features

- Timed-delay output up to 40 minutes
- Single key or dual key
- 316L stainless steel keys
- Category 1 Stop
- Replaceable code barrel assembly

#### Specifications

##### Safety Ratings

Standards	IEC/EN60204-1, EN1088, IEC/EN60947-5-1, ISO13849-1, ISO12100-1&2, ISO14119, GS-ET-19, AS4024.1
Category	Cat. 1 per EN 954-1 (ISO 13849-1)
Certifications	CE Marked for all applicable directives and BG

##### Operating Characteristics

Electrical Life	100,000 operations
Mechanical Life	100,000 operations
Solenoid Voltage	24V DC, 110V AC, and 230V AC
Time Delay	0.1 s...30 min

##### Environmental & Physical Characteristics

Operating Temperature [C (F)]	0...40 ° (32...104 °)
Relative Humidity	95%
Shear Force to Key	15.1 k•N (3398 lbs), max.
Torque to Key	14 N•m (124 lb•in), max.
Material	Trapped key components: 316L stainless steel Face plate: 316L stainless steel Optional box: ABS plastic or stainless steel

3-Trapped Key  
Switches

#### The Prosafe Advantage



Stainless steel  
construction.

## Safety Switches Electronic Timed-Delay Units

### Product Selection

Type	Solenoid Voltage	Contact Set 1	Contact Set 2	Cat. No.
Single key out Panel mounted	24V DC	3 N.O. 40 A	1 N.O. 20 A	440T-MSTUE10*
		2 N.O. 20 A	1 N.C. 20 A	440T-MSTUE11*
	110V AC	3 N.O. 40 A	1 N.O. 20 A	440T-MSTUE20*
		2 N.O. 20 A	1 N.C. 20 A	440T-MSTUE22*
	230V AC	3 N.O. 40 A	1 N.O. 20 A	440T-MSTUE30*
		2 N.O. 20 A	1 N.C. 20 A	440T-MSTUE33*
Dual key out Panel mounted	24V DC	3 N.O. 40 A	1 N.O. 20 A	440T-MDTUE10**
		2 N.O. 20 A	1 N.C. 20 A	440T-MDTUE11**
	110V AC	3 N.O. 40 A	1 N.O. 20 A	440T-MDTUE20**
		2 N.O. 20 A	1 N.C. 20 A	440T-MDTUE22**
	230V AC	3 N.O. 40 A	1 N.O. 20 A	440T-MDTUE30**
		2 N.O. 20 A	1 N.C. 20 A	440T-MDTUE33**

\* Substitute the desired primary code for this symbol (key not included). See 3-107 for code selection.

### Accessories

Description	Additional Information	Cat. No.
Stainless steel key	3-140	440T-AKEYE10*
Stainless steel replacement code barrel with dust cap		440T-ASCBE14*
Stainless steel weatherproof replacement dust cap		440T-ASFC10*
Optional plastic enclosure	For use with 20 A units	440T-AIPB20
Optional stainless steel enclosure	For use with 40 A units	440T-AIPB23
	For use with all units	440T-AIPB46

\* Substitute the desired primary code for this symbol (key not included). See 3-107 for code selection.

### 3-Trapped Key Switches

### Approximate Dimensions [mm (in.)]

Dimensions are not intended to be used for installation purposes.

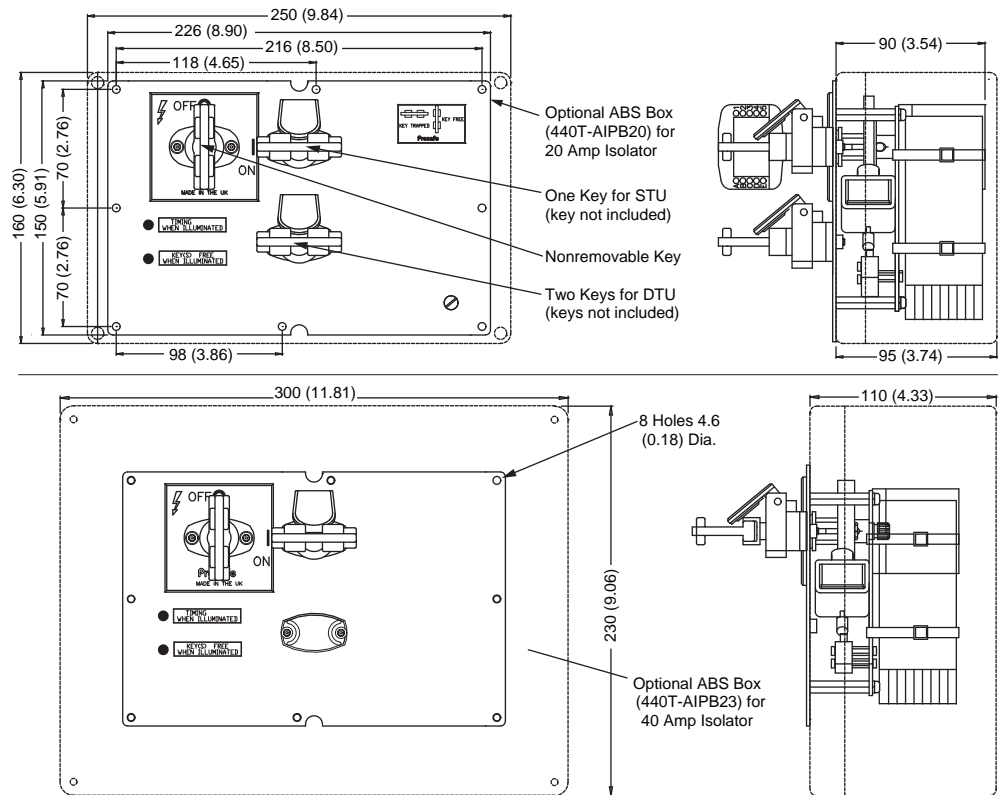

## Safety Switches

### Stopped Motion Units

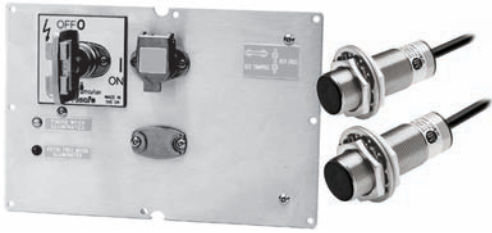

#### Description

The Stopped Motion Unit (SMU) is used in applications that require the detection of stopped motion of mechanical parts of a machine. The SMU uses inductive proximity sensors to detect motion and the CU2 control unit to monitor the sensors.

The CU2 requires a PNP and an NPN output type proximity sensors. When the proximity sensors stop detecting movement, the CU2 activates its output, powering an internal solenoid. With the solenoid energized, one or two trapped keys can be removed from the SMU.

The removable trapped keys (one or two) can be used to continue the next sequence in allowing access to the hazardous area.

See the CU2 control unit for details on setting the delay time.

Additional proximity sensors can be found in the Sensors catalog.

#### Features

- Stopped motion detection
- NPN and PNP proximity sensors
- Timed-delay output up to 40 minutes
- Category 1 Stop
- Replaceable code barrel assembly

#### Specifications

##### Safety Ratings

Standards	EN1954-1, IEC/EN60204-1, EN1088, IEC/EN60947-5-1, ISO13849-1, ISO12100-1&2, ISO14119, GS-ET-19, AS4024.1
Category	Cat. 3 per EN 954-1 (ISO 13849-1)
Certifications	CE Marked for all applicable directives and BG

##### Operating Characteristics

Electrical Life	100,000 operations
Mechanical Life	100,000 operations
Solenoid Voltage	24V DC, 110V AC, and 230V AC
Time Delay	0.1 s...40 min
Zero Speed Sensors	2x inductive sensors

##### Environmental & Physical Characteristics

Operating Temperature [C (F)]	0...40° (32...104°)
Relative Humidity	95%
Shear Force to Key	15.1 k•N (3398 lbs)
Torque to Key	14 N•m (124 lb•in)
Material	Trapped key components: 316L stainless steel Face plate: 316L stainless steel Optional box: ABS plastic or stainless steel Inductive sensors: stainless steel barrel, plastic face
Mounting	Tamper resistant screws
Weight	2.0 kg (4.4 lbs)

3-Trapped Key  
Switches

#### The Prosafe Advantage



Stainless steel  
construction.

## Safety Switches Stopped Motion Units

### Product Selection

Type	Solenoid Voltage	Contact Set 1	Contact Set 2	Cat. No.
Single key out Panel mounted	24V DC	3 N.O. 40 A	1 N.O. 20 A	440T-MSMSE10*
		2 N.O. 20 A	1 N.C. 20 A	440T-MSMSE11*
	110V AC	3 N.O. 40 A	1 N.O. 20 A	440T-MSMSE20*
		2 N.O. 20 A	1 N.C. 20 A	440T-MSMSE22*
	230V AC	3 N.O. 40 A	1 N.O. 20 A	440T-MSMSE30*
		2 N.O. 20 A	1 N.C. 20 A	440T-MSMSE33*
Dual key out Panel mounted	24V DC	3 N.O. 40 A	1 N.O. 20 A	440T-MDMSE10**
		2 N.O. 20 A	1 N.C. 20 A	440T-MDMSE11**
	110V AC	3 N.O. 40 A	1 N.O. 20 A	440T-MDMSE20**
		2 N.O. 20 A	1 N.C. 20 A	440T-MDMSE22**
	230V AC	3 N.O. 40 A	1 N.O. 20 A	440T-MDMSE30**
		2 N.O. 20 A	1 N.C. 20 A	440T-MDMSE33**

\* Substitute the desired primary code for this symbol (key not included). See 3-107 for code selection.

### Accessories

Description	Size [mm]	Type	Additional Information	Cat. No.
Stainless steel key	—	—	3-140	440T-AKEYE10*
Stainless steel replacement code barrel with dust cap				440T-ASCBE14*
Stainless steel weatherproof replacement dust cap				440T-ASFC10*
500 mA fuse—Bussmann Cat. No. ETF-500 mA	—	500 mA @ 250V	NA	440R-A31562
Optional plastic enclosure	—	—	For use with 20 A units	440T-AIPB20
Optional stainless steel enclosure			For use with 40 A units	440T-AIPB23
			For use with all units	440T-AIPB46
Inductive Proximity Sensor, Three-wire, DC	12	NPN	page 5-57	872C-D3NN12-E2
		PNP		872C-D3NP12-E2
	18	NPN		872C-D5NN18-E2
		PNP		872C-D5NP18-E2
	30	NPN		872C-D10NN30-E2
		PNP		<b>872C-D10NP30-E2</b>

\* Substitute the desired primary code for this symbol (key not included). See 3-107 for code selection.

3-Trapped Key  
Switches

### Approximate Dimensions [mm (in.)]

Dimensions are not intended to be used for installation purposes.

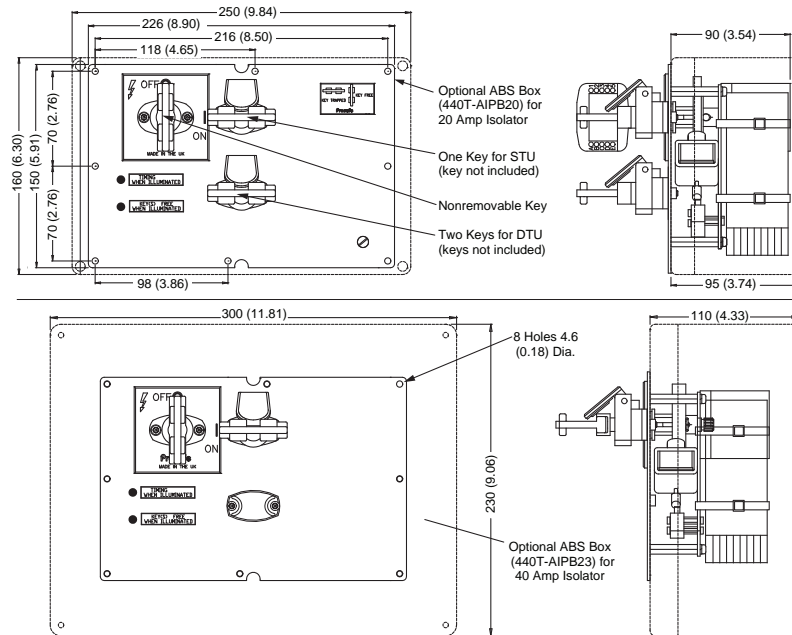



## Safety Switches Exchange Units

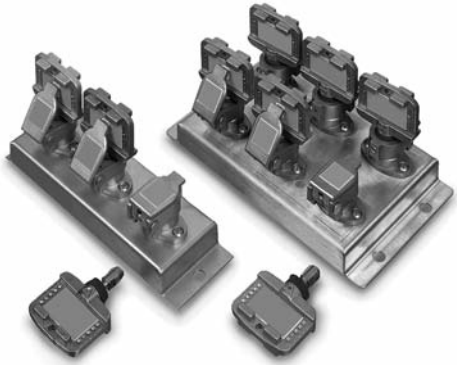

### Description

The key exchange unit (KEX) is used in an interlocking sequence to link together other devices in the Prosafe range and caters to more complex operating sequences.

The operating principle is such that no secondary keys can be removed from the unit until all primary keys have been inserted, rotated, and trapped. The primary keys remain trapped until all secondary keys have been re-inserted, rotated, and trapped.

It is typically used in applications where there is more than one access way to the hazardous area, and each access way must be open at the same time. The key exchange unit accomplishes this by allowing one or more keys to be inserted which then releases multiple keys out.

A typical process may require a rotary key switch to turn a motor off. The key from the rotary switch is removed and inserted into a KEX. The KEX then releases three keys which would allow simultaneous access to the hazard area through three different gates. This KEX is described as 1 key in 3 keys out. The keys in are considered primary codes, so the keys are not included in the KEX. The keys out are considered secondary codes, so the keys are included.

### Features

- A range of off-the-shelf units in various combinations
- 316L stainless steel construction
- Primary key(s) in release secondary keys simultaneously on units up to six ways
- Weatherproof stainless steel dust cap as standard
- Replaceable code barrel assembly

### Specifications

#### Safety Ratings

Standards	EN1088, ISO12100-1&2, ISO14119, AS4024.1
Category	Cat. 3 per EN 954-1 (ISO 13849-1) cULus and TÜV
Certifications	CE Marked for all applicable directives and BG; C-Tick not required

#### Operating Characteristics

Operating Temperature [C (F)]	-40...+200 ° (-40...+392 °)
Mechanical Life	100,000 operations

#### Environmental & Physical Characteristics

Shear Force to Key	15.1 k•N (3398 lbs), max.
Torque to Key	14 N•m (124 lb•in), max.
Relative Humidity	95%
Material	316L stainless steel

### Optional Key Exchange Cabinets

Number of Keys	Length [mm (in.)]	Width [mm (in.)]	Depth [mm (in.)]	Cat. No.
<b>Painted Mild Steel</b>				
7...11 way (max)	400 (15.7)	300 (11.8)	200 (7.87)	440T-AIPB30
12...15 way (max)	400 (15.7)	400 (15.7)	210 (8.26)	440T-AIPB33
16...25 way (max)	600 (23.6)	600 (23.6)	210 (8.26)	440T-AIPB34
<b>Stainless Steel</b>				
12...15 way (max)	400 (15.7)	400 (15.7)	210 (8.26)	440T-AIPB40
16...25 way (max)	600 (23.6)	600 (23.6)	210 (8.26)	440T-AIPB44

3-Trapped Key  
Switches

### The Prosafe Advantage



Stainless steel construction.

## Safety Switches Exchange Units

### Product Selection

Key Exchange Units		
Number of Keys	Keys In and Out	Cat. No.
2 way	1 key in 1 key out	440T-MKEXE10‡
3 way	1 key in 2 keys out	440T-MKEXE11‡
4 way	1 key in 3 keys out	440T-MKEXE12‡
5 way	1 key in 4 keys out	440T-MKEXE13‡
6 way	1 key in 5 keys out	440T-MKEXE14‡
4 way	2 key in 2 keys out	440T-MKEXE15‡
5 way	2 key in 3 keys out	440T-MKEXE16‡
6 way	2 key in 4 keys out	440T-MKEXE17‡
6 way	3 key in 3 keys out	440T-MKEXE18‡
7 way	1 key in 6 keys out	440T-MKEXE19‡
8 way	1 key in 7 keys out	440T-MKEXE20‡
9 way	1 key in 8 keys out	440T-MKEXE22‡
10 way	1 key in 9 keys out	440T-MKEXE23‡
11 way	1 key in 10 keys out	440T-MKEXE24‡
12 way	1 key in 11 keys out	440T-MKEXE25‡
13 way	1 key in 12 keys out	440T-MKEXE26‡
14 way	1 key in 13 keys out	440T-MKEXE27‡
15 way	1 key in 14 keys out	440T-MKEXE28‡
16 way	1 key in 15 keys out	440T-MKEXE29‡
17 way	1 key in 16 keys out	440T-MKEXE30‡
18 way	1 key in 17 keys out	440T-MKEXE33‡
19 way	1 key in 18 keys out	440T-MKEXE34‡
20 way	1 key in 19 keys out	440T-MKEXE35‡
21 way	1 key in 20 keys out	440T-MKEXE36‡
22 way	1 key in 21 keys out	440T-MKEXE37‡
23 way	1 key in 22 keys out	440T-MKEXE38‡
24 way	1 key in 23 keys out	440T-MKEXE39‡
25 way	1 key in 24 keys out	440T-MKEXE40‡

‡ Specify the codes individually for each primary key in (key not included) and for each secondary key (key included). See 3-107 for code selection.  
Consult factory for other configurations of keys in and keys out.

### Accessories

Description	Additional Information	Cat. No.
Stainless steel key		440T-AKEYE10*
Stainless steel replacement code barrel with dust cap	3-140	440T-ASCBE14*
Stainless steel weatherproof replacement dust cap		440T-ASFC10*
Optional Key Exchange Cabinet	Mild steel cabinet for 7-...11-way units	440T-AIPB30
	Mild steel cabinet for 12-...15-way units	440T-AIPB33
	Mild steel cabinet for 16-...25-way units	440T-AIPB34
	Stainless steel cabinet for 12-...15-way units	440T-AIPB40
	Stainless steel cabinet for 16-...25-way units	440T-AIPB44

\* Substitute the desired primary code for this symbol (key not included). See 3-107 for code selection.

### Approximate Dimensions [mm (in.)]

Dimensions are not intended to be used for installation purposes.

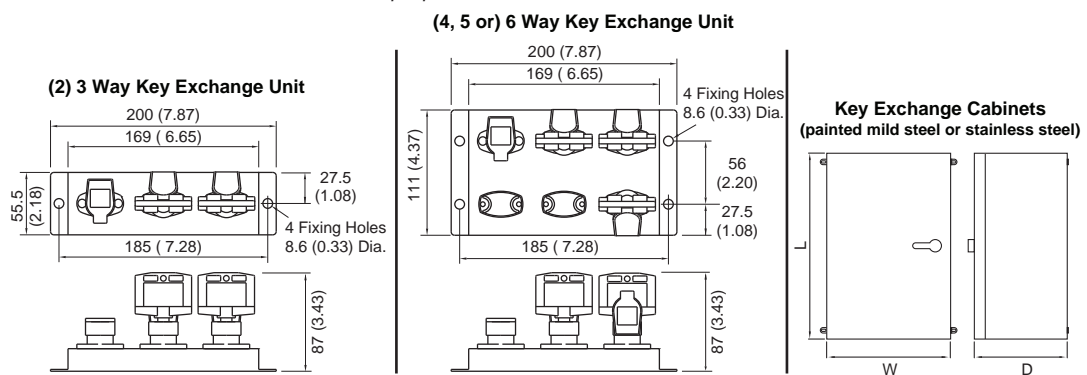

## Safety Switches

### Bolt Interlocks

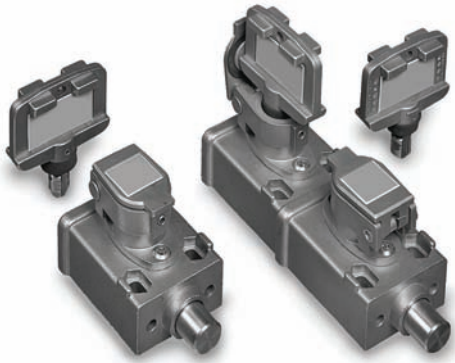

#### Description

The bolt interlocks are designed to allow access to hazardous areas when an appropriate key is inserted into the interlock. These bolt interlocks are manufactured in 316L stainless steel to provide a rugged, industrial grade method of helping prevent access through gates.

One advantage of the bolt interlocks is that there is no need to run power wires to the gate. Power is disconnected by a trapped key rotary switch on a control panel and the key is then hand-carried to the gate by the operator.

The Single Bolt interlock (SBL) is designed to be used to access hazardous areas where partial body exposure is required. The SBL is not shipped with a key. If two keys are needed for partial body access, select the Dual Bolt interlock (DBL) that requires both keys to be trapped to operate. This version of the DBL does not include the keys.

When whole body access is needed, the DBL, with one primary key and one secondary trapped key (included) should be used. The secondary key serves the function of a personnel key. This DBL allows the operator to carry the personnel key into the hazardous area. When the operator returns from the hazardous area and returns the personnel key to the DBL, the locking sequence can be reversed and the process re-started.

#### Features

- 316L stainless steel construction
- Various extensions of bolt
- Direct drive push/pull operation
- Replaceable code barrel assembly
- Fitted with tamper resistant screws
- Weatherproof stainless steel dust cap as standard
- Solenoid and electric versions
- Multiple key options

#### The Prosafe Advantage



Stainless steel construction.

#### Specifications

##### Safety Ratings

Standards	EN1088, ISO12100-1&2, ISO14119, AS4024.1
Category	Cat. 1 per EN 954-1 (ISO 13849-1) Suitable for Cat. 2, 3, or 4 systems
Certifications	CE Marked for all applicable directives and BG; C-Tick not required

##### Operating Characteristics

Operating Temperature [C (F)]	Mechanical: -40...+200 ° (-40...+392°) Electrical: -20...+80 ° (-4...+176 °) Solenoid: -20...+60 ° (-4...+140°)
Mechanical Life	100,000 operations

##### Environmental & Physical Characteristics

Shear Force to Key	15.1 k•N (3398 lbs), max.
Torque to Key	14 N•m (124 lb•in), max.
Relative Humidity	95%
Weight [kg (lbs)]	SBL: 0.60 (1.32) DBL: 1.10 (2.43)
Material	316L stainless steel
Mounting	SBL: 2 x M5 counterbored from top or 2 x M5 from underside with M5 nuts DBL: 4 x M5 counterbored from top or 4 x M5 from underside with M5 nuts
Bolt Diameter	15 mm (0.59 in.)

3-Trapped Key  
Switches

## Safety Switches Bolt Interlocks

### Product Selection - Mechanical

Type	Trapped Key Condition	Bolt Retracted [mm (in.)]	Bolt Extended [mm (in.)]	Cat. No.
Single key	Key trapped to retract bolt	0	14 (0.55)	440T-MSBLE10*
		3 (0.11)	17 (0.66)	440T-MSBLE11*
		6 (0.23)	20 (0.78)	440T-MSBLE12*
		13 (0.51)	27 (1.06)	440T-MSBLE13*
Dual key	Both keys trapped to retract bolt	0	14 (0.55)	440T-MDBLE10**
		3 (0.11)	17 (0.66)	440T-MDBLE11**
		6 (0.23)	20 (0.78)	440T-MDBLE12**
		13 (0.51)	27 (1.06)	440T-MDBLE13**
	Primary key trapped, secondary key free to retract bolt	0	14 (0.55)	440T-MDBLE14*⊗
		3 (0.11)	17 (0.66)	440T-MDBLE15*⊗
		6 (0.23)	20 (0.78)	440T-MDBLE16*⊗
		13 (0.51)	27 (1.06)	440T-MDBLE17*⊗
Dual Key with Secondary Ejector Key		0	14 (0.55)	440T-MDBLJ14*⊗
		3 (0.11)	17 (0.66)	440T-MDBLJ15*⊗
		6 (0.23)	20 (0.78)	440T-MDBLJ16*⊗
		13 (0.51)	20 (0.78)	440T-MDBLJ17*⊗
Triple key	Three keys trapped to retract bolt	0	14 (0.55)	440T-MTBLE10***
		3 (0.11)	17 (0.66)	440T-MTBLE11***
		6 (0.23)	20 (0.78)	440T-MTBLE12***
		13 (0.51)	27 (1.06)	440T-MTBLE13***
	Two primary trapped, one secondary key free to retract bolt	0	14 (0.55)	440T-MTBLE14**⊗
		3 (0.11)	17 (0.66)	440T-MTBLE15**⊗
		6 (0.23)	20 (0.78)	440T-MTBLE16**⊗
		13 (0.51)	27 (1.06)	440T-MTBLE17**⊗
	One primary trapped, two secondary keys free to retract bolt	0	14 (0.55)	440T-MTBLE18*⊗⊗
		3 (0.11)	17 (0.66)	440T-MTBLE19*⊗⊗
		6 (0.23)	20 (0.78)	440T-MTBLE20*⊗⊗
		13 (0.51)	27 (1.06)	440T-MTBLE21*⊗⊗
Quad key	Four keys trapped to retract bolt	0	14 (0.55)	440T-MQBLE10****
		3 (0.11)	17 (0.66)	440T-MQBLE11****
		6 (0.23)	20 (0.78)	440T-MQBLE12****
		13 (0.51)	27 (1.06)	440T-MQBLE13****
	Three primary trapped, one secondary key free to retract bolt	0	14 (0.55)	440T-MQBLE14***⊗
		3 (0.11)	17 (0.66)	440T-MQBLE15***⊗
		6 (0.23)	20 (0.78)	440T-MQBLE16***⊗
		13 (0.51)	27 (1.06)	440T-MQBLE17***⊗

\* Substitute the desired primary code for this symbol (key not included). See 3-107 for code selection.

⊗ Substitute the desired secondary code for this symbol (key included). See 3-107 for code selection.

### Product Selection - Electrical

Contact Type	Type	Trapped Key Condition	Bolt Retracted [mm (in.)]	Bolt Extended [mm (in.)]	Cat. No.
2 N.C. & 1 N.O. break before make	Single key	Free key to retract bolt	0	14 (0.55)	440T-MSBSE10*
			3 (0.11)	17 (0.66)	440T-MSBSE11*
			6 (0.23)	20 (0.78)	440T-MSBSE12*
			13 (0.51)	27 (1.06)	440T-MSBSE13*
		Key trapped to retract bolt	0	14 (0.55)	440T-MSBSE33*
			3 (0.11)	17 (0.66)	440T-MSBSE34*
			6 (0.23)	20 (0.78)	440T-MSBSE35*
			13 (0.51)	27 (1.06)	440T-MSBSE36*
	Dual key	Both keys trapped to retract bolt	0	14 (0.55)	440T-MDBSE10**
			3 (0.11)	17 (0.66)	440T-MDBSE11**
			6 (0.23)	20 (0.78)	440T-MDBSE12**
			13 (0.51)	27 (1.06)	440T-MDBSE13**
		Primary key trapped, secondary key free to retract bolt	0	14 (0.55)	440T-MDBSE14*⊗
			3 (0.11)	17 (0.66)	440T-MDBSE15*⊗
			6 (0.23)	20 (0.78)	440T-MDBSE16*⊗
			13 (0.51)	27 (1.06)	440T-MDBSE17*⊗

\* Substitute the desired primary code for this symbol (key not included). See 3-107 for code selection.

⊗ Substitute the desired secondary code for this symbol (key included). See 3-107 for code selection.

## Safety Switches Bolt Interlocks

### Product Selection - Solenoid

Solenoid Voltage	Contact Type	Type	Trapped Key Condition	Bolt Retracted [mm (in.)]	Bolt Extended [mm (in.)]	Cat. No.
24V DC	2 N.C. & 1 N.O. break before make	Single key	Free key to retract bolt	0	14 (0.55)	440T-MSBUE10*
				3 (0.11)	17 (0.66)	440T-MSBUE11*
				6 (0.23)	20 (0.78)	440T-MSBUE12*
				13 (0.51)	27 (1.06)	440T-MSBUE13*
			Key trapped to retract bolt	0	14 (0.55)	440T-MSBUE33*
				3 (0.11)	17 (0.66)	440T-MSBUE34*
		Dual key	Both keys trapped to retract bolt	6 (0.23)	20 (0.78)	440T-MSBUE35*
				13 (0.51)	27 (1.06)	440T-MSBUE36*
				0	14 (0.55)	440T-MDBUE10**
			Both keys trapped to retract bolt	3 (0.11)	17 (0.66)	440T-MDBUE11**
				6 (0.23)	20 (0.78)	440T-MDBUE12**
				13 (0.51)	27 (1.06)	440T-MDBUE13**
			Primary key trapped, secondary key free to retract bolt	0	14 (0.55)	440T-MDBUE14*⊗
				3 (0.11)	17 (0.66)	440T-MDBUE15*⊗
				6 (0.23)	20 (0.78)	440T-MDBUE16*⊗
				13 (0.51)	27 (1.06)	440T-MDBUE17*⊗

\* Substitute the desired primary code for this symbol (key not included). See 3-107 for code selection.

⊗ Substitute the desired secondary code for this symbol (key included). See 3-107 for code selection.

### Accessories

Description	Additional Information	Cat. No.
Stainless steel key	3-140	440T-AKEYE10*
Stainless steel replacement code barrel with dust cap		440T-ASCBE14*
Stainless steel weatherproof replacement dust cap		440T-ASFC10*
Stainless steel ejector key		440T-AKEYE13*

\* Substitute the desired primary code for this symbol (key not included). See 3-107 for code selection.

### Approximate Dimensions [mm (in.)]

Dimensions are not intended to be used for installation purposes.

#### MSBLE10, 11, 12, and 13

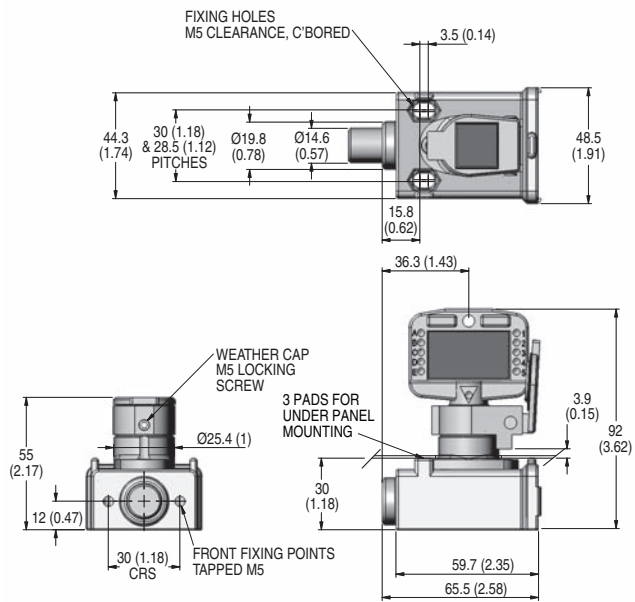

#### MDBLE10, 11, 12, and 13

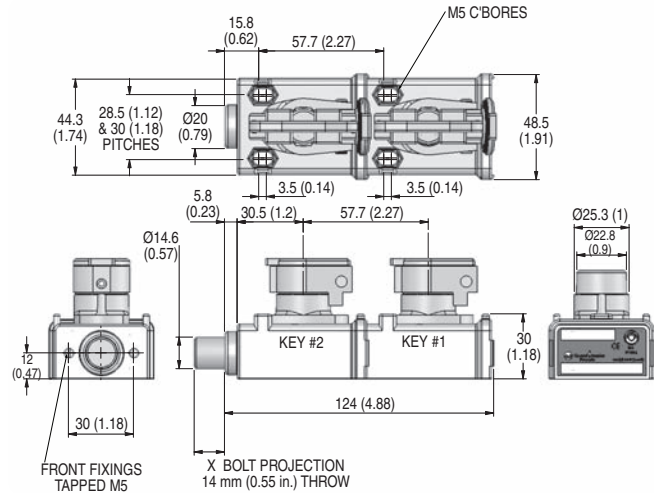

Type	X [mm (in.)]
440T-MDBLE10	0 (0)
440T-MDBLE11	3 (0.12)
440T-MDBLE12	6 (0.24)
440T-MDBLE13	13 (0.51)

3-Trapped Key Switches

## Safety Switches Bolt Interlocks

### Approximate Dimensions [mm (in.)] (continued)

Dimensions are not intended to be used for installation purposes.

#### MDBLE14, 15, 16, and 17

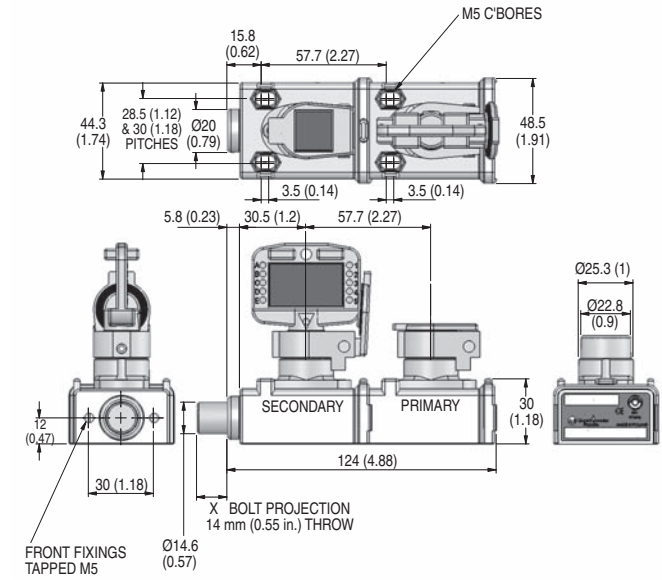

Type	X [mm (in.)]
440T-MDBLE14	0 (0)
440T-MDBLE15	3 (0.12)
440T-MDBLE16	6 (0.24)
440T-MDBLE17	13 (0.51)

#### MTBLE10, 11, 12, and 13

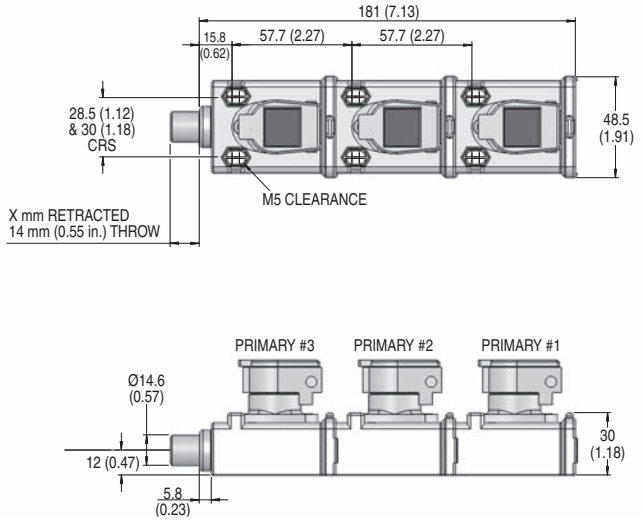

Type	X [mm (in.)]
440T-MTBLE10	0 (0)
440T-MTBLE11	3 (0.12)
440T-MTBLE12	6 (0.24)
440T-MTBLE13	13 (0.51)

#### MQBLE10, 11, 12, and 13

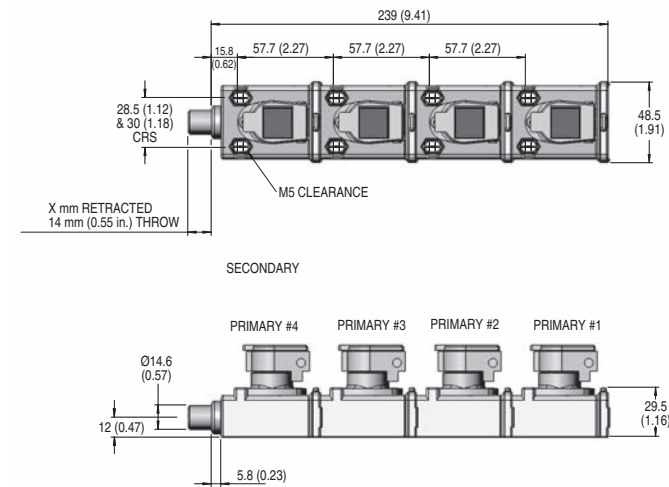

Type	X [mm (in.)]
440T-MQBLE10	0 (0)
440T-MQBLE11	3 (0.12)
440T-MQBLE12	6 (0.24)
440T-MQBLE13	13 (0.51)

#### MSBSE10, 11, 12, and 13

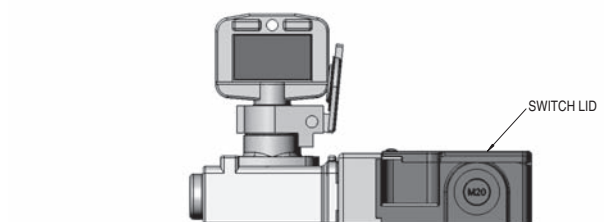
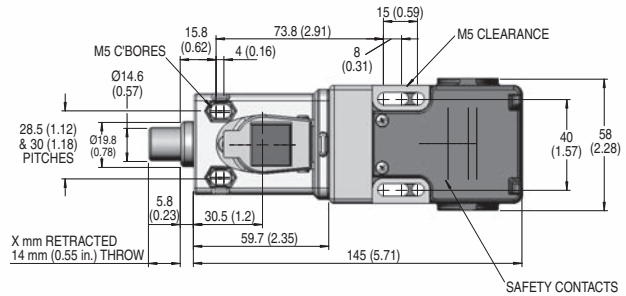

Type	X [mm (in.)]
440T-MSBSE10	0 (0)
440T-MSBSE11	3 (0.12)
440T-MSBSE12	6 (0.24)
440T-MSBSE13	13 (0.51)

3-Trapped Key  
Switches

## Safety Switches Bolt Interlocks

### Approximate Dimensions [mm (in.)] (continued)

Dimensions are not intended to be used for installation purposes.

#### MDBSE10, 11, 12, and 13

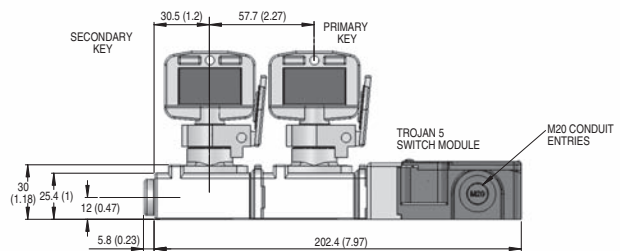
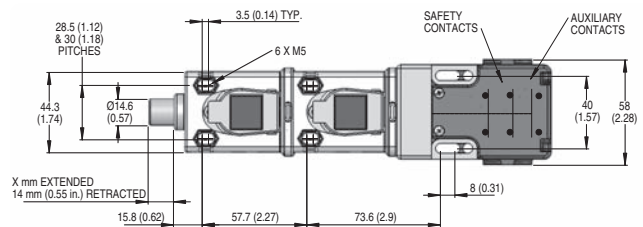

Type	X [mm (in.)]
440T-MDBSE10	0 (0)
440T-MDBSE11	3 (0.12)
440T-MDBSE12	6 (0.24)
440T-MDBSE13	13 (0.51)

#### MSBUE33, 34, 35, and 36

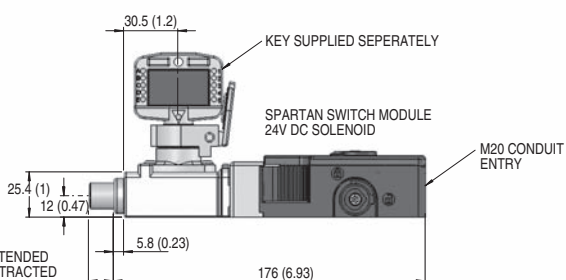
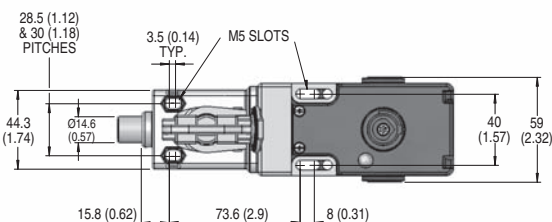

Type	X [mm (in.)]	Y [mm (in.)]
440T-MSBUE33	14 (0.55)	0 (0)
440T-MSBUE34	17 (0.67)	3 (0.12)
440T-MSBUE35	20 (0.79)	6 (0.24)
440T-MSBUE36	27 (1.06)	13 (0.51)

#### MDBUE14, 15, 16, and 17

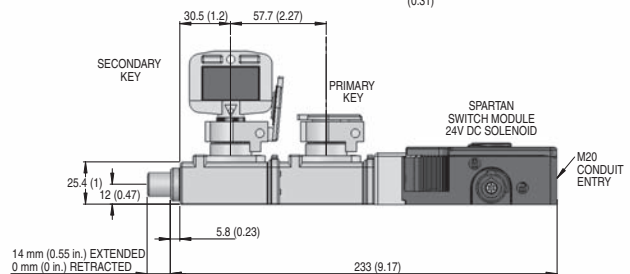
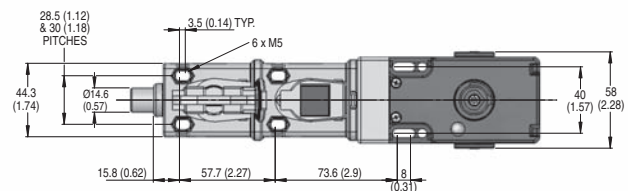

3-Trapped Key  
Switches

## Safety Switches

### Access/Chain Interlocks

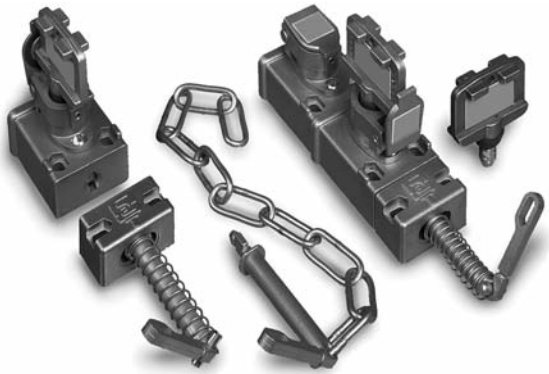

#### Description

The access interlocks are designed to allow access to hazardous areas when an appropriate key is inserted into the interlock. These access interlocks are manufactured in 316L stainless steel to provide rugged, industrial grade method of helping prevent access through gates. They are actuated by either a lever or a rod which is connected to chain.

One advantage of the access interlocks is that there is no need to run power wires to the gate. Power is disconnected by a trapped key rotary switch on a control panel and the key is then hand-carried to the gate by the operator.

The Single-key Access Lock (SAL) and Single-key Chain Lock (SCL) are designed to be used to access hazardous areas where partial body exposure is required. If two keys are needed for partial body access, select the Dual-key Access Lock (DAL) or Dual-key Chain Lock (DCL) with both keys trapped.

When whole body access is needed, the DAL or DCL, with one key trapped and one key free should be used. The secondary key serves the function of a personnel key. The DAL and DCL allow the operator to carry the personnel key into the hazardous area. When the operator returns from the hazardous area and returns the personnel key to the DAL or DCL, the locking sequence can be reversed and the process restarted.

#### Features

- 316L stainless steel construction
- Direct drive operation
- Fitted with tamper resistant screws
- Stainless steel dust cap as standard
- Replaceable code barrel assembly
- Solenoid and electric versions
- Multiple key options

#### The Prosafe Advantage



Stainless steel construction.

#### Specifications

##### Safety Ratings

Standards	EN1088, ISO12100-1&2, ISO14119, AS4024.1
Category	Cat. 1 per EN 954-1 (ISO 13849-1) Suitable for Cat. 2, 3, or 4 systems
Certifications	CE Marked for all applicable directives and BG; C-Tick not required

##### Operating Characteristics

Operating Temperature [C (F)]	Mechanical: -40...+200 ° (-40...+392 °) Electrical: -20...+80 ° (-4...+176 °) Solenoid: -20...+60 ° (-4...+140 °)
Relative Humidity	95%
Mechanical Life	100,000 operations

##### Physical Characteristics

Misalignment Tolerance	±10 mm (0.39 in.)
Shear Force to Key	15.1 k•N (3398 lbs), max.
Torque to Key	14 N•m (124 lb•in), max.
Material	316L stainless steel
Mounting	SAL and SCL: 2 or 4 x M5 counterbored from top or 2 or 4 x M5 from underside with nuts DAL and DCL: 4 or 6 x M5 counterbored from top or 4 or 6 x M5 from underside with nuts
Weight [kg (lbs)]	SAL and SCL: 0.8 (1.8) DAL and DCL: 1.35 (3)



## Safety Switches Access/Chain Interlocks

### Product Selection - Mechanical

Type	Actuator Type	Trapped Key Condition	Cat. No.
Single key	Lever	Key trapped to release lever	440T-MSALE10*
	Chain	Key trapped to release chain	440T-MSCLE10*
	Extended Lever	Key trapped to release lever	440T-MSALE20*
Single key with padlock hasp	Lever	Key trapped to release lever	440T-MSALE11*
	Chain	Key trapped to release chain	440T-MSCLE11*
Dual key	Lever	Primary key trapped, secondary key free to release lever	440T-MDALE10*⊗
		Both keys trapped to release lever	440T-MDALE11**
	Chain	Primary key trapped, secondary key free to release chain	440T-MDCLE10*⊗
		Both keys trapped to release chain	440T-MDCLE11**
Dual key with padlock hasp	Lever	Primary key trapped, secondary key free to release lever	440T-MDALE45*⊗
Dual key with eject key	Lever	Primary key trapped, secondary spring eject key	440T-MDALJ10*⊗
	Chain		440T-MDCLJ10*⊗
Triple key	Lever	One primary trapped, two secondary keys free to release lever	440T-MTALE11*⊗⊗
	Chain	One primary trapped, two secondary keys free to release chain	440T-MTCLE11*⊗⊗

\* Substitute the desired primary code for this symbol (key not included). See 3-107 for code selection.

⊗ Substitute the desired secondary code for this symbol (key included). See 3-107 for code selection.

### Product Selection - Electrical

Contact Type	Type	Actuator Type	Trapped Key Condition	Cat. No.
2 N.C. & 1 N.O. break before make	Dual Key	Lever	Both keys trapped to release lever	440T-MDASE21**
			Primary key trapped, secondary key free to release lever	440T-MDASE20*⊗
		Chain	Both keys trapped to release chain	440T-MDCSE21**
			Primary key trapped, secondary key free to release chain	440T-MDCSE20*⊗

\* Substitute the desired primary code for this symbol (key not included). See 3-107 for code selection.

⊗ Substitute the desired secondary code for this symbol (key included). See 3-107 for code selection.

### Accessories

Description	Additional Information	Cat. No.
Stainless steel key	3-140	440T-AKEYE10*
Stainless steel replacement code barrel with dust cap		440T-ASCBE14*
Stainless steel weatherproof replacement dust cap		440T-ASFC10*
Replacement actuator type lever	—	440T-ACAD10
Replacement actuator type chain	—	440T-ACHA10
Stainless steel ejector key	—	440T-AKEYE13*

\* Substitute the desired primary code for this symbol (key not included). See 3-107 for code selection.

3-Trapped Key  
Switches

## Safety Switches Access/Chain Interlocks

### Approximate Dimensions [mm (in.)]

Dimensions not intended to be used for installation purposes.

#### MSALE10

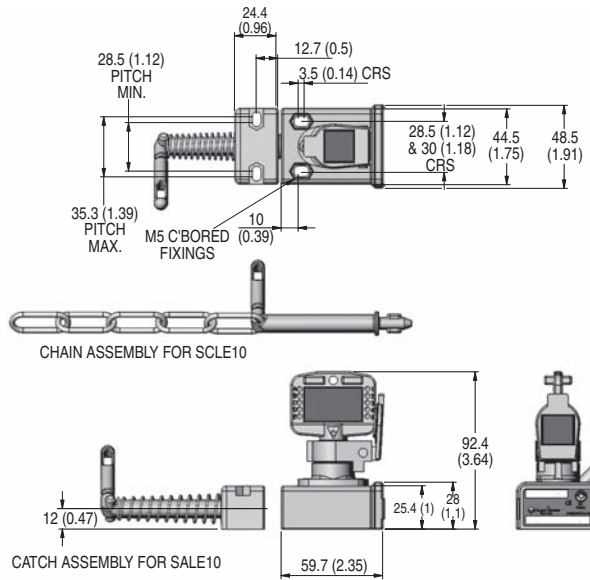

#### MSALE11

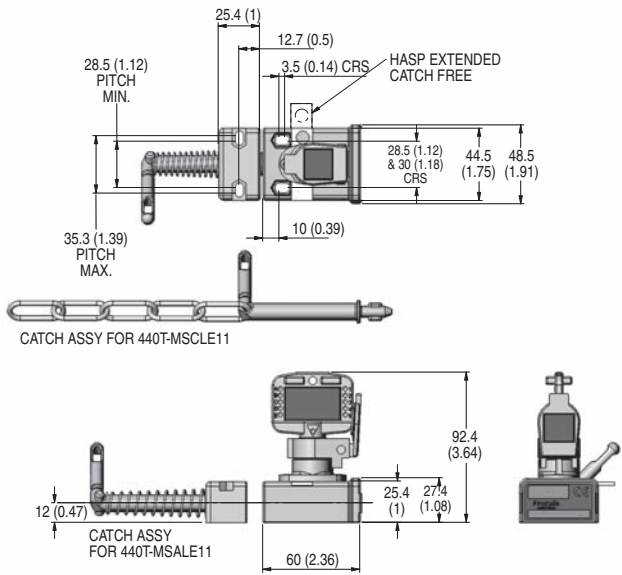

#### MDALE10 and MDCLE10

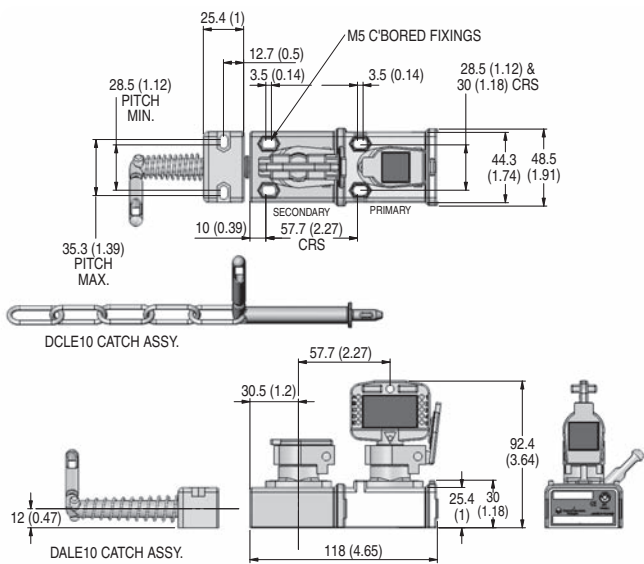

#### MDALE11

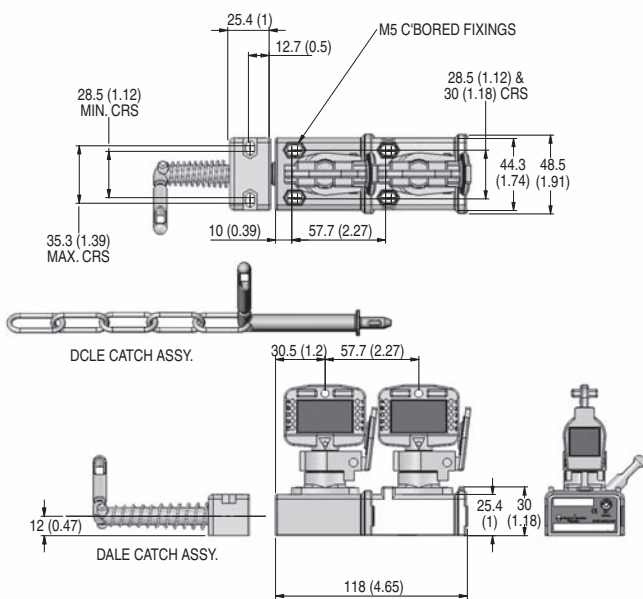

3-Trapped Key  
Switches

## Safety Switches Access/Chain Interlocks

### Approximate Dimensions [mm (in.)] (continued)

Dimensions not intended to be used for installation purposes.

#### MDALE45

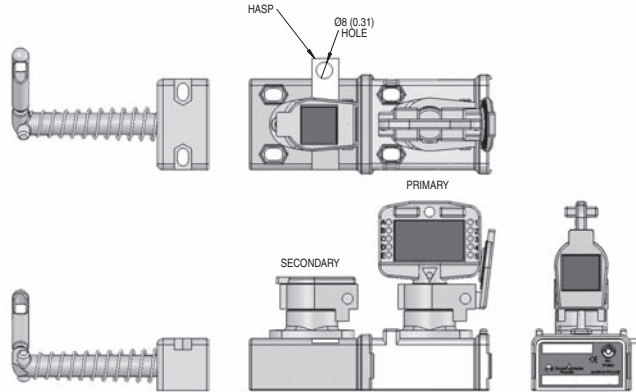

#### MTALE11

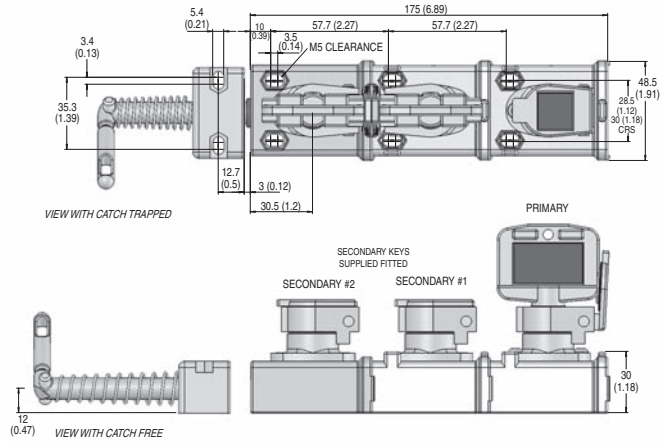

#### MTCLE11

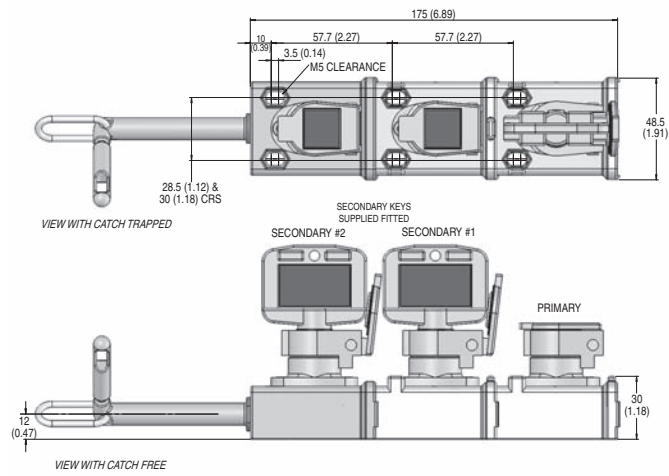

3-Trapped Key  
Switches

## Safety Switches

### Slamlock Mechanical

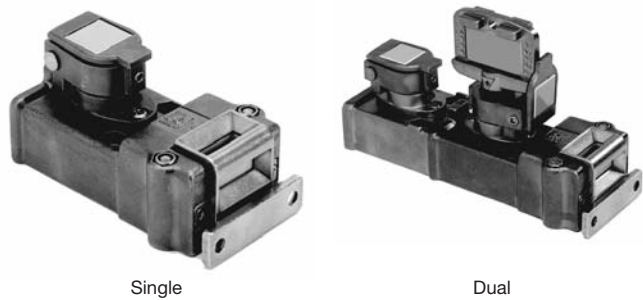

Single

Dual

#### Description

The Prosafe Slamlock combines the features of trapped keys with tongue actuated interlocks. When the actuator is inserted into the interlock (guard closed), the trapped key can be rotated and removed. With the key free, the actuator can not be removed thus locking closed the guard door. The trapped key must be re-inserted and rotated 90° to unlock the guard.

Slamlocks are manufactured in 316L stainless steel to provide a rugged, industrial grade method of interlocking guard doors.

One advantage of the slamlock is that there is no need to run power wires to the gate. Power is disconnected by a trapped key on a control panel or by a Prosafe RKS type unit and the key is then hand-carried to the gate by the operator.

The Single-key Slamlock (SSL) is used to interlock hatches, guards and doors where full body access is not required.

Dual-key Slamlock (DSL) is similar to the single key version but has a secondary key to allow "two key in" or "key exchange" conditions. The key exchange version may be used where whole body access is required, as the secondary key can be used as a personnel key.

#### Features

- 316L stainless steel construction
- Selection of actuator types available
- Direct drive operation
- Replaceable code barrel assembly
- Fitted with tamper resistant screws
- Weatherproof stainless steel dust cap as standard
- Multiple key options

#### Specifications

##### Safety Ratings

Standards	EN1088, IEC/EN60947-5-1, GS-ET-19, ISO12100-1&2, ISO14119, AS4024.1
Category	Cat. 1 per EN 954-1 (ISO 13849-1) Suitable for Cat. 2, 3, or 4 systems
Certifications	CE Marked for all applicable directives and BG; C-Tick not required

##### Operating Characteristics

Operating Temperature [C (F)]	-40...+200 ° (-40...+392 °)
Mechanical Life	In excess of 100,000 operations under normal working conditions
Code Barrel Life	Tested to 100,000 operations

##### Environmental & Physical Characteristics

Shear Force to Key	15.1 k•N (3398 lbs), max.
Torque to Key	14 N•m (124 lb•in), max.
Relative Humidity	95%
Weight [kg (lbs)]	Single Key: 0.76 (1.68) Dual Key: 1.33 (2.93)
Ambient Temperature [C (F)]	-10...+50 ° (14...122 °)
Material	316L stainless steel
Mounting	SSL: 2 x M5 counterbored from top or 2 x M5 from underside with nuts DSS: 4 x M5 counterbored from top or 4 x M5 from underside with nuts
Holding Force, Max.	2000 N (450 lbs)

#### The Prosafe Advantage



Stainless steel construction.

## Safety Switches Slamlock Mechanical

### Product Selection

Type	Actuator Type	Trapped Key Condition	Cat. No.
Single key	Standard	Key trapped to release actuator	440T-MSSLE10*
	Flexible		440T-MSSLE11*
	Flat		440T-MSSLE12*
Dual key	Standard	Primary key trapped, secondary key free to release actuator	440T-MDSLE10*⊗
	Flexible		440T-MDSLE11*⊗
	Flat		440T-MDSLE12*⊗
	Standard	Both keys trapped to release actuator	440T-MDSLE20**
	Flexible		440T-MDSLE22**
	Flat		440T-MDSLE23**
Dual with secondary ejector key	Standard	Primary key trapped, secondary key free to release actuator	440T-MDSLJ10*⊗
	Flexible		440T-MDSLJ11*⊗
	Flat		440T-MDSLJ12*⊗

\* Substitute the desired primary code for this symbol (key not included). See 3-107 for code selection.  
 ⊗ Substitute the desired secondary code for this symbol (key included). See 3-107 for code selection.

### Accessories

Description	Additional Information	Cat. No.
Stainless steel key	3-140	440T-AKEYE10⊗
Stainless steel ejector key		440T-AKEYE13⊗
Stainless steel replacement code barrel with dust cap		440T-ASCBE14*
Stainless steel weatherproof replacement dust cap		440T-ASFC10⊗
GD2 standard actuator	—	440G-A27011
GD2 flat actuator	—	440K-A11112
Fully flex actuator	—	440G-A27143

\* Substitute the desired primary code for this symbol (key not included). See 3-107 for code selection.  
 ⊗ Substitute the desired code for this symbol. See 3-107 for code selection.

### Approximate Dimensions [mm (in.)]

Dimensions are not intended to be used for installation purposes.

#### Single Key Slamlock

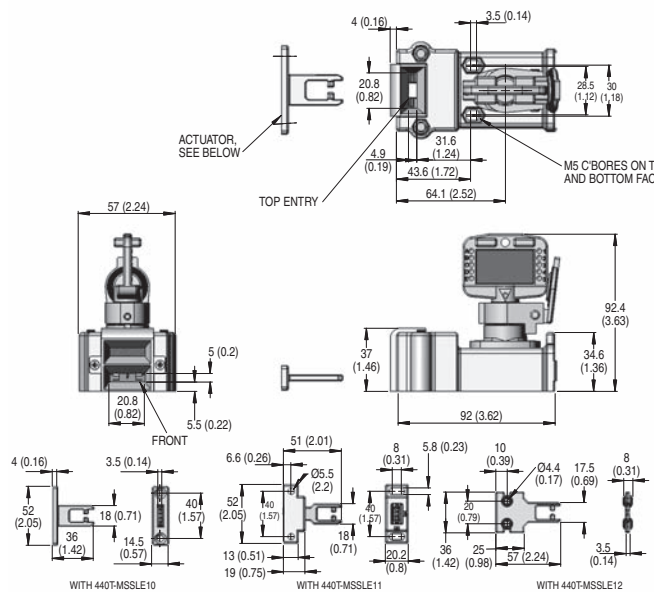

#### Dual Key Slamlock

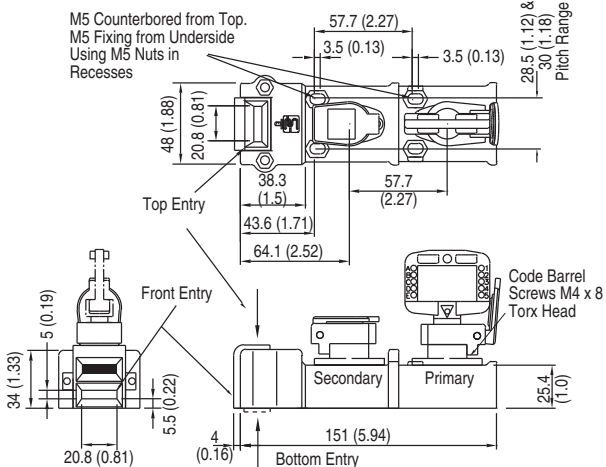

#### Flat Actuator

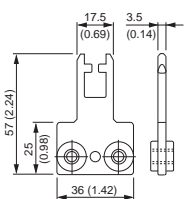

#### Flexible/Adjustable Actuator

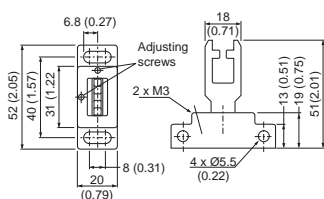

#### Standard Actuator

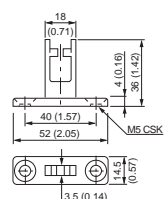

3-Trapped Key Switches

## Safety Switches

### Slamlock Electrical

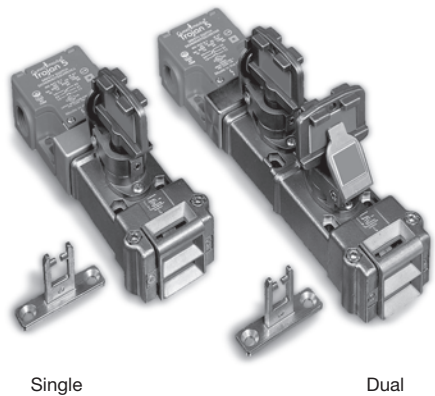

Single

Dual

#### Description

The Prosafe Slamlock with electrical isolation combines the features of trapped key tongue actuated interlocks while also providing sets of electrical safety and auxiliary contacts. When the actuator is inserted into the lock and the key is removed the actuator is trapped in the unit thus locking closed the guard door. In this state the safety contacts are closed and the auxiliary contacts are open. To open the guard door the key must be inserted and rotated 90°, opening the safety contacts, closing the auxiliary contacts and enabling the actuator to be released thus unlocking the guard door. While the guard door is open the key is trapped in the unit.

Slamlocks with electrical isolation offer the features of electrical safety interlock switches with the benefits of a trapped key/enforced sequence systems. They allow a combination of both approaches for safeguarding machinery and processes to be used.

The Single-key Slamlock (SSS) is used to interlock hatches, guards and doors where full body access is not required. The single key locks the actuator and operates the switch in the same action.

Dual-key Slamlock (DSS) is similar to the single key version but has a secondary key to allow "two key in" or "key exchange" conditions. The key exchange version may be used where whole body access is required, as the secondary key can be used as a personnel key.

#### Features

- Electrical safety contacts combined with trapped key/enforced sequence feature
- Most of unit constructed from 316L stainless steel
- Selection of actuator types available
- Single or dual key versions available
- Direct drive operation
- Replaceable code barrel assembly
- Weatherproof stainless steel dust cap as standard
- Solenoid versions

#### The Prosafe Advantage



Stainless steel construction.

#### Specifications

##### Safety Ratings

Standards	EN1088, IEC/EN60947-5-1, GS-ET-19, ISO12100-1&2, ISO14119, AS4024.1
Category	Cat. 1 per EN 954-1 (ISO 13849-1) Suitable for Cat. 2, 3, or 4 systems
Certifications	CE Marked for all applicable directives and BG; C-Tick not required

##### Outputs

Safety Contacts	2 N.C. positive break
Switching Current @ Voltage, Max.	500V/500V A
Thermal Current (Ith)	10 A
Current, Min.	5 mA @ 5V DC
Safety Contact Gap	>2 x 2 mm (0.07 in.)
Rated Insulation Voltage	(Ui) 500V
Rated Impulse withstand Voltage	(Uimp) 2500V
Auxiliary Contacts	1 N.O.

##### Operating Characteristics

Break Contact Force, Min.	12 N (2.7 lbs)
Actuation Speed, Max.	1 ms
Actuation Frequency, Max.	2 cycle/s

##### Utilization Category

AC 15	(Ue)	500V	250V	100V
	(Ie)	1 A	2 A	5 A
DC		250V	0.5 A, 24V	2 A

##### Environmental Characteristics

Enclosure Type Rating	IP67
Operating Temperature [C (F)]	Electrical: -20...+80 ° (-4...+176°) Solenoid: -20...+60 ° (-4...+140 °)
Relative Humidity	95%

##### Physical Characteristics

Actuator Travel for Positive Opening	5 mm (0.19 in.)
Operating Radius, Min.	175 mm (6.88 in.) [60 mm (2.36 in.) with flexible actuator]
Actuator Holding Force, Max.	2000 N (450 lbs)
Releasable Load, Max.	100 N (22.5 lbs)
Case Material	UL Approved glass-filled polyester & 316L stainless steel
Actuator Material	Stainless steel
Conduit Entry	3 x M20
Mounting	SSS: 4 x M5 counterbored from top or 4 x M5 from underside with nuts DSS: 6 x M5 counterbored from top or 6 x M5 from underside with nuts
Mechanical Life	100,000 operations
Electrical Life	1,000,000 operations
Weight [g (lbs)]	SSE: 1160 (2.6) DSSE: 1700 (3.7)
Color	Red/Stainless
Shear Force to Key	15.1 k•N (3398 lbs), max.
Pollution Degree	3
Torque to Key	14 N•m (124 lb•in), max.

**Note:** The safety contacts of the Guardmaster switches are described as normally closed (N.C.), i.e. with the guard closed, actuator in place (where relevant) and the machine able to be started.

## Safety Switches Slamlock Electrical

### Product Selection - Electrical

Contact Type	Type	Trapped Key Condition	Actuator Type	Cat. No.
2 N.C. + 1 N.O. Break before make	Single key	Key trapped to release actuator	Standard	440T-MSSSE10*
			Flexible	440T-MSSSE11*
			Flat	440T-MSSSE12*
		Key free to release actuator	Standard	440T-MSSSE20*
			Flexible	440T-MSSSE22*
			Flat	440T-MSSSE23*
	Dual key	Primary key trapped, secondary key free to release actuator	Standard	440T-MDSSE10*⊗
				440T-MDSSJ10*⊗
		Primary key trapped, secondary key eject to release actuator	Flexible	440T-MDSSE11*⊗
				440T-MDSSJ11*⊗
		Primary key trapped, secondary key free to release actuator	Flat	440T-MDSSE12*⊗
				440T-MDSSJ12*⊗
Both keys free to release actuator	Standard	440T-MDSSE20**		
	Flexible	440T-MDSSE22**		
	Flat	440T-MDSSE23**		
2 N.C. + 2 N.O. Break before make	Single key	Key free to release actuator	Standard	440T-MSSSE26*
			Flexible	440T-MSSSE27*
			Flat	440T-MSSSE25*

\* Substitute the desired primary code for this symbol (key not included). See 3-107 for code selection.  
 ⊗ Substitute the desired secondary code for this symbol (key included). See 3-107 for code selection.

### Product Selection - Solenoid

Contact Type	Type	Trapped Key Condition	Solenoid Voltage	Actuator Type	Cat. No.
2 N.C. & 1 N.O. Break before make	Single key	Key free to release actuator	24V DC	Standard	440T-MSSUE20*
				Flexible	440T-MSSUE22*
				Flat	440T-MSSUE23*
	Dual key	Primary key trapped, secondary key free to release actuator	24V DC	Standard	440T-MDSUE10*
				Flexible	440T-MDSUE11*
				Flat	440T-MSSUE12*
Single key	Key free to release actuator	110V AC	Standard	440T-MSSUE50*	

\* Substitute the desired primary code for this symbol (key not included). See 3-107 for code selection.

### Approximate Dimensions [mm (in.)]

Dimensions are not intended to be used for installation purposes.

#### Single Key Slamlock

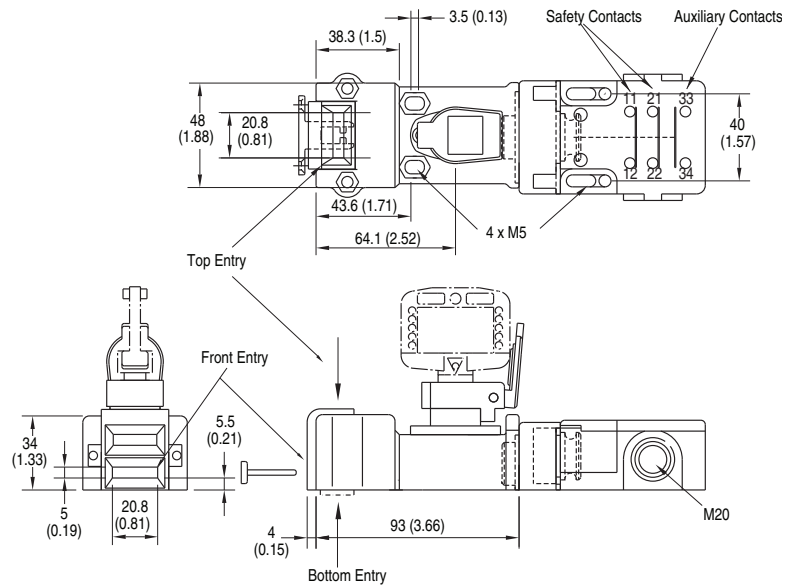

3-Trapped Key Switches

## Safety Switches Slamlock Electrical

### Approximate Dimensions [mm (in.)] (continued)

Dimensions are not intended to be used for installation purposes.

#### Dual Key Slamlock

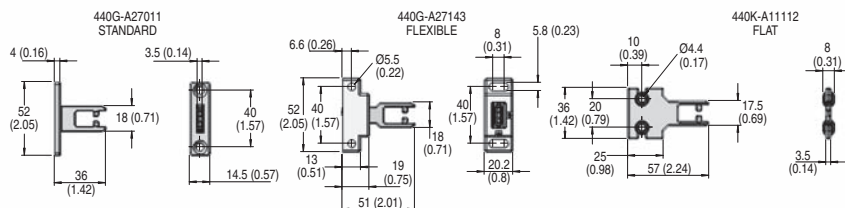
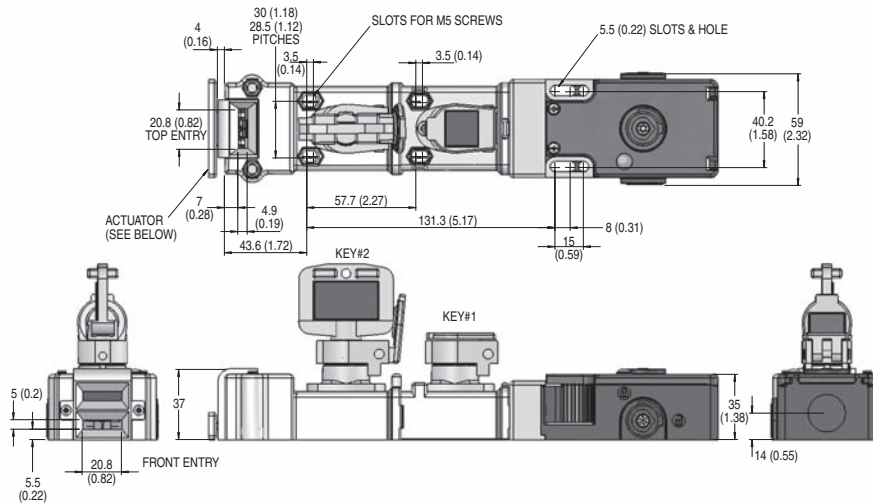
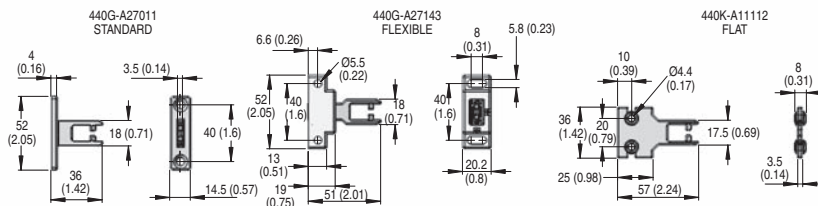
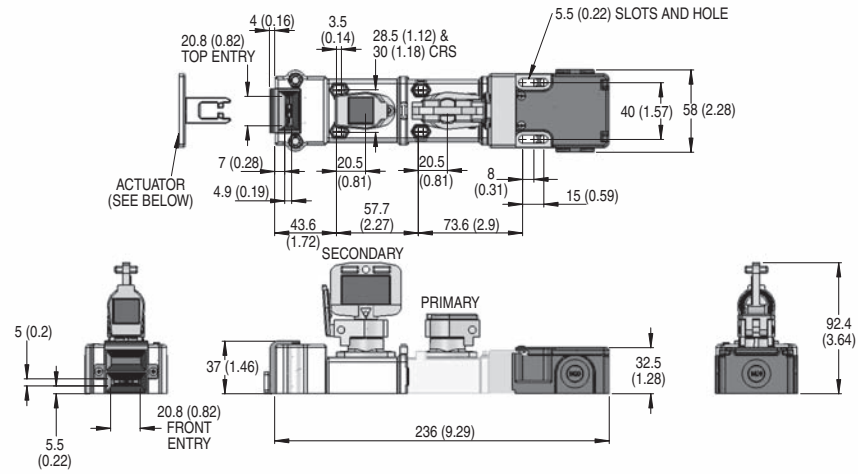







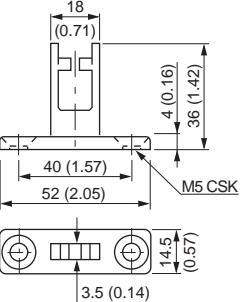

3-Trapped Key  
Switches

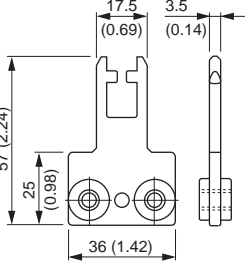

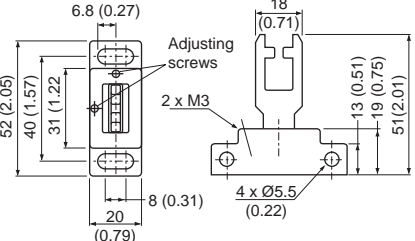
Safety Switches  
Slamlock Electrical

Accessories

	Description	Approximate Dimensions [mm (in.)]	Cat. No.
	GD2 standard actuator		440G-A27011
	GD2 flat actuator		440K-A11112
	Fully flex actuator		440G-A27143
	Stainless steel key		440T-AKEYE10⊗
	Stainless steel replacement code barrel with dust cap	page 3-140	440T-ASCBE14*
	Stainless steel weatherproof replacement dust cap		440T-ASFC10⊗

3-Trapped Key Switches

\* Substitute the desired primary code for this symbol (key not included). See 3-107 for code selection.  
 ⊗ Substitute the desired code for this symbol. See 3-107 for code selection.

Typical Applications

Actuator out, key trapped, safety contacts open, auxiliary contact closed.

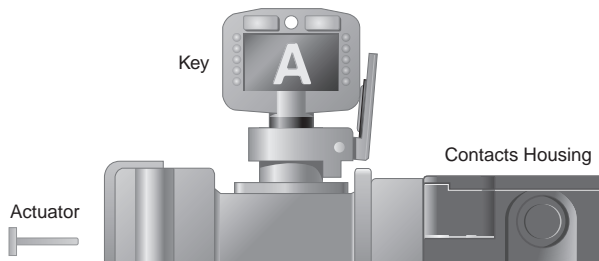

Locking force = 2000 N (450 lb)

## Safety Switches Miniature Valve Interlocks



### Features

- Direct drive operation
- Supplied with valves 0.25...1 in.
- Direct body mounting with security screws
- Locked open or locked closed options
- Virtually maintenance free
- Weatherproof stainless steel dust cap as standard
- Replaceable code barrel assembly
- Valve is chrome-plated brass

### Approximate Dimensions [mm (in.)]

Dimensions are not intended to be used for installation purposes.

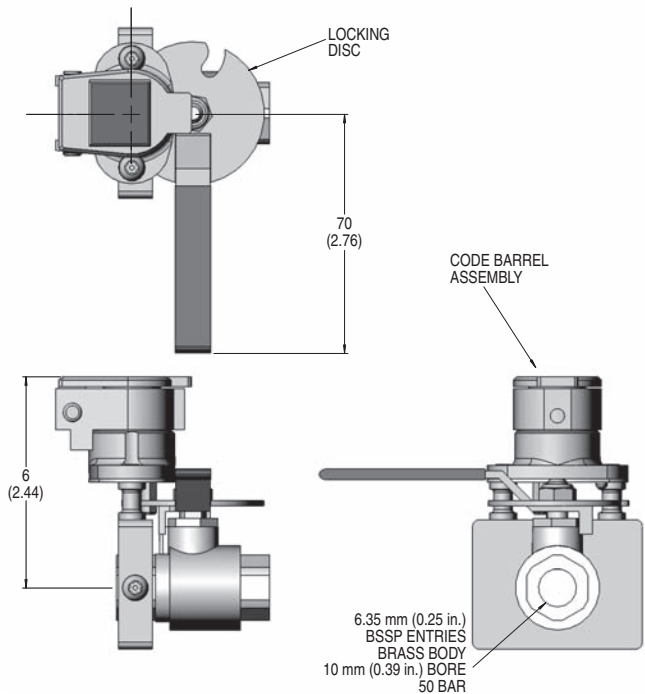

### Specifications

Standards	EN1088, ISO12100-1&2, ISO14119, AS4024.1
Certifications	CE Marked for all applicable directives and BG
Operating Temperature [C (F)]	-10...+40 ° (14...104 °)
Mechanical Life	100,000 operations
Shear Force to Key	15.1 k•N (3398 lbs)
Torque to Key	14 N•m (124 lb•in)
Relative Humidity	25...95%
Material	316L stainless steel

### Product Selection

Valve Size	Valve Status	Cat. No.
0.25 in. BSP*	Key Free/Valve Locked Closed	440T-VMVLE10*
0.375 in. BSP*		440T-VMVLE11*
0.5 in. BSP*		440T-VMVLE12*
0.25 in. BSP*	Key Free/Valve Locked Open	440T-VMVLE13*
0.375 in. BSP*		440T-VMVLE14*
0.5 in. BSP*		440T-VMVLE15*
1.0 in. BSP*	Key Free/Valve Locked Closed	440T-VMVLE18*
	Key Free/Valve Locked Open	440T-VMVLE19*
2.0 in. BSP*	Key Free/Valve Locked Closed	440T-VMVLE20*
	Key Free/Valve Locked Open	440T-VMVLE21*

\* Substitute the desired primary code for this symbol (key not included). See 3-107 for code selection.

\* BSP = British standard pipe threads.

### Accessories

Description	Additional Information	Cat. No.
Stainless steel key	3-140	440T-AKEYE10*
Stainless steel replacement code barrel with dust cap		440T-ASCBE14*
Stainless steel weatherproof replacement dust cap		440T-ASFC10*

\* Substitute the desired primary code for this symbol (key not included). See 3-107 for code selection.

### Approximate Dimensions [mm (in.)]

Model	A	B	C
440T-VMVLE10	104 (4.1)	68 (2.7)	38 (1.5)
440T-VMVLE11	104 (4.1)	68 (2.7)	38 (1.5)
440T-VMVLE12	112 (4.4)	80 (3.2)	48 (1.9)
440T-VMVLE13	104 (4.1)	68 (2.7)	38 (1.5)
440T-VMVLE14	104 (4.1)	68 (2.7)	38 (1.5)
440T-VMVLE15	112 (4.4)	80 (3.2)	48 (1.9)
440T-VMVLE16	108 (4.3)	110 (4.3)	53 (2.1)
440T-VMVLE17	108 (4.3)	110 (4.3)	53 (2.1)
440T-VMVLE18	115 (4.5)	110 (4.3)	61 (2.4)
440T-VMVLE19	115 (4.5)	110 (4.3)	61 (2.4)

## Safety Switches Switchgear Adaptors



### Description

The switch gear adaptor is used to interlock preparatory switch gear applications or other host equipment such as spool valves. Power is isolated and locked off when the key is rotated and removed. The key can then be used in the next sequence of operation.

### Features

- Virtually maintenance free

### Specifications

Standards	EN1088, ISO12100-1&2, ISO14119, AS4024.1
Category	Cat. 1 per EN 954-1
Certifications	CE Marked for all applicable directives and BG
Operating Temperature [C (F)]	-10...+50 ° (14...122 °)
Mechanical Life	>100,000 operations
Shear Force to Key	15.1 k•N (3398 lbs), max.
Torque to Key	14 N•m (124 lb•in), max.
Relative Humidity	95%
Weight [kg (lbs)]	0.30 (0.66)
Material	316L stainless steel
Mounting	2 x M4
Shaft Dimensions	3/8 in <sup>2</sup> x 7/8 in long (standard) 9/16 in dia. x 7/8 in long (optional: contact factory)

### Product Selection (3/8 square shaft)

Mounting	Trap Direction	Cat. No.
2 x M4	65° CW to trap	440T-MSGAU10*
	65° CCW to trap	440T-MSGAU11*
	90° CW to trap	440T-MSGAU12*
	90° CCW to trap	440T-MSGAU13*
	±90° to trap	440T-MSGAU14*
	45° CW to trap	440T-MSGAU17*
	45° CCW to trap	440T-MSGAU18*

\* Substitute the desired primary code for this symbol (key not included). See 3-107 for code selection.

### Accessories

Description	Additional Information	Cat. No.
Stainless steel key	3-140	440T-AKEYE10*
Stainless steel ejector key		440T-AKEYE13*
Stainless steel weatherproof replacement dust cap		440T-ASFC10*

\* Substitute the desired primary code for this symbol (key not included). See 3-107 for code selection.

### Approximate Dimensions [mm (in.)]

Dimensions are not intended to be used for installation purposes.

#### 45° Mounting Type

#### Panel Drilling Detail

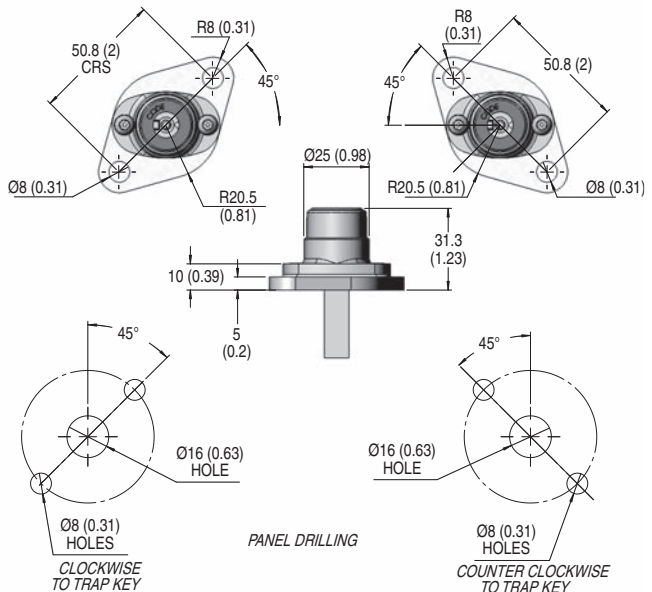

3-Trapped Key Switches









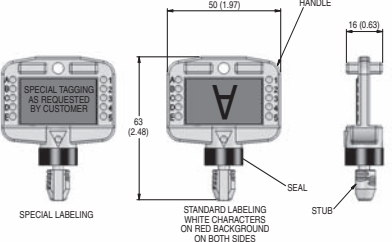

### The Prosafe Advantage

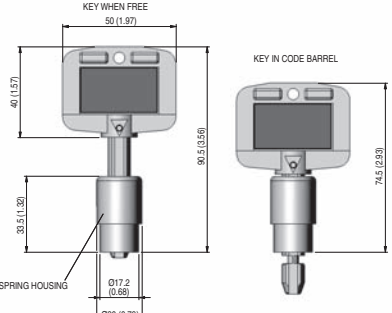

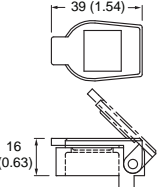
Stainless steel construction.

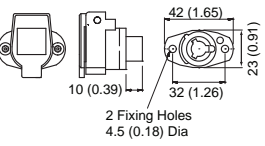
## Safety Switches Accessories

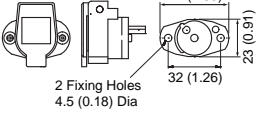
### Accessories

	Description	Approximate Dimensions [mm (in.)]	Cat. No.
	Stainless steel key		440T-AKEYE10*
	Stainless steel ejector key		440T-AKEYE13*
	Stainless steel weatherproof replacement dust cap		440T-ASFC10*
	Stainless steel replacement code barrel for 100 A unit rotary switch		440T-ASCBE11*
	Stainless steel replacement code barrel with dust cap*		440T-ASCBE14*
	<b>Description</b>	<b>Material</b>	<b>Cat. No.</b>
	Emergency break glass key box	Plastic case	440T-AIPB11
		Metal case with hammer	440T-AIPB12
	<b>Description</b>	<b>Code</b>	<b>Cat. No.</b>
	Emergency repair kit for code barrels* 2 offset pin code barrels with key	ER1	440T-AKITE45ER1
		ER2	440T-AKITE45ER2
		ER3	440T-AKITE45ER3
		ER4	440T-AKITE45ER4
		ER5	440T-AKITE45ER5
		ER6	440T-AKITE45ER6
		ER7	440T-AKITE45ER7
		ER8	440T-AKITE45ER8
		ER9	440T-AKITE45ER9

\* Substitute the desired primary code for this symbol (key not included). See 3-107 for code selection.

\* Not suitable for 440T-MRKSE14/440T-MRPSE14 OR 440T-MSGAU units.



**WARNING:** The presence of spare keys, override keys, or spare actuators can compromise the integrity of safety interlocking systems. Personal injury or death, property damage or economic loss can result from the introduction of spare keys, override keys or spare actuators into interlocking systems without appropriate management controls, working procedures and alternative protective measures to control their use and availability.

## Safety Switches IEC Style Switches Overview



22 mm Small Plastic



22 mm Compact Metal



30 mm Large Metal



15 mm Plastic

### General Description

The 440P limit switch family offers a full range of international-style solutions for both safety and standard sensing applications. Available in four different body styles—30 mm metal, 22 mm metal and plastic, and 15 mm plastic—with a broad selection of operator types, circuit arrangements and connection options, the 440P is ideal for a wide variety of applications. These include material handling, packaging, elevators, escalators, scissor lifts, industrial trucks and tractors, cranes and hoists, overhead door as well as general safety guarding applications.

### Mechanical Enclosure

The large metal-body (440P-M) models feature die-cast alloy construction and conform to EN 50041 (30 x 60 mm), while the small plastic (440P-C) models are constructed of a glass-filled polymer and conform to EN 50047 (22 mm). Both body types are IP66 rated and available with M20 or 1/2 in. NPT conduit opening or in a micro quick-disconnect version. The 15 mm plastic models (440P-M18001 and 440P-M18002) are constructed of glass-filled polyester and are IP30 rated. The 22 mm metal models (440P-A) have a painted body and are IP66/IP67 rated.

### Actuator Type

The 440P international-style limit switches are available with a wide variety of actuators to solve a broad range of applications. All lever-type switches include their respective actuator arm. The large, metal-body style is available in the following operator types:

- Metal roller plunger
- Metal dome plunger
- Metal short lever

The compact metal body style is available in the following operator types:

- Roller plunger
- Dome plunger
- Short lever
- Cross roller plunger

All, except the short lever, are available with panel mount threading.

The small, plastic-body style is available in the following operator types:

- Short lever
- Hinge lever
- Roller plunger
- Dome plunger
- Offset hinge lever

The 15 mm plastic switch is available with top push roller and top push cross roller actuators.

### Contact Arrangements

All 440P international-style limit switches contain positive opening-action contacts, making them ideal for safety-related applications. The small, plastic models include a choice of snap-acting, slow-break/make with 2- or 3-contact configurations, while the large-metal switches contain snap-acting, slow-break contacts in 2-, 3-, or 4-contact configurations. The 15 mm plastic versions are slow-break, 2-circuit models. The small metal models are all snap-acting, 2-circuit.

3-Limit  
Switches

## Safety Switches

### IEC Style Switches

#### 22 mm Compact Metal Position Switches



#### Description

The 22 mm IEC style metal safety limit switches have been developed to provide a small metal case with a choice of actuator heads. All units are supplied with an integral 2 m cable. For safety applications it is important that upon actuation, the guard or other moving objects should not pass completely over the switch and allow the plunger or lever to return to its original position.

#### Features

- Rugged die cast enclosure
- Positive operation, forced disconnection of contacts (direct opening action)
- Snap-acting contact actuation
- Contacts 1 N.C. + 1 N.O.
- Pre-wired 2 m cable, bottom or side exit

3-Limit  
Switches

#### Specifications

Safety Ratings						
Standards	EN 954-1, ISO 13849-1, IEC/EN 60204-1, NFPA 79, EN 1088, ISO 14119, IEC/EN 60947-5-1, ANSI B11.19, AS 4024.1					
Safety Classification	Cat. 1 Device per EN 954-1 Dual channel limit switch suitable for Cat. 3 or 4 systems when ganged together					
Certifications	UL Recognized, TÜV and CE Marked for all applicable directives					
Outputs						
Safety Contacts *	1 N.C. snap acting					
Auxiliary Contacts	1 N.O. snap acting					
Thermal Current	10 A					
Rated Insulation Voltage	300V AC					
Contact Rating						
Maximum AC Contact Rating Per Pole						
NEMA Rating	Max. Voltage	Amperes		Continuous Carrying Current (Amp.)	Volt Amperes	
		Make	Break		Make	Break
AC15/B300	120	30	3.0	5	3600	360
AC15/B300	240	15	1.5			
Maximum DC Contact Rating Per Pole						
DC13/Q300	240	0.27	0.27	2.5	69	69
Operating Characteristics						
Actuation Speed, Max.	250 mm/s					
Actuation Speed, Min.	100 mm/min					
Actuation Frequency, Max.	6000 operations per hr					
Mechanical Life	1 x 10 <sup>7</sup>					
Environmental						
Enclosure Type Rating	NEMA 1, IP66/67					
Operating Temperature [C (F)]	2...70 ° (35.6...158 °)					
Pollution Degree	3					
Physical Characteristics						
Housing Material	Die-cast alloy					
Actuator Material	Various polymers and metals					
Mounting	2 x M14, any position					
Vibration	IEC 68-2-6 (10...55 Hz, 0.35 mm amplitude)					
Shock	IEC 68-2-7 (30 Gn 3 pulses per axis)					
Connection Type	2 m (6.5 ft) cable					
Color	Red body/black head					

\* The safety contacts are described as normally closed (N.C.) i.e., with the guard closed, actuator in place (where relevant) and the machine able to be started.

## Safety Switches IEC Style Switches 22 mm Compact Metal Position Switches

### Product Selection

Operator Type	Contact			Typical Force/Torque to Operate	Panel Mount	Contact Opening Characteristics	Cat. No.	
	Safety	Auxiliary	Type				Bottom Cable Style	Side Cable Style
Roller Plunger	1 N.C.	1 N.O.	Snap Acting	10 (2.25)	No		440P-ARPS11C	440P-ARPS11CS
					Yes		440P-ARP1S11C	440P-ARP1S11CS
Dome Plunger	1 N.C.	1 N.O.	Snap Acting	10 (2.25)	No		440P-ADPS11C	440P-ADPS11CS
					Yes		440P-ADP1S11C	440P-ADP1S11CS
Cross Roller Plunger	1 N.C.	1 N.O.	Snap Acting	10 (2.25)	No	440P-ACRS11C	440P-ACRS11CS	
					Yes	440P-ACR1S11C	440P-ACR1S11CS	
Lever	1 N.C.	1 N.O.	Snap Acting	0.7 N•m (0.62 lb•in)	—		440P-ASLS11C	440P-ASLS11CS

### Approximate Dimensions [mm (in.)]

Dimensions are not intended to be used for installation purposes.

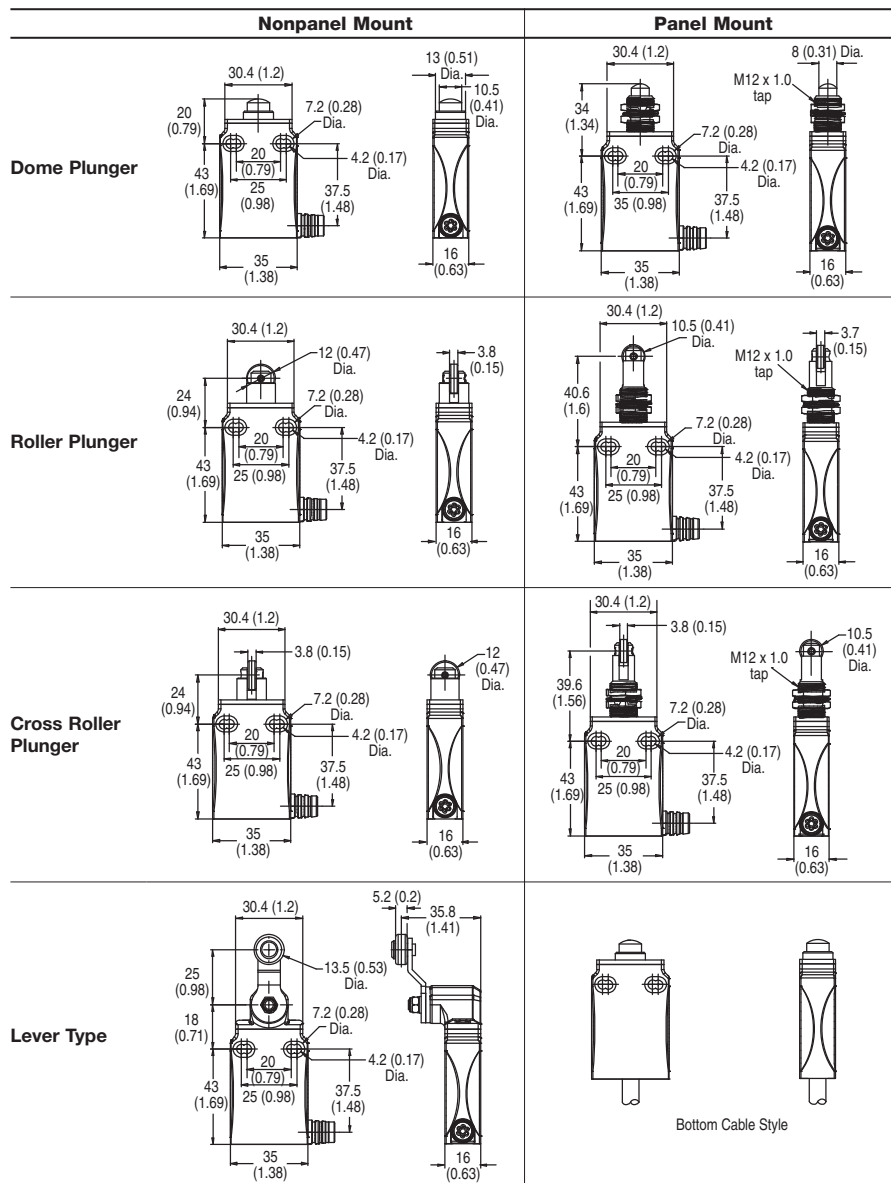

- Side cable style shows strain relief only. Units include a 2 m integral cable.
- Bottom cable style units have same dimensions as side cable style.
- Panel mount clearance hole = 13 mm (0.51 in.)

### Countersink Hole

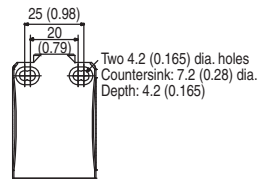

### Typical Wiring Diagrams

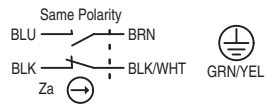

3-Limit Switches

## Safety Switches

### IEC Style Switches

#### 22 mm Plastic Body



#### Description

These 22 mm plastic-body safety limit switches conform to EN 50047 standards and are available with snap-acting or slow-break/make 2- or 3-contact configurations as well as a variety of actuator heads.

These switches also feature an optional rotating head that can be adjusted in 90° increments before installation to allow for ease of mounting.

Allen-Bradley Guardmaster limit switches can be used in guard door applications as well as on moving machine beds, crane arms, lifts, elevators, etc.

Operation of these limit switches is achieved by the sliding action of a guard, or other moving object, deflecting the plunger or lever. For safety applications, it is important that upon actuation, the guard or moving object should not pass completely beyond the switch to allow the plunger or lever to return to its original position—the plunger or lever must remain engaged by the guard or object.

#### Features

- Large selection of actuator heads
- Positive operation, forced disconnection of contacts
- Snap-acting, slow make before break or slow break before make contact blocks
- Contacts 1 N.C. + 1 N.O., 2 N.C. + 1 N.O. 3 N.C.
- Conforms to EN 50047, EN 1088, EN 60947-5-1, EN 292 and EN 60204-1

#### Operating Examples

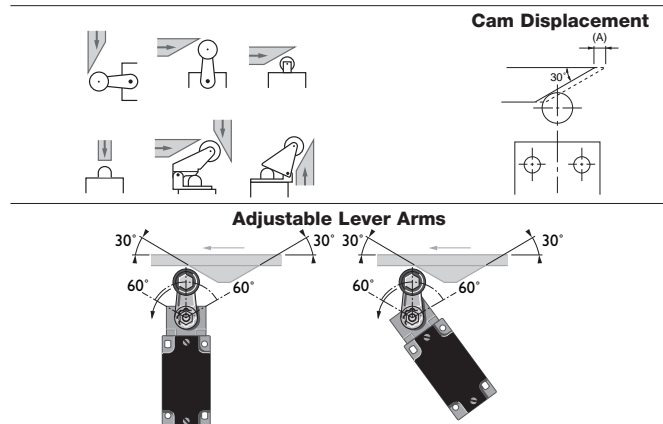

The actuating cam should be profiled at 30° for optimum operation.

**Note:** Plunger-type switches operate from a flat profile.

#### Specifications

Safety Ratings	
Standards	EN 954-1, ISO 13849-1, IEC/EN 60204-1, NFPA 79, EN 1088, ISO 14119, IEC/EN 60947-5-1, ANSI B11.19, AS 4024.1
Safety Classification	Cat. 1 Device per EN 954-1 Dual channel limit switch suitable for Cat. 3 or 4 systems and used with a safety monitoring device
Functional Safety Data *	B10d: > 2 x 10 <sup>6</sup> operations at min. load PFH <sub>D</sub> : > 3 x 10 <sup>-7</sup> MTTF <sub>D</sub> : > 385 years Dual channel limit switch may be suitable for performance levels Pl <sub>e</sub> or Pl <sub>d</sub> (according to ISO 13849-1:2006) and for use in SIL2 or SIL3 systems (according to IEC 62061) depending on application characteristics
Certifications	CE Marked for all applicable directives, cULus, and TÜV
Outputs	
Safety Contacts *	1 N.C. snap acting, 2 N.C. or 3 N.C. slow acting
Auxiliary Contacts	1 N.O. (except 3 N.C. versions)
Thermal Current I <sub>th</sub>	10 A
Rated Insulation Voltage	600V AC
Switching Current @ Voltage, Min.	25 mA @ 5V DC
Utilization Category	
A600/AC-15	(U <sub>e</sub> ) 600V 500V 240V 120V (I <sub>e</sub> ) 1.2 A 1.4 A 3.0 A 6.0 A
N600/DC-13	(U <sub>e</sub> ) 600V 500V 250V 125V (I <sub>e</sub> ) 0.4 A 0.55 A 1.1 A 2.2 A
Operating Characteristics	
Actuation Speed, Max.	250 mm/s
Actuation Speed, Min.	100 mm/min
Actuation Frequency, Max.	6000 operation per hour
Mechanical Life	1 x 10 <sup>7</sup>
Environmental	
Enclosure Type Rating	IP66
Operating Temperature [C (F)]	-25...80° (-18...+176°)
Pollution Degree	3
Physical Characteristics	
Housing Material	UL Approved glass-filled polybutylene terephthalate
Actuator Material	Various polymers and metals
Mounting	2 x M4, Any position
Vibration	IEC 68-2-6 (10...55 Hz, 0.35 mm amplitude)
Shock	IEC 68-2-7 (30 Gn 3 pulses per axis)
Conduit Entry	M20 or 1/2 inch NPT
Color	Red

\* Usable for ISO 13849-1:2006 and IEC 62061. Data other than B10d is based on:





- Usage rate of 1op/10 mins., 24 hrs/day, 360 days/year, representing 51840 operations per year
- Mission time/Proof test interval of 38 years

\* The safety contacts are described as normally closed (N.C.) i.e., with the guard closed, actuator in place (where relevant) and the machine able to be started.

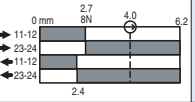
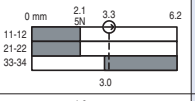
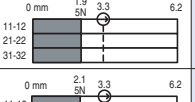
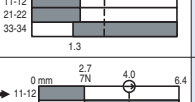

## Safety Switches IEC Style Switches 22 mm Plastic Body

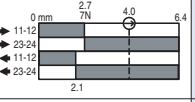
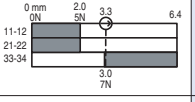
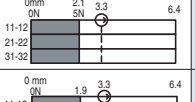
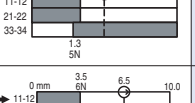
### Product Selection

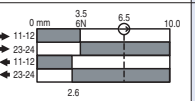
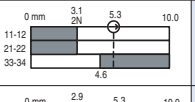
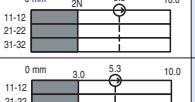
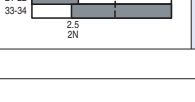



Description	Contact			Typical Force/Torque to Operate	Contact Opening Characteristics □ Open ■ Closed ⊕ Positive Opening Point	Cat. No.		
	Safety	Auxiliary	Type			1/2 inch NPT Conduit	M20 Conduit	Connector Style*
	1 N.C.	1 N.O.	Snap acting	5 N		<b>440P-CRPS11E</b>	440P-CRPS11B	440P-CRPS11D4
	2 N.C.	1 N.O.	BBM	6 N		440P-CRPB12E	440P-CRPB12B	440P-CRPB12R6
	3 N.C.	—	—	5 N		440P-CRPB03E	440P-CRPB03B	440P-CRPB03R6
Roller Plunger	2 N.C.	1 N.O.	MBB	6 N		440P-CRPM12E	440P-CRPM12B	440P-CRPM12R6
	1 N.C.	1 N.O.	Snap acting	5N		<b>440P-CDPS11E</b>	440P-CDPS11B	440P-CDPS11D4
	2 N.C.	1 N.O.	BBM	6N		440P-CDPB12E	440P-CDPB12B	440P-CDPB12R6
	3 N.C.	—	—	5N		440P-CDPB03E	440P-CDPB03B	440P-CDPB03R6
Dome Plunger	2 N.C.	1 N.O.	MBB	6N		440P-CDPM12E	440P-CDPM12B	440P-CDPM12R6
	1 N.C.	1 N.O.	Snap Acting	5N		<b>440P-CHLS11E</b>	440P-CHLS11B	440P-CHLS11D4
	2 N.C.	1 N.O.	BBM	6N		<b>440P-CHLB12E</b>	440P-CHLB12B	440P-CHLB12R6
	3 N.C.	—	—	5N		440P-CHLB03E	440P-CHLB03B	440P-CHLB03R6
	Hinge Lever	2 N.C.	1 N.O.	MBB	6N		440P-CHLM12E	440P-CHLM12B
Recommended standard cordset, 2 m, 4-pin, DC Micro (M12) connector.								889D-F4AC-2
Recommended standard cordset, 2 m, 6-pin, AC Micro (M12) connector.								889R-F6ECA-2

3-Limit  
Switches

\* D4 suffix uses a 4-pin DC Micro (M12) connector and R6 suffix uses a 6-pin AC Micro (dual keyway) consumer.

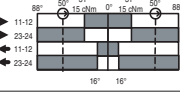
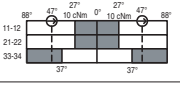
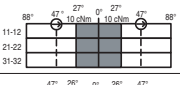
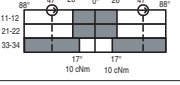
## Safety Switches IEC Style Switches 22 mm Plastic Body

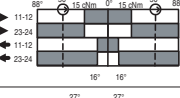
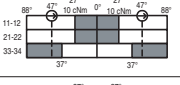
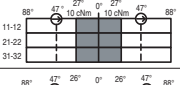
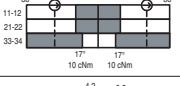
### Product Selection (continued)

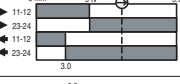
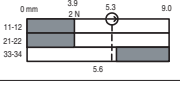
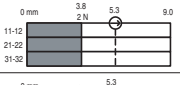
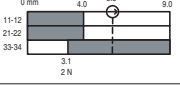
Description	Contact			Typical Force/Torque to Operate	Contact Opening Characteristics □ Open ■ Closed ⊕ Positive Opening Point	Cat. No.		
	Safety	Auxiliary	Type			1/2 inch NPT Conduit	M20 Conduit	Connector Style*
	1 N.C.	1 N.O.	Snap acting	0.15 N•m		440P-CSLS11E	440P-CSLS11B	440P-CSLS11D4
	2 N.C.	1 N.O.	BBM	0.14 N•m		440P-CSLB12E	440P-CSLB12B	440P-CSLB12R6
	3 N.C.	—	—	0.14 N•m		440P-CSLB03E	440P-CSLB03B	440P-CSLB03R6
	2 N.C.	1 N.O.	MBB	0.14 N•m		440P-CSLM12E	440P-CSLM12B	440P-CSLM12R6
	1 N.C.	1 N.O.	Snap acting	0.15 N•m		440P-CMHS11E	440P-CMHS11B	440P-CMHS11D4
	2 N.C.	1 N.O.	BBM	0.14 N•m		440P-CMHB12E	440P-CMHB12B	440P-CMHB12R6
	3 N.C.	—	—	0.14 N•m		440P-CMHB03E	440P-CMHB03B	440P-CMHB03R6
	2 N.C.	1 N.O.	MBB	0.14 N•m		440P-CMHM12E	440P-CMHM12B	440P-CMHM12R6
	1 N.C.	1 N.O.	Snap acting	5 N		440P-COHS11E	440P-COHS11B	440P-COHS11D4
	2 N.C.	1 N.O.	BBM	6 N		440P-COHB12E	440P-COHB12B	440P-COHB12R6
	3 N.C.	—	—	5 N		440P-COHB03E	440P-COHB03B	440P-COHB03R6
	2 N.C.	1 N.O.	MBB	6 N		440P-COHM12E	440P-COHM12B	440P-COHM12R6
Recommended standard cordset, 2 m, 4-pin, DC Micro (M12) connector.								889D-F4AC-2
Recommended standard cordset, 2 m, 6-pin, AC Micro (M12) connector.								889R-F6ACA-2

\* D4 suffix uses a 4-pin DC Micro (M12) connector and R6 suffix uses a 6-pin AC Micro (dual keyway) connector.

3-Limit Switches

Safety Switches  
**IEC Style Switches**  
 22 mm Plastic Body

Typical Wiring Diagrams \*

Two-Circuit Type D4 4-Pin Micro Connector

Connector Pinout		1 N.C. + 1 N.O.	
		Terminal	Contact
<p>1 N.O. + 1 N.C.</p>		1	11
		3	12
		2	23
		4	24
			N.C.
			N.O.

Three-Circuit Type R6 6-Pin Micro Connector

Connector Pinout		3 N.C.		2 N.C. + 1 N.O.		
		Terminal	Contact	Terminal	Contact	
<p>3 N.C.      2 N.C. + 1 N.O.</p>		1	11			
		5	12	N.C.	12	N.C.
		2	21	N.C.	21	N.C.
		6	22	N.C.	22	N.C.
		3	33	N.O.	31	N.C.
		4	34		32	

\* See page 3-145 for positive opening circuits.

Approximate Dimensions [mm (in.)]

Dimensions are not intended to be used for installation purposes.

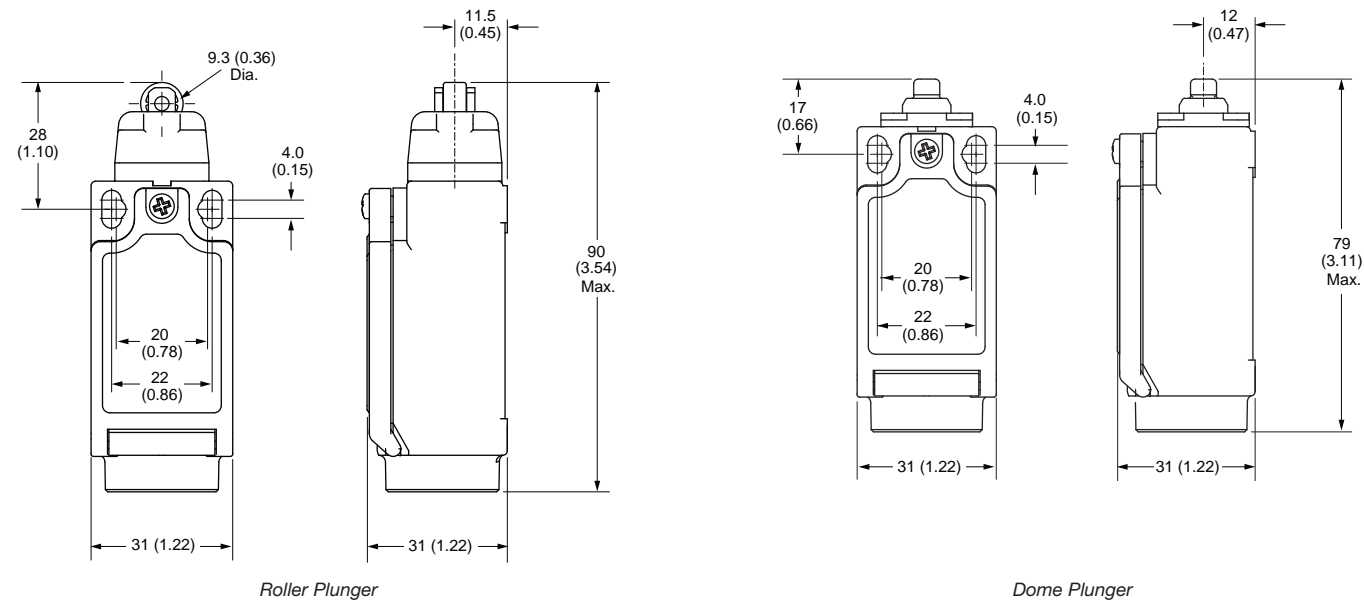

3-Limit  
Switches

## Safety Switches

### IEC Style Switches

#### 22 mm Plastic Body

#### Approximate Dimensions [mm (in.)] (continued)

Dimensions are not intended to be used for installation purposes.

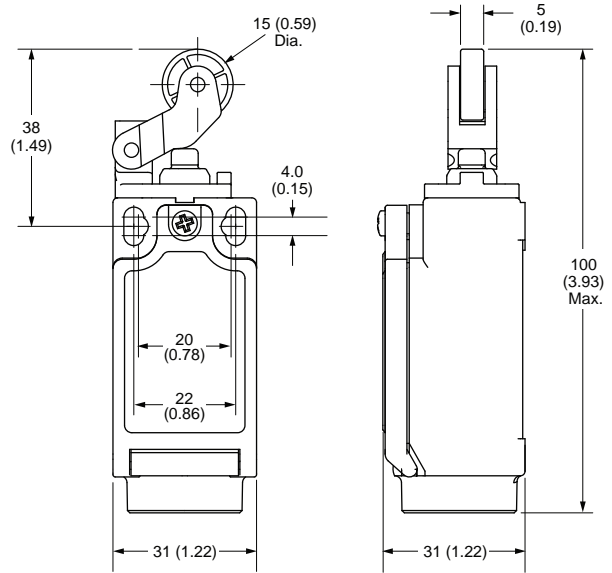

Hinge Lever

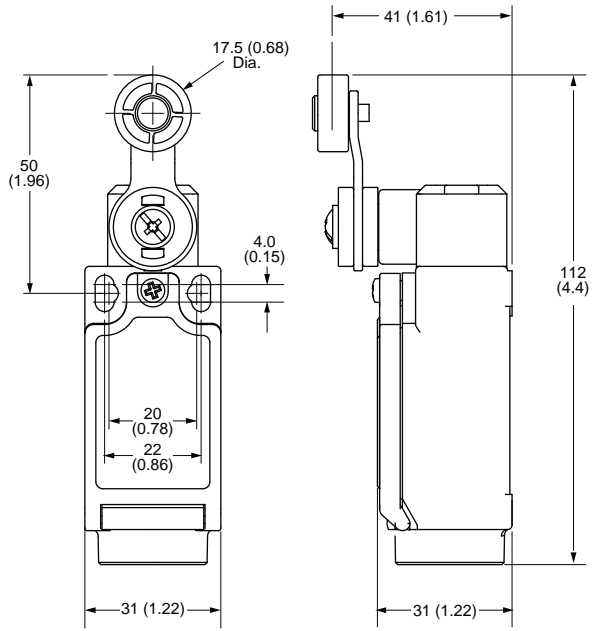

Short Lever,  
Metal and Plastic Roller

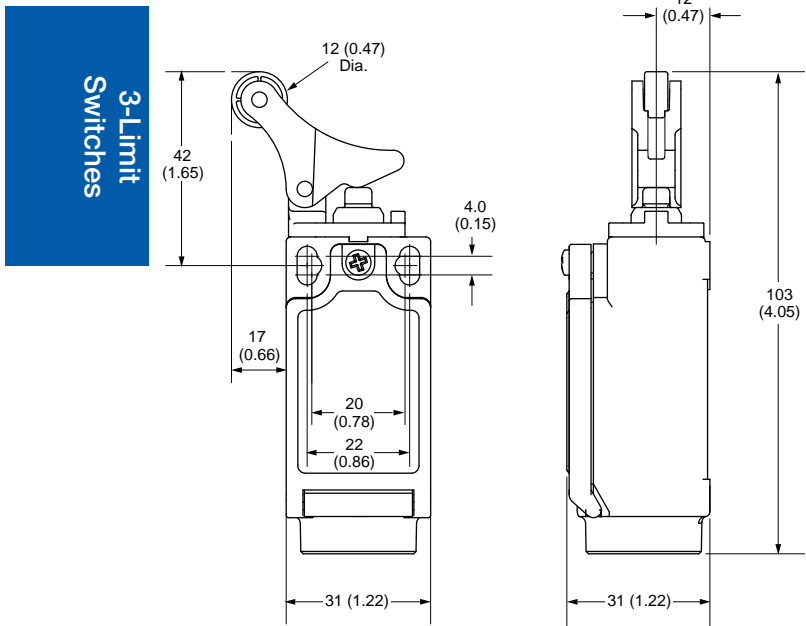

Offset Hinge

3-Limit  
Switches

## Safety Switches

# IEC Style Switches

### 30 mm Metal Body



### Description

These 30 mm metal-body safety limit switches conform to EN 50041 standards and are available in snap acting or slow break/make with 2-, 3- or 4-contact configurations.

These switches feature a rotating head that can be adjusted in 90° increments before installation to allow for ease of mounting.

Allen-Bradley Guardmaster can be used in guard door applications as well as on moving machine beds, crane arms, lifts, elevators, etc.

Operation of these limit switches is achieved by the sliding action of a guard, or other moving object, deflecting the plunger or lever. For safety applications, it is important that upon actuation, the guard or moving object should not pass completely beyond the switch to allow the plunger or lever to return to its original position—the plunger or lever must remain engaged by the guard or object.

### Features

- Large selection of actuator heads
- Positive operation, forced disconnection of contacts
- Snap-acting, slow make before break or slow break before make contact blocks
- Contacts 1 N.C. + 1 N.O., 2 N.C. + 2 N.O., 3 N.C. + 1 N.O., or 4 N.C.
- Conforms to EN 50041, EN 1088, EN 60947-5-1, EN 292 and EN 60204-1

### Operating Examples

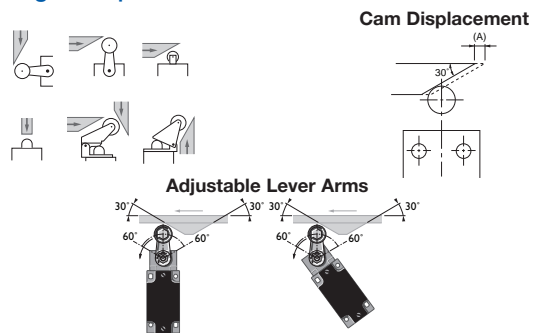

For optimum cam operation, the actuating arm should be adjusted with a 30° offset profile.

**Note:** Plunger-type switches operate from a flat profile.

### Specifications

Safety Ratings	
Standards	EN 954-1, ISO 13849-1, IEC/EN 60204-1, NFPA 79, EN 1088, ISO 14119, IEC/EN 60947-5-1, ANSI B11.19, AS 4024.1
Safety Classification	Cat. 1 Device per EN954-1 Dual-channel limit switch suitable for Cat. 3 or 4 systems and used with a safety monitoring device
Functional Safety Data *	B10d: > 2 x 10 <sup>6</sup> operations at min. load PFH <sub>D</sub> : > 3 x 10 <sup>-7</sup> MTTF <sub>D</sub> : > 385 years Dual channel limit switch may be suitable for performance levels Ple or Pld (according to ISO 13849-1:2006) and for use in SIL2 or SIL3 systems (according to IEC 62061) depending on application characteristics
Certifications	CE Marked for all applicable directives, cULus, and TÜV
Outputs	
Safety Contacts *	1 N.C. snap acting, 2 N.C., 3 N.C. or 4 N.C. slow acting
Auxiliary Contacts	1 N.O., 2 N.O., or zero
Thermal Current <sub>th</sub>	10 A
Rated Insulation Voltage	600V AC
Switching Current @ Voltage, Min.	25 mA @ 5V DC
Utilization Category	
A600/AC-15	(Ue) 600V 500V 240V 120V (Ie) 1.2 A 1.4 A 3.0 A 6.0 A
N600/DC-13	(Ue) 600V 500V 250V 125V (Ie) 0.4 A 0.55 A 1.1 A 2.2 A
Operating Characteristics	
Actuation Speed, Max.	250 mm/s
Actuation Speed, Min.	100 mm/min
Actuation Frequency, Max.	6000 operation per hour
Mechanical Life	1 x 10 <sup>7</sup>
Environmental	
Enclosure Type Rating	IP66
Operating Temperature [C (F)]	-25...80° (-18...+176°)
Pollution Degree	3
Physical Characteristics	
Housing Material	Die-cast alloy
Actuator Material	Various polymers and metals
Mounting	2 x M5, Any position
Vibration	IEC 68-2-6 (10...55 Hz, 0.35 amplitude)
Shock	IEC 68-2-7 (30 Gn 3 pulses per axis)
Conduit Entry	M20 or 1/2 inch NPT
Color	Red

\* Usable for ISO 13849-1:2006 and IEC 62061. Data other than B10d is based on:





- Usage rate of 1op/10 mins., 24 hrs/day, 360 days/year, representing 51840 operations per year
- Mission time/Proof test interval of 38 years

\* The safety contacts are described as normally closed (N.C.) i.e., with the guard closed, actuator in place (where relevant) and the machine able to be started.

3-Limit Switches

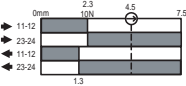
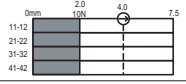
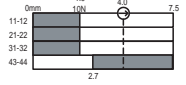
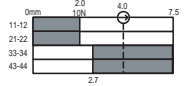
## Safety Switches IEC Style Switches 30 mm Metal Body

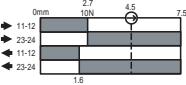
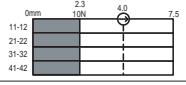
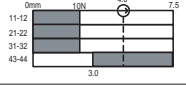
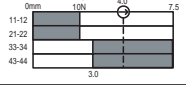
### Product Selection

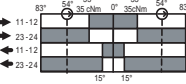
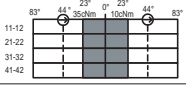
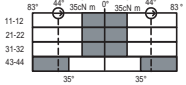
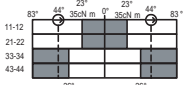
Description	Contact			Typical Force/Torque to Operate	Contact Opening Characteristics □ Open ■ Closed ⊕ Positive Opening Point	Cat. No.		
	Safety	Auxiliary	Type			1/2 inch NPT Conduit	M20 Conduit	Connector *
	1 N.C.	1 N.O.	Snap Acting	13 N		440P-MRPS11E	440P-MRPS11B	440P-MRPS11N5
	4 N.C.	—	—	11 N		440P-MRPB04E	440P-MRPB04B	440P-MRPB04M9
	3 N.C.	1 N.O.	BBM	11 N		440P-MRPB13E	440P-MRPB13B	440P-MRPB13M9
	2 N.C.	2 N.O.	BBM	11 N		<b>440P-MRPB22E</b>	440P-MRPB22B	440P-MRPB22M9
	1 N.C.	1 N.O.	Snap Acting	13 N		<b>440P-MDPS11E</b>	440P-MDPS11B	440P-MDPS11N5
	4 N.C.	—	—	11 N		440P-MDPB04E	440P-MDPB04B	440P-MDPB04M9
	3 N.C.	1 N.O.	BBM	11 N		440P-MDPB13E	440P-MDPB13B	440P-MDPB13M9
	2 N.C.	2 N.O.	BBM	11 N		440P-MDPB22E	440P-MDPB22B	440P-MDPB22M9
	1 N.C.	1 N.O.	Snap Acting	0.34 N•m		<b>440P-MSLS11E</b>	440P-MSLS11B	440P-MSLS11N5
	4 N.C.	—	—	0.20 N•m		440P-MSLB04E	440P-MSLB04B	440P-MSLB04M9
	3 N.C.	1 N.O.	BBM	0.34 N•m		440P-MSLB13E	440P-MSLB13B	440P-MSLB13M9
	2 N.C.	2 N.O.	BBM	0.34 N•m		440P-MSLB22E	440P-MSLB22B	440P-MSLB22M9
Recommended standard cordset, 2 m, 5-pin mini connector.								889N-F5AE-6F
Recommended standard cordset, 2 m, 12-pin 9-wire.								889M-FX9AE-2

\* N5 = 5-pin mini connector.  
M9 = 12-pin M23 connector (use 9 wire).

3-Limit  
Switches

## Safety Switches IEC Style Switches 30 mm Metal Body

### Product Selection (continued)

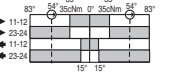
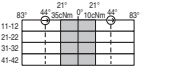
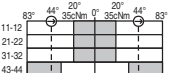
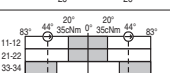
Description	Safety Contacts	Auxiliary Contacts	Contact Type	Typical Force/Torque to Operate	Contact Opening Characteristics	Cat. No.		
					<input type="checkbox"/> Open <input checked="" type="checkbox"/> Closed ⊕ Positive Opening Point	1/2 inch NPT Conduit	M20 Conduit	Connector *
	1 N.C.	1 N.O.	Snap Acting	0.34 N•m		440P-MMHS11E	440P-MMHS11B	440P-MMHS11N5
	4 N.C.	—	—	0.20 N•m		440P-MMHB04E	440P-MMHB04B	440P-MMHB04M9
	3 N.C.	1 N.O.	BBM	0.34 N•m		440P-MMHB13E	440P-MMHB13B	440P-MMHB13M9
	2 N.C.	2 N.O.	BBM	0.34 N•m		440P-MMHB22E	440P-MMHB22B	440P-MMHB22M9
Recommended standard cordset, 2 m, 5-pin mini connector.								889N-F5AE-6F
Recommended standard cordset, 2 m, 12-pin 9-wire.								889M-FX9AE-2

\* N5 = 5-pin mini connector.  
M9 = 12-pin M23 connector (use 9 wire).

### Typical Wiring Diagrams

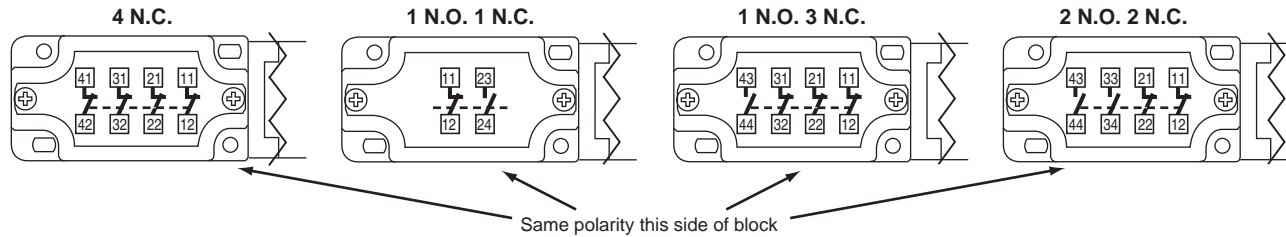

N5 Connector 2 Circuit 5-Pin Mini Connector

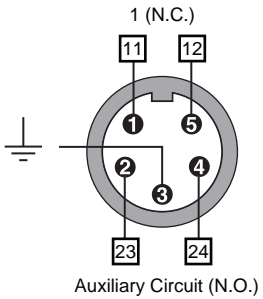

M9 12-Pin M23 Connector

Connector Pinout	4 N.C.		3 N.C. 1 N.O.		3 N.C.	
	Terminal	Contact	Terminal	Contact	Terminal	Contact
1	11	N.C.	11	N.C.	11	N.C.
3	12	N.C.	12	N.C.	12	N.C.
4	21	N.C.	21	N.C.	21	N.C.
6	22	N.C.	22	N.C.	22	N.C.
7	31	N.C.	31	N.C.	33	N.O.
8	32	N.C.	32	N.C.	34	N.O.
9	41	N.C.	43	N.O.	43	N.O.
10	42	N.C.	44	N.O.	44	N.O.
12	Ground					

## Safety Switches

### IEC Style Switches

#### 30 mm Metal Body

#### Approximate Dimensions [mm (in.)]

Dimensions are not intended to be used for installation purposes.

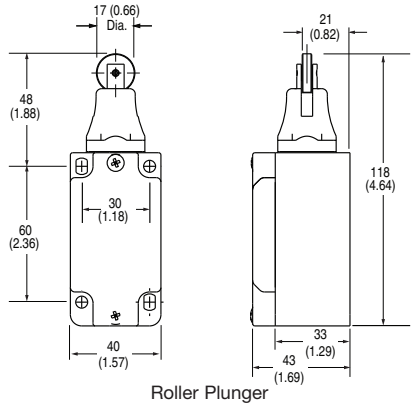

Roller Plunger

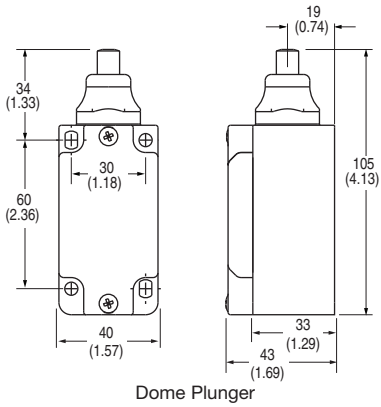

Dome Plunger

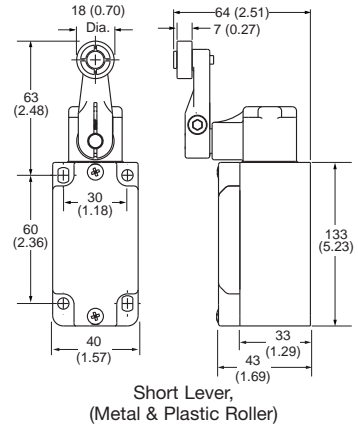

Short Lever,  
(Metal & Plastic Roller)





## Safety Switches IEC Style Switches 15 mm Plastic Body

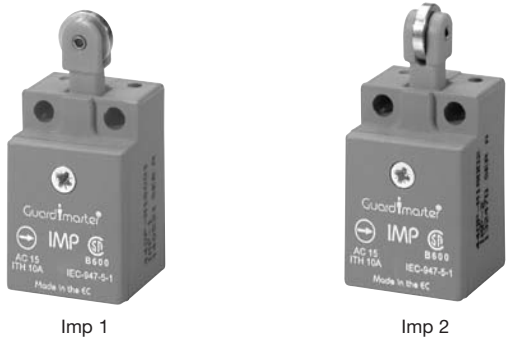

### Description

The Imp offers safety switch performance of bigger units in the most compact case available. Designed with two mounting hole options and a choice of actuator positions, the Imp will fit in most confined spaces.

### Features

- Positive operation, forced disconnection of contacts
- Contacts 1 N.C. + 1 N.O.

### Specifications

Safety Ratings	
Standards	EN 954-1, ISO 13849-1, IEC/EN 60204-1, NFPA 79, EN 1088, ISO 14119, IEC/ EN 60947-5-1, ANSI B11.19, AS 4024.1
Safety Classification	Cat. 1 Device per EN954-1 Dual channel limit switch suitable for Cat. 3 or 4 systems
Functional Safety Data *	B10d: > 2 x 10 <sup>6</sup> operations at min. load PFH <sub>D</sub> : > 3 x 10 <sup>-7</sup> MTTF <sub>D</sub> : > 385 years Dual channel limit switch may be suitable for performance levels Plc or Pld (according to ISO 13849-1:2006) and for use in SIL2 or SIL3 systems (according to IEC 62061) depending on application characteristics
<b>Note:</b> For up-to-date information, visit <a href="http://www.ab.com/Safety/">http://www.ab.com/Safety/</a>	
Certifications	CE Marked for all applicable directives and CSA NRTL/C
Outputs	
Safety Contacts *	1 N.C. positive break
Auxiliary Contacts	1 N.O.
Thermal Current/ <i>I<sub>th</sub></i>	10 A ( <i>I<sub>th</sub></i> )
Rated Insulation Voltage	(U <sub>i</sub> ) 500V
Switching Current @ Voltage, Min.	25 mA @ 5V DC
Utilization Category	
AC-15	(Ue) 500V 250V 100V
	(Ie) 1 A 2 A 5 A
DC	(Ue) 250V 24V
	(Ie) 0.5 A 2 A
Operating Characteristics	
Actuation Speed, Max.	160 mm (6.29 in.)/s
Actuation Speed, Min.	100 mm (3.93 in.)/min
Actuator Travel, Max.	5 mm (0.20 in.)
Actuation Frequency, Max.	2 cycles/s
Mechanical Life	10,000,000 operations
Electrical Life	1,000,000 operations
Mechanical Life	10,000,000 operations
Environmental	
Enclosure Type Rating	IP30
Operating Temperature [C (F)]	-25...80° (-13...176°)
Pollution Degree	3
Physical Characteristics	
Housing Material	UL Approved glass-filled PBT
Actuator Material	Stainless steel
Mounting	2 x M4 front or 2 x M3 top
Vibration	10...55 Hz
Shock	11 ms @ 30 g
Conduit Entry	3x break-outs
Color	Red

\* Usable for ISO 13849-1:2006 and IEC 62061. Data other than B10d is based on:

- Usage rate of 1op/10 mins., 24 hrs/day, 360 days/year, representing 51840 operations per year
- Mission time/Proof test interval of 38 years

\* The safety contacts are described as normally closed (N.C.) i.e., with the guard closed, actuator in place (where relevant) and the machine able to be started.

3-Limit  
Switches

# Safety Switches

## IEC Style Switches

### 15 mm Plastic Body

#### Product Selection

Actuator Type	Contact		Contact Action	Conduit	Type	Cat. No.
			<input type="checkbox"/> Open <input checked="" type="checkbox"/> Closed ⊕ Positive Opening Point			
Top push roller	Slow break before make	1 N.C. & 1 N.O.		3 x breakouts	Imp 1 (roller parallel to switch front)	440P-M18001
Top push cross roller					Imp 2 (roller perpendicular to switch front)	440P-M18002

#### Approximate Dimensions [mm (in.)]

Dimensions are not intended to be used for installation purposes.

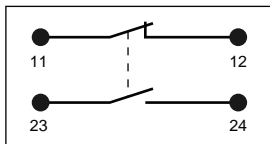
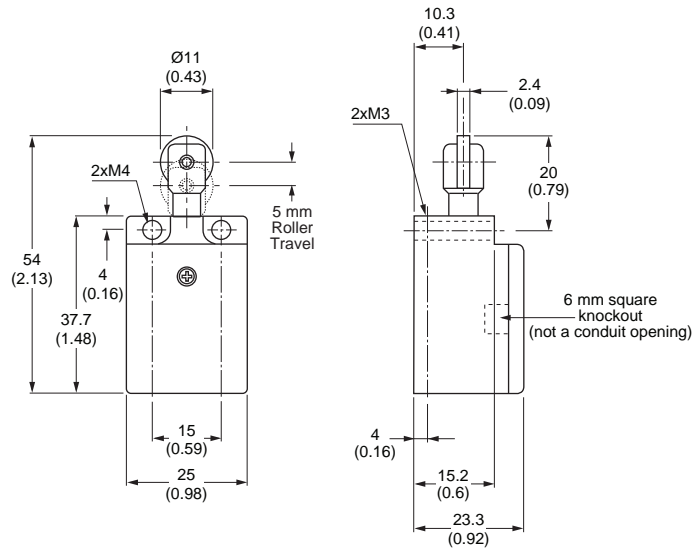

Wiring Diagrams

## Safety Switches

### NEMA Style Switches

#### 802T Direct Opening Action



#### Description

The 802T Direct Opening Action limit switches have been designed for use in control reliable applications and safety applications per ISO 14119. These limit switches utilize the same mounting dimensions as other NEMA style limit switches. The rugged metal construction and plug-in body are designed for use in harsh industrial environments.

Direct Opening Action allows the normally closed contacts to open when the limit switch is actuated. This opening will occur even in the event of a contact weld condition, up to 10 Newtons.



**ATTENTION:** To ensure that the normally closed (safety) contacts open, the limit switch actuator must be displaced beyond the point of Direct Opening Action (see specifications).

#### Features

- Direct opening action
- Snap acting contacts
- Rugged metal construction
- Long life and reliability
- Plug-in design
- NEMA 12, 13, 4, 6P/IP67 sealing

#### Typical Applications

- Machine guards
- Access gates and doors
- Cranes or hoists
- Transfer stations
- Indexing tables
- Robotic cells

#### Specifications

Safety Ratings	
Standards	EN 954-1, ISO 13849-1, IEC/EN 60204-1, NFPA 79, EN 1088, ISO 14119, IEC/EN 60947-5-1, ANSI B11.19, AS 4024.1
Safety Classification	Cat. 1 Device per EN 954-1 Dual channel limit switch suitable for Cat. 3 or 4 systems
Functional Safety Data *	B10d = > 2 x 10 <sup>6</sup> operations at min. load PFH <sub>D</sub> = > 3 x 10 <sup>-7</sup> MTTFd = > 385 years Dual channel limit switch may be suitable for Performance levels Pl <sub>e</sub> or Pl <sub>d</sub> (according to ISO 13849-1:2006) and for use in SIL2 or SIL3 systems (according to IEC 62061) depending on application characteristics
Certifications	CE Marked for all applicable directives, cULus Listed, and TÜV for 2- and 4-circuit models
Outputs	
Safety Contacts *	1 N.C. snap acting or 2 N.C. snap acting
Auxiliary Contacts	1 N.O. snap acting or 2 N.O. snap acting
Thermal Current/I <sub>th</sub>	10 A
Rated Insulation Voltage	300V AC or 600V AC
Switching Current @ Voltage, Min.	—
Utilization Category	
A600/AC-15	(Ue) 600V 500V 240V 120V (Ie) 1.2 A 1.4 A 3.0 A 6.0 A
N600/DC-13	(Ue) 600V 500V 250V 125V (Ie) 0.4 A 0.55 A 1.1 A 2.2 A
Operating Characteristics	
Actuation Speed, Max.	200 ft/min varies with applied loading and actuation method*
Actuation Speed, Min.	200 ft/min varies with applied loading and actuation method*
Actuation Frequency, Max.	8000 operations per hour
Mechanical Life	20 million cycles
Environmental	
Enclosure Type Rating	NEMA 4, 6P, 12, 13 and IP65/67
Operating Temperature [C (F)]	-18...+110° (0...+230°)
Pollution Degree	3
Physical Characteristics	
Housing Material	Die-cast alloy
Actuator Material	Various metals or plastics
Mounting	2 #10 equal length fasteners
Vibration	Contact fragility (10...2000 Hz @ 0.06 inch peak-to-peak)
Shock	Contact fragility (25 Gn 3 pulses per axis)
Conduit Entry	1/2 inch NPT or M20
Color	Grey

\* Usable for ISO 13849-1:2006 and IEC 62061. Data other than B10d is based on:

- Usage rate of 1op/10 mins., 24 hrs/day, 360 days/year, representing 51840 operations per year
- Mission time/Proof test interval of 38 years

\* The safety contacts are described as normally closed (N.C.) i.e., with the guard closed, actuator in place (where relevant) and the machine able to be started.

## Safety Switches

**NEMA Style Switches****802T Direct Opening Action****AC Contact Rating (Maximum per Pole, 50 or 60Hz,  
2 Circuits)**

NEMA Rating Designation	Max Voltage	A		Continuous Carrying Current	VA	
		Make	Break		Make	Break
A600	120	60	6.00	10	7200	720
	240	30	3.00	10	7200	720
AC-15	480	15	1.50	10	7200	720
	600	12	1.20	10	7200	720

**AC Contact Rating (Maximum per Pole, 50 or 60Hz,  
4 Circuits)**

NEMA Rating Designation	Max Voltage	A		Continuous Carrying Current	VA	
		Make	Break		Make	Break
A300	120	60	6.00	10	7200	720
	240	30	3.00	10	7200	720

**DC Contact Rating (Maximum per Pole)**

NEMA Rating Designation	Max Voltage	A		Continuous Carrying Current	VA	
		Make	Break		Make	Break
Q300	250	0.27	0.27	2.5	69	69
	125	0.55	0.55	2.5	69	69
DC 13						

**Low Voltage DC**

24V DC @ 1.1 Amps resistive load

3-Limit  
Switches

## Safety Switches NEMA Style Switches 802T Direct Opening Action

### Range of Operation

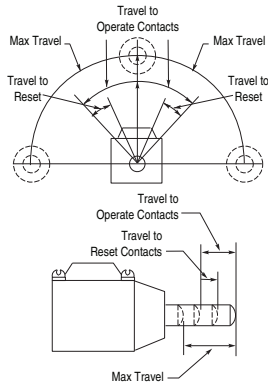

**Lever Type  
Spring Return**



**Top Push Roller  
Spring Return**



**Side Push  
Vertical Roller  
Spring Return**



**Side Push  
Horizontal Roller  
Spring Return**

### Product Selection

Number of Circuits	Lever Movement	Description	Typical Force/Torque to Operate	Travel to Operate Contacts [mm (in.)]	Torque/Force to Operate Direct Opening Action	Travel to Operate Direct Opening Action [mm (in.)]	Maximum Travel [mm (in.)]	Travel to Reset Contacts [mm (in.)]	Cat. No.
<b>Lever Type • Spring Return</b>									
2	Clockwise or Counter Clockwise		0.45 N•m (4.0 lb•in), max.	13°, max.	0.90 N•m (8 lb•in), min.	25°, min.	90°	7°, max.	Switch w/o Lever 802T-APD
4									802T-ATPD
<b>Top Push Roller • Spring Return</b>									
2	Normal	Operated	28.47 N•m (6.4 lb•in), max.	1.17 (0.046), max.	66.72 N (15.0 lb), min.	2.29 (0.090), min.	5.99 (0.236)	0.64 (0.025), max.	Complete Switch 802T-DPD
4									802T-DTPD
<b>Side Push Vertical Roller • Spring Return</b>									
2	Normal	Operated	24.5 N•m (5.5 lb•in), max.	2.08 (0.082), max.	53.4 N (12.0 lb), min.	4.19 (0.165), min.	5.74 (0.226)	1.14 (0.045), max.	Complete Switch 802T-KPD
4									802T-KTPD
<b>Side Push Horizontal Roller • Spring Return</b>									
2	Normal	Operated	24.5 N•m (5.5 lb•in), max.	2.08 (0.082), max.	53.4 N (12.0 lb), min.	4.19 (0.165), min.	5.74 (0.226)	1.14 (0.045), max.	Complete Switch 802T-K1PD
4									802T-K1TPD

3-Limit Switches

Modifications and Typical Levers—page 3-159.

# Safety Switches

## NEMA Style Switches

### 802T Direct Opening Action

#### Typical Example of a Dual Channel Safety Application

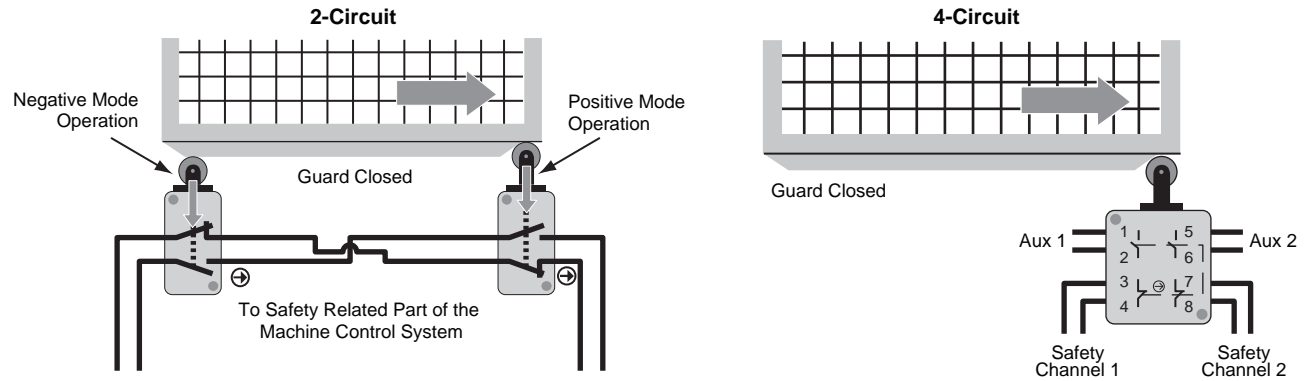

#### Approximate Dimensions [mm (in.)]

Dimensions are not intended to be used for installation purposes.

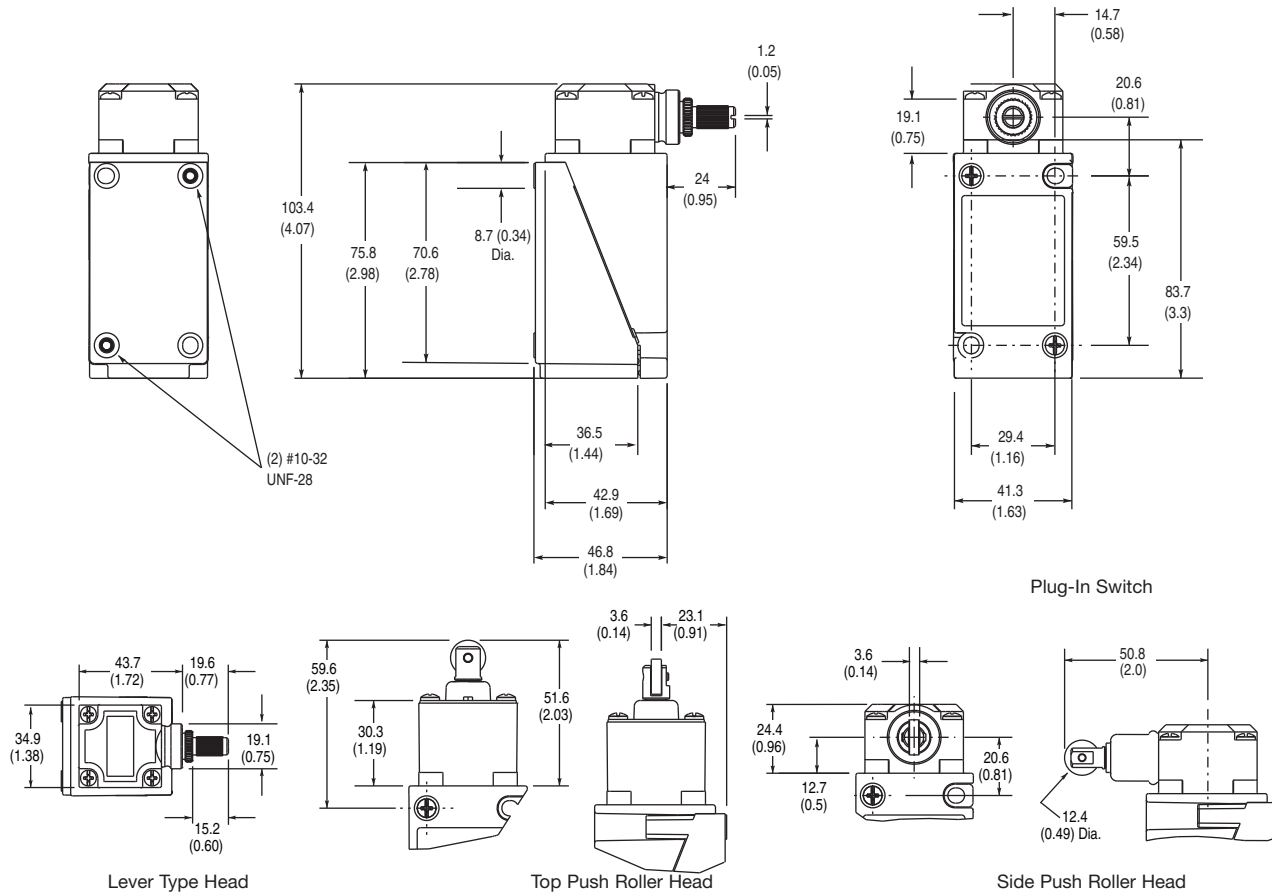

3-Limit Switches

## Safety Switches NEMA Style Switches 802T Direct Opening Action

### Modifications

#### Metric Conduit Entry

To order a limit switch with a 20 mm conduit entry, add the suffix **S6** to the cat. no. **Example: 802T-APDS6.**

#### Pre-wired Cable

To order a factory-installed pre-wired type ST00W-A cable (5-conductor), add the suffix **Y** plus the number of feet required. The standard cable length is 1.52 m (5 ft). Extended cable lengths are available in multiples of 1.22 m (4 ft) only.

**Example:** To order a limit switch with a factory-installed 1.52 m (5 ft) cable, the cat. no. would become **802T-APDY5.** To order a limit switch with a factory-installed 2.44 m (8 ft) cable, the cat. no. would become **802T-APDY8.**

#### Mini-Style Quick-Disconnect

To order an 802T pre-wired limit switch with a 5-pin (2 circuit) or 9-pin (4 circuit) mini connector, add the suffix **J1** or **J9** depending on desired wiring (J9 wiring not available for 4-circuit models) to the cat. no. **Example: 802TAPDJ1.**

#### 5-Pin Mini-Type Receptacle (2 circuit)

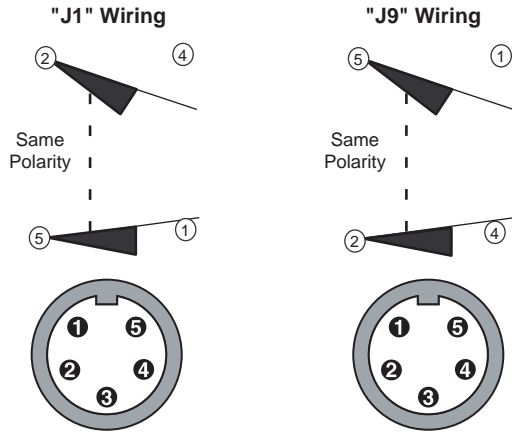

#### 9-Pin Mini-Type Receptacle (4 circuit)

"J1" Wiring ("J9" wiring not available for 4 circuit)

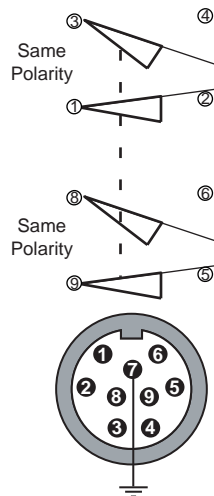

#### Micro-Style Quick-Disconnect

Micro quick-disconnects are available with a 5-pin 2-keyway AC or 5-pin single keyway DC. To order a limit switch with a AC micro quick-disconnect, add the suffix **R5** to the cat. no. To order a limit switch with a DC micro quick-disconnect, add the suffix **D5** to the cat. no. **Example: 802TAPDR5** and **802TAPDD5.**

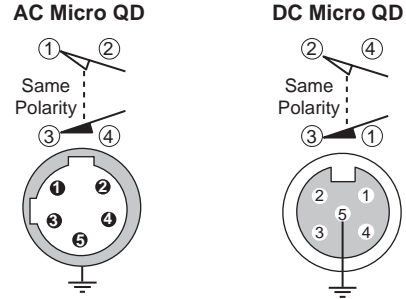

#### Levers

Type	Roller [mm (in.)]			Cat. No.
	Material	Diameter	Width	
	Nylon	19.05 (0.75)	7.11 (0.28)	802T-W1
	Nylon	19.05 (0.75)	25.4 (1.0)	802T-W1H
	Steel	19.05 (0.75)	6.35 (0.25)	802T-W1A
	Ball Bearing	19.05 (0.75)	5.84 (0.23)	802T-W1B

**Non-Adj. Cast Lever**  
**38.1 mm**  
**(1.5 in.)**  
**Radius Roller**  
**on Front**

**Note:** Additional lever options are available in the Limit Switch section of the Sensors catalog.

3-Limit  
Switches



## Safety Switches

### Notes

---

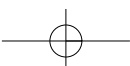
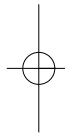
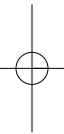



## X-ON Electronics

Largest Supplier of Electrical and Electronic Components

*Click to view similar products for [Emergency Stop Switches / E-Stop Switches](#) category:*

*Click to view products by [Guard Master](#) manufacturer:*

Other Similar products are found below :

[84-5021.2B40](#) [84-6830.0020](#) [A01ESSP8](#) [A22EL-M-24A-11B](#) [AVN302N-R](#) [A165E-S-01\(STOP\)](#) [AYLD2212602SN-R-TK962](#)  
[AVLD39911N-R-24V](#) [A22Z-EG22](#) [A165E-SY](#) [3100.0110Y](#) [3050.1302Y](#) [3SE2243-0XX40](#) [3SK1111-2AB30](#) [3SK1211-1BB40](#) [44-710](#) [84-](#)  
[6841.2B20](#) [84-6830.0040](#) [H3141AAKAA](#) [A165E-R-24D-01](#) [E3102AAAAB](#) [A22E-M-03](#) [ZA2BV05](#) [A22EL-M-T2-01](#) [951FY000-WO](#)  
[ER6022-022N](#) [952+2000-00](#) [ES3S51653](#) [601+0000-OP](#) [E3101AAAAB](#) [84-5130.0040](#) [CS AR-05V024](#) [CS AR-22V024](#) [DS AE1VA](#) [DS](#)  
[KB2A](#) [DS KB3A](#) [HE2G-21SHE-L-K](#) [HE6B-M211Y](#) [774191](#) [774316](#) [777760](#) [R1.100.0129.0 SMA0129- NO/NO](#) [R1.188.0640.0 SNV](#)  
[4063KL-A](#) [R1.188.1810.0 SNA 4043K-A](#) [R1.188.1840.0 SNA 4043K-A](#) [SR BD40ALK-B02F](#) [AVLW39911D-R-120V](#) [AYD311NUG](#)  
[AVLD32211DNUR](#) [84-5040.0020.0049](#)