

⊕ 0.00 [.000] M D M E M TYP

- ① HOUSING: HIGH TEMPERATURE THERMOPLASTIC. COLOR - NATURAL
- ② CONTACT: PHOSPHOR BRONZE.
- ③ METAL HOLD DOWN: BRASS
- ④ CONTACT FINISH: .001269 [.000050] MIN NICKEL ALL OVER. GOLD FLASH OVER NICKEL IN CONTACT AREA. .002537 [.000100] MIN MATTE TIN OVER NICKEL ON SOLDER TAILS.
- ⑤ CONTACT FINISH: .001269 [.000050] MIN NICKEL ALL OVER. .000375 [.000015] GOLD OVER NICKEL IN CONTACT AREA. .002537 [.000100] MIN MATTE TIN OVER NICKEL ON SOLDER TAILS.
- ⑥ CONTACT FINISH: .001269 [.000050] MIN NICKEL ALL OVER. .000757 [.000030] GOLD OVER NICKEL IN CONTACT AREA. .002537 [.000100] MIN MATTE TIN OVER NICKEL ON SOLDER TAILS.
- ⑦ DISTANCE FROM CONTACT POINT TO BOTTOM OF CARD SLOT.
- ⑧ METAL HOLD DOWN FINISH: .001269 [.000050] MIN NICKEL ALL OVER, .003809 [.000150] MIN MATTE TIN ALL OVER.
- ⑨ AMP PART NUMBER, DATE CODE AND CSA LOGO MARKED IN APPROXIMATE LOCATION SHOWN.
- ⑩ CORED OR SOLID SIDE WALLS ARE AT DISCRETION OF AMP INCORPORATED.
- ⑪ HOUSING: HIGH TEMPERATURE THERMOPLASTIC COLOR- GREEN, PANTONE COLORS 355C OR 365C
- ⑫ HOUSING: HIGH TEMPERATURE THERMOPLASTIC COLOR: BLACK
- ⑬ OBSOLETE PARTS: OBSOLETE CIS STREAMLINING PER D.RENAUD/D.SINISI

SEE SHEET 2 FOR HOLE PATTERN

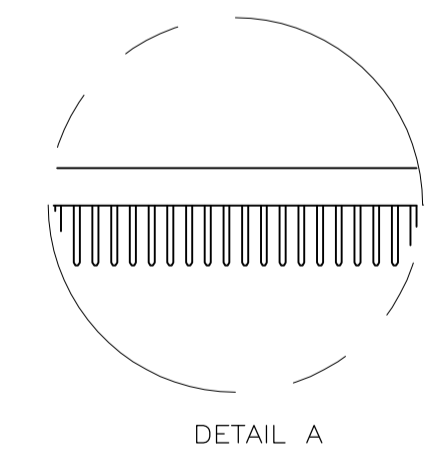

⑬ OBSOLETE	⑫ 2.54 [.100]	⑪ 2-5145168-9
	⑩ 3.18 [.125]	⑨ 2-5145168-8
	⑧ 3.56 [.140]	⑦ 1-5145168-2
	⑥ 3.18 [.125]	⑤ 5145168-8
	⑤ 2.54 [.100]	④ 5145168-4
	④ 2.54 [.100]	③ 5145168-2
	③ 2.54 [.100]	② 5145168-1
HSG MATL	W	FINISH
		PART NUMBER

THIS DRAWING IS A CONTROLLED DOCUMENT.

DIMENSIONS: mm	TOLERANCES UNLESS OTHERWISE SPECIFIED:	0 PLC ± -	1 PLC ± -	2 PLC ± 0.25 [.01]	3 PLC ± 0.127 [.005]	4 PLC ± ± Z	ANGLES ± ± Z
MATERIAL	FINISH	WEIGHT	SIZE	CAGE CODE	DRAWING NO	RESTRICTED TO	
AL FRANTUM	22 JAN 05	AL FRANTUM	22 JAN 05	AL FRANTUM	25JULY2006	NAME	
S.FLICKINGER	108-14034	APPLICATION SPEC	114-26012	SIZE	CAGE CODE	DRAWING NO	
114-26012	A1	00779	5145168	SCALE	4:1	SHEET 1 OF 2	
CUSTOMER DRAWING	SCALE	4:1	SHEET	1 OF 2	REV	B2	

STE TE Connectivity

CONNECTOR ASSEMBLY, 92 DUAL POSITION, 1.27 (.050) SERIES



## X-ON Electronics

Largest Supplier of Electrical and Electronic Components

*Click to view similar products for [PCI Express/PCI Connectors](#) category:*

*Click to view products by [TE Connectivity](#) manufacturer:*

Other Similar products are found below :

[UEX220-6U](#) [0877159203](#) [10039755-10110TLF](#) [10039755-10211TLF](#) [10025026-10003PLF](#) [10125756-A41010LF](#) [10125756-980000LF](#) [1-1871239-2](#) [2170560-2](#) [10082378-11003TLF](#) [10125756-980000LF](#) [1775861-2](#) [10039755-10111TLF](#) [EB220-3U](#) [WD2M144WB2R300](#)  
[10061913-120PLF](#) [10108777-10002WLF](#) [GPCP146400111HR](#) [10144667-112Y0LF](#) [10144667-113Y0LF](#) [205058-1001](#) [GPCP446200120HR](#)  
[GPCP245400111HR](#) [10082378-10000TLF](#) [10082378-10001TLF](#) [87715-9256](#) [MDT580M03001](#) [0877159107](#) [205058-1003](#) [MDT580M01001](#)  
[10018783-11000MLF](#) [10061913-103BLF](#) [10145445-10003MLF](#) [PSASF2130311TR](#) [10147430-113T0LF](#) [10146070-113Y0LF](#)  
[MDT670M01005](#) [10108777-10200MLF](#) [MDT420M01002](#) [PSASF3130211TR](#) [PSASF4130051TR](#) [PSASM2130412TR](#) [PSASM2130391TR](#)  
[10139595-111T0LF](#) [10139595-110T0LF](#) [PSASF3130131TR](#) [0745400501](#) [7-1734774-7](#) [10150900-052R2LF](#) [3-1761465-1](#)