

Bombardier Transportation Design Guide for Amphenol® GT Series Reverse Bayonet Coupling Connectors

L-2123

Date: 10-01-2004



Amphenol

Table of Contents

	Page No.
Amphenol GT Connectors with Reverse Bayonet Coupling for Bombardier - General Description	1
Insert Availability, Alternate Positioning	2
Contact Arrangements	3, 4
Part Number Description	5
Part Numbers Receptacles	6
Part Numbers Straight Plugs	7
Part Numbers Angle Plugs	8
Shell Styles for Bombardier	
GT030 Square Flange Receptacle for Rear Panel Mounting	9
GT030RV Square Flange Receptacle for Rear Panel Mounting	10
GT06F Straight Plug	11
GT06CFZ Straight Plug	12
GT06RV Straight Plug	13
GT08F 90° Angle Plug	14
GT08CFZ 90° Angle Plug	15
Accessories for Bombardier	
Sealing Gaskets	16
Receptacle Protection Caps	17
Plug Protection Caps	18
Rear Mounting Data, Panel Cut-out Dimensions, Sealing Plugs, Sealing Ranges, Backshell Torque Forces	19
Crimp Contacts	20, 21

Amphenol® GT Connectors with reverse bayonet coupling for Bombardier

The GT Connector is the preferred connector for the mass transit industry. It was chosen by Bombardier for its heavy duty features and its proven reliability.

This publication was designed for use by Bombardier and Bombardier subcontractors. It is the intention of Amphenol to supply this information in order to simplify the ordering processes of Bombardier for GT Reverse Bayonet connectors. It will be updated as needed to provide the most current information.

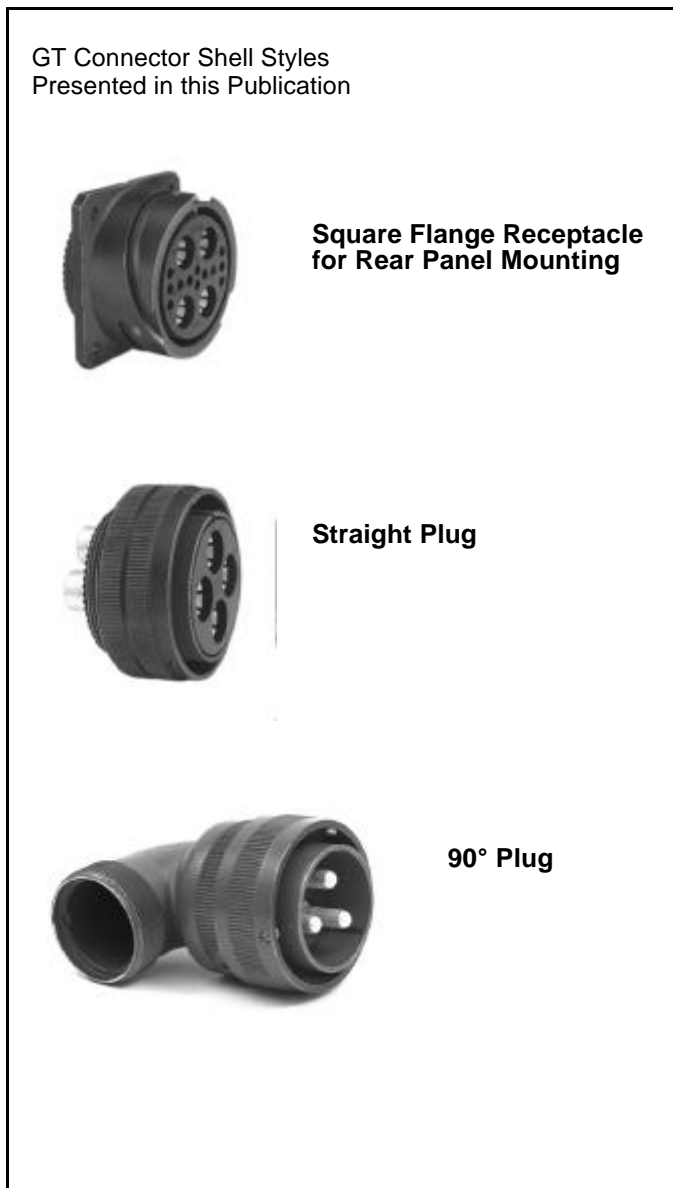

Amphenol® GT Reverse Bayonet Coupling Connectors Features:

- Quick positive coupling
- Audible, tactile and visual indication of full coupling
- Waterproof
- No lockwiring required
- High shock and vibration capabilities
- Inserts are made from low smoke/flame retardant or Neoprene
- Operating temperature range:
-55°C to +125°C
- Available in both crimp and solder terminations
- Contacts available in gold and silver plating
- Numerous finishes available
- Black zinc alloy plating (cadmium free) available
- Rugged construction; aluminum or stainless steel components
- Intermateable with existing VG95234 connectors
- 2000 couplings minimum
- UL recognized

For further information on GT Connectors consult Amphenol catalog 12-024 or contact:

Amphenol Corporation
Amphenol Industrial Operations
40-60 Delaware Avenue
Sidney, New York 13838-1395
Phone: 607-563-5011 Fax: 607-563-5351
www.amphenol-industrial.com

GT Series for Bombardier

insert availability and alternate positioning

INSERT AVAILABILITY

Insert Arrangement	Service Rating	Total Contacts	Contact Size							
			0	4	8	12	16	2/0	4/0	
10SL-3	A	3						3		
14S-6	Inst.	6						6		
16S-1	A	7						7		
16-10	A	3					3			
18-1	A/Inst.	10						10		
18-11	A	5					5			
18-12	A	6						6		
20-4	D	4					4			
20-29	A	17						17		
22-2	D	3			3					
22-14	A	19						19		
24-22	D	4			4					
24-96	Inst.	28						28		
28-6	D	3		3						
28-21	A	37						37		
28-22	D	6		3				3		
28-84	A	9			9					
32-AF	A	55						55		
36-10	A	48						48		
40-35	D	35					35			
40-56	A	85						85		
40-AP	E	2								2
40-AS	A	40					25	15		
40-AT	A	43			1	24	18			
40-AV	D	3							3	

ALTERNATE POSITIONING

To avoid cross-plugging problems in applications requiring the use of more than one connector of the same size and arrangement, alternate rotations are available as indicated in the chart below.

As shown in the diagram below, the front face of the pin insert is rotated within the shell in a clockwise direction from the normal shell key. The socket insert would be rotated counter-clockwise the same number of degrees in respect to the normal shell key.

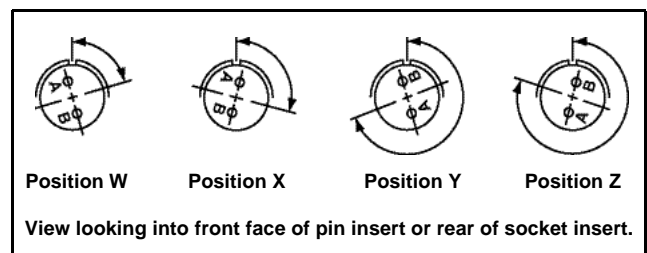

Insert Arrangement	Degrees			
	W	X	Y	Z
16-10	90	180	270	-
16S-1	80	-	-	280
18-1	70	145	215	290
18-11	-	170	265	-
18-12	80	-	-	280
20-4	45	110	250	-
20-29	80	-	-	280
22-2	70	145	215	290
22-14	80	110	250	280
24-22	45	110	250	-
24-96	65	-	-	-
28-6	70	145	215	290
28-21	80	110	250	280
28-22	70	145	215	290
32-AF	80	110	250	280
36-10	80	125	235	280
40-35	70	130	230	290
40-56	72	144	216	288

Additional rotations available; consult Amphenol for information.

GT Series for Bombardier contact arrangements

front face of pin insert or rear face of socket insert illustrated

	Front of Socket Insert				
Insert Arrangement	10SL-3	14S-6	16S-1	16-10	18-1
Service Rating	A	Inst.	A	A	B, C, F, G = A; Bal. = Inst.
Number of Contacts	3	6	7	3	10
Contact Size	16	16	16	12	16
Insert Arrangement	18-11	18-12	20-4	20-29	22-2
Service Rating	A	A	D	A	D
Number of Contacts	5	6	4	17	3
Contact Size	12	16	12	16	8
Insert Arrangement	22-14	24-22	24-96	28-6	28-21
Service Rating	A	D	Inst.	D	A
Number of Contacts	19	4	28	3	37
Contact Size	16	8	16	4	16
Insert Arrangement	28-22	28-84	32-AF	36-10	
Service Rating	D	A	A	A	
Number of Contacts	3 3	9	55	48	
Contact Size	4 16	8	16	16	

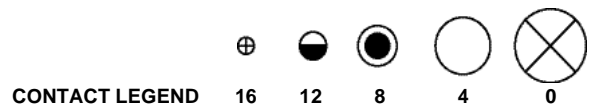

GT Series for Bombardier contact arrangements

front face of pin insert or rear face of socket insert illustrated

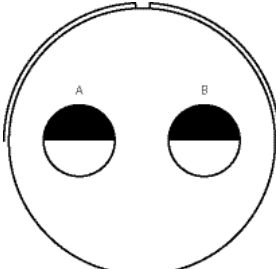
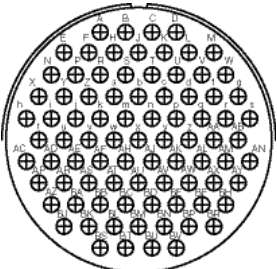
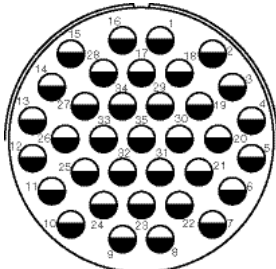

Insert Arrangement
Service Rating
Number of Contacts
Contact Size

40-35
D
35
12

40-56
A
85
16

40-AP
E
2
4/0

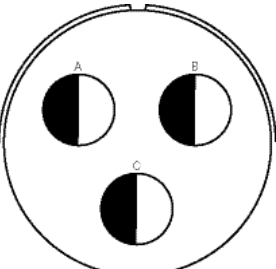
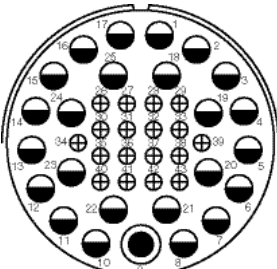
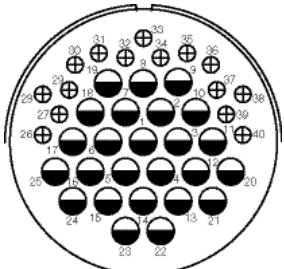

Insert Arrangement
Service Rating
Number of Contacts
Contact Size

40-AS
A
25 15
12 16

40-AT
A
1 24 18
8 12 16

40-AV
D
3
2/0

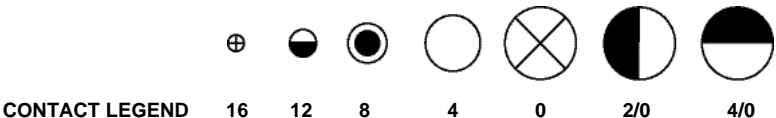

GT Connectors for Bombardier

part number description

Amphenol GT Part Number System

GT	CL	030	RV	FF	36-10	P	W	(025)
1	2	3	4	5	6	7	8	

1. Contact Style and Insert Material

CL = Crimp with low smoke/flame retardant inserts

2. Shell Style

030 - Square flange receptacle - rear panel mount

06 - Straight plug

08 - 90° angle plug

3. Connector Class - For details see pictorial description at right and see pages X-X for detailed drawings.

No letter designates connector with no adapter, but with threaded rear to accept an accessory attachment.

CFZ - Adapter, jacketed cable clamp, individual wire sealing grommet, environmental

F - Adapter, clamp for individual wires, individual wire sealing grommet, environmental.

RV - Adapter, individual wire sealing grommet, environmental

4. Designation for Mounting Holes Receptacle Only

FF - UN Threads (consult Amphenol)

FM - Metric Threads (consult Amphenol)

No designation for standard through mounting holes.

5. Shell Size and Arrangement

See page 2.

6. Contact Style

P designates pin contacts

S designates socket contacts

7. Alternate Position

W, X, Y and Z - See page 2.

No suffix required for normal position.

8. Connector Modification

(025) Black zinc cobalt

(LC) Less contacts

PICTORIAL DESCRIPTION OF GT CLASSES

RECEPTACLES: GT030, GT030RV

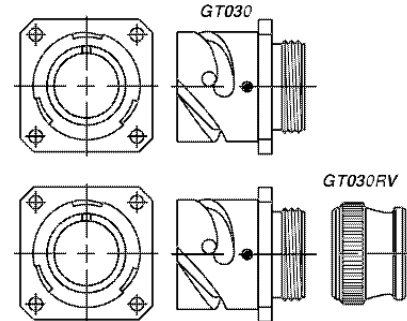

STRAIGHT PLUGS: GT06F, GT06CFZ, GT06RV

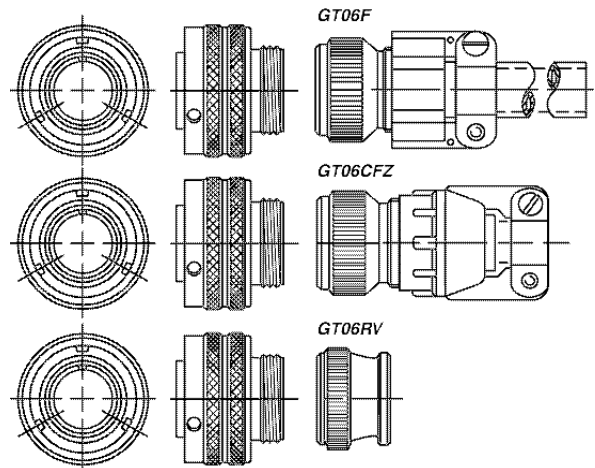

90° PLUGS: GT08F, GT08CFZ

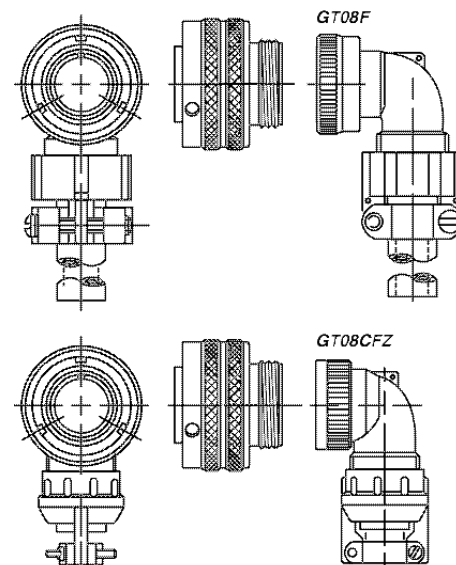

GT Connectors for Bombardier

Amphenol part numbers, receptacles

GT030
Square Flange Receptacle

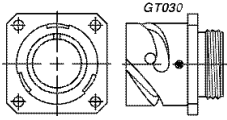

GTCL03010SL-3(P/S)(025)(LC)
GTCL03014S-6(P/S)(025)(LC)
GTCL03016S-1(P/S)(025)(LC)
GTCL03016-10(P/S)(025)(LC)
GTCL03018-1(P/S)(025)(LC)
GTCL03018-11(P/S)(025)(LC)
GTCL03018-12(P/S)(025)(LC)
GTCL03020-4(P/S)(025)(LC)
GTCL03020-29(P/S)(025)(LC)
GTCL03022-2(P/S)(025)(LC)
GTCL03022-14(P/S)(025)(LC)
GTCL03024-22(P/S)(025)(LC)
GTCL03024-96(P/S)(025)(LC)
GTCL03028-6(P/S)(025)(LC)
GTCL03028-21(P/S)(025)(LC)
GTCL03028-22(P/S)(025)(LC)
GTCL03028-84(P/S)(025)(LC)
GTCL03032-AF(P/S)(025)(LC)
GTCL03036-10(P/S)(025)(LC)
GTCL03040-35(P/S)(025)(LC)
GTCL03040-56(P/S)(025)(LC)
GTCL03040-AP(P/S)(025)(LC)
GTCL03040-AS(P/S)(025)(LC)
GTCL03040-AT(P/S)(025)(LC)
GTCL03040-AV(P/S)(025)(LC)

GT030RV
Square Flange Receptacle

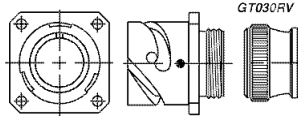

GTCL030RV10SL-3(P/S)(025)(LC)
GTCL030RV14S-6(P/S)(025)(LC)
GTCL030RV16S-1(P/S)(025)(LC)
GTCL030RV16-10(P/S)(025)(LC)
GTCL030RV18-1(P/S)(025)(LC)
GTCL030RV18-11(P/S)(025)(LC)
GTCL030RV18-12(P/S)(025)(LC)
GTCL030RV20-4(P/S)(025)(LC)
GTCL030RV20-29(P/S)(025)(LC)
GTCL030RV22-2(P/S)(025)(LC)
GTCL030RV22-14(P/S)(025)(LC)
GTCL030RV24-22(P/S)(025)(LC)
GTCL030RV24-96(P/S)(025)(LC)
GTCL030RV28-6(P/S)(025)(LC)
GTCL030RV28-21(P/S)(025)(LC)
GTCL030RV28-22(P/S)(025)(LC)
GTCL030RV28-84(P/S)(025)(LC)
GTCL030RV32-AF(P/S)(025)(LC)
GTCL030RV36-10(P/S)(025)(LC)
GTCL030RV40-35(P/S)(025)(LC)
GTCL030RV40-56(P/S)(025)(LC)
GTCL030RV40-AP(P/S)(025)(LC)
GTCL030RV40-AS(P/S)(025)(LC)
GTCL030RV40-AT(P/S)(025)(LC)
GTCL030RV40-AV(P/S)(025)(LC)

See page 5 for complete description of how the Amphenol part numbers are built.

GT Connectors for Bombardier

Amphenol part numbers, straight plugs

GT06F
Straight Plug

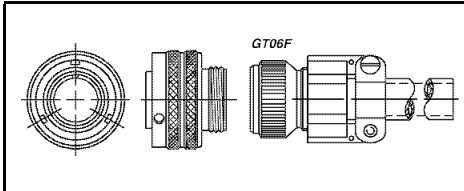

GTCL06F10SL-3(P/S)(025)(LC)
GTCL06F14S-6(P/S)(025)(LC)
GTCL06F16S-1(P/S)(025)(LC)
GTCL06F16-10(P/S)(025)(LC)
GTCL06F18-1(P/S)(025)(LC)
GTCL06F18-11(P/S)(025)(LC)
GTCL06F18-12(P/S)(025)(LC)
GTCL06F20-4(P/S)(025)(LC)
GTCL06F20-29(P/S)(025)(LC)
GTCL06F22-2(P/S)(025)(LC)
GTCL06F22-14(P/S)(025)(LC)
GTCL06F24-22(P/S)(025)(LC)
GTCL06F24-96(P/S)(025)(LC)
GTCL06F28-6(P/S)(025)(LC)
GTCL06F28-21(P/S)(025)(LC)
GTCL06F28-22(P/S)(025)(LC)
GTCL06F28-84(P/S)(025)(LC)
GTCL06F32-AF(P/S)(025)(LC)
GTCL06F36-10(P/S)(025)(LC)
GTCL06F40-35(P/S)(025)(LC)
GTCL06F40-56(P/S)(025)(LC)
GTCL06F40-AP(P/S)(025)(LC)
GTCL06F40-AS(P/S)(025)(LC)
GTCL06F40-AT(P/S)(025)(LC)
GTCL06F40-AV(P/S)(025)(LC)

GT06CFZ
Straight Plug

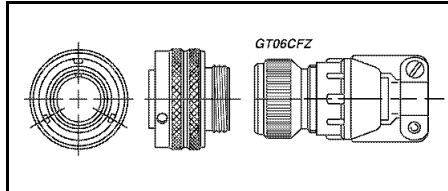

GTCL06CFZ10SL-3(P/S)(025)(LC)
GTCL06CFZ14S-6(P/S)(025)(LC)
GTCL06CFZ16S-1(P/S)(025)(LC)
GTCL06CFZ16-10(P/S)(025)(LC)
GTCL06CFZ18-1(P/S)(025)(LC)
GTCL06CFZ18-11(P/S)(025)(LC)
GTCL06CFZ18-12(P/S)(025)(LC)
GTCL06CFZ20-4(P/S)(025)(LC)
GTCL06CFZ20-29(P/S)(025)(LC)
GTCL06CFZ22-2(P/S)(025)(LC)
GTCL06CFZ22-14(P/S)(025)(LC)
GTCL06CFZ24-22(P/S)(025)(LC)
GTCL06CFZ24-96(P/S)(025)(LC)
GTCL06CFZ28-6(P/S)(025)(LC)
GTCL06CFZ28-21(P/S)(025)(LC)
GTCL06CFZ28-22(P/S)(025)(LC)
GTCL06CFZ28-84(P/S)(025)(LC)
GTCL06CFZ32-AF(P/S)(025)(LC)
GTCL06CFZ36-10(P/S)(025)(LC)
GTCL06CFZ40-35(P/S)(025)(LC)
GTCL06CFZ40-56(P/S)(025)(LC)
GTCL06CFZ40-AP(P/S)(025)(LC)
GTCL06CFZ40-AS(P/S)(025)(LC)
GTCL06CFZ40-AT(P/S)(025)(LC)
GTCL06CFZ40-AV(P/S)(025)(LC)

GT06RV
Straight Plug

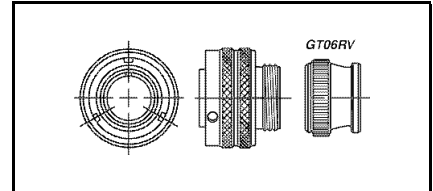

GTCL06RV10SL-3(P/S)(025)(LC)
GTCL06RV14S-6(P/S)(025)(LC)
GTCL06RV16S-1(P/S)(025)(LC)
GTCL06RV16-10(P/S)(025)(LC)
GTCL06RV18-1(P/S)(025)(LC)
GTCL06RV18-11(P/S)(025)(LC)
GTCL06RV18-12(P/S)(025)(LC)
GTCL06RV20-4(P/S)(025)(LC)
GTCL06RV20-29(P/S)(025)(LC)
GTCL06RV22-2(P/S)(025)(LC)
GTCL06RV22-14(P/S)(025)(LC)
GTCL06RV24-22(P/S)(025)(LC)
GTCL06RV24-96(P/S)(025)(LC)
GTCL06RV28-6(P/S)(025)(LC)
GTCL06RV28-21(P/S)(025)(LC)
GTCL06RV28-22(P/S)(025)(LC)
GTCL06RV28-84(P/S)(025)(LC)
GTCL06RV32-AF(P/S)(025)(LC)
GTCL06RV36-10(P/S)(025)(LC)
GTCL06RV40-35(P/S)(025)(LC)
GTCL06RV40-56(P/S)(025)(LC)
GTCL06RV40-AP(P/S)(025)(LC)
GTCL06RV40-AS(P/S)(025)(LC)
GTCL06RV40-AT(P/S)(025)(LC)
GTCL06RV40-AV(P/S)(025)(LC)

See page 5 for complete description of how the Amphenol part numbers are built.

GT Connectors for Bombardier

Amphenol part numbers, 90° angle plugs

GT08F
90° Angle Plug

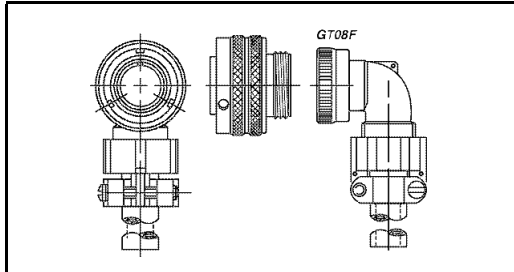

GTCL08F10SL-3(P/S)(025)(LC)
GTCL08F14S-6(P/S)(025)(LC)
GTCL08F16S-1(P/S)(025)(LC)
GTCL08F16-10(P/S)(025)(LC)
GTCL08F18-1(P/S)(025)(LC)
GTCL08F18-11(P/S)(025)(LC)
GTCL08F18-12(P/S)(025)(LC)
GTCL08F20-4(P/S)(025)(LC)
GTCL08F20-29(P/S)(025)(LC)
GTCL08F22-2(P/S)(025)(LC)
GTCL08F22-14(P/S)(025)(LC)
GTCL08F24-22(P/S)(025)(LC)
GTCL08F24-96(P/S)(025)(LC)
GTCL08F28-6(P/S)(025)(LC)
GTCL08F28-21(P/S)(025)(LC)
GTCL08F28-22(P/S)(025)(LC)
GTCL08F28-84(P/S)(025)(LC)
GTCL08F32-AF(P/S)(025)(LC)
GTCL08F36-10(P/S)(025)(LC)
GTCL08F40-35(P/S)(025)(LC)
GTCL08F40-56(P/S)(025)(LC)
GTCL08F40-AP(P/S)(025)(LC)
GTCL08F40-AS(P/S)(025)(LC)
GTCL08F40-AT(P/S)(025)(LC)
GTCL08F40-AV(P/S)(025)(LC)

GT08CFZ
90° Angle Plug

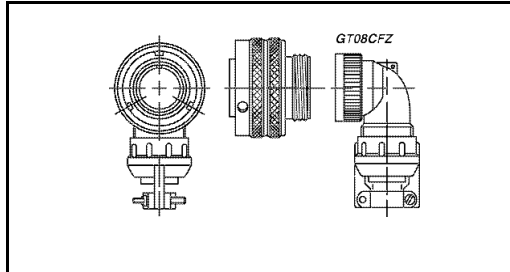

GTCL08CFZ10SL-3(P/S)(025)(LC)
GTCL08CFZ14S-6(P/S)(025)(LC)
GTCL08CFZ16S-1(P/S)(025)(LC)
GTCL08CFZ16-10(P/S)(025)(LC)
GTCL08CFZ18-1(P/S)(025)(LC)
GTCL08CFZ18-11(P/S)(025)(LC)
GTCL08CFZ18-12(P/S)(025)(LC)
GTCL08CFZ20-4(P/S)(025)(LC)
GTCL08CFZ20-29(P/S)(025)(LC)
GTCL08CFZ22-2(P/S)(025)(LC)
GTCL08CFZ22-14(P/S)(025)(LC)
GTCL08CFZ24-22(P/S)(025)(LC)
GTCL08CFZ24-96(P/S)(025)(LC)
GTCL08CFZ28-6(P/S)(025)(LC)
GTCL08CFZ28-21(P/S)(025)(LC)
GTCL08CFZ28-22(P/S)(025)(LC)
GTCL08CFZ28-84(P/S)(025)(LC)
GTCL08CFZ32-AF(P/S)(025)(LC)
GTCL08CFZ36-10(P/S)(025)(LC)
GTCL08CFZ40-35(P/S)(025)(LC)
GTCL08CFZ40-56(P/S)(025)(LC)
GTCL08CFZ40-AP(P/S)(025)(LC)
GTCL08CFZ40-AS(P/S)(025)(LC)
GTCL08CFZ40-AT(P/S)(025)(LC)
GTCL08CFZ40-AV(P/S)(025)(LC)

See page 5 for complete description of how the Amphenol part numbers are built.

GT030 for Bombardier

square flange receptacle for rear panel mounting

- Four through mounting holes or optional threaded holes
- Threaded rear to accept accessory attachment
- Environment proof when mounted with a proper sealing gasket (see page 16)

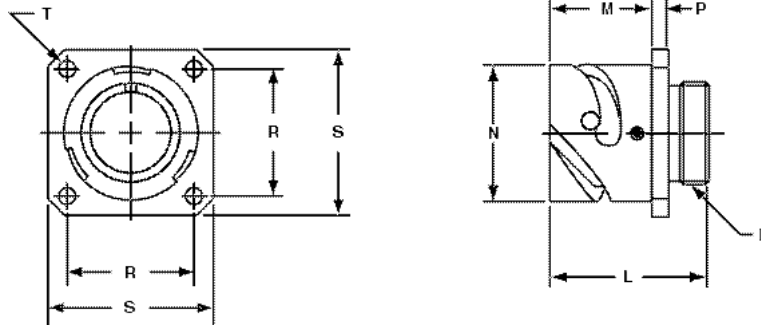

Inches

Shell Size	B Thread Class 2A	L ± .012	M + .016 - .000	N + .000 - .006	P ± .008	R ± .004	S ± .012	T + .004 - .000
10SL	.6250-24UNEF	1.087	.717	.717	.110	.717	1.000	.126
14S	.7500-20UNEF	1.087	.717	.969	.126	.906	1.181	.126
16S	.8750-20UNEF	1.087	.717	1.079	.126	.969	1.280	.126
16	.8750-20UNEF	1.331	.846	1.079	.126	.969	1.280	.126
18	1.0000-20UNEF	1.331	.907	1.213	.157	1.063	1.378	.126
20	1.1250-18UNEF	1.331	.907	1.346	.157	1.157	1.496	.126
22	1.2500-18UNEF	1.331	.907	1.472	.157	1.252	1.614	.126
24	1.3750-18UNEF	1.331	.907	1.610	.157	1.374	1.752	.146
28	1.6250-18UNEF	1.406	.947	1.839	.157	1.563	2.000	.146
32	1.8750-16UN	1.469	.947	2.102	.157	1.752	2.244	.169
36	2.0625-16UN	1.469	.947	2.346	.157	1.937	2.500	.169
40	2.3125-16UN	1.469	.947	2.579	.157	2.185	2.752	.169

Millimeters

Shell Size	L ± 0.3	M + 0.4 - 0.0	N + 0.00 - 0.15	P ± 0.2	R ± 0.1	S ± 0.3	T + 0.1 - 0.0
10SL	27.6	18.2	18.2	2.8	18.2	25.4	3.2
14S	27.6	18.2	24.6	3.2	23.0	30.0	3.2
16S	27.6	18.2	27.4	3.2	24.6	32.5	3.2
16	33.8	21.5	27.4	3.2	24.6	32.5	3.2
18	33.8	23.05	30.8	4.0	27.0	35.0	3.2
20	33.8	23.05	34.2	4.0	29.4	38.0	3.2
22	33.8	23.05	37.4	4.0	31.8	41.0	3.2
24	33.8	23.05	40.9	4.0	34.9	44.5	3.7
28	35.7	24.05	46.7	4.0	39.7	50.8	3.7
32	37.3	24.05	53.4	4.0	44.5	57.0	4.3
36	37.3	24.05	59.6	4.0	49.2	63.5	4.3
40	37.3	24.05	65.5	4.0	55.5	69.9	4.3

All dimensions for reference only.

GT030RV for Bombardier

square flange receptacle for rear panel mounting

- Four through mounting holes or optional threaded holes
- With wire sealing grommet for individual wires
- Environment proof

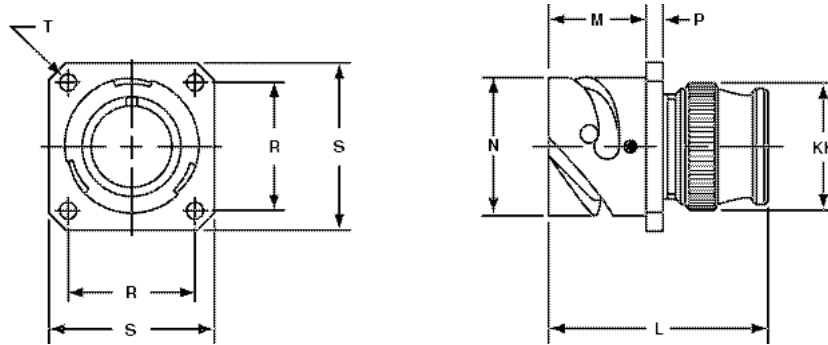

Inches

Shell Size	L Max.	M + .016 - .000	N + .000 - .006	P ± .008	R ± .004	S ± .012	T + .004 - .000	KK Max.
10SL	1.890	.717	.717	.110	.717	1.000	.126	.787
14S	1.890	.717	.969	.126	.906	1.181	.126	.945
16S	1.890	.717	1.079	.126	.969	1.280	.126	1.024
16	2.205	.846	1.079	.126	.969	1.280	.126	1.024
18	2.244	.907	1.213	.157	1.063	1.378	.126	1.161
20	2.244	.907	1.346	.157	1.157	1.496	.126	1.299
22	2.244	.907	1.472	.157	1.252	1.614	.126	1.417
24	2.244	.907	1.610	.157	1.374	1.752	.146	1.575
28	2.244	.947	1.839	.157	1.563	2.000	.146	1.811
32	2.362	.947	2.102	.157	1.752	2.244	.169	2.028
36	2.362	.947	2.346	.157	1.937	2.500	.169	2.283
40	2.362	.947	2.579	.157	2.185	2.752	.169	2.539

Millimeters

Shell Size	L Max.	M + 0.4 - 0.0	N + 0.00 - 0.15	P ± 0.2	R ± 0.1	S ± 0.3	T + 0.1 - 0.0	KK Max.
10SL	48.0	18.20	18.2	2.8	18.2	25.4	3.2	20.0
14S	48.0	18.20	24.6	3.2	23.0	30.0	3.2	24.0
16S	48.0	18.20	27.4	3.2	24.6	32.5	3.2	26.0
16	56.0	21.50	27.4	3.2	24.6	32.5	3.2	26.0
18	57.0	23.05	30.8	4.0	27.0	35.0	3.2	29.5
20	57.0	23.05	34.2	4.0	29.4	38.0	3.2	33.0
22	57.0	23.05	37.4	4.0	31.8	41.0	3.2	36.0
24	57.0	23.05	40.9	4.0	34.9	44.5	3.7	40.0
28	57.0	24.05	46.7	4.0	39.7	50.8	3.7	46.0
32	60.0	24.05	53.4	4.0	44.5	57.0	4.3	51.5
36	60.0	24.05	59.6	4.0	49.2	63.5	4.3	58.0
40	60.0	24.05	65.5	4.0	55.5	69.9	4.3	64.5

All dimensions for reference only.

GT06F for Bombardier straight plug

- With a wire sealing grommet and cable clamp
- For use with individual wires
- Environment proof

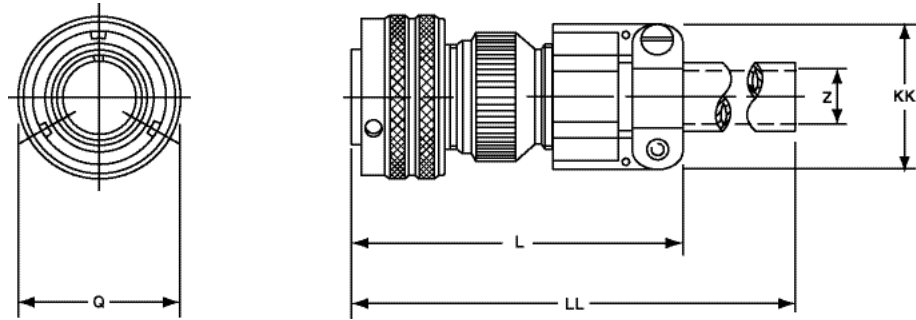

Inches

Shell Size	L Max.	Q Max.	Z Nominal	KK Max.	LL Max.
10SL	2.165	.898	.220	.894	4.724
14S	2.362	1.150	.312	1.083	4.724
16S	2.756	1.260	.437	1.181	4.724
16	2.756	1.260	.437	1.181	4.921
18	2.953	1.437	.562	1.299	4.921
20	2.953	1.571	.625	1.476	4.921
22	2.953	1.697	.625	1.476	4.921
24	3.543	1.835	.750	1.705	4.921
28	3.543	2.102	.750	1.705	4.921
32	3.543	2.366	.937	2.035	4.921
36	3.937	2.610	1.250	2.283	5.315
40	4.921	2.850	1.375	2.579	5.709

Millimeters

Shell Size	L Max.	Q Max.	Z Nominal	KK Max.	LL Max.
10SL	55	22.8	5.58	22.7	120
14S	60	29.2	7.92	27.5	120
16S	70	32.0	11.09	30.0	120
16	70	32.0	11.09	30.0	125
18	75	36.5	14.27	33.0	125
20	75	39.9	15.87	37.5	125
22	75	43.1	15.87	37.5	125
24	90	46.6	19.05	43.3	125
28	90	53.4	19.05	43.3	125
32	90	60.1	23.79	51.7	125
36	100	66.3	31.75	58.0	135
40	125	72.4	34.92	65.5	145

All dimensions for reference only.

GT06CFZ for Bombardier straight plug

- With a wire sealing grommet
- With a cable clamp and seal
- For use with jacketed cable
- Environment proof

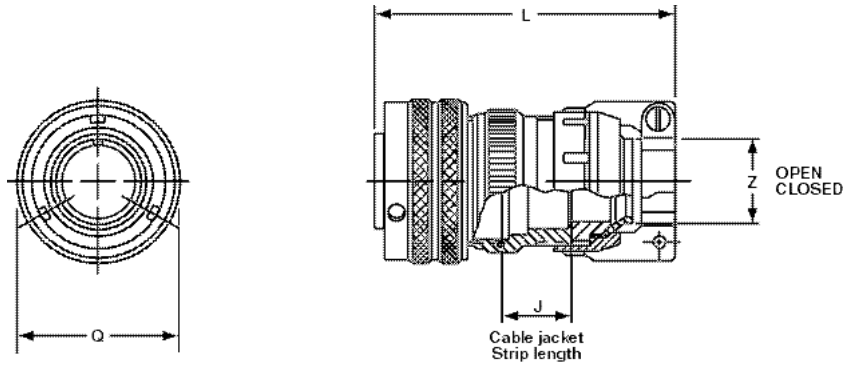

Inches

Shell Size	J Approx.	L Approx.	Q Max.	Z	
				Open	Closed
10SL	.551	2.752	.898	.312	.094
14S	.732	2.898	1.150	.438	.230
16S	.732	2.898	1.260	.531	.315
16	.653	3.216	1.260	.531	.315
18	.705	3.307	1.437	.625	.378
20	.705	3.311	1.571	.748	.445
22	.744	3.350	1.697	.748	.445
24	.689	3.484	1.835	.937	.610
28	.921	3.736	2.102	.937	.610
32	1.016	4.142	2.366	1.250	.921
36	1.031	4.390	2.610	1.378	.921
40	1.614	4.640	2.854	1.624	1.177

Millimeters

Shell Size	J Approx.	L Approx.	Q Max.	Z	
				Open	Closed
10SL	14.0	69.6	22.8	7.93	2.38
14S	18.6	73.6	29.2	11.12	5.84
16S	18.6	73.6	32.0	13.48	8.00
16	16.6	81.7	32.0	13.48	8.00
18	17.9	84.0	36.5	15.87	9.60
20	17.9	84.1	39.9	19.00	11.30
22	18.9	85.1	43.1	19.00	11.30
24	17.5	88.5	46.6	23.80	15.50
28	23.4	94.9	53.4	23.80	15.50
32	25.8	105.2	60.1	31.75	23.40
36	26.2	111.5	66.3	35.00	23.40
40	41.0	111.5	72.5	41.25	29.90

All dimensions for reference only.

GT06RV for Bombardier straight plug

- With a wire sealing grommet
- For use with individual wires
- Environment proof

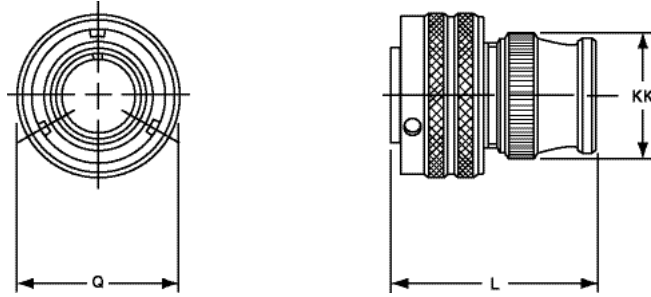

Inches

Shell Size	L Max.	Q Max.	KK Max.
10SL	1.417	.898	.787
14S	1.437	1.150	.945
16S	1.437	1.260	1.024
16	1.929	1.260	1.024
18	1.929	1.437	1.161
20	1.969	1.571	1.299
22	1.969	1.697	1.417
24	2.008	1.835	1.543
28	2.008	2.102	1.811
32	2.087	2.366	2.028
36	2.106	2.610	2.283
40	2.126	2.850	2.539

Millimeters

Shell Size	L Max.	Q Max.	KK Max.
10SL	36.0	22.8	20.0
14S	36.5	29.2	24.0
16S	36.5	32.0	26.0
16	49.0	32.0	26.0
18	49.0	36.5	29.5
20	50.0	39.9	33.0
22	50.0	43.1	36.0
24	51.0	46.6	40.0
28	51.0	53.4	46.0
32	53.0	60.1	51.5
36	53.5	66.3	58.0
40	54.0	72.4	64.5

All dimensions for reference only.

GT08F for Bombardier

90° angle plug

- With a wire sealing grommet and cable clamp
- For use with individual wires
- Environment proof

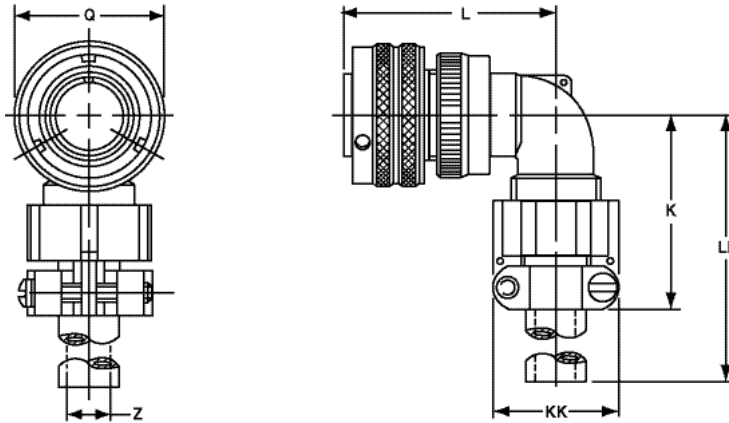

Inches

Shell Size	K Max.	L Max.	Q Max.	Z Max.	KK Max.	LL Max.
10SL	1.654	1.772	.898	.220	.894	3.937
14S	1.654	1.850	1.150	.312	1.083	3.937
16S	1.772	1.890	1.299	.437	1.181	3.937
16	1.772	2.244	1.299	.437	1.181	3.937
18	2.087	2.283	1.437	.562	1.299	3.937
20	2.087	2.402	1.571	.625	1.476	3.937
22	2.087	2.402	1.697	.625	1.476	3.937
24	2.283	2.598	1.835	.750	1.705	3.937
28	2.283	2.598	2.102	.750	1.705	3.937
32	2.598	2.835	2.366	.937	2.061	4.331
36	2.717	2.953	2.610	1.250	2.283	4.331
40	3.740	3.071	2.850	1.375	2.579	5.512

Millimeters

Shell Size	K Max.	L Max.	Q Max.	Z Max.	KK Max.	LL Max.
10SL	42	45	22.8	5.58	22.7	100
14S	42	47	29.2	7.92	27.5	100
16S	45	48	33.0	11.09	30.0	100
16	45	57	33.0	11.09	30.0	100
18	53	58	36.5	14.27	33.0	100
20	53	61	39.9	15.87	37.5	100
22	53	61	43.1	15.87	37.5	100
24	58	66	46.6	19.05	43.3	100
28	58	66	53.4	19.05	43.3	100
32	66	72	60.1	23.79	51.7	110
36	69	75	66.3	31.75	58.0	110
40	95	78	72.4	34.92	65.5	140

All dimensions for reference only.

GT08CFZ for Bombardier

90° angle plug

- With a wire sealing grommet
- Includes clamp to grip and seal jacketed cable
- Environment proof

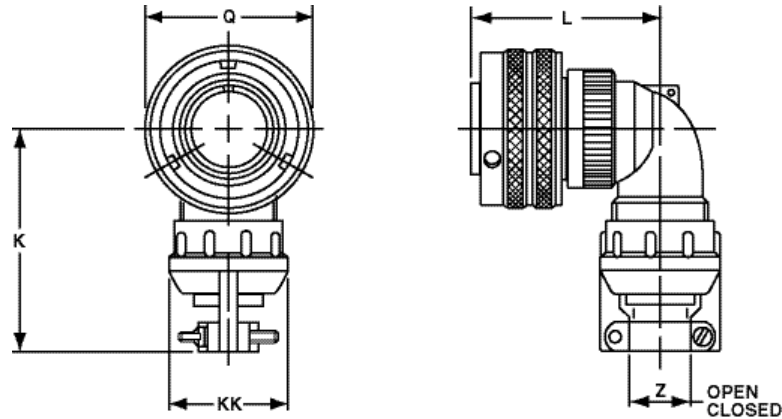

Inches

Shell Size*	K Max.	L Max.	Q Dia.	Z		KK ± .008
				Open	Closed	
10SL	2.402	1.772	.898	.312	.094	.890
18	2.677	2.283	1.437	.625	.378	1.220
20	2.677	2.402	1.571	.748	.445	1.469
22	2.677	2.402	1.697	.748	.445	1.469
24	2.992	2.598	1.835	.937	.610	1.654
28	2.992	2.598	2.102	.937	.610	1.654
32	3.425	2.835	2.366	1.250	.921	2.126
36	3.858	2.953	2.610	1.378	.921	2.248
40	4.055	3.071	2.850	1.624	1.177	2.500

Millimeters

Shell Size*	K Max.	L Max.	Q Dia.	Z		KK ± 0.2
				Open	Closed	
10SL	61	45	22.8	7.93	2.38	22.6
18	68	58	36.5	15.87	9.60	31.0
20	68	61	39.9	19.00	11.30	37.3
22	68	61	43.1	19.00	11.30	37.3
24	76	66	46.6	23.80	15.50	42.0
28	76	66	53.4	23.80	15.50	42.0
32	87	72	60.1	31.75	23.40	54.0
36	98	75	66.3	35.00	23.40	57.1
40	103	78	72.4	41.25	29.90	63.5

All dimensions for reference only.

* 14S, 16S and 16 shell sizes are available upon request.

GT Connector accessories for Bombardier 10-40450, 10-36675, 10-580649 sealing gaskets

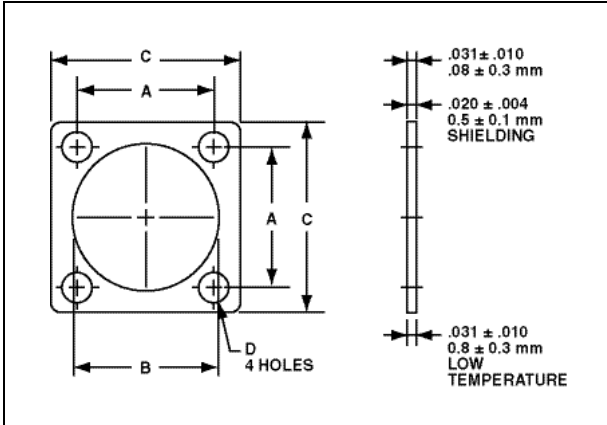

PLAIN FLAT GASKET

The Amphenol® plain flat gasket of synthetic rubber material is provided to take complete advantage of waterproof and pressure sealing features. It is for use with the flange mounted receptacle.

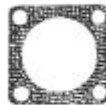

SHIELDING GASKET

This flat gasket is provided to give the maximum in connector performance. Its special feature is in providing the maximum radio shielding under difficult conditions of high receiver sensitivity and low signal strength while retaining the sealing characteristics of the plain gasket. This gasket is for use with the flange mounting receptacle.



LOW TEMPERATURE GASKET

This gasket is provided for applications where the major requirement is resistance to the injurious effects of extremely low temperature. Even at temperatures as low as -67°F this gasket retains its resiliency and will seal a pressure differential of 30 psi.

Additional versions of gaskets are available including low smoke zero halogen, and also high temperature and conductive types. Consult Amphenol Industrial Operations, Sidney NY, for further information.

Installation Dimensions					
MS Shell Size	A $\pm .010$	Front Panel Versions B + .016 - .000	Rear Panel Version B + .016 - .000	C + .016 - .000	D $\pm .010$
10SL	.719	.625	.724	1.000	.172
14S	.906	.875	.976	1.188	.172
16S	.969	1.000	1.087	1.281	.172
16	.969	1.000	1.087	1.281	.172
18	1.063	1.125	1.220	1.375	.203
20	1.156	1.250	1.354	1.500	.203
22	1.250	1.375	1.480	1.625	.203
24	1.375	1.500	1.618	1.750	.203
28	1.563	1.750	1.846	2.000	.203
32	1.750	2.000	2.110	2.250	.219
36	1.938	2.188	2.354	2.500	.219
40	2.188	2.438	2.587	2.750	.219

Order Data for Front Panel Mount Gaskets			
Front Panel Plain Version	Front Panel Shielding Version	Front Panel Low Temperature Version	Front Panel Low Smoke ZH Version
10-40450-10	10-40450-10S	10-36675-10	LS-40450-10
10-40450-14	10-40450-14S	10-36675-14	LS-40450-14
10-40450-16	10-40450-16S	10-36675-16	LS-40450-16
10-40450-18	10-40450-18S	10-36675-18	LS-40450-18
10-40450-20	10-40450-20S	10-36675-20	LS-40450-20
10-40450-22	10-40450-22S	10-36675-22	LS-40450-22
10-40450-24	10-40450-24S	10-36675-24	LS-40450-24
10-40450-28	10-40450-28S	10-36675-28	LS-40450-26
10-40450-32	10-40450-32S	10-36675-32	LS-40450-32
10-40450-36	10-40450-36S	10-36675-36	LS-40450-36
10-40450-40	10-40450-40S	10-36675-40	LS-40450-40

Installation Dimensions					
MS Shell Size	A ± 0.2	Front Panel Versions B + 0.4 - 0.0	Rear Panel Version B + 0.4 - 0.0	C + 0.4 - 0.0	D ± 0.2
10SL	18.2	15.9	18.4	25.4	4.36
14S	23.0	22.2	24.8	30.2	4.36
16S	24.6	25.4	27.6	32.5	4.36
16	24.6	25.4	27.6	32.5	4.36
18	27.0	28.57	31.0	35.0	5.15
20	29.4	31.75	34.4	38.1	5.15
22	31.8	34.9	37.6	41.2	5.15
24	34.9	38.1	41.1	44.5	5.15
28	39.7	44.45	46.9	50.8	5.15
32	44.5	50.8	53.6	57.2	5.56
36	49.2	55.57	59.8	63.5	5.56
40	55.6	61.92	65.7	69.9	5.56

Order Data for Rear Panel Mount Gaskets	
Rear Panel Plain Version	Rear Panel Low Smoke ZH Version
10-580649-11	LS-580649-11
10-580649-14	LS-580649-14
10-580649-16	LS-580649-16
10-580649-18	LS-580649-18
10-580649-20	LS-580649-20
10-580649-22	LS-580649-22
10-580649-24	LS-580649-24
10-580649-26	LS-580649-26
10-580649-32	LS-580649-32
10-580649-36	LS-580649-36
10-580649-40	LS-580649-40

GT Connector accessories for Bombardier receptacle protection caps

- Protective metal caps which seal the front of receptacles
- Includes a chain for retention of the cap at the required location

* 10-580902-XXY

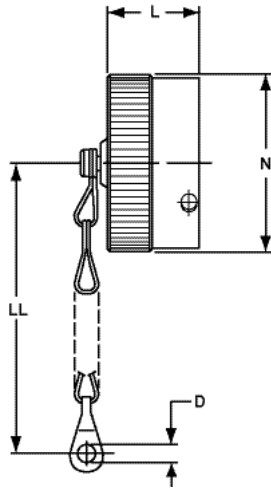

* To complete order number, add shell size and suffix number. For example, shell size 11 with black zinc cobalt plate would be 10-580902-11Y.

Inches

Shell Size	D + .020 - .000	L Max.	N Max.	LL Approx.
11	.173	.700	.905	5.000
14	.173	.700	1.181	5.000
16	.173	.700	1.280	5.000
17	.173	.900	1.280	5.000
18	.173	.900	1.457	5.000
20	.173	.900	1.594	5.000
22	.173	.900	1.713	5.000
24	.173	.900	1.850	5.000
28	.220	.900	2.126	7.480
32	.261	.900	2.382	7.480
36	.261	.900	2.638	7.480
40	.261	.900	2.874	7.480

Millimeters

Shell Size	D + 0.5 - 0.0	L Max.	N Max.	LL Approx.
11	4.4	17.8	23.0	127
14	4.4	17.8	30.0	127
16	4.4	17.8	32.5	127
17	4.4	22.9	32.5	127
18	4.4	22.9	37.0	127
20	4.4	22.9	40.5	127
22	4.4	22.9	43.5	127
24	4.4	22.9	47.0	127
28	5.6	22.9	54.0	190
32	5.6	22.9	60.5	190
36	5.6	22.9	67.0	175
40	5.6	22.9	73.0	190

All dimensions for reference only.

GT Connector accessories for Bombardier plug protection caps

- Protective metal caps which seal the front of plugs
- Includes a chain for retention of the cap at the required location

* 10-580903-XXY

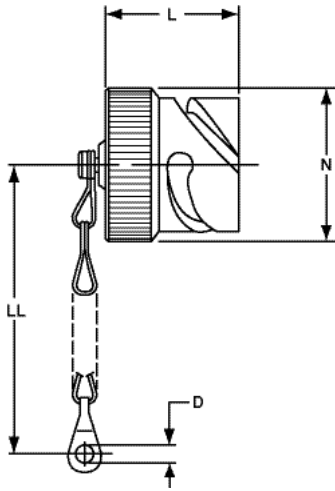

* To complete order number, add shell size and suffix number. For example, shell size 11 with black zinc cobalt plate would be 10-580903-11Y.

Inches

Shell Size	D + .020 - .000	L Max.	N Max.	LL Approx.
11	.157	.945	.807	5.000
14	.157	.945	1.059	5.000
16	.157	.945	1.169	5.000
17	.157	.945	1.169	5.000
18	.157	.945	1.303	5.000
20	.189	1.260	1.437	5.520
22	.189	1.260	1.563	5.520
24	.189	1.260	1.701	5.520
28	.220	1.260	1.929	7.480
32	.261	1.260	2.193	7.480
36	.261	1.260	2.437	7.480
40	.261	1.260	2.665	7.480

Millimeters

Shell Size	D + 0.5 - 0.0	L Max.	N Max.	LL Approx.
11	4.0	24	20.5	127
14	4.0	24	26.9	127
16	4.0	24	29.7	127
17	4.0	24	29.7	127
18	4.0	24	33.1	127
20	4.8	32	36.5	140
22	4.8	32	39.7	140
24	4.8	32	43.2	140
28	4.8	32	49.0	190
32	5.6	32	55.7	190
36	5.6	32	61.9	190
40	5.6	32	67.7	190

All dimensions for reference only.

GT accessories for Bombardier

rear mounting data, panel cut-out dimensions, sealing plugs, sealing ranges, backshell torque forces

REAR MOUNTING DATA MAXIMUM PANEL THICKNESS

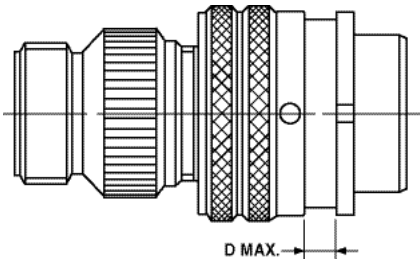

Size	Dimension D	
	GT030	
	Inches	(mm)
10SL	.303	7.70
14S	.303	7.70
16S	.303	7.70
16	.242	6.15
18	.303	7.70
20	.303	7.70
22	.303	7.70
24	.303	7.70
28	.343	8.70
32	.309	7.85
36	.309	7.85
40	.309	7.85

GROMMET HOLE SEALING RANGES

Hole Size	Sealing Range	
	(mm)	Inches
16	2.3 – 3.0	.090 – .118
12	3.2 – 4.5	.126 – .177
8	3.8 – 6.5	.150 – .256
4	7.1 – 9.3	.279 – .366
0	10.0 – 13.7	.394 – .539

RECOMMENDED TORQUE FORCES CONNECTOR BACKSHELLS

Size	In./Lb. Max.
10SL	26
14S	44
16	50
16S	50
18	55
20	65
22	85
24	90
28	114
32	120
36	153
40	170

SEALING PLUG 10-405996-XX

Sealing plugs are used to fill unused holes in multi-holed grommet configurations.

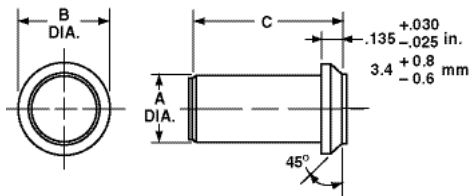

Order No.	Contact Size	Wire Size	Color Code	Inches		
				A Dia. ±.010	B ±.005	C ±.010
10-405996-16	16	20-16	Blue	.083	.133	.564**
10-405996-12	12	14-12	Yellow	.121	.171	.564**
10-405996-8	8	10-8	Red	.185	.315	.470
10-405996-4	4	4-6	Blue	.310	.415	.470
10-405996-0	0	0-2	Yellow	.440	.605	1.000

Millimeters		
A Dia. ± 0.2	B ± 0.1	C ± 0.2
2.1	3.4	14.3***
3.1	4.3	14.3***
4.7	8.0	11.9
7.9	10.5	11.9
11.2	15.4	25.4

** ± .020 (in.) *** ± 0.5 (mm)

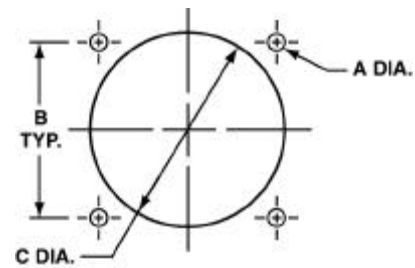

PANEL CUT-OUT DIMENSIONS

Shell Size	A Dia. Hole Size	Connector Styles	
		030	Rear Mount 030
		B ±.004	C Dia.
10SL	.126	.717	1 3/4
14S	.126	.906	1
16S/16	.126	.969	1 1/8
18	.126	1.063	1 1/4
20	.126	1.157	1 3/8
22	.126	1.252	1 1/2
24	.146	1.374	1 5/8
28	.146	1.563	1 7/8
32	.169	1.752	2 1/8
36	.169	1.937	2 3/8
40	.169	2.185	2 5/8

All dimensions for reference only.

GT Connectors

crimp contacts and application tools

Machined from copper alloys and silver-plated for maximum corrosion resistance, with a minimum millivolt drop and a maximum current carrying capacity, the size 16 and 12 socket contacts are of the closed entry design. Crimp contacts are available for all MS insert arrangements and are identified with an Amphenol® proprietary number.

CRIMP CONTACTS

CRIMP CONTACT DATA				APPLICATION TOOLS										
PART NUMBER				MATING SIZE	WIRE WELL SUFFIX	Crimp Tools	Positioner/ Die Set	Locator/ Color						
PIN CONTACT		SOCKET CONTACT (split leaf)												
SILVER	GOLD("D")	SILVER	GOLD("D")											
10-40553	10-597160-15D	10-597109-161	10-597109-16D	16S	16-18-20	Daniels AF8 or Equivalent	TH29-1 or Equivalent	Red						
10-606014-40	10-597160-40D	10-597109-401	10-597109-40D		12-14									
10-606014-221	10-597160-19D	10-597109-191	10-597109-19D		14-16									
10-606014-291	10-597160-34D	10-597109-341	10-597109-34D		20-22									
10-606014-46	10-597160-46D	10-597109-461	10-597109-46D		20-24									
10-40557	10-597160-16D	10-597109-171	10-597109-17D	16	16-18-20			Daniels AF8 or Equivalent	TH29-1 or Equivalent	Pin - Blue Socket - Green				
10-606014-022	10-597160-22D	10-597109-221	10-597109-22D		12-14									
10-606014-171	10-597160-17D	10-597109-141	10-597109-14D		14-16									
10-606014-311	10-597160-33D	10-597109-331	10-597109-33D		20-22									
10-606014-361	10-597160-36D	10-597109-361	10-597109-36D		20-24									
10-606014-391	10-597160-39D	10-597109-391	10-597109-39D	24-26	12					Daniels AF8 or Equivalent	TH29-1 or Equivalent	Green		
10-606014-43	10-597160-43D	10-597109-431	10-597109-43D	20-26										
10-606014-121	10-597160-12D	10-597109-131	10-597109-13D	12-14										
10-606014-231	10-597160-23D	10-597109-231	10-597109-23D	8-10										
10-606014-251	10-597160-26D	10-597109-261	10-597109-26D	10-12										
10-606014-271	10-597160-27D	10-597109-271	10-597109-27D	14-16-18										
10-606014-261	10-597160-24D	10-597109-241	10-597109-24D	18-20										
10-606014-201	10-597160-20D	10-597109-201	10-597109-20D	20-22										
10-40792	10-597160-8D	10-40793	10-597109-8D	8	8	Pico 400BHD	Pico 414DA-8N					Pico Pin - 4025 Socket - 4026		
10-606014-41	10-597160-41D	10-597109-411	10-597109-41D		6									
10-606014-321	10-597160-28D	10-606015-321	10-597109-28D		10-12									
10-606014-381	10-597160-38D	10-597109-381	10-597109-38D		12-14									
10-40564	10-597160-4D	10-40565	10-597109-4D	4	4							Pico 400BHD	Pico 414DA-4N	Pico 4043
10-606014-58	10-597160-58D	10-597109-581	10-597109-58D		6									
10-606014-331	10-597160-35D	10-597109-351	10-597109-35D		8									
10-606014-44	10-597160-44D	10-606015-441	10-597109-44D		10									
10-606014-45	10-597160-45D	10-597109-451	10-597109-45D		16									
10-581806-000	10-597160-1D	10-581808-000	10-597159-1D	0	0			Pico 400BHD	Pico 414DA-0N					Pico Pin - 4042-1 Socket - 4042
10-606014-341	10-597160-29D	10-597109-291	10-597109-29D		0-2									
10-606014-351	10-597160-30D	10-606015-351	10-597109-30D		4									
10-597276-48	10-597276-48D	10-606015-48	10-597109-48D	2/0	2/0					Pico 500	Pico 514DA2/ 0N			Pico Pin - 6490 Socket - 6491
10-597276-47	10-597276-47D	10-606015-47	10-597109-47D	4/0	4/0						Pico 514DA4/ 0N			

GT Connectors

crimp contacts, cont.

CRIMP CONTACTS

Mating Size	Wire Barrel Size	Allowable Wire Size	Test Current** Amps
16 Short	16	16	13
		18	10
		20	7.5
		22	5
16 Long	16	16	13
		18	10
		20	7.5
		22	5
12	12	12 14	23 17
8	8	8 10	46 33
4	4	4 6	80 60
0	0	0 2	150 125

** Contact ratings as stated are test ratings only. The connector may not withstand full rated current through all contacts continuously. Please note that the electrical data given is not an establishment of electrical safety factors. This is left entirely in the designer's hands as he can best determine which peak voltage, switching surges, transients, etc. can be expected in a particular circuit.

Table I
MIL-SPEC CONTACT ARRANGEMENT SERVICE RATING

MS Service Rating	Recommended Operating Voltage* at Sea Level		Effective Creepage Distance Nom.	Mechanical Spacing Nom.
	DC	AC (RMS)		
Inst.	250	200	1/16	
A	700	500	1/8	1/16
D	1250	900	3/16	1/8
E	1750	1250	1/4	3/16
B	2450	1750	5/16	1/4
C	4200	3000	1	5/16

* The values listed in Table I represent operating values which include a generous safety factor. It may be necessary for some applications to exceed the operating voltages listed here. If this is necessary, designers will find Table II useful for determining the degree to which the recommended values of Table I can be exceeded.

Table II
ALTITUDE VOLTAGE DERATING CHART**

MS Service Rating	Nominal Distance		Standard Sea Level Conditions		Pressure Altitude † 50,000 Feet		Pressure Altitude † 70,000 Feet	
	Airspace	Creepage	Minimum Flashover Voltage AC (RMS)	Test Voltage AC (RMS)	Minimum Flashover Voltage AC (RMS)	Test Voltage AC (RMS)	Minimum Flashover Voltage AC (RMS)	Test Voltage AC (RMS)
Inst.	1/32	1/16	1400	1000	550	400	325	260
A	1/16	1/8	2800	2000	800	600	450	360
D	1/8	3/16	3600	2800	900	675	500	400
E	3/16	1/4	4500	3500	1000	750	550	440
B	1/4	5/16	5700	4500	1100	825	600	480
C	5/16	1	8500	7000	1300	975	700	560

† Not corrected for changes in density due to variations in temperature

** No attempt has been made to recommend operating voltages. The designer must determine his own operating voltage by the application of a safety factor to the above derating chart to compensate for circuit transients, surges, etc.

X-ON Electronics

Largest Supplier of Electrical and Electronic Components

Click to view similar products for [Circular MIL Spec Contacts](#) category:

Click to view products by [Amphenol](#) manufacturer:

Other Similar products are found below :

[006-0984-20](#) [006-1186-20](#) [601101N004](#) [CT0E20-22SS](#) [CT1N20-23SS](#) [CT2-36-10PCAU](#) [CT6F36-10PCA152](#) [M39029/106-616](#) [M39029/18-179](#) [M39029/30-222](#) [M39029/31-235](#) [M39029/48-318](#) [M39029/73-397](#) [M39029/9-133](#) [M39029/9-134](#) [M5000-054-0020L](#) [M5100-057-2162](#) [809-023](#) [809-111](#) [811393-000](#) [850-014](#) [FRCIR01-20-4S-F80-VO](#) [900062-6-8L](#) [97-45-1418P-5\(920\)](#) [97-45-1418S-4](#) [97-45-1622P-5](#) [97-45-1622S-4\(920\)](#) [97-45-1622S-5](#) [97-55-1622S-5](#) [D-602-0104CS076](#) [D-602-0106CS076](#) [AIC12-10P](#) [AIC12-12SG](#) [AIC12-14P](#) [AIC16-16PG](#) [AIC16-2024SG](#) [AIC16S-16PG](#) [AIC8-12P](#) [AIC8-12S](#) [AIC8-8SG](#) [AIC8-8SRAD](#) [1495044-1](#) [BA-4016-50LD](#) [162GB-149-20000-05](#) [BACC47CP2T](#) [BACC47DP4](#) [BACC47GC1A](#) [BACC47GN1](#) [173-900245-91](#) [CA02R28-12PA152F80](#)