

REV. E	SHEET 1 OF 2	DOCUMENT NO. 10-597536
REVISIONS		
LTR	DESCRIPTION	DATE
A-D	SEE RECORD DWGS	3/11/96
E	(CL 11) ADDED -17 THRU -33 ECN: B5159-0000	12/4/13

DOCUMENT NO. 10-597536

SHEET 1 OF 2

REV. E

C

B

A

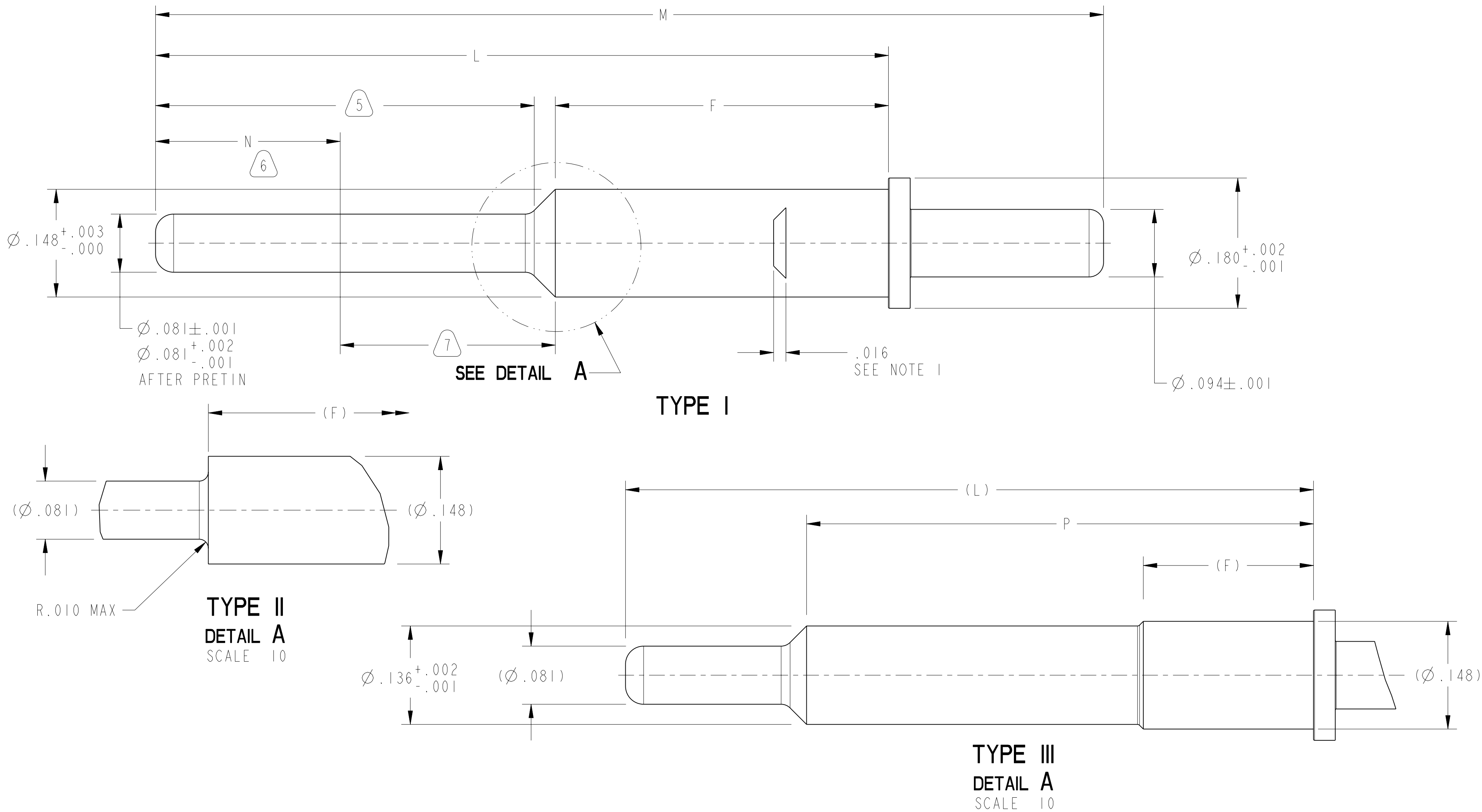

NOTES: SEE SHEET 2

THE USE OF THIS DOCUMENT IS UNLIMITED. HOWEVER, DOCUMENTS REFERENCED HEREON MAY CONTAIN LIMITED RIGHTS DATA.

N/A
NEXT ASSEMBLY

PRO/ENGINEER INFORMATION
 Pro/e Model Used:
 10-597536.TYPE.1.ASSEM
 Drawing Name:
 10-597536

UNLESS OTHERWISE SPECIFIED	SPECIFICATIONS	POS	QTY	PART NUMBER	DESCRIPTION	NOTE
LINEAR DIMENSIONS ARE IN INCHES TOLERANCES: .XXXX = ±.0005 ANGLES= ±2° .XXX = ±.010 .XX = ±.03 .X = ±.1 DIM. & TOL. PER ASME Y14.5M; DRM PER MIL-DTL-31000; OTHER Amphenol Stds. PER 9-3800 LEGENDS: =FLAG NOTE CALL OUT REFERENCE ONLY	MATERIAL SPEC.	PARTS LIST				
	N/A	AMPHENOL CORPORATION 40-60 DELAWARE AVENUE SIDNEY, N.Y. 13858 CONTACT, PIN, SIZE 12, PCB TYPE, JT/LJT-R				
PROCESS SPEC.	SEE NOTES 3 & 4	APPROVALS		DATE	PREPARED BY: K.O.DAVIS III ENGINEER IN CHARGE: LRATCHFORD DESIGN MANAGER: ADAVIS DESIGN ACTIVITY GROUP: MIL AERO 11-Mar-96 THIRD ANGLE PROJECTION	
				SIZE C	CAGE CODE 77820	DOCUMENT NO. 10-597536 SCALE: 10.0 REF. 10-597502-1 SHEET 1 OF 2

DOCUMENT NO. 10-597536

SHEET 1 OF 2

REV. E

VERSION 0
REVISION E
Eng PDM Information For Reference Only

SHEET 1 OF 2

DOCUMENT NO. 10-597536

10-597536

SHEET 2 OF 2

REV. E

C

B

A

PART NUMBER	MADE FROM	F	L	M REF	P	MEAN SURFACE AREA SQ. IN.	TYPE	N MIN
10-597536-01()	10-597502-01B	.230±.005	.753±.005	1.050		.3842	I	.200
10-597536-02()	10-597502-02B	.230±.005	.873±.005	1.170		.4147	I	.200
10-597536-03()	10-597502-03B	.230±.005	.585±.005	.882		.3414	I	.200
10-597536-04()	10-597502-04B	.460+.000/- .015	.873±.005	1.170	—	.4631	I	.383
10-597536-05()	10-597502-05B	.460+.000/- .015	.783±.005	1.080		.4402	I	.293
10-597536-06()	10-597502-06B	.460+.000/- .015	1.012±.003	1.309		.4897	I	.500
10-597536-07()	10-597502-07B	.718±.005	.975±.005	1.271		.5384	II	.175
10-597536-08()	10-597502-08B	.235±.005	.950±.005	1.247	.700	.5059	III	.175
10-597536-09()	10-597502-09B	.470±.005	.873±.005	1.170	—	.4543	II	.330
10-597536-10()	10-597502-10B	.460+.000/- .015	.739±.005	1.036	—	.4211	I	.200
10-597536-11()	10-597502-11B	.460+.000/- .015	.650±.005	.947	—	.3985	I	.130
10-597536-12()	10-597502-12B	.285+.000/- .015	1.710±.005	2.007	—	.6309	II	1.300
10-597536-13()	10-597502-13B	.328+.000/- .015	1.010±.005	1.307	—	.4798	I	.580
10-597536-14()	10-597502-14B	.230±.005	1.142±.005	1.439	—	.4750	I	.800
10-597536-15()	10-597502-15B	.230±.005	.825±.005	1.122	—	.3965	II	.520
10-597536-16()	10-597502-16B	.230±.005	.680±.005	.997	—	.3567	I	.375
10-597536-17()	10-597502-17B	1.000±.005	1.738±.005	2.035	—	.7893	I	.650
10-597536-18()	10-597502-18B	.230±.005	.773±.003	1.070	—	.3802	I	.475
10-597536-19()	10-597502-19B	.230±.005	.938±.003	1.235	—	.4223	I	.640
10-597536-20()	10-597502-20B	.230±.005	.563±.005	.860	—	.3277	I	.265
10-597536-21()	TBD							
10-597536-22()	10-597502-22B	.525+.000/- .005	.731±.003	1.028	—	.3633	II	.135
10-597536-23()	10-597502-23B	.680±.005	1.035±.005	1.332	—	.5281	I	.355
10-597536-24()	10-597502-24B	.525+.000/- .005	.938±.003	1.235	—	.4858	II	.345
10-597536-25()	10-597502-25B	.275+.000/- .015	.400±.003	.697	—	.2963	I	.070
10-597536-26()	10-597502-26B	.460+.000/- .015	.965±.003	1.262	—	.4787	I	.435
10-597536-27()	10-597502-27B	.460+.000/- .015	.805±.003	1.102	—	.4380	I	.275
10-597536-28()	10-597502-28B	.515±.003	.825±.005	1.122	—	.4543	II	.280
10-597536-29()	10-597502-29B	.460+.000/- .015	.985±.003	1.282	—	.4835	I	.455
10-597536-30()	10-597502-30B	.460+.000/- .015	1.081±.005	1.378	—	.5079	I	.575
10-597536-31()	10-597502-31B	.460+.000/- .015	.898±.005	1.195	—	.4615	I	.370
10-597536-32()	10-597502-32B	.460+.000/- .015	.850±.005	1.147	—	.4496	I	.320
10-597536-33()	10-597502-33B	.230±.005	.460±.003	.757	—	.3007	I	.170

4

8

2. DIMENSIONS ARE AFTER PLATING.

1. TRADEMARK, 9-6700 TYPE IV, MUST BE BLACK INK STAMPED PER 9-7530 IN APPROXIMATE AREA SHOWN AFTER PLATING. IF NOT PREVIOUSLY METAL STAMPED. DIRECTION IS OPTIONAL. TRADE MARK MAY BE SOLID. NO DISTORTION OF CONTACT IS PERMITTED.

NOTES:

THE USE OF THIS DOCUMENT IS UNLIMITED. HOWEVER, DOCUMENTS REFERENCED HEREON MAY CONTAIN LIMITED RIGHTS DATA.

8. "L" DIMENSION IS AFTER PLATING. "L" DIMENSION AFTER PRETINNING MAY EXCEED DIMENSION SHOWN BY .010 MAXIMUM, DUE TO SOLDER BUILD-UP ON PCB TAIL TIP.

7. SOLDER ON INDICATED AREA PERMISSIBLE.

6. PRETIN INDICATED LENGTH PER 9-7894, AFTER PLATING.

5. INDICATED AREA SHALL BE CAPABLE OF MEETING THE SOLDERABILITY REQUIREMENTS OF 9-8825 AFTER STEAM AGING.

4. TO COMPLETE, ADD APPROPRIATE SUFFIX DIGIT FOR FINISH:

SUFFIX	FINISH DATA
5	GOLD PLATE PER 9-6800-5

3. PROCESS SPEC:
TEST 9-5272-16
9-7894, 9-7530, 9-6700, 9-8825, 9-6800

FORMAT: C-U-E-1

10-597536

SHEET 2 OF 2

REV. E

SIZE C	CAGE CODE 77820	DOCUMENT NO. 10-597536	REV. E
SCALE: 3.0		REF: 10-597502-1	SHEET 2 OF 2

10-597536 SHEET 2 OF 2 REV. E

X-ON Electronics

Largest Supplier of Electrical and Electronic Components

Click to view similar products for [Circular MIL Spec Contacts](#) category:

Click to view products by [Amphenol](#) manufacturer:

Other Similar products are found below :

[006-0984-20](#) [006-1186-20](#) [601101N004](#) [CT0E20-22SS](#) [CT1N20-23SS](#) [CT2-36-10PCAU](#) [CT6F36-10PCA152](#) [M39029/106-616](#) [M39029/18-179](#) [M39029/30-222](#) [M39029/31-235](#) [M39029/48-318](#) [M39029/73-397](#) [M39029/9-133](#) [M39029/9-134](#) [M5000-054-0020L](#) [M5100-057-2162](#) [809-023](#) [809-111](#) [811393-000](#) [850-014](#) [FRCIR01-20-4S-F80-VO](#) [900062-6-8L](#) [97-45-1418P-5\(920\)](#) [97-45-1418S-4](#) [97-45-1622P-5](#) [97-45-1622S-4\(920\)](#) [97-45-1622S-5](#) [97-55-1622S-5](#) [D-602-0104CS076](#) [D-602-0106CS076](#) [AIC12-10P](#) [AIC12-12SG](#) [AIC12-14P](#) [AIC16-16PG](#) [AIC16-2024SG](#) [AIC16S-16PG](#) [AIC8-12P](#) [AIC8-12S](#) [AIC8-8SG](#) [AIC8-8SRAD](#) [1495044-1](#) [BA-4016-50LD](#) [162GB-149-20000-05](#) [BACC47CP2T](#) [BACC47DP4](#) [BACC47GC1A](#) [BACC47GN1](#) [173-900245-91](#) [CA02R28-12PA152F80](#)