

# Fixed Wirewound High Power Vitreous Resistors with Terminal Collars or Bands



The RW wirewound power resistors are extremely well suited to professional applications, where high power and excellent endurance are required. They meet all requirements of NF C 93-214 specifications and five sizes cover the power range from 10 W to 80 W. Non inductive types are available, by using the special RWNI winding. For higher power or extremely severe conditions of use, see the RWST series.

NF F 16101, 10/1988 and 16102, 04/1992: Not applicable (our parts are made of metallic and refractory materials).  
NF C 93-214. Performances according to NF C 93-214.

## FEATURES

- 10 W to 80 W at 25 °C
- NF C 93-214
- RB 13 x 70 RB 20 x 117
- High power up to 80 W at 25 °C
- High long term stability drift < 2.5 % after 5000 h
- Great mechanical strength
- Fire proof
- Environmental performance
- Thermal shock strength 0.5 % (100 % h at -25 °C)
- Material categorization: for definitions of compliance please see [www.vishay.com/doc?99912](http://www.vishay.com/doc?99912)



**RoHS**  
COMPLIANT

## DIMENSIONS in millimeters

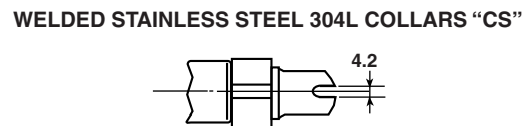
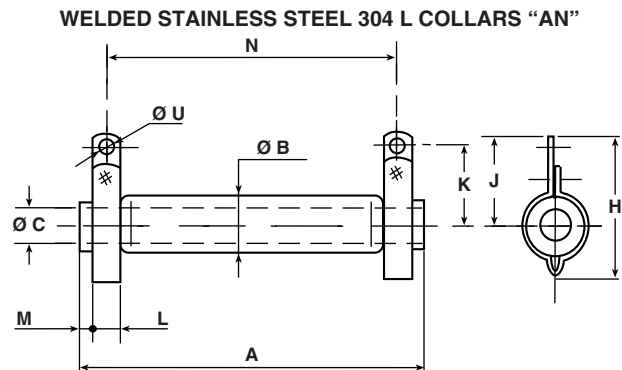
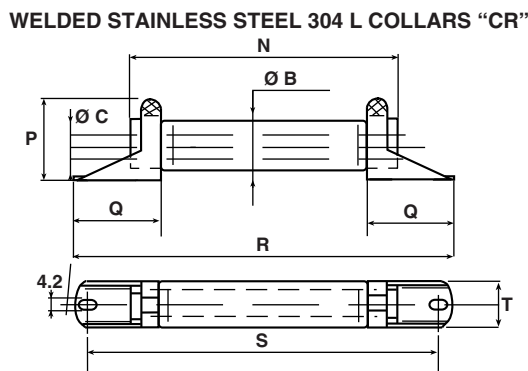
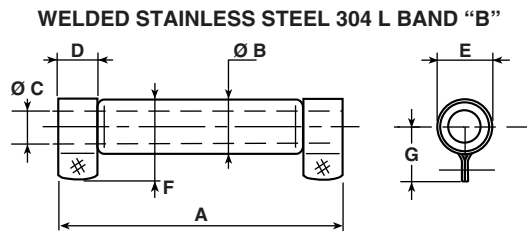

SERIES	CONNECTIONS				A ± 2	Ø B MAX.	Ø C MIN.	D + 0.5 + 0	E	F MAX.	G	H	J	K
	COLLAR	COLLAR	COLLAR	BAND										
RW 8 x 34	AN	-	-	-	34	11.5	4.1	-	-	-	-	28 ± 1.0	19.5 ± 0.5	16 ± 0.5
RW 10 x 50	AN	CR	-	B	50	13	5	8	11 ± 0.5	21	14 ± 0.5	31 ± 1.0	22 ± 0.5	18 ± 0.5
RW 13 x 70	AN	CR	CS	B	70	16	5	10.5	14 ± 0.5	24.5	16 ± 0.5	34 ± 1.0	24 ± 0.5	20 ± 0.5
RW 16 x 94	AN	-	-	B	94	19.5	9	12	17 ± 0.5	28	18 ± 0.5	38 ± 1.0	25 ± 0.5	21 ± 0.5
RW 20 x 117	AN	-	-	B	117	23	9	14	21 ± 0.7	33	21 ± 0.7	42 ± 1.5	28 ± 0.7	24 ± 0.7



DIMENSIONS in millimeters													
SERIES	CONNECTIONS				L + 0.5 + 0	M ± 1.5	N ± 2	P ± 1	Q ± 0.5	R ± 2	S ± 2	T	Ø U
	COLLAR	COLLAR	COLLAR	BAND									
RW 8 x 34	AN	-	-	-	5	1	27	-	-	-	-	-	3.2
RW 10 x 50	AN	CR	-	B	6.35	1.5	40	19.5	19.5	72	62	12	4.2
RW 13 x 70	AN	CR	CS	B	0.6	3.5	56	22.5	20.5	91	81	15	4.2
RW 16 x 94	AN	-	-	B	0.6	4	78	-	-	-	-	-	4.2
RW 20 x 117	AN	-	-	B	0.8	6	98	-	-	-	-	-	4.2

STANDARD ELECTRICAL SPECIFICATIONS				
MODEL	SIZE	RESISTANCE RANGE Ω	RATED POWER $P_{25^{\circ}\text{C}}$ W	TOLERANCE ± %
RW 8 x 34	0834	1 to 10K	10	5
RW 10 x 50	1050	1 to 27K	17	5
RW 13 x 70	1370	2.2 to 56K	28	5
RW 16 x 94	1694	2.2 to 56K	44	5
RW 20 x 117	20117	2.7 to 68K	72	5

MECHANICAL SPECIFICATIONS	
Mechanical Protection	Enamel
Resistive Element	Ni-Cr wire
Connections	B band AN - CR - CS collars
Average Unit Weight	10 g to 100 g

ENVIRONMENTAL SPECIFICATIONS	
Temperature Range	-55 °C, +450 °C
Climatic Category	-55 °C / +200 °C / 56 days

TECHNICAL SPECIFICATIONS	
Resistance Range	1 Ω to 68 kΩ (E12 preferred series value)
Power Rating	10 W to 80 W at 25 °C
Temperature Coefficient	75 ppm/°C (typical)
Dielectric Strength	1000 V <sub>RMS</sub> (AN collars)
Insulation Resistance	100 MΩ (500 V <sub>DC</sub> ) AN collars
Shelf Life	0.1 % year (typical)

PERFORMANCE			
TESTS	CONDITIONS	REQUIREMENTS	TYPICAL VALUES AND DRIFTS
Short Time Overload	10 $P_r$ during 5 s voltage limited at < 5000 V current limited at 5 A	2 % or 0.05 Ω	0.5 %
Climatic Sequence	-55 °C, +200 °C 5 cycles	3 % or 0.05 Ω Insulation resistance > 100 MΩ	0.5 %
Humidity (Steady State)	56 days 95 % relative humidity	2 % or 0.05 Ω Insulation resistance > 100 MΩ	0.5 %
Thermal Shock	Load at 100 % $P_r$ followed by cold temp. exposure at -55 °C	2 % or 0.05 Ω	0.5 %
Shock	Severity 50, 9 shocks/each side	1 % or 0.05 Ω	0.25 %
Vibration	Severity 55B	1 % or 0.05 Ω	0.25 %
Terminal Strength	Collar AN traction 40 N band B torque 60 Ncm	1 % or 0.05 Ω	0.5 %
Load Life	90' / 30' cycle 1000 h at $P_r$ 25 °C	5 %	1000 h 1.5 %
			5000 h 2.5 %

SPECIAL FEATURES					
RW STYLE	8 x 34	10 x 50	13 x 70	16 x 94	20 x 117
Designation NF C 93-214	-	-	RB 13 x 70	-	RB 20 x 117
Maximum Power Rating at 25 °C	13 W	20 W	32 W	50 W	80 W
Ohmic Range (E12, E24 series)	1 Ω to 10 kΩ	1 Ω to 27 kΩ	2.2 Ω to 56 kΩ	2.2 Ω to 56 kΩ	2.7 Ω to 68 kΩ
Limiting Element Voltage	300 V	450 V	650 V	900 V	1100 V
Critical Resistance	6.9 kΩ	10 kΩ	13.2 kΩ	16 kΩ	15.1 kΩ



**NON INDUCTIVE WINDING**

For high frequencies, low self induction resistors are available with special windings. RWNI designation.

MODEL AND STYLE	RWNI 8 x 34	RWNI 10 x 50	RWNI 13 x 70	RWNI 16 x 94	RWNI 20 x 117
Ohmic Range	4.7 Ω 100 Ω	4.7 Ω 220 Ω	4.7 Ω 620 Ω	10 Ω 1.2 kΩ	10 Ω 2.2 kΩ

**POWER RATING**

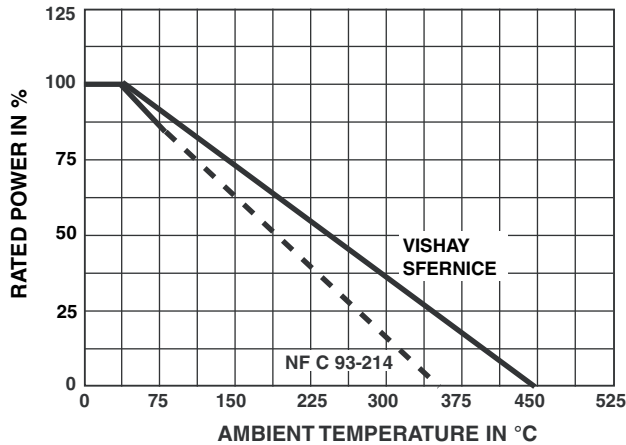

**TEMPERATURE RISE**

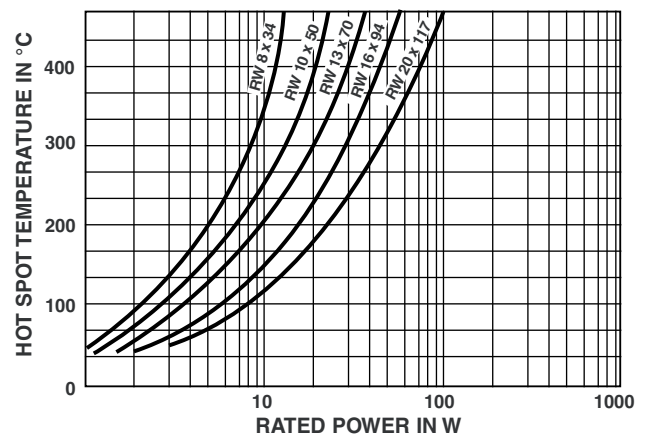

**MARKING**

Vishay Sfernice trademark, model, style, NF style (if applicable) nominal resistance (in Ω), tolerance (in %), manufacturing date.

ORDERING INFORMATION							
RW	20 x 117	NI	AN	68 Ω	± 5 %	B020	e
MODEL	STYLE	NON-INDUCTIVE WINDING Optional	SPECIAL DESIGN Optional	CONNECTIONS	OHMIC VALUE Custom items are subject to extra-charge and min. order. Please see price list.	TOLERANCE	PACKAGING LEAD (Pb)-FREE

GLOBAL PART NUMBER INFORMATION																		
R	W	1	6	X	9	4	A		2	0	3	J	B	0	0			
GLOBAL MODEL	SIZE	LEADS	OPTION	OHMIC VALUE				TOLERANCE	PACKAGING			SPECIAL						
RW	8 x 34 10 x 50 13 x 70 16 x 94 20 x 117	A = AN B = B C = CS D = CR	N = Non inductive winding	The first two digits are significant figures and the last digit specifies the number of zeros to follow. R designates decimal point. 203 = 20 kΩ 471 = 470 Ω 48R = 48.7 Ω R01 = 0.01 Ω				J = 5.0 %	Box: BA25 BA25NA BO20 BO20NA BO30 BO30NA BO40 BO40NA BO50 BO50NA			As applicable. Example: BC1						

RELATED DOCUMENTS	
APPLICATION NOTES	
Potentiometers and Trimmers	<a href="http://www.vishay.com/doc?51001">www.vishay.com/doc?51001</a>
Guidelines for Vishay Sfernice Resistive and Inductive Components	<a href="http://www.vishay.com/doc?52029">www.vishay.com/doc?52029</a>



## **Disclaimer**

ALL PRODUCT, PRODUCT SPECIFICATIONS AND DATA ARE SUBJECT TO CHANGE WITHOUT NOTICE TO IMPROVE RELIABILITY, FUNCTION OR DESIGN OR OTHERWISE.

Vishay Intertechnology, Inc., its affiliates, agents, and employees, and all persons acting on its or their behalf (collectively, "Vishay"), disclaim any and all liability for any errors, inaccuracies or incompleteness contained in any datasheet or in any other disclosure relating to any product.

Vishay makes no warranty, representation or guarantee regarding the suitability of the products for any particular purpose or the continuing production of any product. To the maximum extent permitted by applicable law, Vishay disclaims (i) any and all liability arising out of the application or use of any product, (ii) any and all liability, including without limitation special, consequential or incidental damages, and (iii) any and all implied warranties, including warranties of fitness for particular purpose, non-infringement and merchantability.

Statements regarding the suitability of products for certain types of applications are based on Vishay's knowledge of typical requirements that are often placed on Vishay products in generic applications. Such statements are not binding statements about the suitability of products for a particular application. It is the customer's responsibility to validate that a particular product with the properties described in the product specification is suitable for use in a particular application. Parameters provided in datasheets and / or specifications may vary in different applications and performance may vary over time. All operating parameters, including typical parameters, must be validated for each customer application by the customer's technical experts. Product specifications do not expand or otherwise modify Vishay's terms and conditions of purchase, including but not limited to the warranty expressed therein.

Except as expressly indicated in writing, Vishay products are not designed for use in medical, life-saving, or life-sustaining applications or for any other application in which the failure of the Vishay product could result in personal injury or death. Customers using or selling Vishay products not expressly indicated for use in such applications do so at their own risk. Please contact authorized Vishay personnel to obtain written terms and conditions regarding products designed for such applications.

No license, express or implied, by estoppel or otherwise, to any intellectual property rights is granted by this document or by any conduct of Vishay. Product names and markings noted herein may be trademarks of their respective owners.

## X-ON Electronics

Largest Supplier of Electrical and Electronic Components

*Click to view similar products for [Wirewound Resistors - Through Hole category](#):*

*Click to view products by [Vishay manufacturer](#):*

Other Similar products are found below :

[75822-2K4](#) [90J56R](#) [AC03000001208JAC00](#) [EP3WS47RJ](#) [C1010KJL](#) [C1015RJL](#) [C3A10KJT](#) [27J1K0](#) [ES3W47RJ](#) [AC04000001500JAC00](#)  
[AC10000002208JAB00](#) [AC10000004708JAB00](#) [SQMW5R39J](#) [SQPW5R22J](#) [SQPW5R33J](#) [1879927-3](#) [FCB2100RJ](#) [T505](#) [FSQ5WR47J](#)  
[FW10A33R0JA](#) [C1010RJL](#) [C10220RJL](#) [C10R47JL](#) [C141K0JL](#) [C144R7JL](#) [ES05W100RJ](#) [SQMW1047RJ](#) [SQMW210RJ](#) [ULW5-39R0JT075](#)  
[W31-R47JA1](#) [ULW5-68RJT075](#) [SQBW401K0JFASTON](#) [SPH1001JLF](#) [65888-3R3](#) [SQP500JB-400R](#) [SQBW403R3JFASTON](#) [280-PRM7-](#)  
[4.7-RC](#) [CW02B9R100JE73](#) [FW70A1000JA](#) [AC05000005608JAC00](#) [SQPW547RJ](#) [SQMW10R68J](#) [C102K2JL](#) [SQPW510RJ](#) [PW103001KLF](#)  
[SQPW522RJ](#) [SQPW568RJ](#) [FCB4560RJ](#) [FCB2R47J](#) [SQPW2R047J](#)