

REVISIONS

LTR	DESCRIPTION	DATE (YR-MO-DA)	APPROVED
A	Changes in accordance with NOR 5962-R111-96.	96-04-26	Michael A. Frye
B	Redraw with changes. Update to current requirements. Editorial changes throughout. - gap	06-08-01	Raymond Monnin

The original first page of this drawing has been replaced.

REV																			
SHEET																			
REV																			
SHEET																			

REV STATUS	REV	B	B	B	B	B	B	B	B	B	B	B	B	B	B		
OF SHEETS	SHEET	1	2	3	4	5	6	7	8	9	10	11	12				

PMIC N/A	PREPARED BY Tim H. Noh	<p align="center">DEFENSE SUPPLY CENTER COLUMBUS COLUMBUS, OHIO 43218-3990 http://www.dsccl.dla.mil</p>															
<p align="center">STANDARD MICROCIRCUIT DRAWING</p> <p align="center">THIS DRAWING IS AVAILABLE FOR USE BY ALL DEPARTMENTS AND AGENCIES OF THE DEPARTMENT OF DEFENSE</p> <p align="center">AMSC N/A</p>	CHECKED BY Tim H. Noh																
	APPROVED BY William K. Heckman	<p align="center">MICROCIRCUIT, DIGITAL, ECL, OR/NOR GATES, MONOLITHIC SILICON</p>															
	DRAWING APPROVAL DATE 91-02-05																
	REVISION LEVEL B		<table border="1"> <tr> <td>SIZE A</td> <td>CAGE CODE 67268</td> <td>5962-91528</td> </tr> </table>	SIZE A	CAGE CODE 67268	5962-91528											
SIZE A	CAGE CODE 67268	5962-91528															
		SHEET	1 OF 12														

1. SCOPE

1.1 Scope. This drawing documents two product assurance class levels consisting of high reliability (device classes Q and M) and space application (device class V). A choice of case outlines and lead finishes are available and are reflected in the Part or Identifying Number (PIN). When available, a choice of Radiation Hardness Assurance (RHA) levels are reflected in the PIN.

1.2 PIN. The PIN is as shown in the following example:

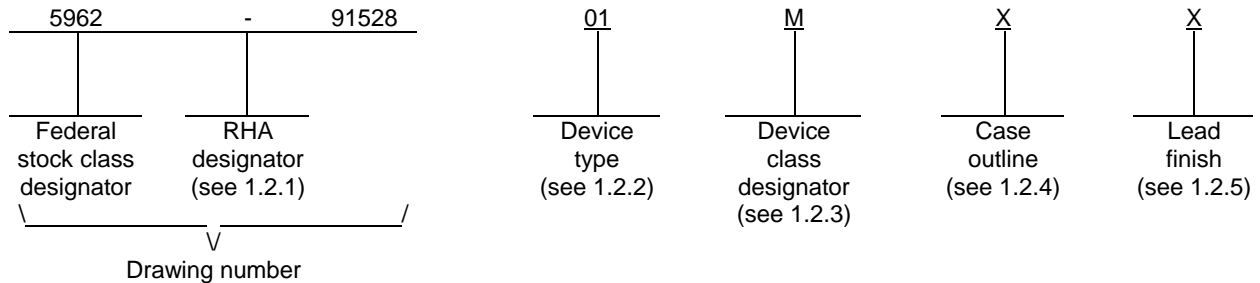

1.2.1 RHA designator. Device classes Q and V RHA marked devices meet the MIL-PRF-38535 specified RHA levels and are marked with the appropriate RHA designator. Device class M RHA marked devices meet the MIL-PRF-38535, appendix A specified RHA levels and are marked with the appropriate RHA designator. A dash (-) indicates a non-RHA device.

1.2.2 Device type(s). The device type(s) identify the circuit function as follows:

Device type	Generic number	Circuit function
01	100301	Triple 5-input OR/NOR gate
02	100302	Quint 2-input OR/NOR gate

1.2.3 Device class designator. The device class designator is a single letter identifying the product assurance level as follows:

Device class	Device requirements documentation
M	Vendor self-certification to the requirements for MIL-STD-883 compliant, non-JAN class level B microcircuits in accordance with MIL-PRF-38535, appendix A
Q or V	Certification and qualification to MIL-PRF-38535

1.2.4 Case outline(s). The case outline(s) are as designated in MIL-STD-1835 and as follows:

Outline letter	Descriptive designator	Terminals	Package style
X	GDIP5-T24 or CDIP6-T24	24	dual-in-line
Y	See figure 1	24	quad flat pack

1.2.5 Lead finish. The lead finish is as specified in MIL-PRF-38535 for device classes Q and V or MIL-PRF-38535, appendix A for device class M.

STANDARD MICROCIRCUIT DRAWING DEFENSE SUPPLY CENTER COLUMBUS COLUMBUS, OHIO 43218-3990	SIZE A		5962-91528
		REVISION LEVEL B	SHEET 2

1.3 Absolute maximum ratings. 1/

Negative supply voltage range (V_{EE})	-7.0 V dc to +0.5 V dc
DC input voltage range (V_{IN})	V_{EE} to +0.5 V
Maximum dc output current (I_{OUT})	-50 mA
Storage temperature range	-65°C to +150°C
Lead temperature (soldering, 10 seconds)	+300°C
Junction temperature (T_J)	+175°C
Maximum power dissipation (P_D):	
Device type 01	304 mW
Device type 02	453 mW
Thermal resistance, junction-to-case (θ_{JC}):	
Case X	See MIL-STD-1835
Case Y	28°C/W

1.4 Recommended operating conditions.

Negative supply voltage range (V_{EE})	-5.7 V minimum to -4.2 V maximum
Case operating temperature range (T_C)	-55°C to +125°C
High level input voltage range (V_{IH})	-1.165 V minimum to -0.870 V maximum
Low level input voltage range (V_{IL})	-1.830 V minimum to -1.475 V maximum

2. APPLICABLE DOCUMENTS

2.1 Government specification, standards, and handbooks. The following specification, standards, and handbooks form a part of this drawing to the extent specified herein. Unless otherwise specified, the issues of these documents are those cited in the solicitation or contract.

DEPARTMENT OF DEFENSE SPECIFICATION

MIL-PRF-38535 - Integrated Circuits, Manufacturing, General Specification for.

DEPARTMENT OF DEFENSE STANDARDS

MIL-STD-883 - Test Method Standard Microcircuits.
MIL-STD-1835 - Interface Standard Electronic Component Case Outlines.

DEPARTMENT OF DEFENSE HANDBOOKS

MIL-HDBK-103 - List of Standard Microcircuit Drawings.
MIL-HDBK-780 - Standard Microcircuit Drawings.

(Copies of these documents are available online at <http://assist.daps.dla.mil/quicksearch/> or www.dodssp.daps.mil or from the Standardization Document Order Desk, 700 Robbins Avenue, Building 4D, Philadelphia, PA 19111-5094.)

2.2 Order of precedence. In the event of a conflict between the text of this drawing and the references cited herein, the text of this drawing takes precedence. Nothing in this document, however, supersedes applicable laws and regulations unless a specific exemption has been obtained.

1/ Stresses above the absolute maximum rating may cause permanent damage to the device. Extended operation at the maximum levels may degrade performance and affect reliability.

STANDARD MICROCIRCUIT DRAWING DEFENSE SUPPLY CENTER COLUMBUS COLUMBUS, OHIO 43218-3990	SIZE A		5962-91528
		REVISION LEVEL B	SHEET 3

3. REQUIREMENTS

3.1 Item requirements. The individual item requirements for device classes Q and V shall be in accordance with MIL-PRF-38535 and as specified herein or as modified in the device manufacturer's Quality Management (QM) plan. The modification in the QM plan shall not affect the form, fit, or function as described herein. The individual item requirements for device class M shall be in accordance with MIL-PRF-38535, appendix A for non-JAN class level B devices and as specified herein.

3.2 Design, construction, and physical dimensions. The design, construction, and physical dimensions shall be as specified in MIL-PRF-38535 and herein for device classes Q and V or MIL-PRF-38535, appendix A and herein for device class M.

3.2.1 Case outline(s). The case outline(s) shall be in accordance with 1.2.4 herein and figure 1.

3.2.2 Terminal connections. The terminal connections shall be as specified on figure 2.

3.2.3 Truth tables. The truth tables shall be as specified on figure 3.

3.3 Electrical performance characteristics and postirradiation parameter limits. Unless otherwise specified herein, the electrical performance characteristics and postirradiation parameter limits are as specified in table I and shall apply over the full case operating temperature range.

3.4 Electrical test requirements. The electrical test requirements shall be the subgroups specified in table II. The electrical tests for each subgroup are defined in table I.

3.5 Marking. The part shall be marked with the PIN listed in 1.2 herein. In addition, the manufacturer's PIN may also be marked. For packages where marking of the entire SMD PIN number is not feasible due to space limitations, the manufacturer has the option of not marking the "5962-" on the device. For RHA product using this option, the RHA designator shall still be marked. Marking for device classes Q and V shall be in accordance with MIL-PRF-38535. Marking for device class M shall be in accordance with MIL-PRF-38535, appendix A.

3.5.1 Certification/compliance mark. The certification mark for device classes Q and V shall be a "QML" or "Q" as required in MIL-PRF-38535. The compliance mark for device class M shall be a "C" as required in MIL-PRF-38535, appendix A.

3.6 Certificate of compliance. For device classes Q and V, a certificate of compliance shall be required from a QML-38535 listed manufacturer in order to supply to the requirements of this drawing (see 6.6.1 herein). For device class M, a certificate of compliance shall be required from a manufacturer in order to be listed as an approved source of supply in MIL-HDBK-103 (see 6.6.2 herein). The certificate of compliance submitted to DSCC-VA prior to listing as an approved source of supply for this drawing shall affirm that the manufacturer's product meets, for device classes Q and V, the requirements of MIL-PRF-38535 and herein or for device class M, the requirements of MIL-PRF-38535, appendix A and herein.

3.7 Certificate of conformance. A certificate of conformance as required for device classes Q and V in MIL-PRF-38535 or for device class M in MIL-PRF-38535, appendix A shall be provided with each lot of microcircuits delivered to this drawing.

3.8 Notification of change for device class M. For device class M, notification to DSCC-VA of change of product (see 6.2 herein) involving devices acquired to this drawing is required for any change that affects this drawing.

3.9 Verification and review for device class M. For device class M, DSCC, DSCC's agent, and the acquiring activity retain the option to review the manufacturer's facility and applicable required documentation. Offshore documentation shall be made available onshore at the option of the reviewer.

3.10 Microcircuit group assignment for device class M. Device class M devices covered by this drawing shall be in microcircuit group number 29 (see MIL-PRF-38535, appendix A).

STANDARD MICROCIRCUIT DRAWING DEFENSE SUPPLY CENTER COLUMBUS COLUMBUS, OHIO 43218-3990	SIZE A		5962-91528
		REVISION LEVEL B	SHEET 4

TABLE I. Electrical performance characteristics.

Test	Symbol	Conditions -55°C ≤ T _C ≤ +125°C unless otherwise specified	Group A subgroups	Device type	Limits		Unit
					Min	Max	
High level output voltage	V _{OH}	V _{IH} = -0.870 V, V _{EE} = -4.2 V, V _{IL} = -1.830 V	1, 2	All	-1.025	-0.870	V
			3		-1.085	-0.870	
Low level output voltage	V _{OL}	V _{IH} = -0.870 V, V _{EE} = -4.2 V, V _{IL} = -1.830 V	1, 2	All	-1.830	-1.620	V
			3		-1.830	-1.555	
High level threshold output voltage	V _{OHC}	V _{IH} = -1.165 V, V _{EE} = -4.2 V, V _{IL} = -1.475 V	1, 2	All	-1.035		V
			3		-1.085		
Low level threshold output voltage	V _{OLC}	V _{IH} = -1.165 V, V _{EE} = -4.2 V, V _{IL} = -1.475 V	1	01		-1.610	V
			2, 3			-1.555	
			1, 2	02		-1.610	
			3			-1.555	
High level input current	I _{IH}	V _{EE} = -5.7 V, V _{IN} = -0.870 V	1, 2	All		240	μA
			3			340	
Low level input current	I _{IL}	V _{EE} = -4.2 V, V _{IN} = -1.830 V	1, 2, 3	All	0.5		μA
Power supply drain current	I _{EE}	Inputs open, V _{EE} = -5.7 V, -4.2 V	1, 2, 3	01	-32	-12	mA
			1, 2, 3	02	-48	-17	mA
Truth table tests		V _{IH} = -1.018 V, V _{IL} = -1.652 V, See 4.4.1b	7, 8	All			
Propagation delay time, data to output	t _{PLH1} , t _{PHL1}	See figure 4	9	01	0.3	1.5	ns
			10		0.3	1.8	
			11		0.25	1.7	
	9		02	0.4	1.5	ns	
	10			0.4	1.7		
	11			0.3	1.8		
Propagation delay time, enable to output	t _{PLH2} , t _{PHL2}	9	02	0.8	2.3	ns	
		10		0.8	2.8		
		11		0.6	2.6		
Transition time, output	t _{TLH} , t _{THL}	See figure 4 <u>2/</u>	9	All	0.3	1.2	ns
			10		0.3	1.2	
			11		0.3	1.2	

1/ Each input/output, as applicable, shall be tested at the specified temperature for the specified limits. Output terminals shall be terminated through 50 Ω to -2 V. Input terminals not designated shall be high logic level, low logic level, or open.

2/ This parameter is provided as design information only (not tested but guaranteed).

STANDARD MICROCIRCUIT DRAWING DEFENSE SUPPLY CENTER COLUMBUS COLUMBUS, OHIO 43218-3990	SIZE A		5962-91528
		REVISION LEVEL B	SHEET 5

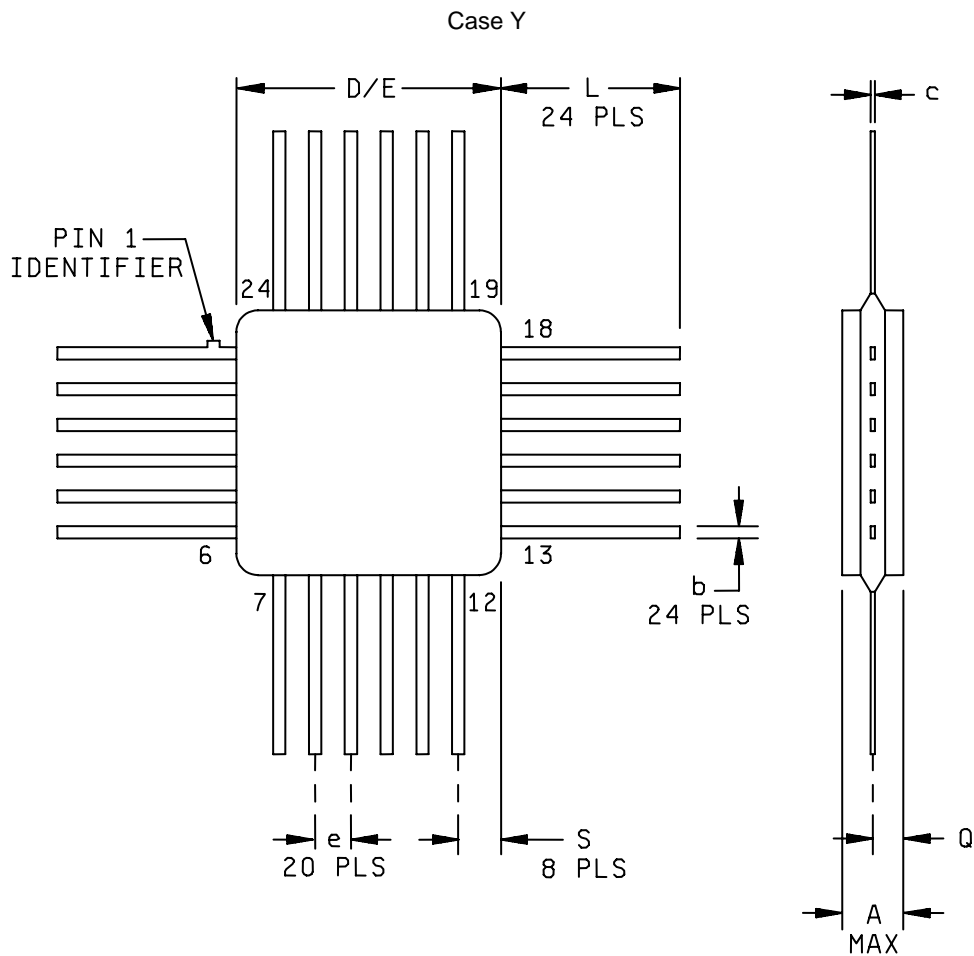

Symbol	Inches ^{1/}		Millimeters ^{1/}	
	Min	Max	Min	Max
A		.085		2.16
b	.016	.018	0.41	0.46
c	.004	.006	0.10	0.15
D/E	.370	.400 ^{2/}	9.40	10.16 ^{2/}
e	.045	.055	1.14	1.40
L	.250	.360	6.35	9.14
Q	.035	.050	0.89	1.27
S		.075		1.91
N	24		24	

NOTE:

1. The U.S. government preferred system of measurement is the metric SI system. However, since this item was originally designed using inch-pound units of measurement, in the event of conflict between the metric and inch-pound units, the inch-pound units shall take precedence.
2. This dimension allows for meniscus and glass overrun.

FIGURE 1. Case outline.

STANDARD MICROCIRCUIT DRAWING DEFENSE SUPPLY CENTER COLUMBUS COLUMBUS, OHIO 43218-3990	SIZE A		5962-91528
		REVISION LEVEL B	SHEET 6

Device types	01		02	
Case outlines	X	Y	X	Y
Terminal number	Terminal symbol			
1	D3c	D5b	D2e	D1d
2	D4c	D1c	Oe	D2d
3	D5c	D2c	$\bar{O}e$	D1e
4	Oc	D3c	$\bar{O}d$	D2e
5	$\bar{O}c$	D4c	Od	Oe
6	V _{CC}	D5c	V _{CC}	$\bar{O}e$
7	V _{CCA}	Oc	V _{CCA}	$\bar{O}d$
8	Ob	$\bar{O}c$	$\bar{O}c$	Od
9	$\bar{O}b$	V _{CC}	Oc	V _{CC}
10	$\bar{O}a$	V _{CCA}	Ob	V _{CCA}
11	Oa	O _b	$\bar{O}b$	$\bar{O}c$
12	D1a	$\bar{O}b$	$\bar{O}a$	Oc
13	D2a	$\bar{O}a$	Oa	Ob
14	D3a	Oa	D1a	$\bar{O}b$
15	D4a	D1a	D2a	$\bar{O}a$
16	D5a	D2a	D1b	Oa
17	D1b	D3a	D2b	D1a
18	V _{EE}	D4a	V _{EE}	D2a
19	D2b	D5a	E	D1b
20	D3b	D1b	D1c	D2b
21	D4b	V _{EE}	D2c	V _{EE}
22	D5b	D2b	D1d	E
23	D1c	D3b	D2d	D1c
24	D2c	D4b	D1e	D2c

FIGURE 2. Terminal connections.

STANDARD MICROCIRCUIT DRAWING DEFENSE SUPPLY CENTER COLUMBUS COLUMBUS, OHIO 43218-3990	SIZE A		5962-91528
		REVISION LEVEL B	SHEET 7

Device type 01

Inputs					Outputs	
D1	D2	D3	D4	D5	O	\bar{O}
L	L	L	L	L	L	H
H	X	X	X	X	H	L
X	H	X	X	X	H	L
X	X	H	X	X	H	L
X	X	X	H	X	H	L
X	X	X	X	H	H	L

H = High level
 L = Low level
 X = Irrelevant

Device type 02

Inputs			Outputs	
D1	D2	E	O	\bar{O}
L	L	L	L	H
L	H	L	H	L
H	L	L	H	L
H	H	L	H	L
X	X	H	H	L

H = High level
 L = Low level
 X = Irrelevant

FIGURE 3. Truth tables.

STANDARD MICROCIRCUIT DRAWING DEFENSE SUPPLY CENTER COLUMBUS COLUMBUS, OHIO 43218-3990	SIZE A		5962-91528
		REVISION LEVEL B	SHEET 8

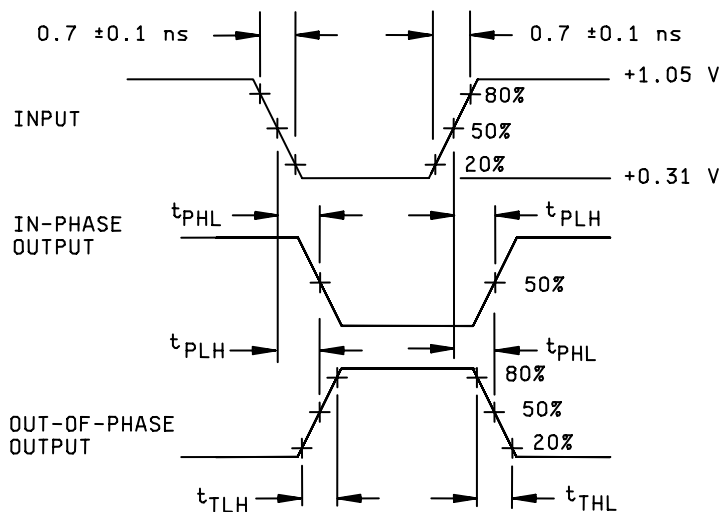
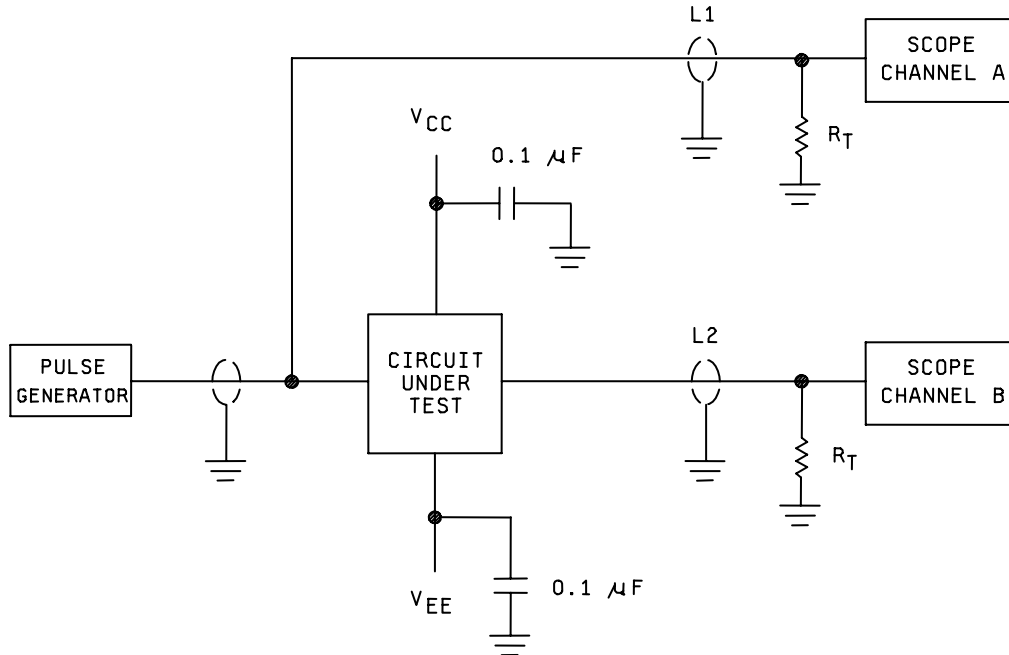

NOTES:

1. $V_{CC} = +2\text{ V}$, $V_{EE} = -2.5\text{ V}$.
2. L1 and L2 = equal length 50 Ω impedance lines.
3. $R_T = 50\ \Omega$ terminator internal to scope.
4. Decoupling 0.1 μF from GND to V_{CC} and V_{EE} .
5. All unused outputs are loaded with 50 Ω to GND.
6. $C_L =$ fixture and stray capacitance $\leq 3\text{ pF}$.

FIGURE 4. Test circuit and timing waveforms.

STANDARD MICROCIRCUIT DRAWING DEFENSE SUPPLY CENTER COLUMBUS COLUMBUS, OHIO 43218-3990	SIZE A		5962-91528
		REVISION LEVEL B	SHEET 9

4. VERIFICATION

4.1 Sampling and inspection. For device classes Q and V, sampling and inspection procedures shall be in accordance with MIL-PRF-38535 or as modified in the device manufacturer's Quality Management (QM) plan. The modification in the QM plan shall not affect the form, fit, or function as described herein. For device class M, sampling and inspection procedures shall be in accordance with MIL-PRF-38535, appendix A.

4.2 Screening. For device classes Q and V, screening shall be in accordance with MIL-PRF-38535, and shall be conducted on all devices prior to qualification and technology conformance inspection. For device class M, screening shall be in accordance with method 5004 of MIL-STD-883, and shall be conducted on all devices prior to quality conformance inspection.

4.2.1 Additional criteria for device class M.

- a. Burn-in test, method 1015 of MIL-STD-883.
 - (1) Test condition C or D. The test circuit shall be maintained by the manufacturer under document revision level control and shall be made available to the preparing or acquiring activity upon request. The test circuit shall specify the inputs, outputs, biases, and power dissipation, as applicable, in accordance with the intent specified in method 1015.
 - (2) $T_A = +125^{\circ}\text{C}$, minimum.
- b. Interim and final electrical test parameters shall be as specified in table II herein.

4.2.2 Additional criteria for device classes Q and V.

- a. The burn-in test duration, test condition and test temperature, or approved alternatives shall be as specified in the device manufacturer's QM plan in accordance with MIL-PRF-38535. The burn-in test circuit shall be maintained under document revision level control of the device manufacturer's Technology Review Board (TRB) in accordance with MIL-PRF-38535 and shall be made available to the acquiring or preparing activity upon request. The test circuit shall specify the inputs, outputs, biases, and power dissipation, as applicable, in accordance with the intent specified in method 1015 of MIL-STD-883.
- b. Interim and final electrical test parameters shall be as specified in table II herein.
- c. Additional screening for device class V beyond the requirements of device class Q shall be as specified in MIL-PRF-38535, appendix B.

4.3 Qualification inspection for device classes Q and V. Qualification inspection for device classes Q and V shall be in accordance with MIL-PRF-38535. Inspections to be performed shall be those specified in MIL-PRF-38535 and herein for groups A, B, C, D, and E inspections (see 4.4.1 through 4.4.4).

4.4 Conformance inspection. Technology conformance inspection for classes Q and V shall be in accordance with MIL-PRF-38535 including groups A, B, C, D, and E inspections and as specified herein. Quality conformance inspection for device class M shall be in accordance with MIL-PRF-38535, appendix A and as specified herein. Inspections to be performed for device class M shall be those specified in method 5005 of MIL-STD-883 and herein for groups A, B, C, D, and E inspections (see 4.4.1 through 4.4.4).

4.4.1 Group A inspection.

- a. Tests shall be as specified in table II herein.
- b. For device class M, subgroups 7 and 8 tests shall be sufficient to verify the truth table. For device classes Q and V, subgroups 7 and 8 shall include verifying the functionality of the device.
- c. Subgroups 4, 5, and 6 in table I, method 5005 of MIL-STD-883 shall be omitted.

STANDARD MICROCIRCUIT DRAWING DEFENSE SUPPLY CENTER COLUMBUS COLUMBUS, OHIO 43218-3990	SIZE A		5962-91528
		REVISION LEVEL B	SHEET 10

TABLE II. Electrical test requirements.

Test requirements	Subgroups (in accordance with MIL-STD-883, method 5005, table I)	Subgroups (in accordance with MIL-PRF-38535, table III)	
	Device class M	Device class Q	Device class V
Interim electrical parameters (see 4.2)	1	1	1
Final electrical parameters (see 4.2)	1, 2, 3, 7, 8, 9 <u>1/</u>	1, 2, 3, 7, 8, 9 10, 11 <u>1/</u>	1, 2, 3, 7, 8, 9 10, 11 <u>2/</u>
Group A test requirements (see 4.4)	1, 2, 3, 7, 8, 9 10, 11	1, 2, 3, 7, 8, 9 10, 11	1, 2, 3, 7, 8, 9 10, 11
Group C end-point electrical parameters (see 4.4)	1, 2, 3, 7, 8	1, 2, 3, 7, 8	1, 2, 3, 7, 8
Group D end-point electrical parameters (see 4.4)	1, 2, 3, 7, 8	1, 2, 3, 7, 8	1, 2, 3, 7, 8
Group E end-point electrical parameters (see 4.4)	1, 7, 9	1, 7, 9	1, 7, 9

1/ PDA applies to subgroup 1.

2/ PDA applies to subgroups 1 and 7.

4.4.2 Group C inspection. The group C inspection end-point electrical parameters shall be as specified in table II herein.

4.4.2.1 Additional criteria for device class M. Steady-state life test conditions, method 1005 of MIL-STD-883:

- a. Test condition C or D. The test circuit shall be maintained by the manufacturer under document revision level control and shall be made available to the preparing or acquiring activity upon request. The test circuit shall specify the inputs, outputs, biases, and power dissipation, as applicable, in accordance with the intent specified in method 1005 of MIL-STD-883.
- b. $T_A = +125^\circ\text{C}$, minimum.
- c. Test duration: 1,000 hours, except as permitted by method 1005 of MIL-STD-883.

4.4.2.2 Additional criteria for device classes Q and V. The steady-state life test duration, test condition and test temperature, or approved alternatives shall be as specified in the device manufacturer's QM plan in accordance with MIL-PRF-38535. The test circuit shall be maintained under document revision level control by the device manufacturer's TRB in accordance with MIL-PRF-38535 and shall be made available to the acquiring or preparing activity upon request. The test circuit shall specify the inputs, outputs, biases, and power dissipation, as applicable, in accordance with the intent specified in method 1005 of MIL-STD-883.

STANDARD MICROCIRCUIT DRAWING DEFENSE SUPPLY CENTER COLUMBUS COLUMBUS, OHIO 43218-3990	SIZE A		5962-91528
		REVISION LEVEL B	SHEET 11

4.4.3 Group D inspection. The group D inspection end-point electrical parameters shall be as specified in table II herein.

4.4.4 Group E inspection. Group E inspection is required only for parts intended to be marked as radiation hardness assured (see 3.5 herein).

- a. End-point electrical parameters shall be as specified in table II herein.
- b. For device classes Q and V, the devices or test vehicle shall be subjected to radiation hardness assured tests as specified in MIL-PRF-38535 for the RHA level being tested. For device class M, the devices shall be subjected to radiation hardness assured tests as specified in MIL-PRF-38535, appendix A for the RHA level being tested. All device classes must meet the postirradiation end-point electrical parameter limits as defined in table I at $T_A = +25^\circ\text{C} \pm 5^\circ\text{C}$, after exposure, to the subgroups specified in table II herein.

5. PACKAGING

5.1 Packaging requirements. The requirements for packaging shall be in accordance with MIL-PRF-38535 for device classes Q and V or MIL-PRF-38535, appendix A for device class M.

6. NOTES

6.1 Intended use. Microcircuits conforming to this drawing are intended for use for Government microcircuit applications (original equipment), design applications, and logistics purposes.

6.1.1 Replaceability. Microcircuits covered by this drawing will replace the same generic device covered by a contractor prepared specification or drawing.

6.1.2 Substitutability. Device class Q devices will replace device class M devices.

6.2 Configuration control of SMD's. All proposed changes to existing SMD's will be coordinated with the users of record for the individual documents. This coordination will be accomplished using DD Form 1692, Engineering Change Proposal.

6.3 Record of users. Military and industrial users should inform Defense Supply Center Columbus (DSCC) when a system application requires configuration control and which SMD's are applicable to that system. DSCC will maintain a record of users and this list will be used for coordination and distribution of changes to the drawings. Users of drawings covering microelectronic devices (FSC 5962) should contact DSCC-VA, telephone (614) 692-0544.

6.4 Comments. Comments on this drawing should be directed to DSCC-VA, Columbus, Ohio 43218-3990, or telephone (614) 692-0547.

6.5 Abbreviations, symbols, and definitions. The abbreviations, symbols, and definitions used herein are defined in MIL-PRF-38535 and MIL-HDBK-1331.

6.6 Sources of supply.

6.6.1 Sources of supply for device classes Q and V. Sources of supply for device classes Q and V are listed in QML-38535. The vendors listed in QML-38535 have submitted a certificate of compliance (see 3.6 herein) to DSCC-VA and have agreed to this drawing.

6.6.2 Approved sources of supply for device class M. Approved sources of supply for class M are listed in MIL-HDBK-103. The vendors listed in MIL-HDBK-103 have agreed to this drawing and a certificate of compliance (see 3.6 herein) has been submitted to and accepted by DSCC-VA.

STANDARD MICROCIRCUIT DRAWING DEFENSE SUPPLY CENTER COLUMBUS COLUMBUS, OHIO 43218-3990	SIZE A		5962-91528
		REVISION LEVEL B	SHEET 12

STANDARD MICROCIRCUIT DRAWING BULLETIN

DATE: 06-08-01

Approved sources of supply for SMD 5962-91528 are listed below for immediate acquisition information only and shall be added to MIL-HDBK-103 and QML-38535 during the next revision. MIL-HDBK-103 and QML-38535 will be revised to include the addition or deletion of sources. The vendors listed below have agreed to this drawing and a certificate of compliance has been submitted to and accepted by DSCC-VA. This information bulletin is superseded by the next dated revision of MIL-HDBK-103 and QML-38535.

Standard microcircuit drawing PIN <u>1/</u>	Vendor CAGE number	Vendor similar PIN <u>2/</u>
5962-9152801MXA	0C7V7	100301DMQB
5962-9152801MYA	0C7V7	100301FMQB
	27014	100301FMQB
5962-9152801VXA	<u>3/</u>	100301DMQB
5962-9152801VYA	27014	100301W-QMLV
5962-9152802MXA	0C7V7	100302DMQB
	27014	100302DMQB
5962-9152802MYA	0C7V7	100302FMQB
	27014	100302FMQB
5962-9152802VXA	27014	100302J-QMLV
5962-9152802VYA	27014	100302W-QMLV

1/ The lead finish shown for each PIN representing a hermetic package is the most readily available from the manufacturer listed for that part. If the desired lead finish is not listed contact the vendor to determine its availability.

2/ Caution. Do not use this number for item acquisition. Items acquired to this number may not satisfy the performance requirements of this drawing.

3/ Not available from an approved source of supply.

Vendor CAGE number

Vendor name and address

27014

National Semiconductor Corporation
2900 Semiconductor Drive
P. O. Box 58090
Santa Clara, CA 95052-8090

0C7V7

QP Semiconductor
2945 Oakmead Village Court
Santa Clara, CA 95051

The information contained herein is disseminated for convenience only and the Government assumes no liability whatsoever for any inaccuracies in the information bulletin.

X-ON Electronics

Largest Supplier of Electrical and Electronic Components

Click to view similar products for [Logic Gates](#) category:

Click to view products by [E2v](#) manufacturer:

Other Similar products are found below :

[5962-8769901BCA](#) [74HC85N](#) [NL17SG08P5T5G](#) [NL17SG32DFT2G](#) [NLU1G32AMUTCG](#) [NLV7SZ58DFT2G](#) [NLVHC1G08DFT1G](#)
[NLVVHC1G14DTT1G](#) [NLX2G08DMUTCG](#) [NLX2G08MUTCG](#) [MC74HCT20ADR2G](#) [091992B](#) [091993X](#) [093560G](#) [634701C](#) [634921A](#)
[NL17SG32P5T5G](#) [NL17SG86DFT2G](#) [NLU1G32CMUTCG](#) [NLV14001UBDR2G](#) [NLVVHC1G132DTT1G](#) [NLVVHC1G86DTT1G](#)
[NLX1G11AMUTCG](#) [NLX1G97MUTCG](#) [746427X](#) [74AUP1G17FW5-7](#) [74LS38](#) [74LVC1G08Z-7](#) [74LVC32ADTR2G](#) [74LVC1G125FW4-7](#)
[74LVC08ADTR2G](#) [MC74HCT20ADTR2G](#) [NLV14093BDTR2G](#) [NLV17SZ00DFT2G](#) [NLV17SZ02DFT2G](#) [NLV17SZ126DFT2G](#)
[NLV27WZ17DFT2G](#) [NLV74HC02ADR2G](#) [NLV74HC08ADR2G](#) [NLVVHC1GT32DFT1G](#) [74HC32S14-13](#) [74LS133](#) [74LVC1G32Z-7](#)
[M38510/30402BDA](#) [74LVC1G86Z-7](#) [74LVC2G08RA3-7](#) [M38510/06202BFA](#) [NLV74HC08ADTR2G](#) [NLV74HC14ADR2G](#)
[NLV74HC20ADR2G](#)