

61082-AA B C D E G V FF

AA	POSITION
02	2X10
04	2X20
06	2X30
08	2X40
10	2X50
12	2X60
14	2X70
16	2X80
18	2X90
20	2X100

NOTE 10

B	FOR PLUG, SEE DWG. NO. 61083			
COMBINATION OF MATED HEIGHT	Plug 1	Plug 2	Plug 3	Plug 4
Recep 1				
Recep 2				
Recep 3				
Recep 4				

V	MANDATORY CODE
/	STANDARD, NOT MANDATORY P/N
V	ONLY FOR DEDICATED CUSTOMER

G	DATE CODE
/	NOT PRINT DATE CODE
P	PRINT DATE CODE

E	PACKAGING
0	TUBE WITHOUT METAL CAP
2	T&R WITH METAL CAP
9	TUBE WITH METAL CAP
6	T&R WITHOUT METAL CAP (WITH KAPTON TAPE)
Q	T&R WITHOUT CAP

NOTE 10
NOTE 10

D	POLARIZATION PEG	HOLD DOWN
0	YES	NO
2	NO	NO

C	PLATING ON CONTACT AREA	FF
0	GOLD 0.2um MIN / TIN LEAD NICKEL UNDERPLATE OVERALL 1.27um MIN	NONE
1	GOLD FLASH (0.065um MIN) OVER PALLADIUM-NICKEL 0.69um MIN / TIN LEAD NICKEL UNDERPLATE OVERALL 1.27um MIN	NONE
4	GOLD 0.2um MIN / PURE TIN 2um MIN (LEAD FREE) NICKEL UNDERPLATE OVERALL 1.27um MIN	LF
5	GOLD 0.38um MIN / PURE TIN 2um MIN (LEAD FREE) NICKEL UNDERPLATE OVERALL 1.27um MIN	LF
6	GOLD FLASH (0.065um MIN) OVER PALLADIUM-NICKEL 0.69um MIN / PURE TIN 2um MIN (LEAD FREE) NICKEL UNDERPLATE OVERALL 1.27um MIN	LF
7	GOLD 0.76um MIN / PURE TIN 2um MIN (LEAD FREE) NICKEL UNDERPLATE OVERALL 1.27um MIN	LF

NOTE:

- MATERIAL:
HOUSING: G.F. LCP, NATURAL, UL94-V0
TERMINAL: NICKEL COPPER
- PLATING: AS SHOWN IN TABLE.
- SEE GS-12-547 FOR PRODUCT SPEC.
- PACKAGING OPTION 2: NOT ALL SIZES ARE AVAILABLE. CHECK WITH FACTORY.
- THIS PRODUCT MEETS THE EUROPEAN UNION DIRECTIVES AND OTHER COUNTRY REGULATIONS AS DESCRIBED IN GS-22-008.
- THE HOUSING WILL WITHSTAND EXPOSURE UP TO 260~ PEAK TEMPERATURE FOR 30 SECONDS IN A CONVECTION, INFRA-RED OR VAPOR PHASE REFLOW OVEN.
- PLATING OPTION "4" IS LEADFREE ALTERNATIVE FOR OPTION "0", AND OPTION "6" IS LEADFREE ALTERNATIVE FOR OPTION "1".
- HIGH PRECISION COPLANARITY IS AVAILABLE FOR 2X80 TO 2X100 POS, ALL HEIGHTS. PLS REFER TO PRINT 10069525.
- THE P/N 61082-***** OR 61082-*****LF NOT PRINT DATE CODE.
THE P/N 61082-*****P OR 61082-*****PLF NEED PRINT DATE CODE.
- 2X10 POSITION ONLY APPLY TO RECEPTACLE 4.
PACKAGING WITH METAL CAP DOES NOT APPLY TO 2X10 POSITION.

spec ref	dr	Matthew Cheong	2009/06/10	projection	MM	size	A3	scale	3:1
tolerance std	eng	Bob Gu	2017/04/14		← →	ecn no	ELX-N-26378-1	rel level	Released
ISO 406 ISO 1101	chr	-	-						
surface	linear	0.X	±0.20	product family	-	dwg no	61082	rev	AG
		0.XX	±0.15						
ISO 1302	angular	0°	±2°	www.fci.com	cat. no.	-	Product - Customer Drw	sheet 1 of 7	

Amphenol FCI

title BERGSTAK 0.8MM
RECEPTACLE ASS'Y

Amphenol FCI

© 2016 AFCI

PRODUCT NO.	NUMBER OF POSITIONS	DIMENSION		
		A	B	C
61082-041***	2X20	15.2	21.8	20.2
61082-061***	2X30	23.2	29.8	28.2
61082-081***	2X40	31.2	37.8	36.2
61082-101***	2X50	39.2	45.8	44.2
61082-121***	2X60	47.2	53.8	52.2
61082-141***	2X70	55.2	61.8	60.2
61082-161***	2X80	63.2	69.8	68.2
61082-181***	2X90	71.2	77.8	76.2
61082-201***	2X100	79.2	85.8	84.2

DATE CODE: XXXXXX
 DAY(01~31)
 MONTH(01~12)
 YEAR(00~99)

DETAIL F

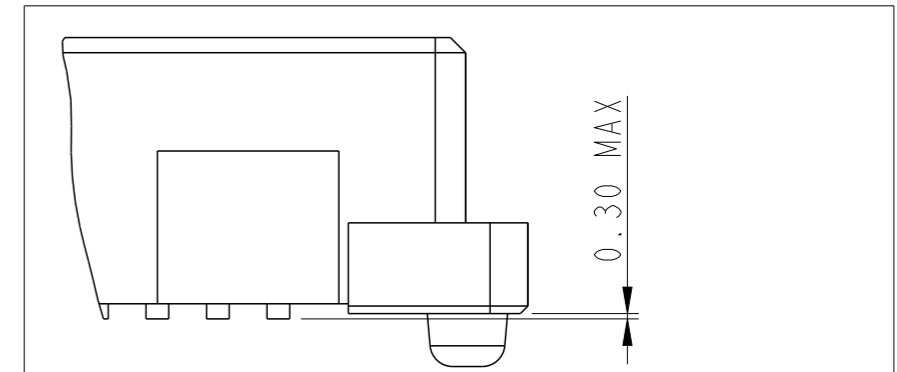

COPLANARITY OF TAIL:
 0.1 MAX. APPLIED TO 2X20 TO 2X70 POS.
 0.13 MAX APPLIED TO 2X80 TO 2X100 POS.

HIGH PRECISION COPLANARITY IS AVAILABLE FOR 2X80 TO 2X100 POS.
 PLS REFER TO PRINT 10069524.

DETAIL A
 SCALE 10:1

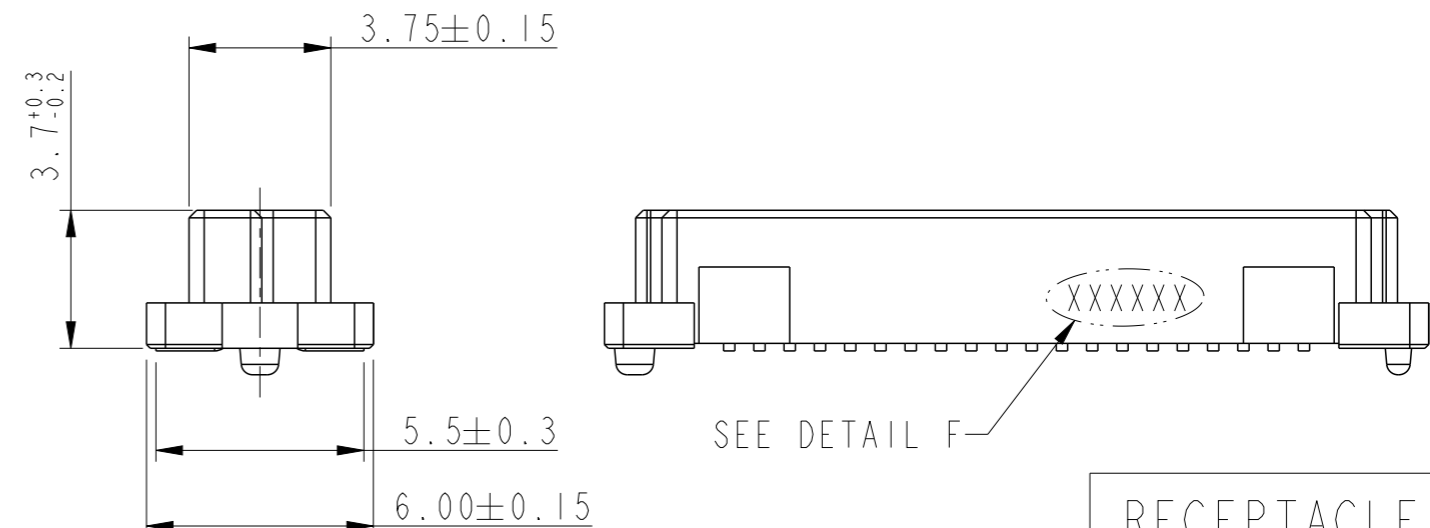
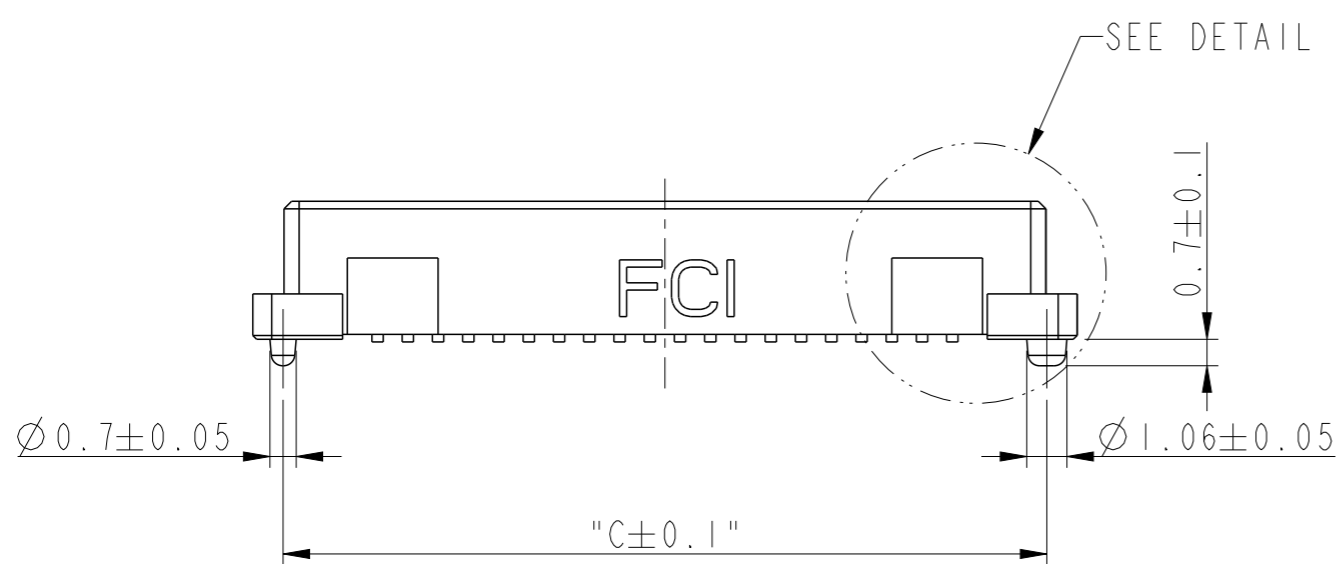
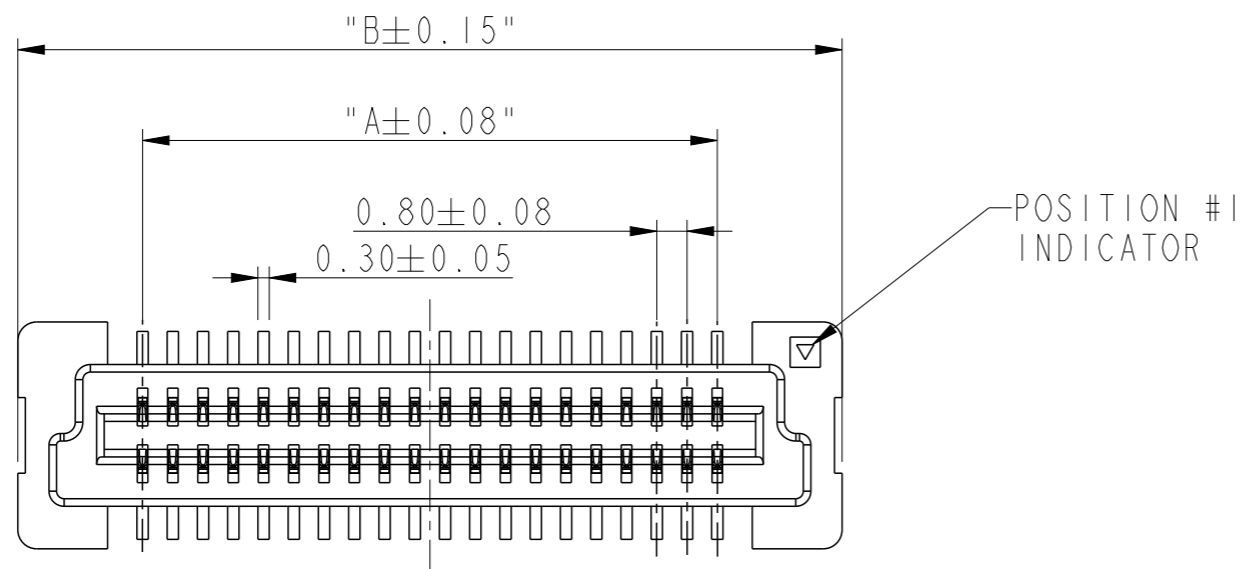

dr	Matthew Cheong	2009/06/10	projection	MM	size	A3	scale	3:1	
eng	Bob Gu	2017/04/14			ecn no	ELX-N-26378-1			
chr	-	-			rel level	Released			
appr	Tim Yao	2017/04/14	product family	-	rel level	Released			
Amphenol FCI		BERGSTAK 0.8MM RECEPTACLE ASS'Y			dwg no	61082		rev	AG
www.fci.com		cat. no.	-	Product - Customer Drw	sheet 2 of 7				

RECEPTACLE 1

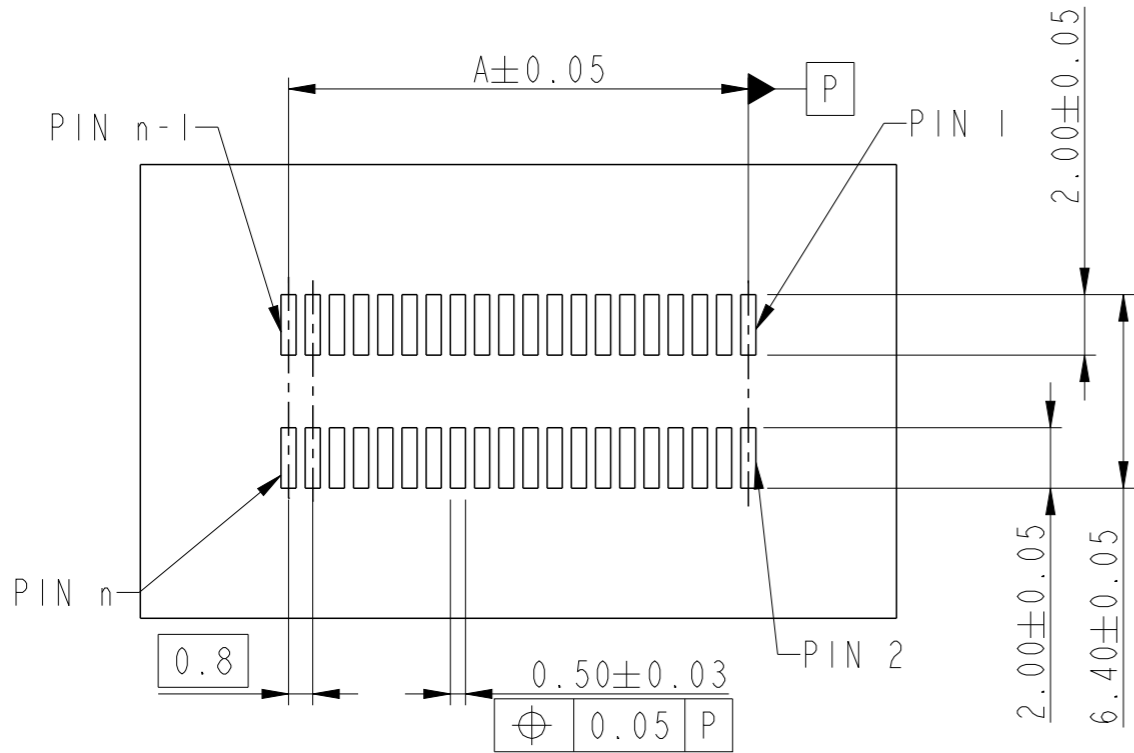

RECOMMENDED PCB LAYOUT WITHOUT PEGS AND HOLDDOWN

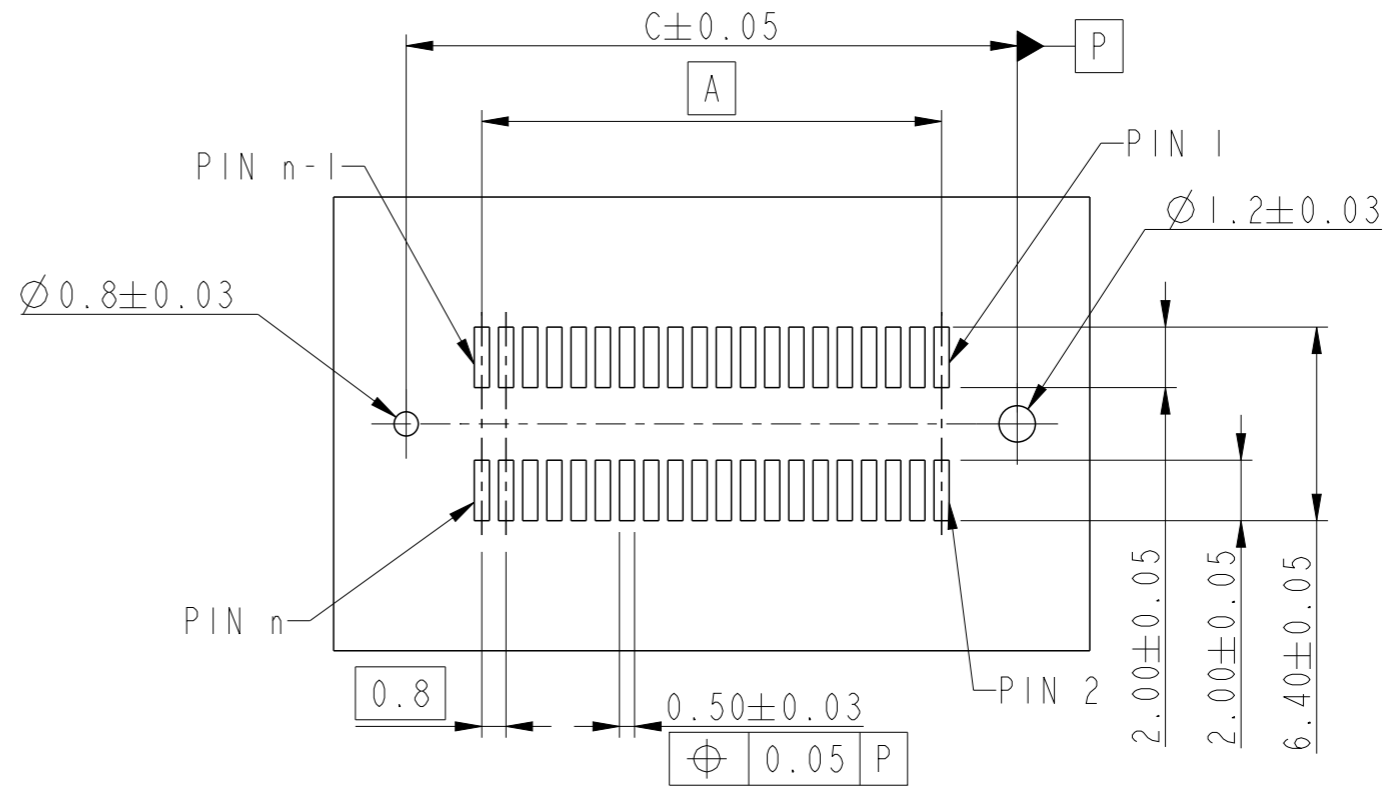

RECOMMENDED PCB LAYOUT WITH PEGS
FOR NO. OF POSITION 2X20, 2X30, 2X40, 2X50, 2X60

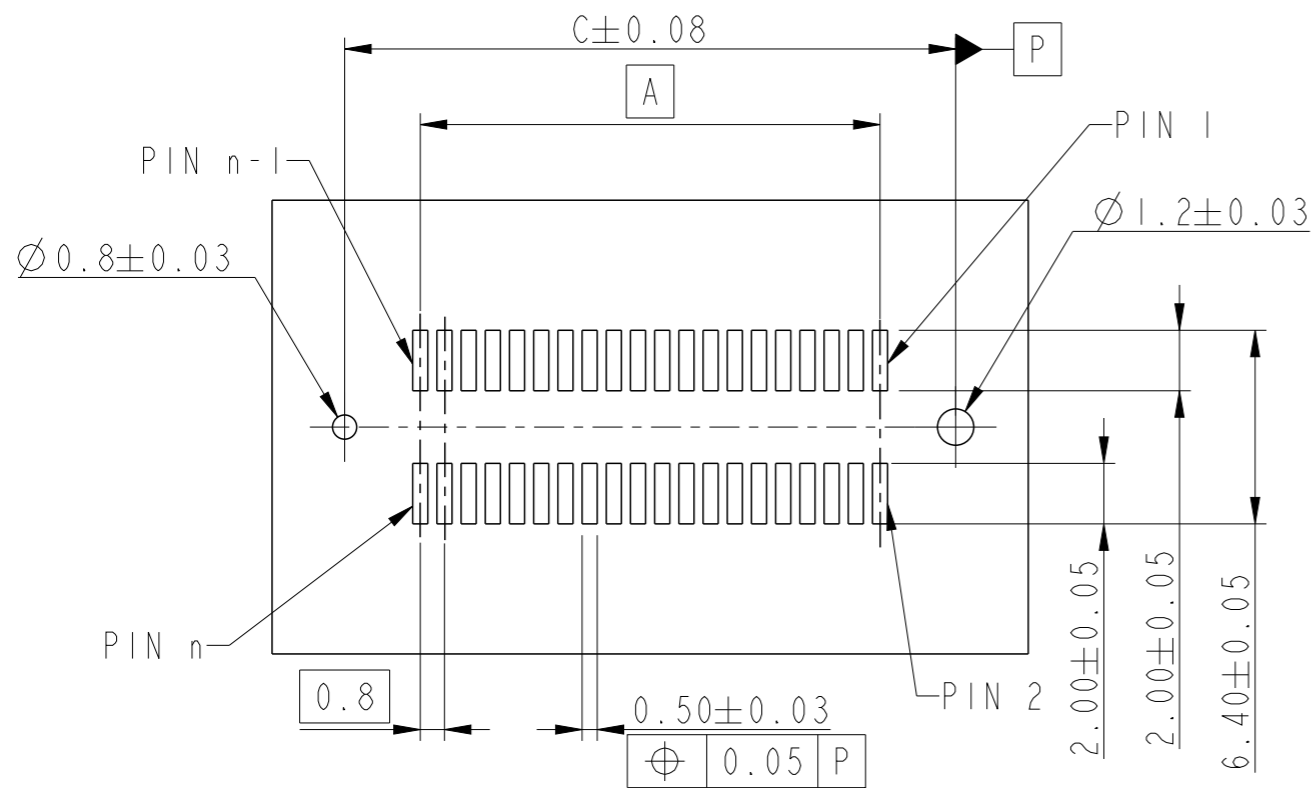

RECOMMENDED PCB LAYOUT WITH PEGS
FOR NO. OF POSITION 2X70, 2X80, 2X90, 2X100

dr	Matthew Cheong	2009/06/10	projection	MM	size	A3	scale	3:1
eng	Bob Gu	2017/04/14			ecn no	ELX-N-26378-1		
chr	-	-			rel level	Released		
appr	Tim Yao	2017/04/14	product family	-	rel level	Released		
Amphenol FCI		title BERGSTAK 0.8MM RECEPTACLE ASS'Y			dwg no 61082	rev AG		
www.fci.com		cat. no.	Product - Customer Drw		sheet 3 of 7			

PRODUCT NO.	NUMBER OF POSITIONS	DIMENSION		
		A	B	C
61082-042***	2X20	15.2	21.8	20.2
61082-062***	2X30	23.2	29.8	28.2
61082-082***	2X40	31.2	37.8	36.2
61082-102***	2X50	39.2	45.8	44.2
61082-122***	2X60	47.2	53.8	52.2
61082-142***	2X70	55.2	61.8	60.2
61082-162***	2X80	63.2	69.8	68.2
61082-182***	2X90	71.2	77.8	76.2
61082-202***	2X100	79.2	85.8	84.2

DATE CODE: XXXXXX

DAY(01~31)
MONTH(01~12)
YEAR(00~99)

DETAIL G

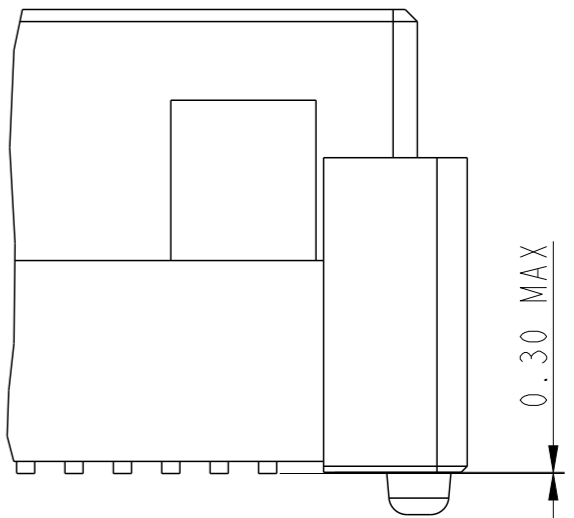

COPLANARITY OF TAIL
0.1 MAX APPLIED TO 2X20 TO 2X70 POS.
0.13 MAX APPLIED TO 2X80 TO 2X100 POS.

HIGH PRECISION COPLANARITY IS AVAILABLE FOR 2X80 TO 2X100 POS.
PLS REFER TO PRINT 10069524.

DETAIL C
SCALE 8:1

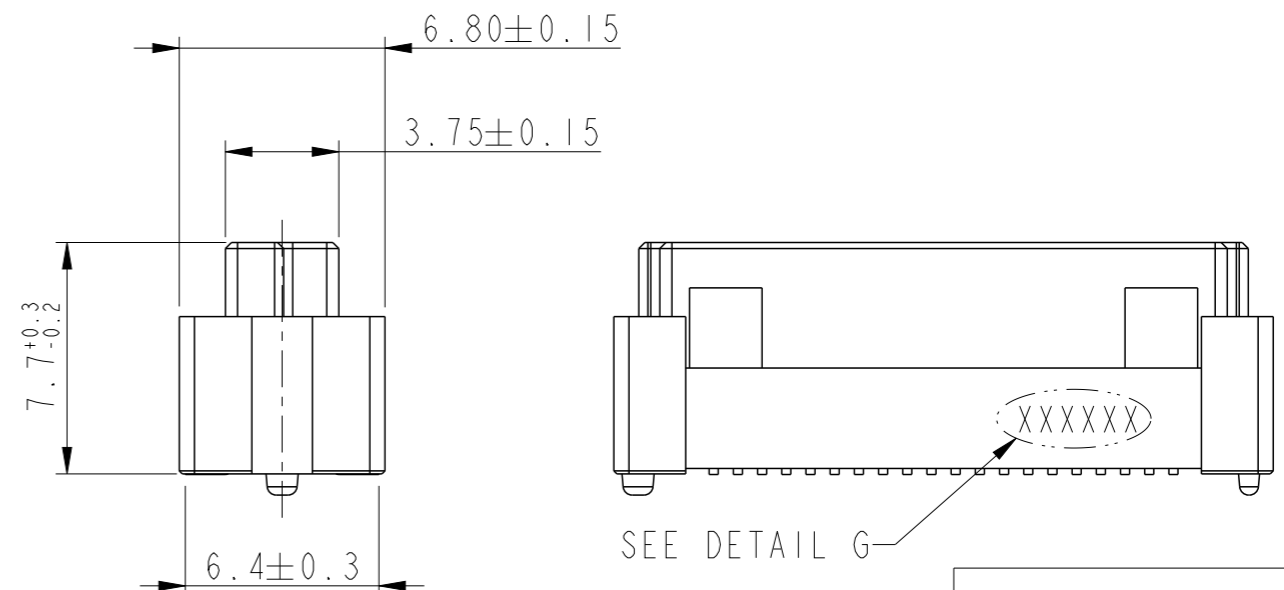
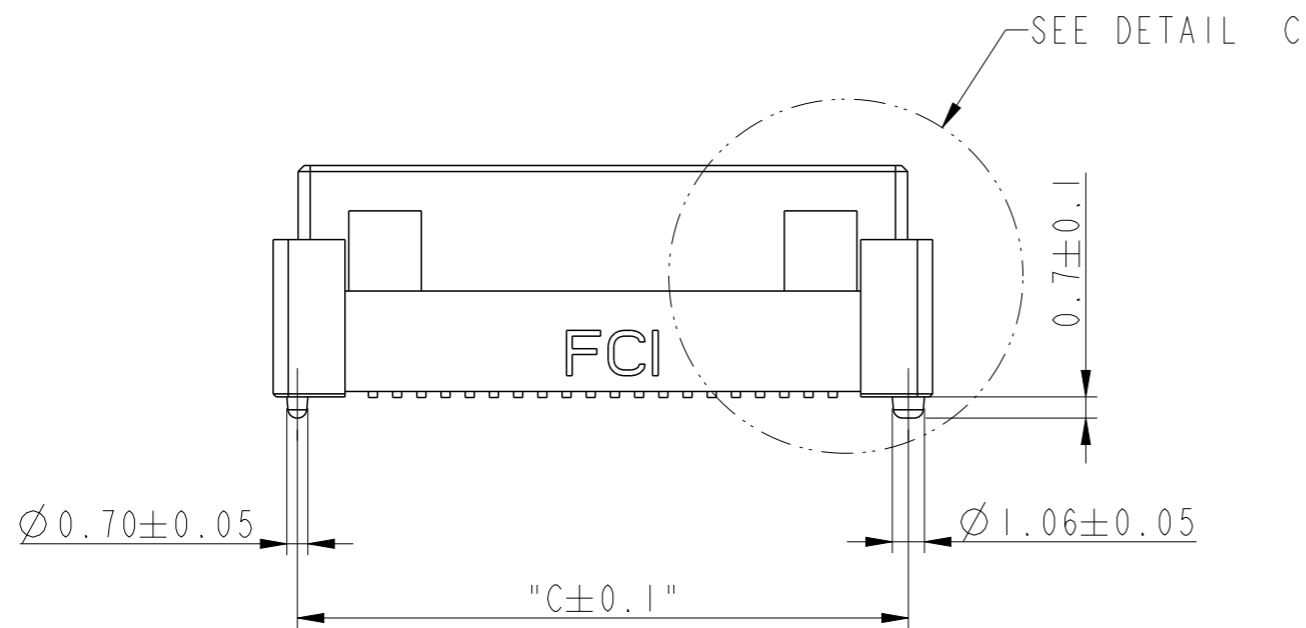
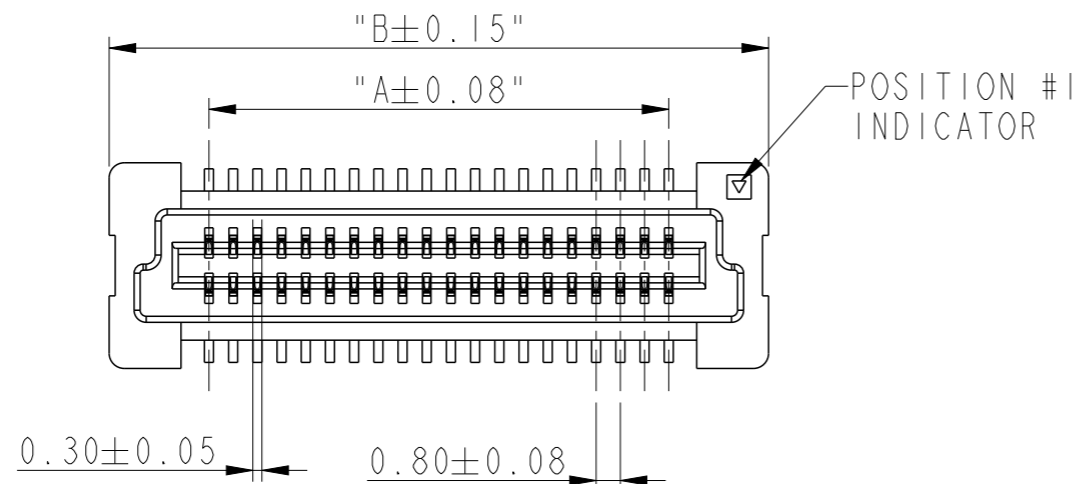

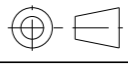
dr	Matthew Cheong	2009/06/10	projection	MM	size	A3	scale	3:1
eng	Bob Gu	2017/04/14		← →	ecn no	ELX-N-26378-1		
chr	-	-			product family	-	rel level	Released
appr	Tim Yao	2017/04/14	Amphenol FCI BERGSTAK 0.8MM RECEPTACLE ASS'Y			dwg no	61082	rev
www.fci.com			cat. no.			Product - Customer Drw		sheet 4 of 7

A

B

C

D

A

B

C

D



AG

PRODUCT NO.	NUMBER OF POSITIONS	DIMENSION		
		A	B	C
61082-043***	2X20	15.2	21.8	20.2
61082-063***	2X30	23.2	29.8	28.2
61082-083***	2X40	31.2	37.8	36.2
61082-103***	2X50	39.2	45.8	44.2
61082-123***	2X60	47.2	53.8	52.2
61082-143***	2X70	55.2	61.8	60.2
61082-163***	2X80	63.2	69.8	68.2
61082-183***	2X90	71.2	77.8	76.2
61082-203***	2X100	79.2	85.8	84.2

DATE CODE: XXXXXX

DAY(01~31)
MONTH(01~12)
YEAR(00~99)

DETAIL H

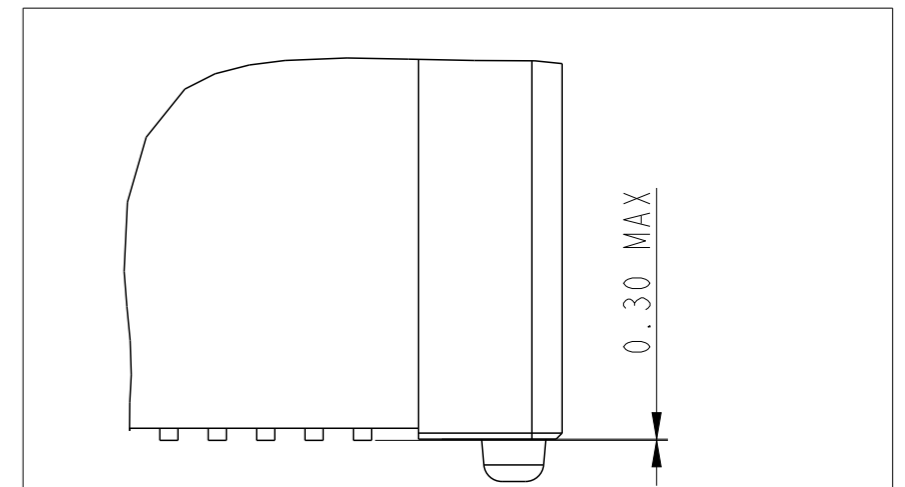

COPLANARITY OF TAIL
0.1 MAX APPLIED TO 2X20 TO 2X70 POS
0.13 MAX APPLIED TO 2X80 TO 2X100 POS.

HIGH PRECISION COPLANARITY IS AVAILABLE FOR 2X80 TO 2X100 POS.
PLS REFER TO PRINT 10069524.

DETAIL E
SCALE 8:1

A

A

B

B

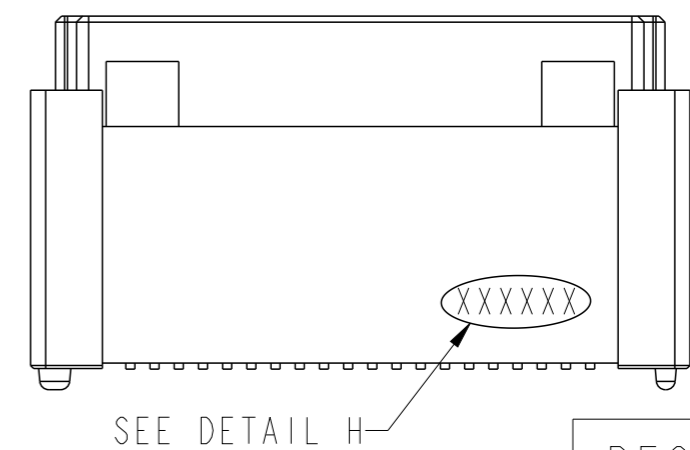
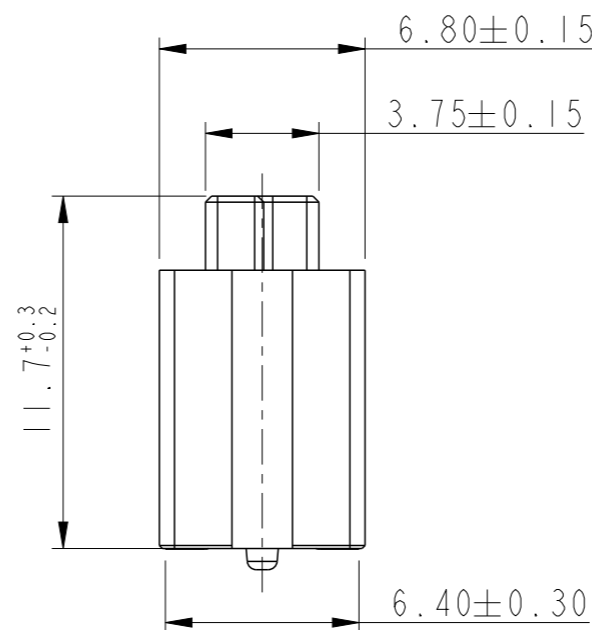
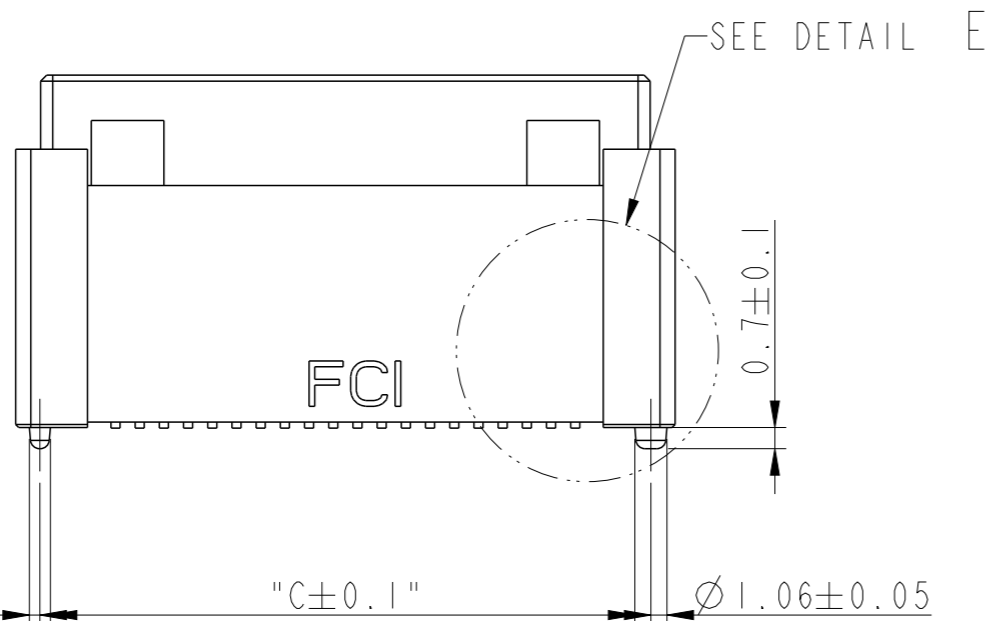
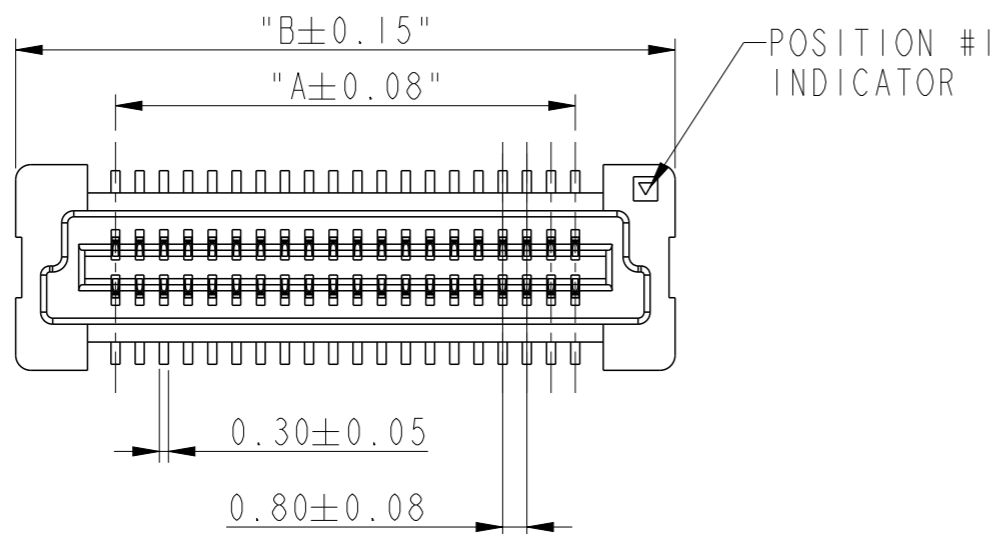

RECEPTACLE 3

dr	Matthew Cheong	2009/06/10	projection	MM	size	A3	scale	3:1		
eng	Bob Gu	2017/04/14			ecn no	ELX-N-26378-1				
chr	-	-			product family	-	rel level	Released		
appr	Tim Yao	2017/04/14	Amphenol FCI			BERGSTAK 0.8MM	dwg no	61082	rev	AG
www.fci.com			cat. no.			-		Product - Customer Drw	sheet 5 of 7	

PRODUCT NO.	NUMBER OF POSITIONS	DIMENSION		
		A	B	C
61082-024***	2X10	7.2	13.8	12.2
61082-044***	2X20	15.2	21.8	20.2
61082-064***	2X30	23.2	29.8	28.2
61082-084***	2X40	31.2	37.8	36.2
61082-104***	2X50	39.2	45.8	44.2
61082-124***	2X60	47.2	53.8	52.2
61082-144***	2X70	55.2	61.8	60.2
61082-164***	2X80	63.2	69.8	68.2
61082-184***	2X90	71.2	77.8	76.2
61082-204***	2X100	79.2	85.8	84.2

DATE CODE: XXXXXX

DAY(01~31)
MONTH(01~12)
YEAR(00~99)

DETAIL K

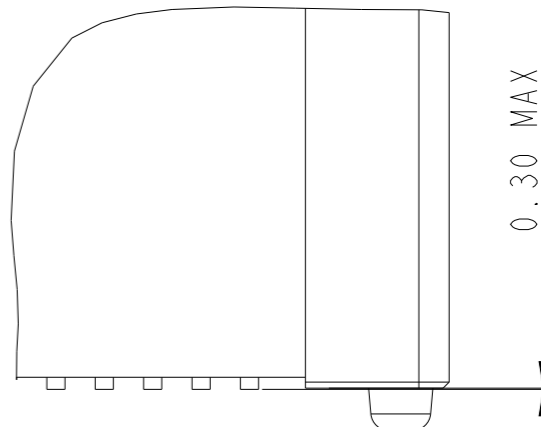



COPLANARITY OF TAIL
0.1 MAX APPLIED TO 2X20 TO 2X70 POS
0.13 MAX APPLIED TO 2X80 TO 2X100 POS.

HIGH PRECISION COPLANARITY IS AVAILABLE FOR 2X80 TO 2X100 POS.
PLS REFER TO PRINT 10069524.

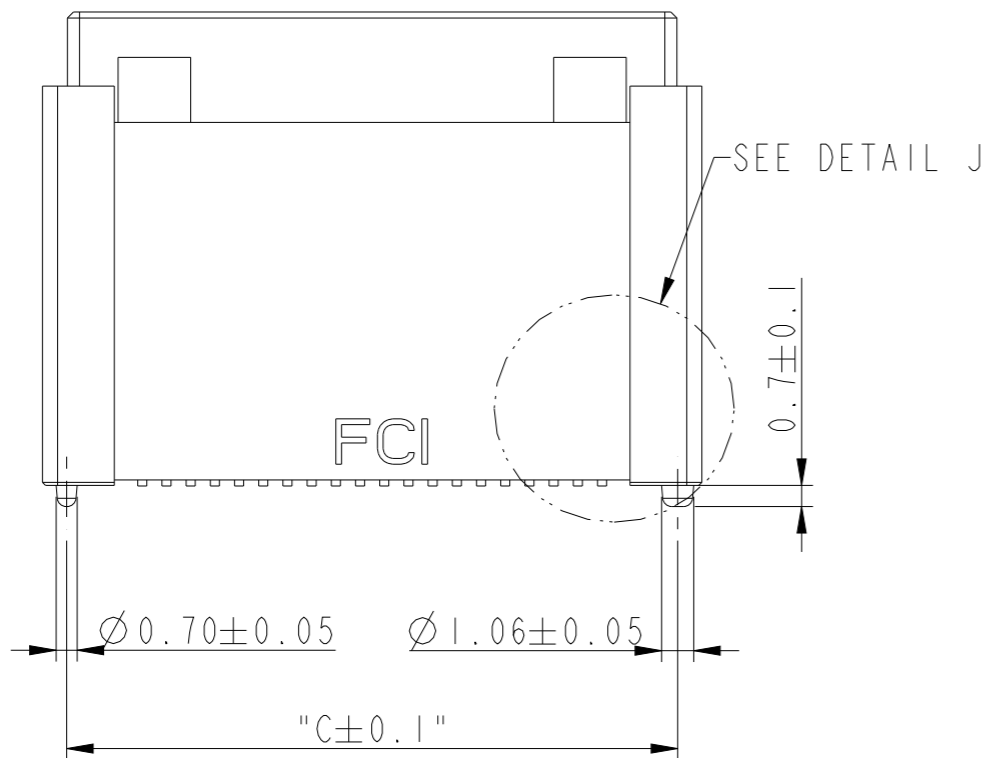
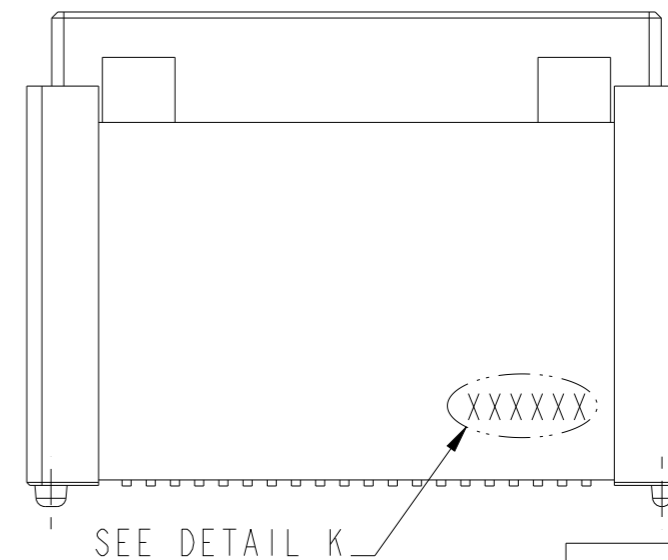
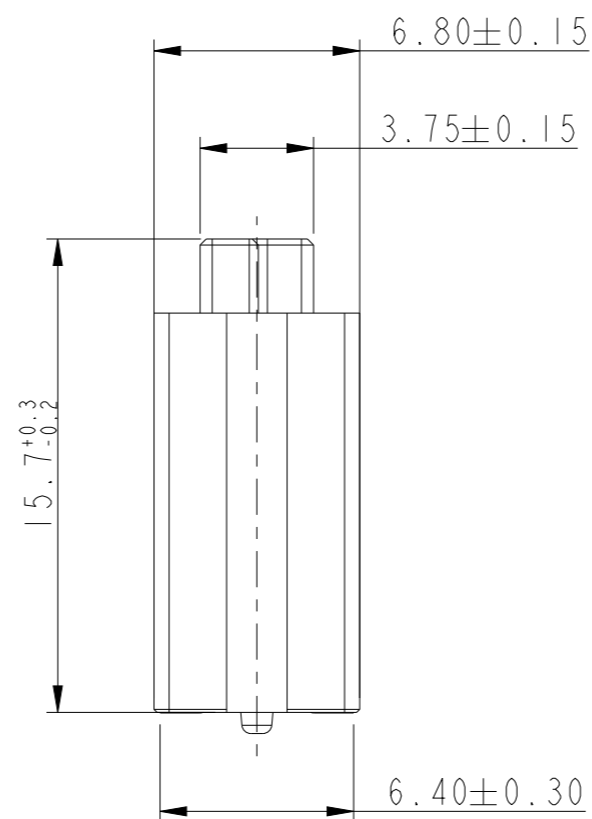
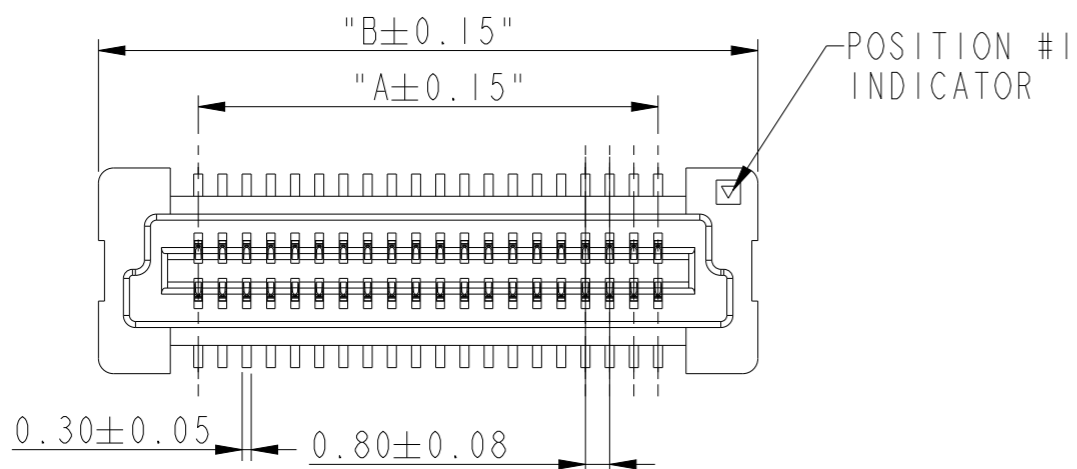
DETAIL J
SCALE 8:1

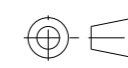

dr	Matthew Cheong	2009/06/10	projection	MM	size	A3	scale	3:1
eng	Bob Gu	2017/04/14			ecn no ELX-N-26378-1			
chr	-	-			rel level Released			
appr	Tim Yao	2017/04/14	product family		-			
Amphenol FCI		BERGSTAK 0.8MM			dwg no		61082	
www.fci.com		RECEPTACLE ASS'Y			rev		AG	
cat. no.		-		Product - Customer Drw		sheet 6 of 7		

RECEPTACLE 2 & 3 & 4

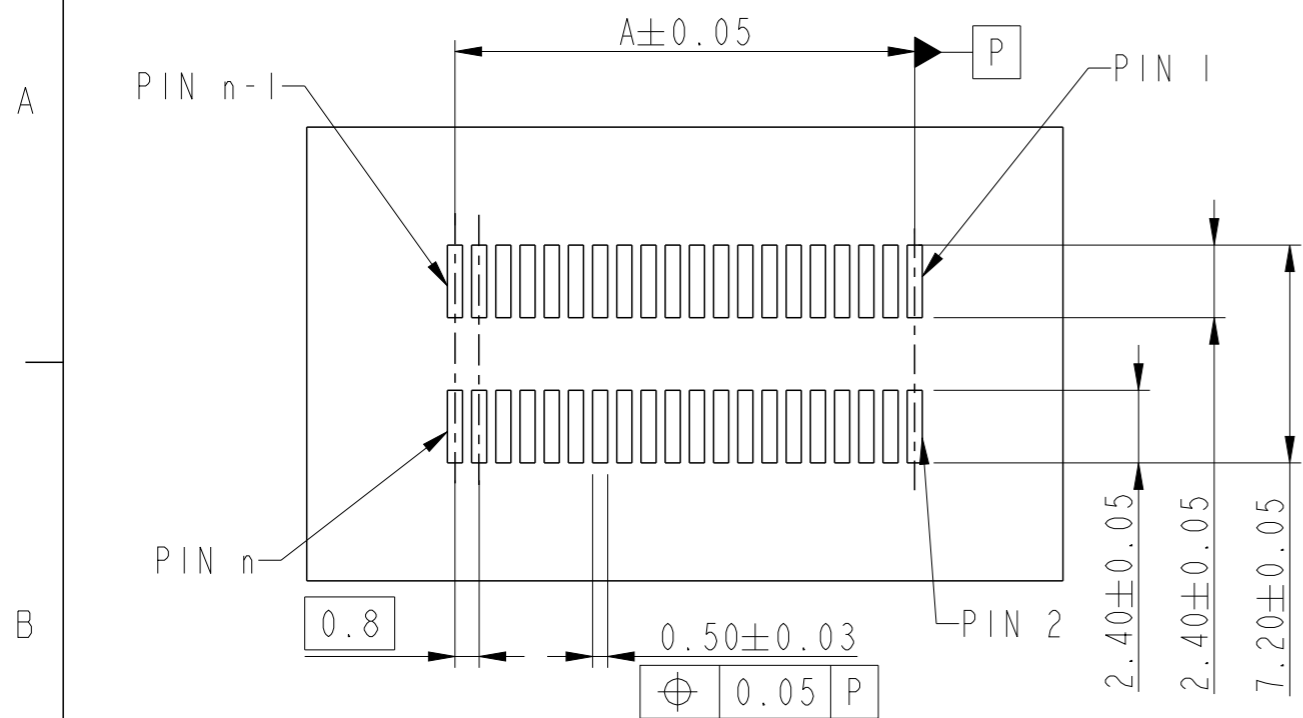

RECOMMENDED PCB LAYOUT WITHOUT PEGS AND HOLDDOWN

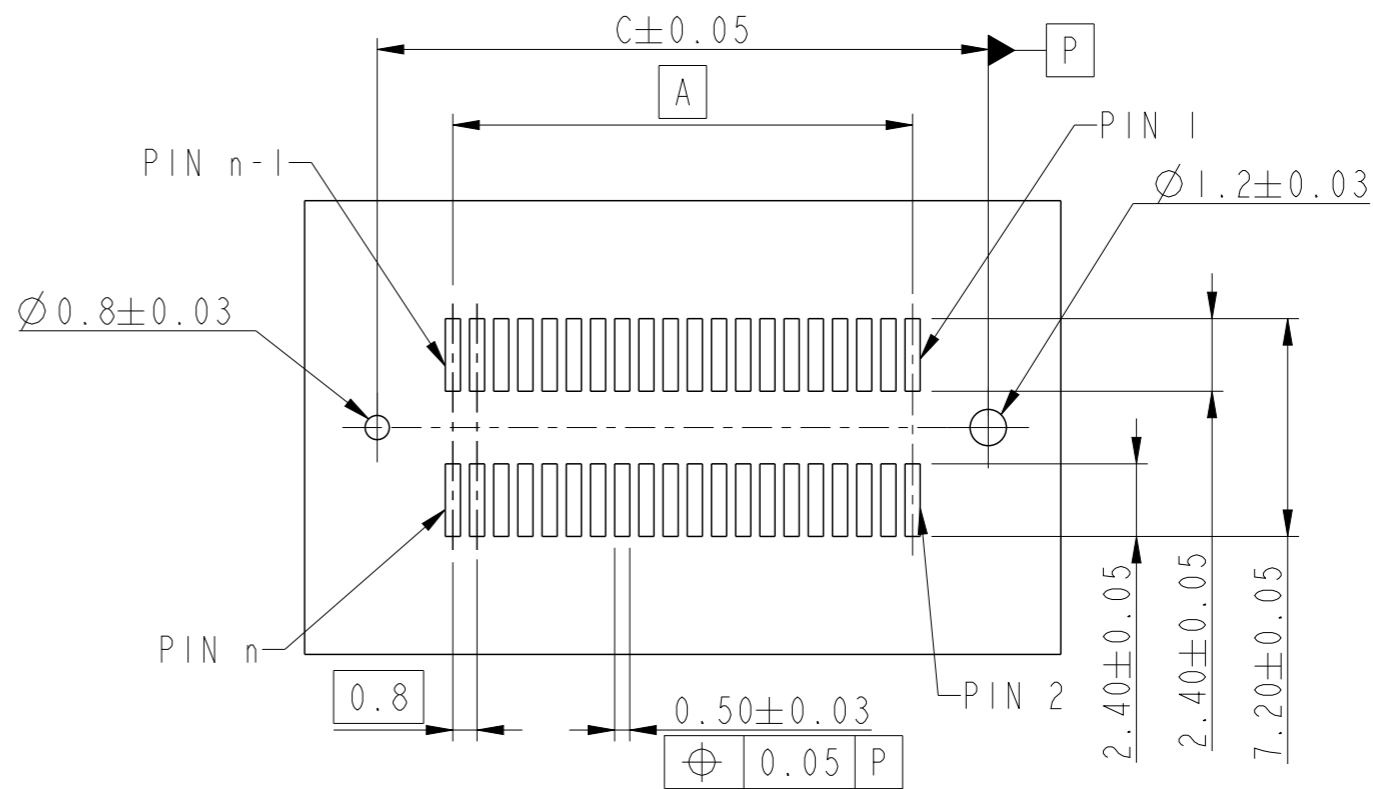

RECOMMENDED PCB LAYOUT WITH PEGS
FOR NO. OF POSITION 2X20, 2X30, 2X40, 2X50, 2X60

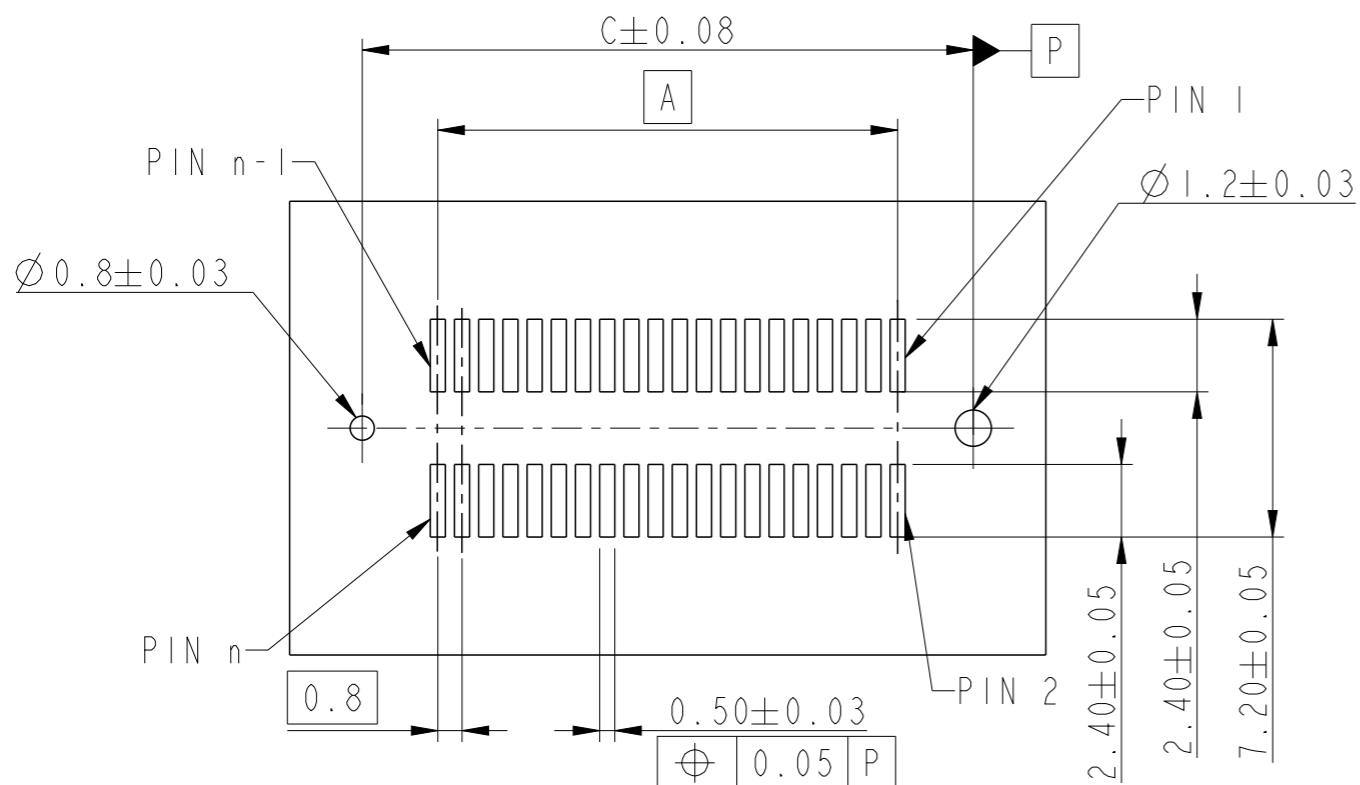

RECOMMENDED PCB LAYOUT WITH PEGS
FOR NO. OF POSITION 2X70, 2X80, 2X90, 2X100



dr	Matthew Cheong	2009/06/10	projection	MM	size	A3	scale	3:1
eng	Bob Gu	2017/04/14			ecn no ELX-N-26378-1			
chr	-	-			rel level Released			
appr	Tim Yao	2017/04/14	product family		-			
Amphenol FCI			title BERGSTAK 0.8MM RECEPTACLE ASS'Y		dwg no 61082		rev AG	
www.fci.com			cat. no. -		Product - Customer Drw		sheet 7 of 7	

X-ON Electronics

Largest Supplier of Electrical and Electronic Components

Click to view similar products for [Board to Board & Mezzanine Connectors](#) category:

Click to view products by [FCT Electronics](#) manufacturer:

Other Similar products are found below :

[10135583-642402LF](#) [89885-310LF](#) [589158040000018](#) [6-1393048-0](#) [68683-613](#) [MDF7-12DP-2.54DSA](#) [MDF7-18P-2.54DSA\(01\)](#) [MDF7-20DP-2.54DSA](#) [MDF7-26D-2.54DSA\(55\)](#) [MDF7-3P-2.54DSA\(01\)](#) [MDF7B-3P-2.54DSA\(55\)](#) [MDF7C-11P-2.54DSA\(55\)](#) [MDF7C-18P-2.54DSA\(55\)](#) [MDF7C-5P-2.54DSA\(01\)](#) [MDF7P-5P-2.54DSA\(55\)](#) [75234-0516](#) [FCN-230C068-11](#) [FCN-268F012-G/BD](#) [FCN-268F036-G/BD](#) [FCN-268M012-G/0D](#) [FCN-268M024-G/1D](#) [FCN-360C008-C](#) [FCN-360C040-C](#) [FCN-723J004/1](#) [MIS-048-01-F-D-DP-K](#) [832-10-034-10-001000](#) [93696-325LF](#) [11828-1FA](#) [AXK630345P](#) [18097-0013](#) [ICA-328STT](#) [2007042-2](#) [304400-2](#) [FCN-214Q030-G/0](#) [FCN-215Q040-G/0](#) [FCN-230C068-ESA](#) [FCN-234P048-G/0](#) [FCN-235D050-G/C](#) [FCN-360A3](#) [FCN-360C040-B](#) [210-93-314-41-105000](#) [2-22603-0](#) [379-064-521-202](#) [MDF7-12P-2.54DSA\(01\)](#) [MDF7-16P-2.54DS\(56\)](#) [MDF7-40DP-2.54DSA\(55\)](#) [MDF7-8P-2.54DSA\(55\)](#) [MDF7B-16P-2.54DSA\(55\)](#) [AXG720047](#) [5031084030](#)