

# SCM SERIES, ANGLED WIRE ENTRY PART NUMBERING SCHEME

REV	ECN	APP'D
A	4060	IQ 8/29/00
B	4241	IQ 1/2/01
C	4631	IQ 10/26/01
D	4781	IQ 3/7/02
E	4929	IQ 8/8/02
F	5742	2/12/28/05

SCM

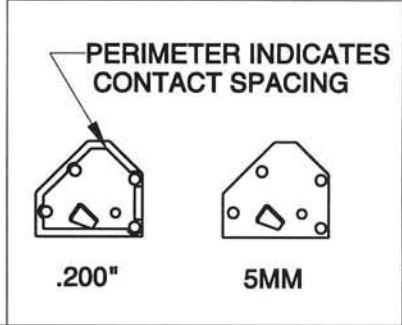
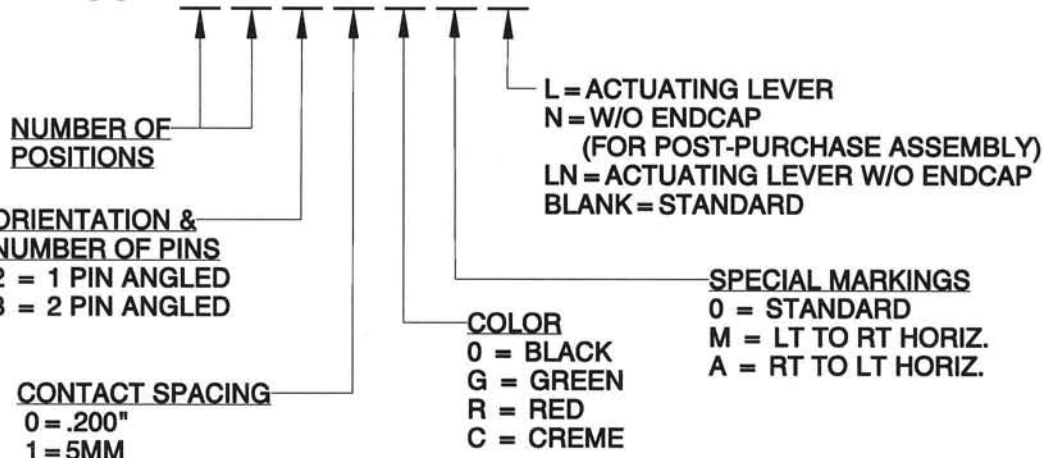

**UL RATINGS**

CURRENT - 20A  
VOLTAGE - 300V  
U.L. FILE NO. E83421

**SP RATINGS**

CURRENT - 20A  
VOLTAGE - 300 V  
CSA FILE NO. LR69703

DIN VDE 0627:1986  
DIN VDE 0110-1:1989  
EN 60947-1:1991  
EN 60947-7-1:1992

CURRENT -20A  
VOLTAGE - 300 V  
TUV FILE NO. 20396

**MATERIALS:**  
HOUSING / LEVER - NYLON, UL 94 V-0  
SPRING CLAMP - STAINLESS STEEL  
CONTACT - BRASS, TIN FINISH

**INSTALLATION RECOMMENDATIONS:**  
WIRE RANGE - #12-28 AWG, SOLID OR STRANDED  
WIRE STRIP LENGTH - .220

MAX OPERATING TEMP: 125° C

PART WITHSTANDS COMPONENT EQUILIBRIUM TEMP. OF 260° C FOR 3 MINUTES DURING SOLDERING PROCESS.

**PRINTED CIRCUIT BOARD CONFIGURATION**  
RECOMMENDED THICKNESS: .062±.008  
NOTE: ONLY ONE ROW NEEDED FOR 1 PIN CONNECTORS

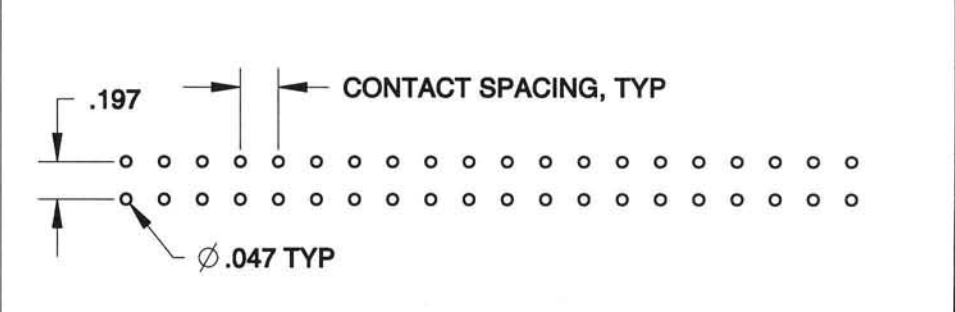

**DIMENSIONS**

ANSI Y14.5M  
UNITS: INCHES  
Pro/E FILE

**TOLERANCES**

.XX ±0.01  
.XXX ±0.002  
ANGLES ±2.0°

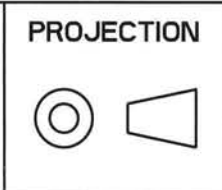

**Amphenol Pcd**

ENGR  
A. PATRIE      06-20-00

**TITLE**

SCM SERIES  
TERMINAL BLOCK ASSEMBLY  
ANGLED WIRE ENTRY

ORIGINAL  
STAMPED  
IN RED

THIS DOCUMENT CONTAINS PROPRIETARY INFORMATION WHICH IS THE CONFIDENTIAL PROPERTY OF AMPHENOL PCD, INC. PEABODY, MA, USA

CHKD  
I. QUINN      6/27/00

APPD  
J. CAHALY      7/10/00

SIZE      DWG NO.      REV

A      SCM012000      F

CODE: 58982      SCALE: NONE      SHEET 1 OF 2

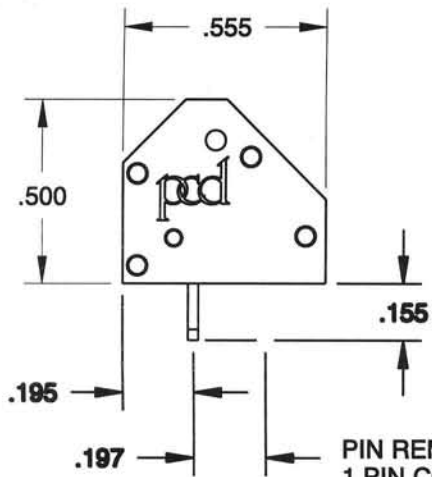

PIN REMOVED FOR  
1 PIN CONNECTOR

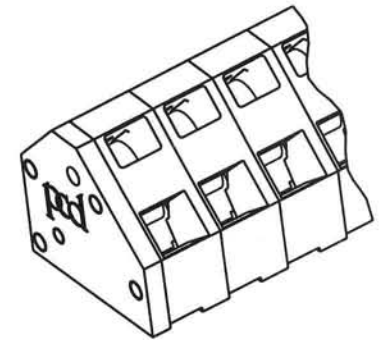
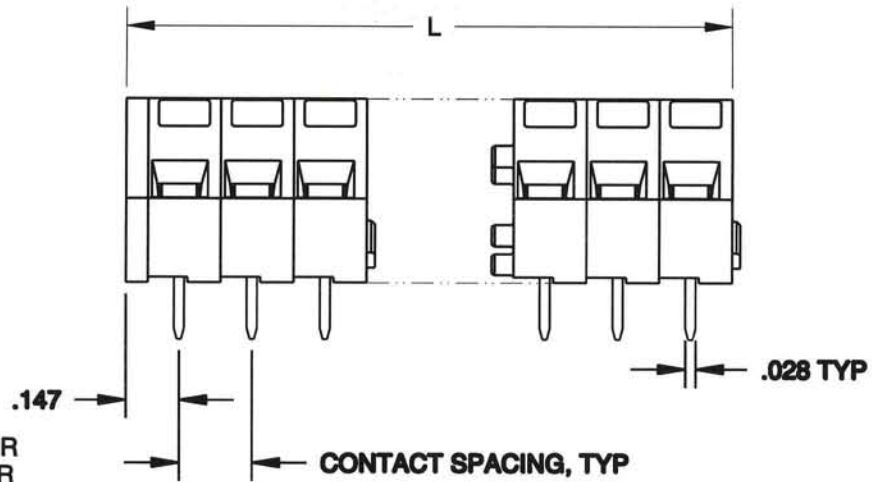

STANDARD

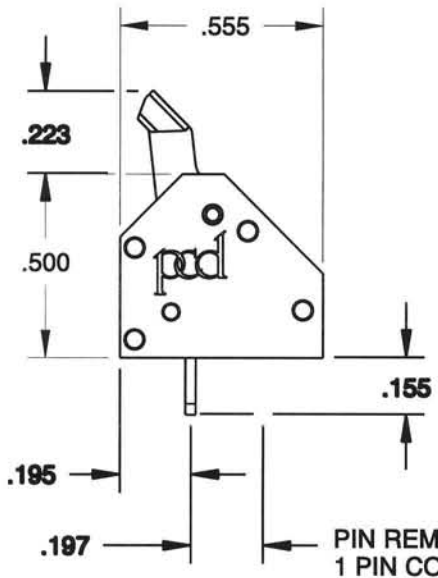

PIN REMOVED FOR  
1 PIN CONNECTOR

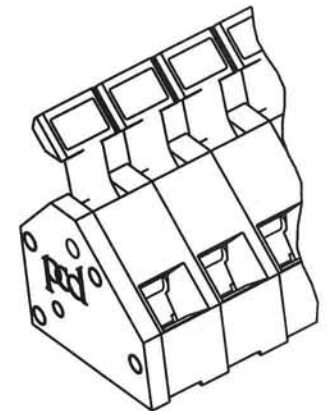
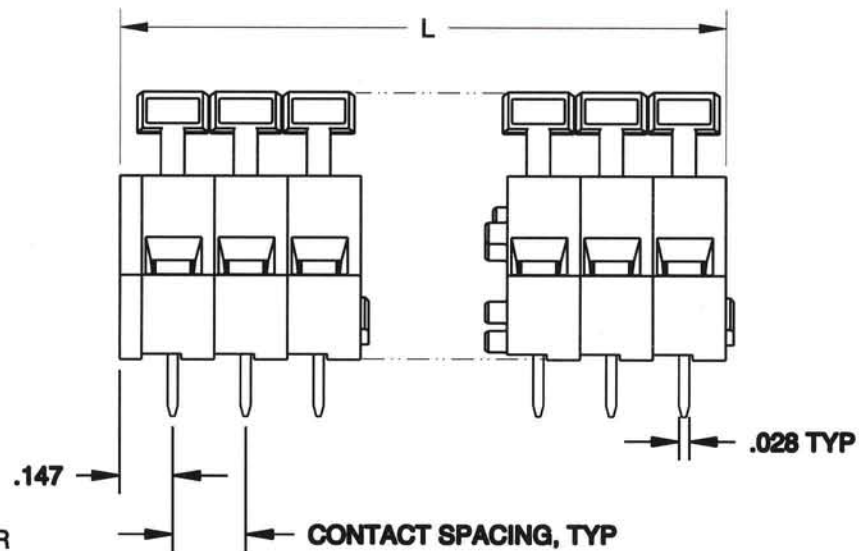

ACTUATING LEVER

L = NUMBER OF POS. X CONTACT SPACING + .060  
TYPICAL ALL CONFIGURATIONS



SIZE	DWG NO.	REV
A	SCM012000	F
CODE: 58982	SCALE: NONE	SHEET 2 OF 2

## 5.0mm (.197") SCM Wire -to- Board

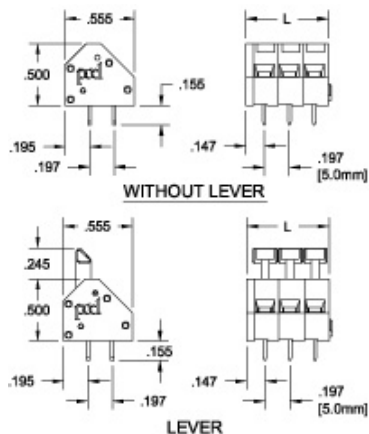
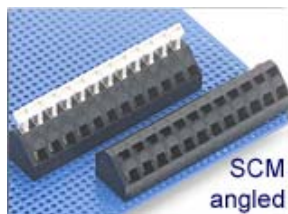

[Download part PDF File](#)

[Download part DXF File](#)

Pos	Catalog # w/o Lever	Catalog # Lever	L (mm)
2	SCM023100	SCM023100L	11.5
3	SCM033100	SCM033100L	16.5
4	SCM043100	SCM043100L	21.5
5	SCM053100	SCM053100L	26.5
6	SCM063100	SCM063100L	31.5
7	SCM073100	SCM073100L	36.5
8	SCM083100	SCM083100L	41.5
9	SCM093100	SCM093100L	46.5
10	SCM103100	SCM103100L	51.5
11	SCM113100	SCM113100L	56.5
12	SCM123100	SCM123100L	61.5
13	SCM133100	SCM133100L	66.5
14	SCM143100	SCM143100L	71.5
15	SCM153100	SCM153100L	76.5
16	SCM163100	SCM163100L	81.5
17	SCM173100	SCM173100L	86.5
18	SCM183100	SCM183100L	91.5
19	SCM193100	SCM193100L	96.5
20	SCM203100	SCM203100L	101.5

Variations

Marking

Product Line Overview

SCM 5.0mm spring clamp terminal blocks are rated at 20A/300V—the highest in the industry—and are supplied in horizontal, angled and vertical configurations.

### Two Modes of Operation

Individual spring contact clamps are depressed to insert or remove wires by either actuating a finger lever or inserting a flat-bladed screwdriver in an actuation slot on the block.

### SMT Compatibility

The SCM is the only spring clamp terminal block available which is suitable for SMT reflow solder PCB manufacturing processes as well as wave solder; providing users with additional flexibility and maximizing production efficiencies by eliminating secondary solder operations. Blocks are molded of ultra-high-temperature, glass-filled polyamide that will withstand temperatures of 260° C during PCB production.

### SPECIFICATIONS:

Current Rating: 20A  
 Operating Voltage: 300V  
 Insulation Resistance: >103 Megohms  
 Dielectric Withstanding: <1600V  
 Wire Pullout Force:  
 Per UL 486E, Section 14

### MATERIALS:

Housing/Lever: PA, UL 94V-0, black  
 Contact: Brass, tin-lead finish  
 Spring Clamp: Stainless steel

### INSTALLATION:

Wire Range: 12-28 AWG  
 Wire Strip Length: .220"  
 Hole Diameter: .047 min.

### APPROVALS:



Consult factory for specific product recognitions

[Back to Home Page](#)

© Amphenol Pcd

## **X-ON Electronics**

Largest Supplier of Electrical and Electronic Components

*Click to view similar products for [Fixed Terminal Blocks](#) category:*

*Click to view products by [Amphenol](#) manufacturer:*

Other Similar products are found below :

[00175550202](#) [MBE-1512](#) [MBE-1520](#) [MBE-154](#) [MBE-156](#) [MBES-1510](#) [MBES-153](#) [MBES-156](#) [MH-2512](#) [MHE-132](#) [MHE-133](#) [MHE-163](#)  
[MI-254 \(35\)](#) [MI-272](#) [8739](#) [880507](#) [880508](#) [MPT-275](#) [1546551-6](#) [ELM023100](#) [ELM10110G](#) [ELVD12100](#) [BA311TU](#) [BA411SU](#) [MV-152](#)  
[MV-253/NCNOC](#) [MV-254-D](#) [MV-255](#) [MV-462](#) [MV-472](#) [MV-493](#) [MVE-252](#) [MVE-253](#) [MVE-258](#) [MVE-273](#) [MVEB-153](#) [1700096](#)  
[1702246](#) [1705142](#) [1712417](#) [1713020](#) [1713088](#) [1776118-2](#) [1790852](#) [1-796689-8](#) [1-796692-6](#) [1800001](#) [1800114](#) [1823215](#) [1838462](#)