

XTR-8LR-DEC is a transceiver based on LoRa™ modulation able to guarantee ultra long range communication, high interference immunity, very high sensitivity and very low current consumption.

Compared to standard modulation techniques, “LoRa™” improves up to 20 dB the receiver sensitivity, allowing long distances by using low power transmission and very low consumption, inexpensive power supply circuits and reduced dimensions.

The receiver XTR-8LR-DEC, to be paired with Aurel transmitter XTR-8LR-DEC or with Aurel keyfob XTR-8LR-4ZN, allows to activate remote loads.

It's ideal when it has to activate and control loads at very long distance like, for example, in irrigation or alarms systems applications.

The module has 4 open collector outputs and two inputs for setting monostable or bistable output mode.

The device manages a cyclic wake up from power down mode and subsequent reception to obtain an average current consumption < 1mA useful for battery power supply application.

XTR-8LR-ENC sends an acknowledgment packet (ACK) to the paired transmitter (XTR-8LR-ENC or XTR-8LR-4ZN) with a secure encrypted RF communication.

### Main Features

- Encrypted data transmission
- Reduce dimensions ( 38.3x15.4x3.8 mm )
- UART data rate: 115200 bps
- ERP: max 20 mW
- Sensitivity -126dBm
- Power supply 3,0V
- Standard distance: 8000 m

### Applications

- Agriculture
- Irrigation Control
- Monitoring of photovoltaic plants
- Industrial controls
- SCADA
- Tele-alarms
- Monitoring of instruments

Le caratteristiche tecniche possono subire variazioni senza preavviso. AUR°EL S.p.A. non si assume la responsabilità di danni causati dall'uso improprio del dispositivo.

**Absolute maximum ratings**

Operating Temperature	-20 °C ÷ +70 °C
Storage Temperature	-40 °C ÷ +100 °C
Supply Voltage	+3,6V
Input Voltage	-1.0 ÷ V <sub>cc</sub> + 0.3V
Output Voltage	-1.0 ÷ V <sub>cc</sub> + 0.3V

**Technical characteristics**

	Min.	Typ.	Max.	Unit
<b>DC levels</b>				
Supply Voltage pin 5,14	2.1	3	3.6	V
Current consumption (Rx and power down cycle)		0.8	1	mA
Current consumption (Rx continuous) (Note 6)		16		mA
Current consumption (Tx continuous) (Note 6)		45		mA
High level voltage in input/output	0.7xV <sub>cc</sub>		V <sub>cc</sub>	V
Low level voltage in input/output	0		0.3xV <sub>cc</sub>	V
<b>Open collector output</b>				
V <sub>CE</sub> (Collector emitter voltage)			45	V
I <sub>c</sub> (DC collector current)			500	mA
<b>RF TX</b>				
Frequency		868,30		MHz
RF power		13	14	dBm
Modulation		LORA™		
Channel bandwidth -3dB		125		kHz
RF spurious emissions < 1GHz			-36	dBm
RF spurious emissions > 1GHz			-30	dBm
RF power in adjacent channel in TX (Note 2)			50	nW
Pin 1 ESD contact protection (61000-4-2)		8		kV
<b>RF RX</b>				
RX sensitivity @ 125kHz , SF 8		-126		dBm
Adjacent channel selectivity (Note3)		50		dB
Adjacent channel saturation (Note4)		87		dB
Blocking test at ±2MHz (Note 5)	85		90	dB
Blocking test at ±10MHz (Note 5)	85		94	dB
<b>Performance</b>				
UART baud rate (Note 1)		115200		bps
Bandwidth		125		kHz
Spreading Factor		8		SF
Coding Rate		4/5		
Outdoor range		8		km
RF channels		1		

Note 1: UART data is meant 8,n,1

Note2: Test carried out according to method described in ETSI EN 300 220-1 V2.4.1 paragraph 7.6

Note3: Test carried out according to method described in ETSI EN 300 220-1 V2.4.1 paragraph 8.3

Le caratteristiche tecniche possono subire variazioni senza preavviso. AUR°EL S.p.A. non si assume la responsabilità di danni causati dall'uso improprio del dispositivo.

Note4: Test carried out according to method described in ETSI EN 300 220-1 V2.4.1 paragraph 8.3.4  
 Note5: Test carried out according to method described in ETSI EN 300 220-1 V2.4.1 paragraph 8.4  
 Nota 6: Test carried out with 50 ohm load on pin 1 (antenna).

Pin description

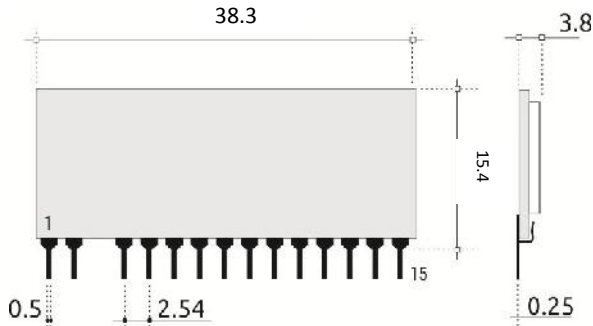

Figure 1: Pin-out and mechanical drawing

PIN-OUT

- 1) ANTENNA
- 2) GND
- 3) Not present
- 4) GND
- 5) VDD
- 6) OUT 1
- 7) OUT 2
- 8) OUT 3
- 9) OUT 4
- 10) SET 1
- 11) SET 2
- 12) BATT LOW
- 13) GND
- 14) VDD
- 15) UART TX

Pin	Name	Description
1	<b>ANTENNA</b>	Antenna connection, 50 ohm impedance.
2	<b>GND</b>	Ground connection.
3		Not present.
4	<b>GND</b>	Ground connection.
5	<b>VDD</b>	Connection to a regulated supply voltage 3V-100mA.
6	<b>OUT 1</b>	Open Collector output. See figure 2.
7	<b>OUT 2</b>	Open Collector output. See figure 2.
8	<b>OUT 3</b>	Open Collector output. See figure 2.
9	<b>OUT 4</b>	Open Collector output. See figure 2.
10	<b>SET 1</b>	Outputs mode selection.
11	<b>SET 2</b>	Outputs mode selection.
12	<b>BATT LOW</b>	Low battery output - Output active high.
13	<b>GND</b>	Ground connection.
14	<b>VDD</b>	Connection to a regulated supply voltage 3V-100mA.
15	<b>UART TX</b>	Tx data of received encoder (115200 bps)

Table 1: pin description

Le caratteristiche tecniche possono subire variazioni senza preavviso. AUR°EL S.p.A. non si assume la responsabilità di danni causati dall'uso improprio del dispositivo.

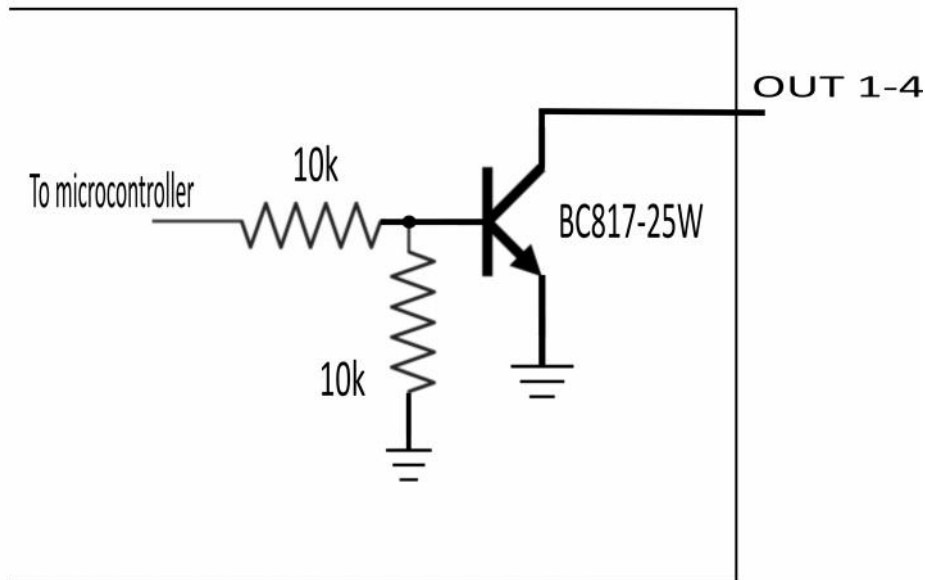

**Figure 2:** Open collector OUT 1, OUT 2, OUT 3 e OUT 4 electrical scheme

## Operation of the device

XTR-8LR-DEC, in order to cut down the average current consumption  $< 1\text{mA}$ , automatically manages a switching-on and then off cycling with dedicated duty cycle. When the device is in reception mode it verifies if a valid transmission is running and, in positive case, it remains in continuous reception for the time necessary for the decoding. The module remains active if some outputs are active in bistable mode. XTR-8LR-DEC always needs to be paired with one or more XTR-8LR-ENC or XTR-8LR-4ZN by means of learning procedure described below.

For the purposes of the present document, the following terms apply:

"Encoder": this term refers to both XTR-8LR-ENC and XTR-8LR-4ZN.

"Input activated": this term refers to XTR-8LR-ENC IN1-4 forced low and to XTR-8LR-4ZN button pressed.

The decoder can learn up 48 encoder.

When a valid data packet has been transmitted from a paired encoder, with a counter (see encoder user manual) greater than the last received (with a maximum window of 512), the related output becomes active on the decoder and the LED on board of the module shows it with a blink.

The outputs are monostable as default setting meaning that they remain active until the input of the encoder is active.

If the battery level of the encoder is under the threshold ( $< 2.4\text{V}$ ), the BATT LOW line goes active for the time of RF transmission.

XTR-8LR-DEC sends the ACK packet to the encoder with different timing in relation to the operative mode enabled on the encoder.

Le caratteristiche tecniche possono subire variazioni senza preavviso. AUR°EL S.p.A. non si assume la responsabilità di danni causati dall'uso improprio del dispositivo.

If "without retry mode" is enabled on the encoder (this mode is always active on XTR-8LR-4ZN and it is active on XTR-8LR-ENC if pin 18 RETRY EN is low), it sends packets until at least one input is active therefore XTR-8LR-DEC sends the ACK packet only when all inputs of the encoder are released.

If "with retry mode" is active on the encoder (this mode is not available for the XTR-8LR-4ZN and it is active on XTR-8LR-ENC if pin 18 RETRY EN is high), it sends only one packet (even if inputs remain active) therefore XTR-8LR-DEC sends the ACK packet immediately after the reception of a valid packet from the encoder.

### **Automatic learning procedure**

Pushing and releasing the LEARN button located on the module, it enters into learning procedure. LED blinks quickly for 10 seconds: during this time, every activation of an input on an encoder will be learned from the decoder. The positive learning of the encoder will be indicated from a switching on of the LED for 1 second. If a same encoder will be learned LED will switching on for 0,5 second. With the automatic learning procedure all inputs available on the encoder have been associated to the outputs (monostable) of the decoder.

For the learning of a new encoder, repeat this procedure.

If no encoders will be recognized in the 10 seconds learning time, the module will leave the learning procedure.

### **Manual learning procedure**

Pushing and releasing the LEARN button located on the module, it enters into learning procedure. LED blinks quickly for 10 seconds. Push again LEARN button in this time: LED will switch on permanently. Push again LEARN button for the selection of OUT1 output ( LED will blink one time for confirmation ), push again the LEARN button for the selection of OUT2 ( LED will blink twice ) and so on, up to the desired output.

Once it has been identified the desired output, activate the input of the encoder to match, then LED will blinks a number of time correspondent to the number of the output.

The output, after this learning, is monostable.

Repeat the same procedure for the learning of a new encoder or a new input of the same encoder.

## Monostable or bistable setting

In order to select the OUT1-4 outputs modes, set the SET1-2 inputs following the chart below:

SET 1	SET 2	OUT1	OUT2	OUT3	OUT4
HIGH	HIGH	MONO	MONO	MONO	MONO
HIGH	LOW	MONO	MONO	BI	BI
LOW	HIGH	MONO 1/2 sec	MONO 1/2 sec	BI	BI
LOW	LOW	BI	BI	BI	BI

MONO = monostable output: output is active until the input on the encoder is active.

BI = bistable output: each activation of the input on the encoder changes the output status.

MONO 1/ 2 Sec = monostable output: output is active per 1/2 second from when input has been released on the encoder side.

The output setting is detect only at the power on therefore for any changes of the setting it is necessary to switch off the decoder, modify SET1 and SET2 and power on again the device.

### NOTES on MONOSTABLE OUTPUT:

- if only one input is active on the encoder, the related output on the decoder is active until the input is active on encoder side;
- if two or more inputs are active on the encoder, it transmits packets with the information of the inputs status but the decoder disables all outputs.

### NOTES on BISTABLE OUTPUT:

- the output state changes when the decoder receives a packet from the encoder with the information of input active and a counter greater than the last received. Therefore, in case of input active for a long time on the encoder, the output will have only a status change because, as described in encoder user manual, the counter isn't increased. The output changes status if the input on the encoder is disabled and a new activation is done;
- if two or more inputs are active on the encoder, it sends this information and the related output status changes. For example, if IN1 is active then OUT1 will be active on the decoder. If now IN2 is activated, maintaining IN1 active, the encoder sends the information of IN1 and IN2 active and it increases the counter value. Therefore the decoder disables OUT1 and enables OUT2.

## Memory erasing procedure

Pushing and releasing the LEARN button located on the module, it enters into learning procedure.

LED blinks quickly for 10 seconds: during this time push again the button for around 5 seconds, when LED stops to blink, afterwards release the button and check the 5 blinks of LED to show the occurred memory erasing.

After device reset no encoder will be recognized and all outputs will be set according to the selected mode with SET1 and SET2 lines.

**UART data**

For each RF packet correctly received and decoded, LED on the decoder module will blink once and on UART TX line ( pin 15 ) will be transmitted data, related to the encoder received, as showed below:

**LSB**

**MSB**

Serial				Synchronization counter					
ID Low (8 bit)	ID Mid Low (8 bit)	ID Mid High (8 bit)	ID Hi (bits 7-4) + Button Key (bits 3-0)	Voltage Level (bits 1-0) Counter frame (bits 2-3)	Synchr Low (8 bit)	Synchr Mid (8 bit)	Synchr High (8 bit)		

**Serial:** is the 28 bits serial unique identifier of the encoder.

**Button Key:** IN1-4 lines status of the encoder or buttons status in case of keyfob:

Input encoder	Keyfob	Button Key (bit 3-0)
IN1 low	Button 1	1110
IN2 low	Button 2	1101
IN3 low	Button 3	1011
IN4 low	Button 4	0111

**Voltage Level:** is the battery level indication (2 bit):

Voltage Level (bit 1-0)	Battery level (Volt)
00	Voltage <= 2.3
01	2.3 < Voltage <= 2.7
10	2.7 < Voltage <= 3.0
11	Voltage > 3.0

**Counter frame:** is a 2 bits counter of the transmitted frames.

**Synchronization counter:** is the 24 bits encoder counter, it is increased when there is a change in the input status of the encoder (see encoder user manual).

## DEVICE USAGE

In order to obtain the performances described in the technical specifications and to comply with the operating conditions which characterize the certification, the transceiver should be mounted on a printed circuit taking into account the following:

### Power Supply:

1. XTR-8LR-DEC must be supplied from very low voltage safety source protected against the short circuits. maximum voltage variations allowed:  $2.1 \div 3.6$  V. However it is preferable to maintain a stable voltage to a predetermined value in the range of voltage as specified above, using a "fast transient response" voltage regulator.
2. Decoupling, close to the transceiver, with a ceramic capacitor of minimum 100nF.
3. Connect electrolytic capacitor 100uF, low ESR, close to pins 5,14 (VDD).

### Input pin interface:

Put 100pF capacitors close to the corresponding input pins, connected between them and the ground plane.

### Ground:

The ground must surround at the best the welding area of the module and must also be realized in the lower face of the PCB in order to obtain the optimal result, with the through holes connecting the two ground planes.

### Antenna:

Connect pin 1 (antenna) to the coaxial connector or antenna, with 50 ohm constant impedance microstrip; width 3.2 mm for PCB with thickness 1.6 mm and width 1.6 mm for PCB with thickness 1mm.

The antenna is a typical rigid copper wire (insulated or not) of 8cm length and cross-section at least of 0.5 mm<sup>2</sup> placed vertically to the ground plane. Other placements of antenna (bend, coil) will work but performance are not predictable.

As an alternative to connect the module to an external antenna, connect an SMA connector into PCB using 50 ohm microstrip.



## Reference Rules

XTR-8LR-DEC transceiver is compliant with the european set of rules **EN 300 220-2**, and **EN 301 489-3**. The transceiver must be supplied by a very low voltage safety source protected against short circuits. The usage of the module is foreseen inside enclosures that guarantee the **EN 61000-4-2** normative not directly applicable to the module itself. This device is compliant with **EN 62479** connected to the electromagnetic field human exposition if used with temporal duty cycle not higher than 1% like foreseen in CEPT 70-03 recommendation.

## CEPT 70-03 Recommendation

XTR-8LR-DEC recommendation is referred to the 868.0 - 868.6 MHz harmonized bandwidth and therefore, in order to comply with local regulations, the device must be used on the time scale with maximum duty-cycle time of 1% (equivalent to 36 seconds of usage on 60 minutes).

## Revision:

Release date	Revision user manual	Firmware version	Changes from the previous revision
28/11/2016	1.0	0403	Preliminary
16/02/2017	2.0	0405	First release

## X-ON Electronics

Largest Supplier of Electrical and Electronic Components

*Click to view similar products for [RF Modules](#) category:*

*Click to view products by [Aurel](#) manufacturer:*

Other Similar products are found below :

[HMC-C009](#) [HMC-C011](#) [nRF24L01P-MODULE-PCB](#) [HMC-C021](#) [HMC-C024](#) [XB9XT-DPRS-721](#) [XBP9B-DMUTB022](#) [nRF24L01P-MODULE-SMA](#) [CMD-KEY2-418-CRE](#) [XM-C92-2P-UA](#) [XB9XT-DPUS-721](#) [V640-A90](#) [HMC-C583](#) [MAAM-008818-TR3000](#) [MTSMC-H5-U](#) [SIMSA868-PRO](#) [SIMSA915C-PRO](#) [SIMSA868C-PRO](#) [SIMSA433C-PRO](#) [SIMSA915-PRO](#) [XBP9B-DMUT-042](#) [HMC-C582](#) [HMC-C022](#) [XBP9B-DPST-041](#) [XBP9B-DMWT-042](#) [SM-MN-00-HF-RC](#) [HMC-C031](#) [MT-02](#) [M1002GB](#) [702-W](#) [SIMSA868C-N-PRO](#) [SIMSA433C-N-PRO](#) [SIMSA915C-N-PRO](#) [ADP-R202-00B](#) [PEPPER WIRELESS C1 USB](#) [S2-10732-Z1T61](#) [S2-107XB-Z2356-Z2352](#) [S2-10672-Z1L85](#) [S2-10686-Z1L1D](#) [S2-10688-Z1L1T](#) [S2-106BA-Z1P20](#) [S2-1060C-Z1F0A](#) [S2-106R4-Z1Q6F-Z1Q6Q](#) [S2-106R4-Z1Q6J-Z1Q6Q](#) [S2-106RB-Z1Q6V-Z1Q6Q](#) [S2-107DR-Z1Y5B](#) [SU60-2230C-PU](#) [RC-TFSK3-868](#) [NANO RFID POE](#) [RFID USB POCKET](#)