

Ref. CCT15450 - CCT15451
CCT15452 - CCT15453



IHP



Schneider
Electric

Cable

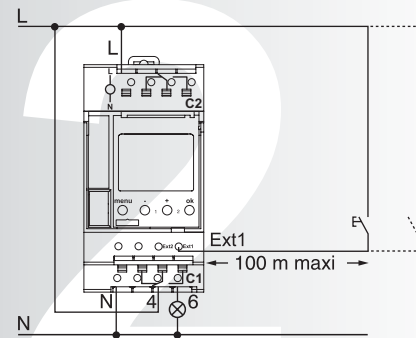

Note:

The external input operating mode is defined in the chapter "Adapt the configuration".

Discover your IHP

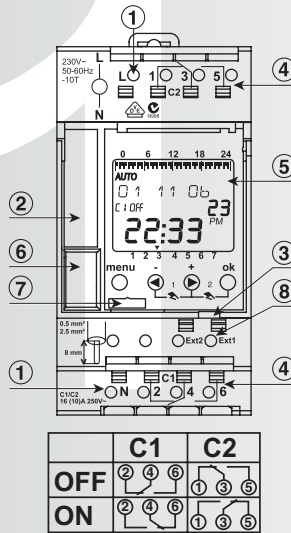

	C1	C2
OFF	② ④ ⑥	① ③ ⑤
ON	② ④ ⑥	① ③ ⑤

- ① 230 V AC supply +10 %, -15 %, 50/60 Hz
- ② Leaflet-holder
- ③ Sealable cover
- ④ Output contacts
- ⑤ LCD screen (back-lit on cat. nos. CCT15451 and CCT15453)
- ⑥ Programming key storage
- ⑦ Programming key connector (only cat. nos. CCT15451 and CCT15453)
- ⑧ External control input only for cat. nos. CCT15451 and CCT15453 (Ext 1 for channel 1 and Ext 2 for channel 2)

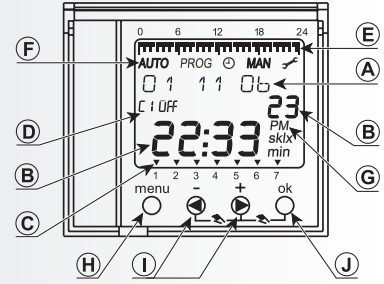

- A(B)(C) Date, Time, Day (Day 1 = Monday by default)
 - D Output contact status display (alternating C1/C2 for cat. nos. CCT15452 and CCT15453)
 - E Viewing On periods per 30-minute segment
 - F Operating mode: "AUTO", "PROG": programming, "⌚": time setting, "MAN": programming Holiday, Time Delay and Random functions for cat. nos. CCT15451 and CCT15453, "🗓️": adapt the configuration
 - G "PM": afternoon
 - H "Menu": select the operating mode
 - I "-", "+": value setting and navigation keys
 - J "ok": flashing information validation key
- Reset by pressing simultaneously the 4 keys "+", "-", "Menu" and "ok" i.e. (H)(I) and (J).

Configure

On energisation or once you have carried out a Reset (see Discover chapter):

- Choose the language (French, English, etc.).
- Choose to delete or to keep the program existing in the product.
- Set the year, month, day and time.
- Choose the summer/winter time changeover parameters.

Once this phase is completed, your IHP will move to the "AUTO" mode and operate with the elements defined opposite.

If you do not agree with the flashing value or word: scroll up and down the display using the "-" and "+" keys.
To confirm the flashing value or word: validate with "ok".
If you are lost: press "Menu" to return to the "AUTO" mode without saving the last modification.
If you do not press a key for 2 minutes: your IHP will move to the "AUTO" mode and operate with the elements defined opposite.

Zone	Summer time	Winter time	Comments
EUROPE	Last Sunday in March at 2 a.m.	Last Sunday in October at 3 a.m.	
GB/IRL/P	Last Sunday in March at 1 a.m.	Last Sunday in October at 2 a.m.	Great Britain - Portugal
FIN/GR/TR	Last Sunday in March at 3 a.m.	Last Sunday in October at 4 a.m.	Finland - Greece - Turkey
CDN	First Sunday in April at 2 a.m.	Last Sunday in October at 3 a.m.	Canada
FREE RULE	As per choice	As per choice	Choice of month, week, day (Monday, Tuesday, etc.) and time
FIX DATE	As per choice	As per choice	Choice of month, date (01, 02...) and time
NONE	-	-	

Program your IHP "PROG"

The IHP allows you to program 2 types of control: switching operations (On / Off) and pulses (On / Off, on IHP+ products cat. nos. CCT15451 and CCT15453).

To create an operating period: program an On switching followed by an Off switching. The "COPY" function allows you to repeat the created switching operation or pulse for other days of the week and save memory space (creation of a "block"). Access the "PROG" mode by pressing the "Menu" key; you now have 5 possibilities:

- "NEW": to build the program and enter it in the memory.
- "CHECK": to view the program.
- "MODIFY": to update the program already in the memory. If the transition selected to be modified is repeated on other days of the week, the product proposes "MODIFY BLOCK", this function lets you modify all identical transitions (type and time).
- "DELETE": to delete part of or the whole of the program (date, time and choice of language are kept). If the transition selected to be deleted is repeated on other days of the week, the product proposes "DELETE BLOCK", this function lets you delete all identical transitions (type and time).
- "END": to leave the "PROG" mode.

Date / Time "⌚"

Modify the time, date, summer/winter time, day of the week, time format, date format.

Press "Menu", access the mode "⌚" using the "+" key:

- Change the time and date.
- Choose summer/winter time (see the table in the "Configure" chapter).
- Define the 1st day of the week (for example Monday for Europe).
- Modify the format of the date "FORM DATE":
 - D / M / Y
 - M / D / Y
 - Y / M / D.
- Modify the format of the time "24h / 12h":
 - 24h display
 - 12h display.

Manual mode "MAN"

In this mode you can:

- Program a holiday period "HOLIDAY" (temporarily cancel **On** periods by configuring start and end of absence dates and times).
- On cat. nos. CCT15451 and CCT15453, you can also:
 - modify for an adjustable duration, operation (**On** or **Off** on channel) from the current time "TIMER"
 - use the product in random mode "RANDOM" (to carry out presence simulation).

To carry out one of these operations, you must: press "Menu", access the "MAN" mode via the "+" key.

■ "HOLIDAY": there are four different operation types in this Holiday mode:

- "ON": output activated
- "OFF": output de-activated
- "RANDOM1": random operation in a fixed **On** range
- "RANDOM2": **On** operation in a range with a random start and end.

Once you have defined the type of operation, you must enter the start and end of absence dates.

■ "TIMER": to define the status of the waiver and its duration.

■ "RANDOM":

- "RANDOM1"
- "RANDOM2"

Its operation is identical to the Holiday mode, but without limitation in duration.

ON-OFF override "Channel 1, Channel 2"

■ **Activate ON override or OFF override** (until the next switching operation) by pressing simultaneously both keys " " for C1 or " " for C2 for less than 2 s. The output contact changes status:

- the IHP indicates by "C1 OVERRID" or "C2 OVERRID" the new status of the output contact
- return to the automatic mode by pressing both these keys for less than 2 s.

■ **Move to permanent ON or permanent OFF** by pressing simultaneously both keys " " for C1 or " " for C2 for more than 2 s: each time you press a key for more than 2 s, the output contact changes status:

- the IHP indicates by "C1 PERM" or "C2 PERM" the new status of the output contact
- return to the automatic mode by pressing both these keys for less than 2 s.

■ **The IHP also allows external override by an external pushbutton or switch, cabled on the terminal (reference 8), cat. nos. CCT15451 and CCT15453):**

permanent **On** or **Off** override by external input (switch) takes priority over the ON – OFF override function of the product.

For configuration of the external input, see "Adapt the configuration".

Electronic key (cat. no. CCT15861)

■ You have an electronic key to facilitate programming of your IHP. The key should:

- be placed in its compartment (beneath the "Menu" and "-" keys) if you use it
- be placed under the leaflet-holder when it is not used.

Before placing your electronic key, set the product to "Auto".

Insert the electronic key and a specific menu will appear.

△ **Installation of the electronic key inhibits the "Menu" and "-" keys. To move and validate, you must use "+" and "OK".**

- "COPY KEY → TSWI": to copy the electronic key program to your IHP.
- "COPY TSWI → KEY": to copy the IHP program to the electronic key.
- "RUN KEY": to operate the IHP with the programming memorised in the electronic key, without program transfer.
- "CHECK KEY": to read the content of the electronic key, each programming step is then displayed by pressing the "+" key. Press "OK" to return to the main menu.
- "END": to remove the electronic key.

An electronic key programming kit (cat. no. CCT15860) including a PC/electronic key interface, a lead, an electronic key and a programming software lets you program your electronic key directly from a PC.

Load table

■ Permissible output contact power:

- resistive loads: I max. = 16 A - 250 V~, I min. = 200 mA - 12 V~
- motors: 2300 VA.

Lighting type/load	Max. power
resistive load (cos φ = 1)	16 A
inductive load (cos φ = 0.6)	10 A
incandescent (230 V)	2300 W
halogen (230 V)	2300 W
series corrected / non-corrected, fluorescent	26 x 36 W, 20 x 58 W, 10 x 100 W
parallel-corrected, fluorescent, with conventional ballast	10 x 36 W (4,7 μF), 6 x 58 W (7 μF), 2 x 100 W (18 μF)
dual-mounted, fluorescent	10 x (2 x 58 W), 5 x (2 x 100 W)
fluorescent, with electronic ballast	9 x 36 W, 6 x 58 W
dual-mounted, fluorescent, with electronic ballast	5 x (2 x 36 W), 3 x (2 x 58 W)
fluo-compact, with electronic ballast	9 x 7 W, 7 x 11 W, 7 x 15 W, 7 x 20 W
parallel-corrected, mercury vapour, fluorescent	1 x 250 W (30 μF)
parallel-corrected, sodium vapour	1 x 250 W (37 μF)

For the other applications, relay using a CT contactor.

Adapt the configuration " "

In this mode, you can:

■ **View the counter indicating output operating time** and, if you want, reset this counter.

■ **Define the type of external input** (this choice must be made in keeping with the element cabled to the product) and its operating mode (only on cat. nos. CCT15451 and CCT15453). There are three possible choices:

- NOT ACTIVE
- BUTTON
- SWITCH.

Once the type is defined, you must define the operating mode:

- for the pushbutton:
 - OVERRIDE: temporary forcing until the next switching operation
 - TIMER: press to start a time delay for a set period of time. This time delay is possible in **On** or **Off** mode at output level.
- for the switch:
 - permanent **On**
 - permanent **Off**
 - blocking.

For the first two choices, the switch is open in normal operation and its closure results in an **On** or **Off** at the output. For the third choice, the switch is closed in normal operation and its opening imposes an **Off** (relay open) at the output.

■ **Define operation of LCD illumination** (only on cat. nos. CCT15451 and CCT15453).

- there are two choices:
 - after 1 min off: lighting goes off 1 min after the last time one of the front face keys is pressed
 - always on.

■ **Modify language.**

■ **Return to the product initialisation phase** ("Configure" chapter).

To perform one of these operations you must: press "Menu", access the " " mode using the "+" key.

■ **"OPERATING HOUR":** access the "output activated" counter:

- "SHOW HOUR": read the counter
- "DELETE": reset the counter.

■ **"EXT INPUT":** to define the input type and operation.

■ **"LCD-ILLUMINATION":**

- "AFTER 1 MINUTE OFF": lighting goes off 1 minute after the last time a key is pressed
- "ALWAYS ON".

■ **"LANGUAGE".**

■ **"FACTORY SETTINGS".**

Technical data

- Consumption:
 - 1 channel max. 4 VA
 - 2 channels max. 7 VA
- Memory: 56 switching operations except cat. nos. CCT15451 and CCT15453, 84 switching operations
- Minimum time between two switching operations: 1 minute
- Back-up of program and time by lithium battery: operating reserve: 6 years.
- Operating temperature: -25°C to +45°C
- Insulation class: II as per EN 60730-1 in installed state
- Degree of protection: IP20B as per EN 60529
- Connection terminals: 2 x 0.5 to 2.5 mm², rigid and flexible wires
- Overall dimensions: 5 modules

External input

- Voltage: 230 V~ +10 %, -15 %
- Frequency: 50/60 Hz
- Input current: max. 1.2 mA
- Consumption: max. 0.3 W
- Cable length: max. 100 m.

X-ON Electronics

Largest Supplier of Electrical and Electronic Components

Click to view similar products for [Timers](#) category:

Click to view products by [Schneider](#) manufacturer:

Other Similar products are found below :

[79237785](#) [H3DS-GL AC24-230/DC24-48](#) [H5AN-4DM DC12-24](#) [H5CN-XDNM AC100-240](#) [H5CN-YAN AC100-240](#) [H5CX-L8S-N AC100-240](#) [H3AMNSCAC100240](#) [H3AM-NSR-B AC100-240](#) [H3CA-8 DC12](#) [H3CR-A8-302 DC24](#) [H3CR-F AC24-48/DC12-48](#) [H3CR-G8EL AC200-240](#) [H5AN-4D DC12-24](#) [81506944](#) [88225029](#) [H5S-YB4-X](#) [H3CR-A-301 AC100-240/DC100-125](#) [H3CR-AS AC24-48/DC12-48](#) [H3DK-GE AC240-440](#) [H3RN-2 AC24](#) [H3RN-21 AC24](#) [H3CR-H8RL AC/DC24 M](#) [H3CR-H8RL AC100-120 S](#) [H3CR-G8EL-31 AC100-120](#) [H3CR-H8RL AC100-120 M](#) [H3CR-HRL AC100-120 M](#) [H3CR-A8-301 AC24-48/DC12-48](#) [H3CR-H8RL AC/DC24 S](#) [H7AN-2D DC12-24](#) [H5CN-XANS DC12-48](#) [H3CA-8 DC110](#) [H7AN-W4DM DC12-24](#) [H7AN-4DM DC12-24](#) [H7AN-4D DC12-24](#) [H7AN-RT6M AC100-240](#) [H3CA-8H AC200/220/240](#) [MTR17-BA-U240-116](#) [PM4HSDM-S-AC240VS](#) [PM4HSDM-S-AC240VSW](#) [PO-405](#) [600DT-CU](#) [H3Y-2-B DC24 30S](#) [PM4HF8-M-DC24V](#) [PM4HS-H-DC12VSW](#) [H3Y-2-B AC100-120 10S](#) [H3Y-2-B AC100-120 30S](#) [H3C-R](#) [H3CR-A8-301 24-48AC/12-48DC](#) [H3CR-A8E 24-48AC/DC](#) [H3CR-F8 100-240AC/100-125DC](#)