

### FEATURES

- CLASS I DIELECTRIC, TEMPERATURE COMPENSATING
- HIGH STABILITY OVER TIME, VOLTAGE AND TEMPERATURE CHANGES
- LOW DIELECTRIC LOSS
- NICKEL BARRIER TERMINATIONS AND EXCELLENT MECHANICAL STRENGTH

**Expanded  
01005  
Case Size**

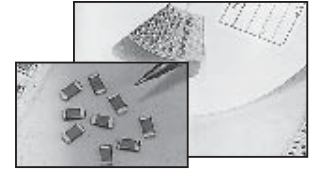

### SPECIFICATIONS NPO

Capacitance Range	0.47pF to 0.068μF
Capacitance Tolerance	Below 10pF: ±0.1pF(B), ±0.25pF(C), ±0.5pF(D) 10pF and above: ±1%(F), ±2%(G), ±5% (J)
Operating Temperature Range	-55°C ~ +125°C
Temperature Characteristics	0 ± 30ppm/°C
Rated Voltages	25Vdc, 35Vdc, 50Vdc (see NMC-H Series for higher voltages)
Dissipation Factor	For values >30pF 0.1% @ 25°C; For values ≤ 30pF Q=400+20 x C (C in pF)
Insulation Resistance	10,000Megohms min. or 500Megohm/μF (min.), whichever is less @ +25°C
Dielectric Withstanding Voltage	250% of Rated Voltage for 5 ± 1 seconds, 50mA maximum current
Test Conditions (EIA-198-2E)	<1000pF; 1MHz, 1.2Vrms max. or >1000pF; 1KHz, 1.2Vrms max.

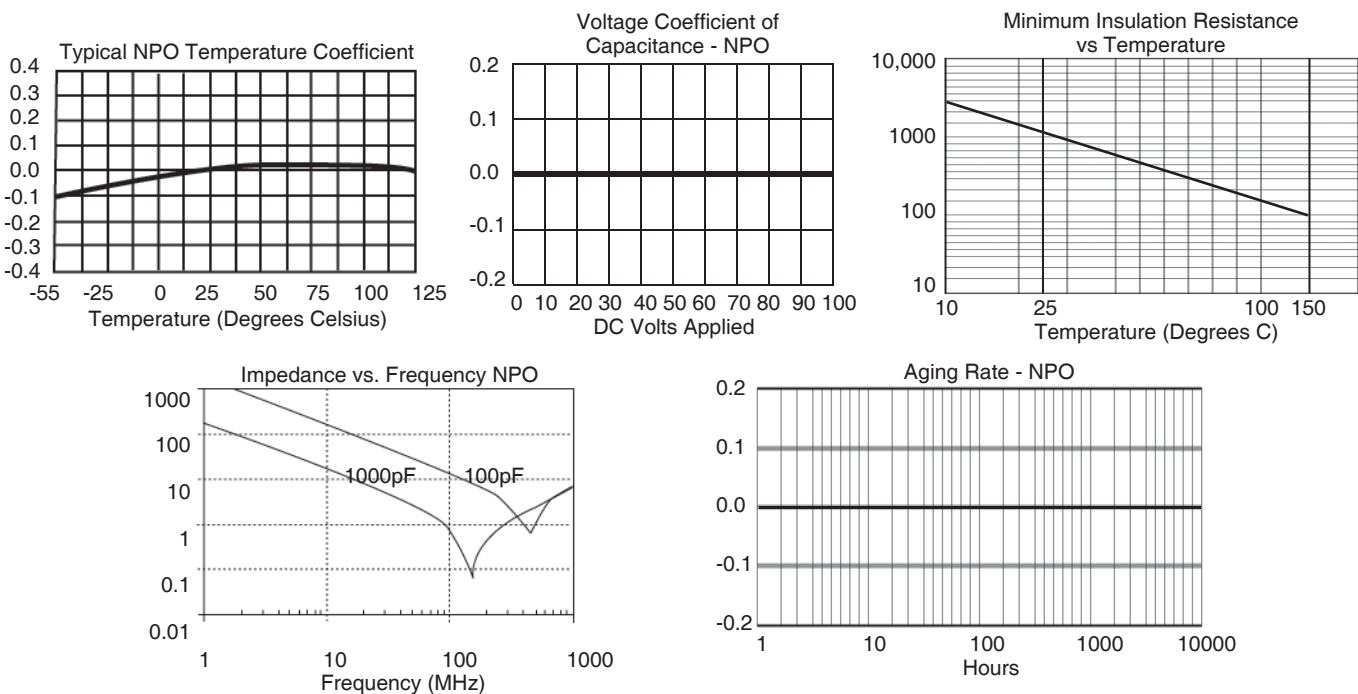

### PART NUMBER SYSTEM

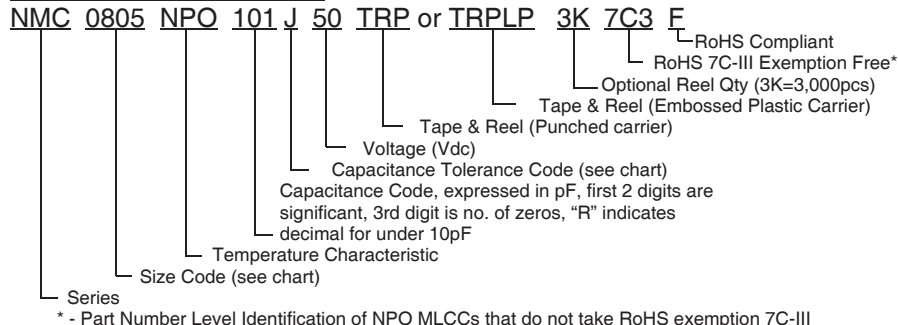

# Multilayer Ceramic Chip Capacitors

NMC Series NPO

EIA Case Size	01005
Length (L)	0.4±0.02
Width (W)	0.2±0.02
Thickness max. (T)	0.22
Termination Width (P)	0.1±0.03
Capacitance	Working Voltage (Vdc)
	16
0.5pF	
1.0pF	
1.5pF	
2.0pF	
3.0pF	
4.0pF	
5.0pF	
6.0pF	
7.0pF	
8.0pF	
9.0pF	
10pF	
12pF	
15pF	
18pF	
22pF	
27pF	
33pF	
39pF	
47pF	
56pF	
68pF	
82pF	
100pF	

EIA Case Size	0201		0402				0603				0805					
Length (L)	0.6±0.03		1.0±0.05				1.6±0.15				2.0±0.2					
Width (W)	0.3±0.03		0.5±0.05				0.8±0.15				1.25±0.2					
Thickness max. (T)	0.33		0.6				1.0				1.35					
Termination Width (P)	0.15±0.05		0.2±0.1				0.12 ~ 0.51				0.25 ~ 0.71					
Capacitance	Working Voltage (Vdc)															
	10	16	25	50	16	25	50	100	16	25	50	100	16	25	50	100
0.47pF ~ 22pF																
24pF																
27pF																
30pF																
33pF																
36pF																
39pF																
43pF																
47pF																
51pF																
56pF																
62pF																
68pF																
75pF																
82pF																
91pF																
100pF																
110pF																
120pF																
130pF																
150pF																
160pF																
180pF																
200pF																
220pF																
240pF																
270pF																
300pF																
330pF																
360pF																
390pF																
430pF																
470pF																
510pF																
560pF																
620pF																
680pF																
750pF																
820pF																
910pF																
0.001µF																
0.0012µF																
0.0015µF																
0.0018µF																
0.0022µF																
0.0027µF																*
0.0033µF																*
0.0039µF															*	*
0.0047µF															*	
0.0056µF														*	*	
0.0068µF														*	*	
0.0082µF														*	*	

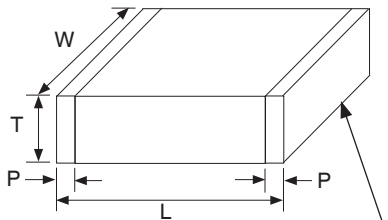

100% Sn over Ni barrier  
(CONSULT FACTORY FOR CAPACITANCE VALUES NOT LISTED)

\*1.45mm maximum thickness



EIA Case Size	0805				1206				1210				1812			2225				
Length (L)	2.0±0.2				3,2±0.2				3.2±0.2				4.5±0.3			5.70±0.4				
Width (W)	1.25±0.2				1.6±0.2				2.5±0.2				3.2±0.25			6.35±0.25				
Thickness max. (T)	1.45				1.80				1.80				1.80			1.80				
Termination Width (P)	0.25 ~ 0.71				0.25 ~ 0.71				0.25 ~ 0.71				0.25 ~ 0.76			0.25 ~ 1.02				
Capacitance	Working Voltage (Vdc)																			
	16	25	50	100	10	16	25	50	100	10	16	25	50	100	25	50	100	50	100	
0.47pF ~ 9.1pF																				
10pF ~ 22pF																				
24pF ~ 0.001µF																				
0.0012µF																				
0.0015µF																				
0.0018µF																				
0.0022µF																				
0.0027µF																				
0.0033µF																				
0.0039µF																				
0.0047µF																				
0.0056µF																				
0.0068µF																				
0.0075µF																				
0.0082µF																				
0.0091µF																				
0.01µF																				
0.012µF																				
0.015µF																				
0.018µF																				
0.022µF																				**
0.027µF																				**
0.033µF																				**
0.039µF																				**
0.047µF																				
0.056µF																				

\*1.90mm maximum thickness, \*\*2.60mm maximum thickness

**See NMC High Capacitance datasheet for higher capacitance values  
or NMC-H High Voltage datasheet for higher voltage ratings**



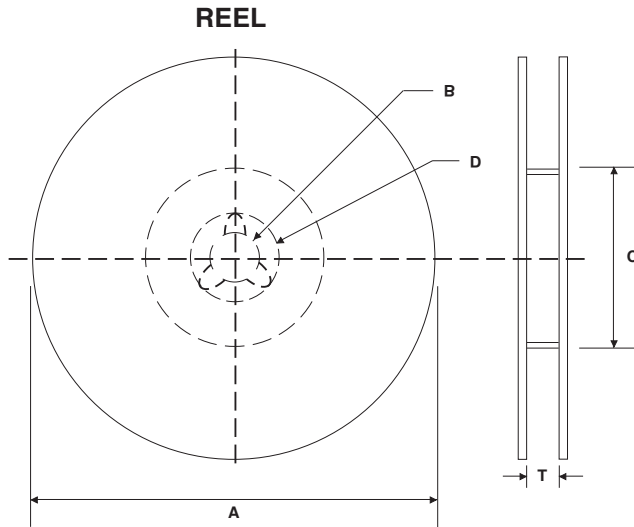

### REEL DIMENSIONS (mm)

Reel Diameter (A)	B	C	D	T max.
7" (178 ± 2.0)	13 ± 0.5	50 min.	21 ± 1.0	8.4 +1.0/-0 (1812 case size 12.4 +2.0/-0)
10" (250 ± 2.0)		100 ± 1.0		
13" (330 ± 2.0)		100 ± 1.0		

### 7 INCH REEL QUANTITIES\*

Size	01005	0201	0402	0603	0805	1206	1210	1812
Tape Size	8mm	8mm	8mm	8mm	8mm	8mm	8mm	12mm
Min. Qty Per Reel	20,000	20,000	10,000	4,000	4,000	4,000	2,000	1,000
Max. Qty Per Reel	20,000	20,000	10,000	4,000	5,000	5,000	5,000	2,000

\*Quantity dependent on chip thickness. Contact NIC for reel quantities on larger diameter reels.

### CARRIER TAPE MATERIAL

Parts with a thickness of ≥1mm will be taped on embossed plastic carrier. Parts with a thickness of less than 1mm will be taped on paper carrier

### EMBOSSED PLASTIC CARRIER TAPE DIMENSIONS (mm)

Tape Size	W	F	E	P <sub>0</sub>	P <sub>2</sub>	D	K max.	T max.	P
8mm	8.0 ± 0.2	3.5 ± 0.05	1.75 ± 0.10	4.0 ± 0.1	2.0 ± 0.5	1.5 <sup>+0.1</sup> <sub>-0.0</sub>	3.0	2.0	4.0 ± 0.1
12mm	12 ± 0.2	5.5 ± 0.05						4.5	8.0 ± 0.1

#### Notes:

- Specifications are in compliance with EIA RS481-1-A "Taping of surface Mount Components for Automatic Placement"
- Dimensions A<sub>0</sub> (max.) equals component width dimension plus 0.5mm
- Dimension B<sub>0</sub> (max.) equals component length dimension plus 0.5mm

### EMBOSSED PLASTIC CARRIER TAPE

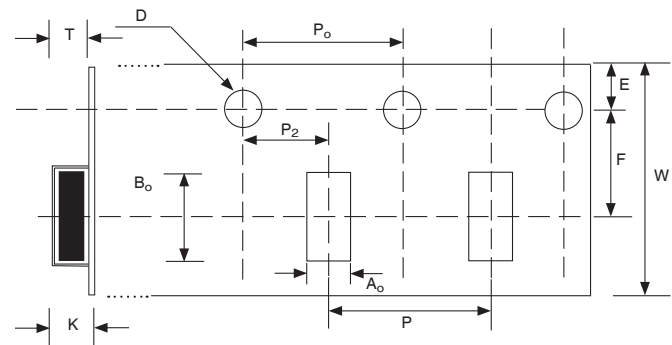

See notes 2 & 3 regarding dimensions A<sub>0</sub> and B<sub>0</sub>

### PUNCHED CARRIER TAPE DIMENSIONS (mm)

Type	A <sub>0</sub>	B <sub>0</sub>	W	F	E	P1	P0	D0	T1 max.	T2 max.	Mounting Hole
01005	0.25 ± 0.04	0.45 ± 0.04	8.0 ± 0.3	3.5 ± 0.05	1.75 ± 0.1	2.0 ± 0.05	4.0 ± 0.1	1.5 <sup>+0.1</sup> <sub>-0.0</sub>	0.27	0.36	Angular Punch Hole
0201	0.37 ± 0.03	0.67 ± 0.05							0.45	0.80	
0402	0.65 ± 0.05	1.15 ± 0.05							1.1	1.4	
0603	1.1 ± 0.2	1.9 ± 0.2				4.0 ± 0.10			1.1	1.4	
0805	1.65 ± 0.2	2.4 ± 0.2									
1206	2.0 ± 0.2	3.6 ± 0.2									

### PUNCHED CARRIER TAPE

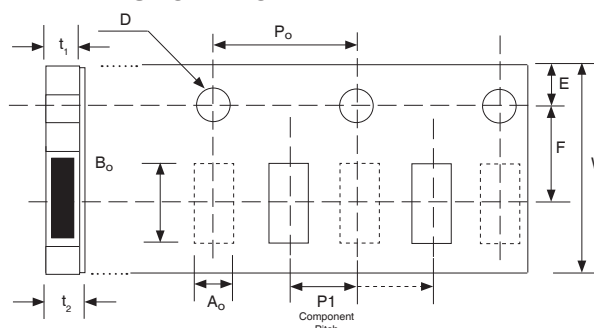

## X-ON Electronics

Largest Supplier of Electrical and Electronic Components

*Click to view similar products for [Multilayer Ceramic Capacitors MLCC - SMD/SMT](#) category:*

*Click to view products by [NIC](#) manufacturer:*

Other Similar products are found below :

[M39014/01-1467](#) [M39014/02-1218V](#) [M39014/02-1225V](#) [M39014/02-1262V](#) [M39014/02-1301](#) [M39014/22-0631](#) [1210J5000102JCT](#)  
[1210J2K00102KXT](#) [1210J5000103KXT](#) [1210J5000223KXT](#) [D55342E07B379BR-TR](#) [D55342E07B523DR-T/R](#) [1812J1K00103KXT](#)  
[1812J1K00473KXT](#) [1812J2K00680JCT](#) [1812J4K00102MXT](#) [1812J5000102JCT](#) [1812J5000103JCT](#) [1812J5000682JCT](#) [NIN-FB391JTRF](#)  
[NIN-FC2R7JTRF](#) [NPIS27H102MTRF](#) [C1206C101J1GAC](#) [C1608C0G1E472JT000N](#) [C2012C0G2A472J](#) [2220J2K00101JCT](#)  
[KHC201E225M76N0T00](#) [LRC-LRF1206LF-01R025FTR1K](#) [1812J1K00222JCT](#) [1812J2K00102KXT](#) [1812J2K00222KXT](#)  
[1812J2K00472KXT](#) [2-1622820-7-CUT-TAPE](#) [2220J3K00102KXT](#) [2225J2500824KXT](#) [CCR07CG103KM](#) [CGA2B2C0G1H010C](#)  
[CGA2B2C0G1H040C](#) [CGA2B2C0G1H050C](#) [CGA2B2C0G1H060D](#) [CGA2B2C0G1H070D](#) [CGA2B2C0G1H151J](#) [CGA2B2C0G1H1R5C](#)  
[CGA2B2C0G1H2R2C](#) [CGA2B2C0G1H3R3C](#) [CGA2B2C0G1H680J](#) [CGA2B2C0G1H6R8D](#) [CGA2B2X8R1H221K](#) [CGA2B2X8R1H472K](#)  
[CGA3E1X7R1C474K](#)