

Connect the embedded world to the internet

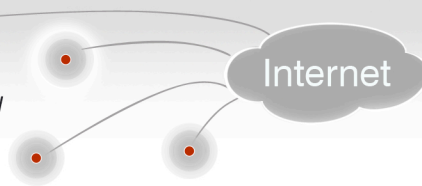

FlyportPRO Wi-Fi 802.11G

System on module

- 802.11g WIFI
 - Infrastructure mode
 - softAP mode
 - Ad hoc mode
- Microchip PIC 24FJ256GB206
16 bit processor
- WiFi Transceiver
Microchip MRF24WG0MA/MB
PCB Antenna or uFL connector
- Connectivity Services
 - Web server (customizable)
 - TCP
 - FTP
 - UDP
 - SNTP
 - SMTP
 - FOTA: Firmware upgrade over Internet
- 16Mbit Flash Memory for web server and FOTA
- EEPROM
- USB OTG
- RTCC
- Remappable pins at runtime
- Digital I/Os, PWM
- 10 Analog Inputs (10 bits ADC and precise voltage reference)
- 4 UARTs, 1 SPI, 2 I2C
- Serial bootloader onboard

Introduction

FLYPORTPRO Wi-Fi is a miniature **web server module** featuring a fully integrated 802.11g Wi-Fi interface and several interfaces to the 'real world'.

The module integrates a powerful **16 bit processor** which runs custom applications and a **Wi-Fi certified transceiver** which handles the connectivity. 2 versions are available: one with PCB antenna and the other with uFL connector for an external antenna.

The module provides the embedded world with a powerful 'Internet engine' to a browser-based interface over Internet, in a small footprint, at low power and low cost. Real time data can be both displayed and/or updated from a standard web browser, even on smartphone or tablets, because FLYPORTPRO supports dynamic web pages.

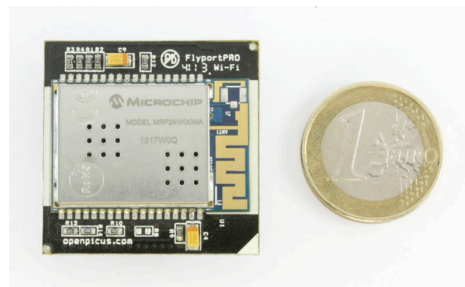

The module form factor is identical to FlyportPRO Ethernet and FlyportPRO GPRS and compatible pinout.

FLYPORT is powered by openPicus framework based on FreeRTOS. The free IDE allows to create applications, to import web pages and to compile and download code to the module.

Features

16 Bit Processor	PIC24FJ256GB206 - 256K Flash – 96K Ram – 16 Mips
Transceiver	MRF24WG0MA/MB 802.11g Wi-Fi certified
Antenna	PCB antenna or uFL connector for external antenna
Power Supply	3,3V
Low power	Hibernation 20mA and Sleep 180uA
USB	On the Go (OTG)
Integrated RTC	32,768 Khz quartz onboard
Digital I/O	up to ..., remappable at Runtime
Analog In	10 channels - 10bits ADC - Voltage ref onboard 2,048V
Communication	up to 4 UARTs, SPI, I2C
Flash	16 Mbit
Eeprom	64 Kbit
Connectors	2*30 ways, pitch 1.27mm female pin header
Dimensions	34 x 34 x 9 mm, 10 grams

Applications

- Webserver based user interfaces to the embedded
- Sensors and automation
- Internet of Things
- Audio over IP
- Building automation and remote control
- Industrial/process management

Connect the embedded world to the internet

Internet

openPICUS

Introduction

FLYPORTPRO Wi-Fi is powered by openPicus framework and mounts a 256K Flash 16bit processor from Microchip that runs the Wireless Stack and the application layer. This means that you have full control of the connectivity (extremely important for energy saving) and the application (for ex. the PIC microcontroller onboard can process data coming from an analog sensor and display these data on the integrated webserver, or send by email or save to a remote FTP server). FLYPORT has an extra 16Mbit Flash memory onboard to store web server pages and for Firmware upgrade over Internet.

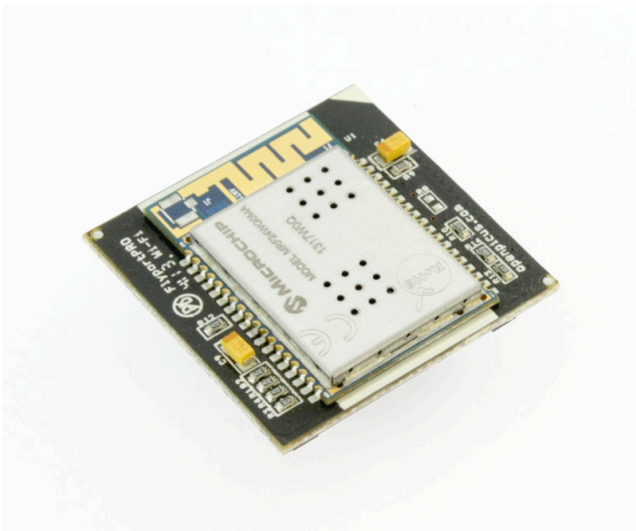

FLYPORT Wi-Fi works in 3 ways:

- Infrastructure mode Flyport connects to a Wi-Fi network (to access points or routers)
- softAP Flyport itself acts like an access point. It's limited to 1 client only
- Ad Hoc Point to point. *Deprecated since not compatible with Android devices!*

Available onboard:

SPI, I2C, UART and embedded Real Time clock.
I/O : analog and digital and PWM.

Remappable pinout:

Special functions such as SPI,UART,PWM and Interrupts can be assigned to any remappable pin at runtime.

Programming:

We provide the free IDEpro with each StarterKit.

C programming skills are needed. No expensive programmer is needed since the serial bootloader loaded on the module allows you to flash the firmware using just a serial cable.

On www.openpicus.com you can find examples, libraries and tools to start to develop immediately.

Connect the embedded world to the internet

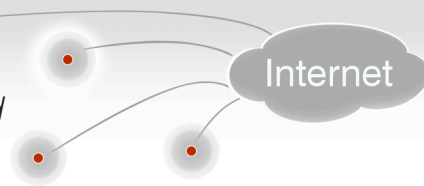

Electrical characteristics

VOLTAGE RATINGS

+3.3V DC Voltage input (pin 4) MIN:+3,0V MAX:+3,3V

CURRENT CONSUMPTION

Power supply 3.3V, Ambient temperature 25°C

Wi-Fi not connected	35 mA	Micro ON and Wi-Fi on but not connected
Wi-Fi connected	150 mA	Micro ON and Wi-Fi infrastructure mode connected to an access point
Hibernate mode	20 mA	Micro ON and Wi-Fi transceiver OFF
Sleep mode	180 uA	Micro OFF and Wi-Fi transceiver OFF

Wi-Fi 802.11g (Microchip transceiver MRF24WG0MA/MB)

Certifications FCC (USA), IC (Canada), ETSI (Europe)

For detailed info about the transceiver and related documentation (FCC ID and more) please visit <http://ww1.microchip.com/downloads/en/DeviceDoc/70686B.pdf>

Security WEP, WPA-PSK, WPA2-PSK Security

Frequency range 2412-2484 Mhz

Output power 16 dBm

**Sensitivity RX min input level, 1Mbit, 8%PER: -95 dBm
RX min input level, 2Mbit, 8%PER: -88 dBm**

**Encryption AES128
RSSI Yes**

Mechanical info

**Dimensions 34*34*9 mm
Weight 10 grams**

Temperature range

Operating range MIN: -20°C MAX: +85°C

Connect the embedded world to the internet

Internet

Block Diagram

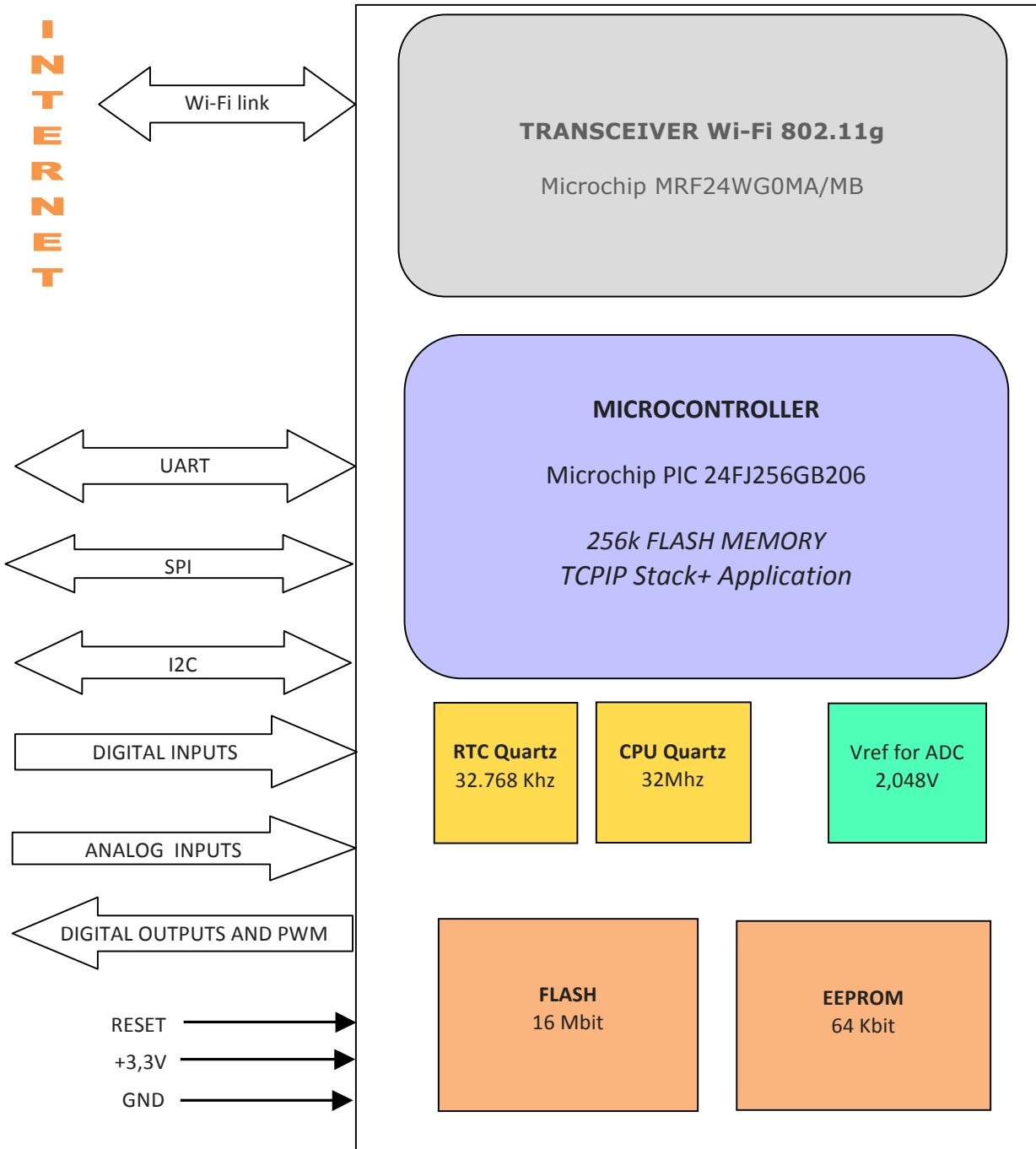

Connect the embedded world to the internet

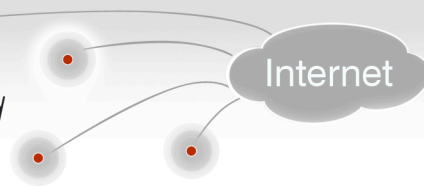

J1 Connector

FLYPORT modules are based on Microchip PIC processor and offer **remappable pins function**. User can customize the hardware configuration by firmware.

Pin	Description	Special Function	5V tolerant	Remap
p1	GPIO	ADC #0	NO	YES
p2	RESET (active low)		NO	NO
p3	GPIO	ADC #1	NO	YES
p4	VDD (+3.3V input)		NO	NO
p5	GPIO	ADC #2	NO	NO
p6	GND		NO	NO
p7	GPIO	ADC #3	NO	YES
p8	GPIO (ICSP – PGD)	ADC #5	NO	YES
p9	GPIO		NO	NO
p10	GPIO (ICSP – PGC)	ADC #4	NO	YES
p11	GPIO		YES	NO
p12	GPIO	ADC #6	NO	YES
p13	GPIO		YES	YES
p14	GPIO		YES	YES
p15	GPIO	Interrupt #0	YES	YES
p16	GPIO	ADC #7	NO	NO
p17	GPIO		YES	YES
p18	GPIO	ADC #8	NO	NO
p19	GPIO	I2C #1 – SDA	YES	YES
p20	GPIO	ADC #9	NO	YES
p21	GPIO	I2C #1 – SCL	YES	YES
p22	UART #1 TX (output) – for programming		NO	YES
p23	UART #1 RX (input) – for programming		YES	YES
p24	I2C #2 – SDA signal (shared with onboard EEPROM)		NO	YES
p25	GPIO	USB D+	NO	NO
p26	I2C #2 – SCL signal (shared with onboard EEPROM)		NO	YES
p27	GPIO	USB D-	NO	NO
p28	GPIO	USBID	YES	YES
p29	USB Vusb		NO	NO
p30	GPIO	USB Vbus	YES	NO

Connect the embedded world to the internet

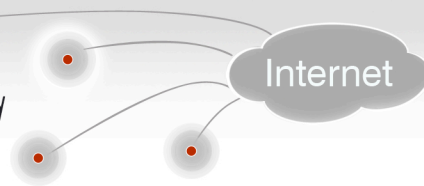

J2 Connector

Pin	Description	Special function	5V tolerant	Remap
p31	GPIO		YES	NO
p32	GPIO		YES	NO
p33	GPIO		YES	NO
p34	GPIO		YES	NO
p35	GPIO		YES	NO
p36	GPIO		YES	NO
p37	GPIO		YES	NO
p38	GPIO		YES	NO
p39	Vref output (2,048V)		NO	NO
p40	Not connected		NO	NO
p41	Not connected		NO	NO
p42	Not connected		NO	NO
p43	Not connected		NO	NO
p44	Not connected		NO	NO
p45	Not connected		NO	NO
p46	Not connected		NO	NO
p47	Not connected		NO	NO
p48	Not connected		NO	NO
p49	Not connected		NO	NO
p50	Not connected		NO	NO
p51	Not connected		NO	NO
p52	Not connected		NO	NO
p53	Not connected		NO	NO
p54	Not connected		NO	NO
p55	Not connected		NO	NO
p56	Not connected		NO	NO
p57	Not connected		NO	NO
p58	Not connected		NO	NO
p59	GND		NO	NO
p60	VDD (+3.3V input)		NO	NO

Connect the embedded world to the internet

Internet

Module overview

TOP VIEW

NO FLY ZONE!

BOTTOM VIEW

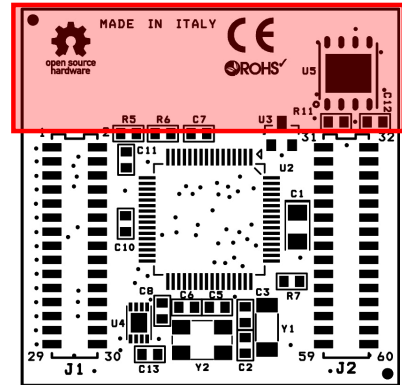
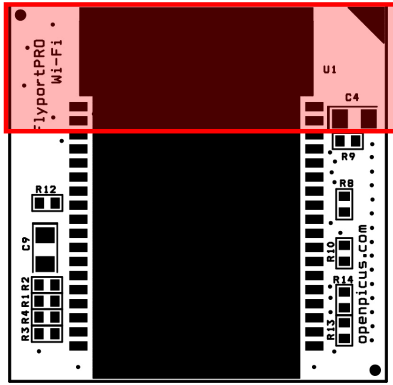

DON'T PLACE COMPONENTS, TRACKS OR COPPER UNDER THE NO FLY ZONE since the Wi-Fi performance may be affected!

Footprint and dimensions

On your carrier board we suggest to use 2*15 ways pitch 1.27mm Male pin header connectors such as:

TH: SAMTEC FTSH-115-04-F-D
SMT: SAMTEC FTSH-115-04-F-DV

NOTE: The following view is made in transparency from TOP. On the right corner there's a triangle sign on the silkscreen to identify where is J1.

TOP VIEW

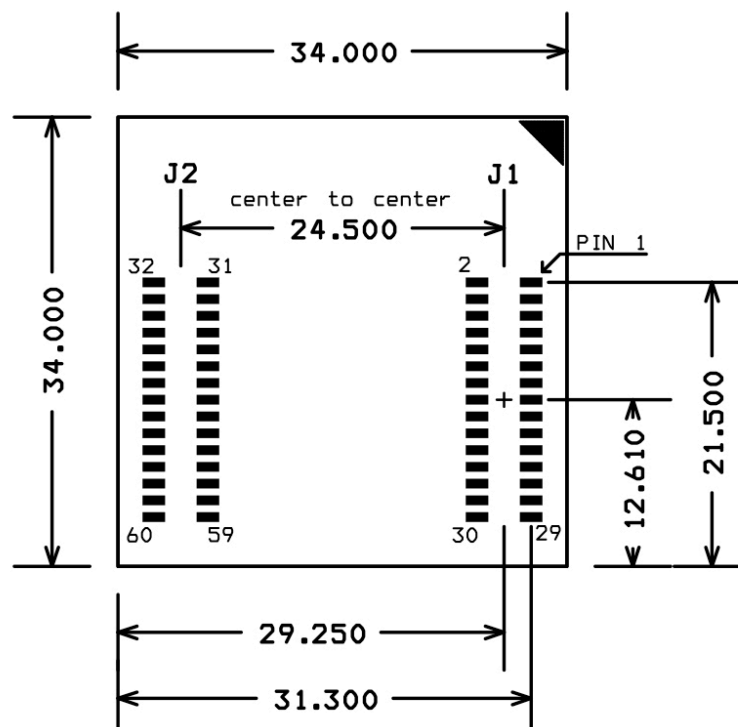

Connect the embedded world to the internet

Internet

open **PICUS**

Ordering information

Buy online from our store or through our resellers and distributors.

Code OP014100 STARTERKIT PRO WIFI
1 Evaluation board and 1 FlyportPRO Wi-Fi

Code OP014001 FLYPORTPRO Wi-Fi 802.11g (PCB Antenna)
Code OP014001 FLYPORTPRO Wi-Fi 802.11g (uFL connector)

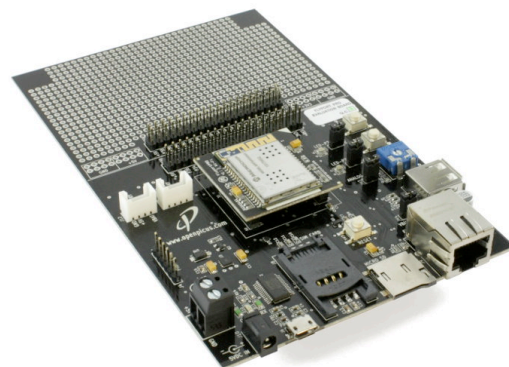

How to start development

Contact us to receive the free IDEpro.

On www.openpicus.com you find a getting started guide, tutorials, libraries and code examples.

Each FLYPORT Module has a serial bootloader onboard.

X-ON Electronics

Largest Supplier of Electrical and Electronic Components

Click to view similar products for [WiFi Modules \(802.11\)](#) category:

Click to view products by [Openpicus](#) manufacturer:

Other Similar products are found below :

[SX-PCEAN2C-SP](#) [BCM43602KMLG](#) [7265.NGWG.W](#) [ENW-49801A1JF](#) [WH-M2SD50NBT](#) [SX-680-2700-SP](#) [RN171-IRM481](#) [FXX-3061-MIX](#) [9668C52W10E](#) [EMIO-1533-00A2](#) [EWM-W162M201E](#) [ISM43340-L77-TR](#) [BCM4352KMLG](#) [BCM43520KMLG](#) [BCM43217KMLG](#) [7265.NGWWB.W](#) [PPC-WL-KIT02-R11](#) [RC-CC2640-A](#) [M113DH3200PS3Q0](#) [SX-PCEAN2c](#) [WT-01S](#) [WT8266-S3](#) [ESP-07S](#) [WT8266-S6](#) [ESP-12S](#) [WT-01F](#) [WT8266-S5](#) [ESP-12F](#) [WT32-S1](#) [ESP-WROOM-02UC](#) [ESP-WROOM-02DC](#) [WT-01N](#) [ESP32-WROOM-32UC](#) [ESP32-WROOM-32DC](#) [ESP-01](#) [ESP-01S](#) [ESP32-WROOM-32\(16MB\)](#) [ESP32-WROVER-E\(8MB\)](#) [ESP32-WROVER-IB\(16MB\)](#) [ESP32-WROVER-E\(16MB\)](#) [ESP32-WROVER-IB\(8MB\)](#) [ESP32-WROOM-32D\(16MB\)](#) [ESP32-WROOM-32U\(8MB\)](#) [ESP32-WROOM-32U\(16MB\)](#) [ESP-WROOM-02\(4MB\)](#) [ESP-WROOM-02D\(4MB\)](#) [ESP32-WROVER-E\(4MB\)](#) [ESP32-WROVER-B\(16MB\)](#) [ESP32-WROVER\(IPEX 4MB\)](#) [EAR00370](#) [EAR00373](#) [EAR00364](#) [ATSAMW25H18-MR210PB1961](#)