



MULTI MICRO SPIDER

EVALUATION KIT (ORG4033-MK04-UAR)

Datasheet

OriginGPS.com



INDEX

1.	SCOPE	4
2.	DISCLAIMER	4
3.	SAFETY INFORMATION	4
4.	ESD SENSITIVITY	4
5.	CONTACT INFORMATION	4
6.	RELATED DOCUMENTATION	4
7.	REVISION HISTORY	5
8.	ABOUT SPIDER FAMILY	5
9.	ABOUT MULTI MICRO SPIDER MODULE	5
10.	ABOUT ORIGINGPS.....	6
11.	DESCRIPTION	6
12.	OUTDOOR OPERATION REMARK.....	6
13.	SCHEMATICS	7
13.1.	MAIN BOARD SCHEMATICS.....	7
13.2.	INTERFACE ADAPTOR SCHEMATICS	8
14.	BILL OF MATERIALS	9
14.1.	MAIN BOARD BILL OF MATERIALS	9
14.2.	INTERFACE ADAPTOR BILL OF MATERIALS	9
15.	ASSEMBLY AND LAYOUT	10
15.1.	MAIN BOARD PCB	10
15.2.	INTERFACE ADAPTOR PCB	12
16.	TTL-232R-3V3 USB-Serial CONVERTER CABLE	15
17.	ORDERING INFORMATION.....	16

TABLE INDEX

TABLE 1 – RELATED DOCUMENTATION.....	4
TABLE 2 – REVISION HISTORY.....	5
TABLE 3 – MAIN BOARD BILL OF MATERIALS.....	9
TABLE 4 – INTERFACE ADAPTOR BILL OF MATERIALS	9
TABLE 5 – USB-SERIAL CONVERTER CABLE HEADER PIN-OUT	15
TABLE 6 – USB-SERIAL CONVERTER CABLE OPERATING PARAMETERS	15
TABLE 7 – ORDERING INFORMATION.....	16
TABLE 8 – ORDERABLE DEVICES.....	16



FIGURE INDEX

FIGURE 1 – MAIN BOARD SCHEMATICS	7
FIGURE 2 – INTERFACE ADAPTOR SCHEMATICS.....	8
FIGURE 3 – MAIN BOARD COMPONENTS PLACEMENT	10
FIGURE 4 – MAIN BOARD SOLDER MASK	10
FIGURE 5 – MAIN BOARD TOP LAYER ROUTING	11
FIGURE 6 – MAIN BOARD BOTTOM LAYER ROUTING	11
FIGURE 7 – INTERFACE ADAPTOR BOARD COMPONENTS PLACEMENT	12
FIGURE 8 – INTERFACE ADAPTOR BOARD SOLDER MASK.....	12
FIGURE 9 – INTERFACE ADAPTOR BOARD TOP LAYER ROUTING	13
FIGURE 10 – INTERFACE ADAPTOR INNER LAYER 2 ROUTING	13
FIGURE 11 – INTERFACE ADAPTOR INNER LAYER 3 ROUTING	14
FIGURE 12 – INTERFACE ADAPTOR BOTTOM LAYER ROUTING.....	14
FIGURE 13 – PIN HEADER SOCKET BOTTOM VIEW	15



1. SCOPE

This document describes the features and specifications of Multi Micro Spider ORG4033 evaluation kit.

2. DISCLAIMER

All trademarks are properties of their respective owners.

Performance characteristics listed in this document do not constitute a warranty or guarantee of product performance. OriginGPS assumes no liability or responsibility for any claims or damages arising out of the use of this document, or from the use of integrated circuits based on this document.

OriginGPS assumes no liability or responsibility for unintentional inaccuracies or omissions in this document.

OriginGPS reserves the right to make changes in its products, specifications and other information at any time without notice.

OriginGPS reserves the right to conduct, from time to time, and at its sole discretion, firmware upgrades.

As long as those FW improvements have no material change on end customers, PCN may not be issued.

OriginGPS navigation products are not recommended to use in life saving or life sustaining applications.

3. SAFETY INFORMATION

Improper handling and use can cause permanent damage to the product.

4. ESD SENSITIVITY

This product is ESD sensitive device and must be handled with care.



5. CONTACT INFORMATION

Support - support@origingps.com or [Online Form](#)

Marketing and sales - marketing@origingps.com

Web – www.origingps.com

6. RELATED DOCUMENTATION

No	DOCUMENT NAME
1	Multi Micro Spider – ORG4033-MK-04 Datasheet
2	MTK NMEA Packet User Manual
3	Feature List and Command Usage- ORG4033 and ORG1510MK-04

TABLE 1 – RELATED DOCUMENTATION



7. REVISION HISTORY

REVISION	DATE	CHANGE DESCRIPTION	Author
1.0	January 18 th , 2016	First release	Mark K.

TABLE 2 – REVISION HISTORY

8. ABOUT SPIDER FAMILY

OriginGPS GNSS receiver modules have been designed to address markets where size, weight, stand-alone operation, highest level of integration, power consumption and design flexibility - all are very important. OriginGPS' Spider family breaks size barrier, offering the industry's smallest fully-integrated, highly-sensitive GPS / GNSS modules.

Spider family features OriginGPS' proprietary NFZ™ technology for high sensitivity and noise immunity even under marginal signal condition, commonly found in urban canyons, under dense foliage or when the receiver's position in space rapidly changes.

Spider family enables the shortest TTM (Time-To-Market) with minimal design risks.

Just connect an antenna and power supply on a 2-layer PCB.

9. ABOUT MULTI MICRO SPIDER MODULE

Multi Micro Spider is a complete SiP featuring miniature LGA SMT footprint designed to commit unique integration features for high volume cost sensitive applications.

Designed to support compact and traditional applications such as smart watches, wearable devices, asset trackers, Multi Micro Spider ORG4033 module is a miniature multi-channel GPS/ GLONASS/ BEIDOU with SBAS, QZSS and other regional overlay systems receiver that continuously tracks all satellites in view, providing real-time positioning data in industry's standard NMEA format.

Multi Micro Spider ORG4033 module offers superior sensitivity and outstanding performance, achieving rapid TTFF in less than one second, accuracy of approximately two meters, and tracking sensitivity of -165dBm.

Sized only 5.6mm x 5.6mm Multi Micro Spider ORG4033 module is industry's small sized, record breaking solution.

Multi Micro Spider ORG4033 module is introducing industry's lowest energy per fix ratio, unparalleled accuracy and extremely fast fixes even under challenging signal conditions, such as in built-up urban areas, dense foliage or even indoor.

Integrated GPS SoC incorporating high-performance microprocessor and sophisticated firmware keeps positioning payload off the host, allowing integration in embedded solutions with low computing resources.

Innovative architecture can detect changes in context, temperature, and satellite signals to achieve a state of near continuous availability by maintaining and opportunistically updating its internal fine time, frequency, and satellite ephemeris data while consuming mere microwatts of battery power.

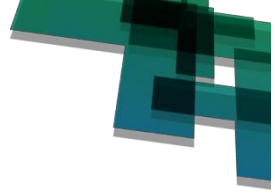

10. ABOUT ORIGINGPS

OriginGPS is a world leading designer, manufacturer and supplier of miniature positioning modules, antenna modules and antenna solutions.

OriginGPS modules introduce unparalleled sensitivity and noise immunity by incorporating Noise Free Zone system (NFZ™) proprietary technology for faster position fix and navigation stability even under challenging satellite signal conditions.

Founded in 2006, OriginGPS is specializing in development of unique technologies that miniaturize RF modules, thereby addressing the market need for smaller wireless solutions.

11. DESCRIPTION

Evaluation Kit of the ORG4033 GNSS Antenna Module comprises the Demo Board, USB to UART cable and DOK with GPS simulator software for PC and documentation.

The Demo Board is built of Main Board, incorporating 3.3V LDO regulator, UART connector, push-button and various test points.

The ORG4033 GNSS Antenna Module is soldered onto the Main Board through the Interface Adaptor.

12. OUTDOOR OPERATION REMARK

ORG4033 module might be affected by outdoor conditions such as wind and temperature changes.

This can be prevented by any enclosure on the module, without blocking the GPS signals (without enclosing the antenna).

Main Board

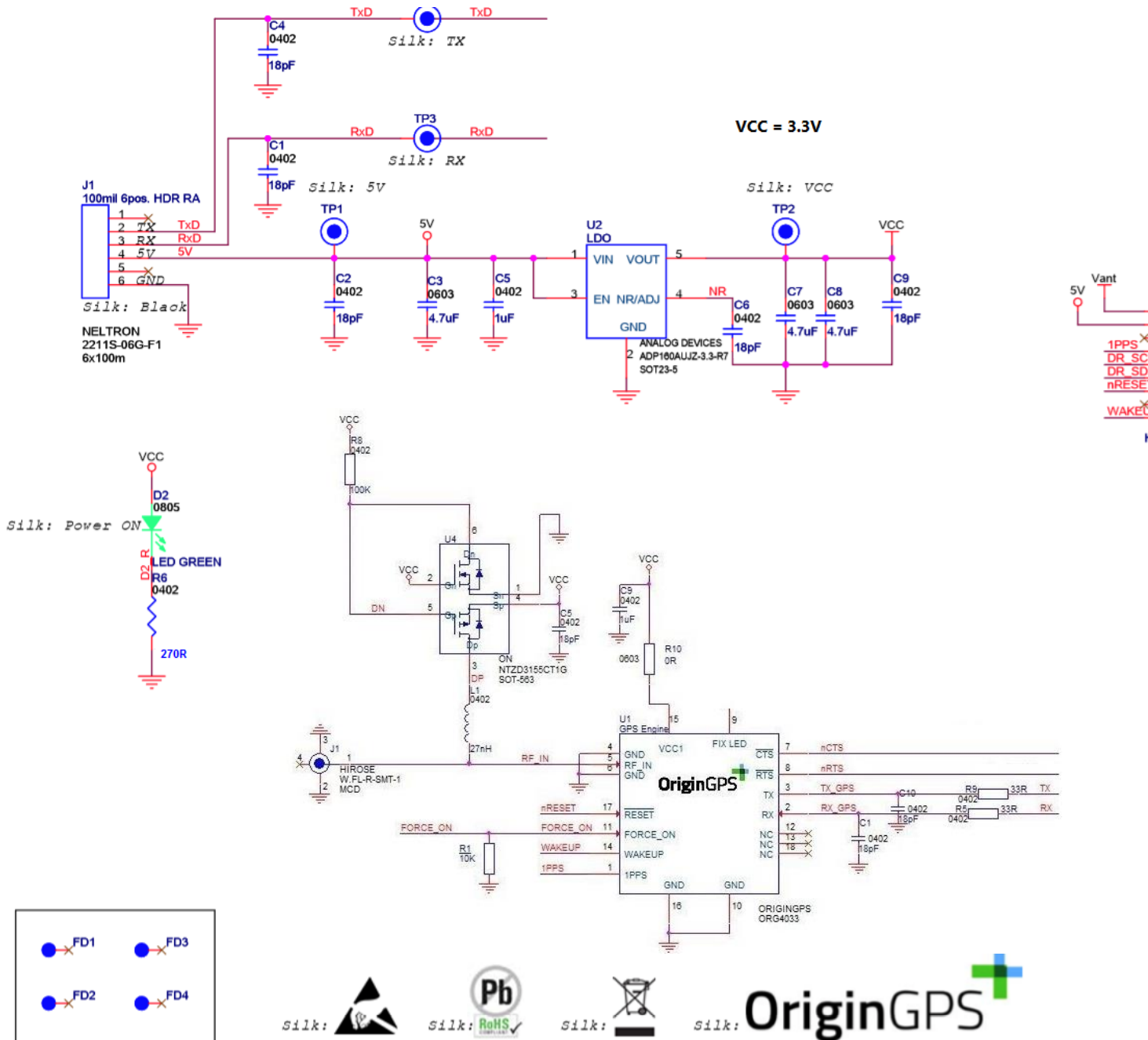

VCC=3V3

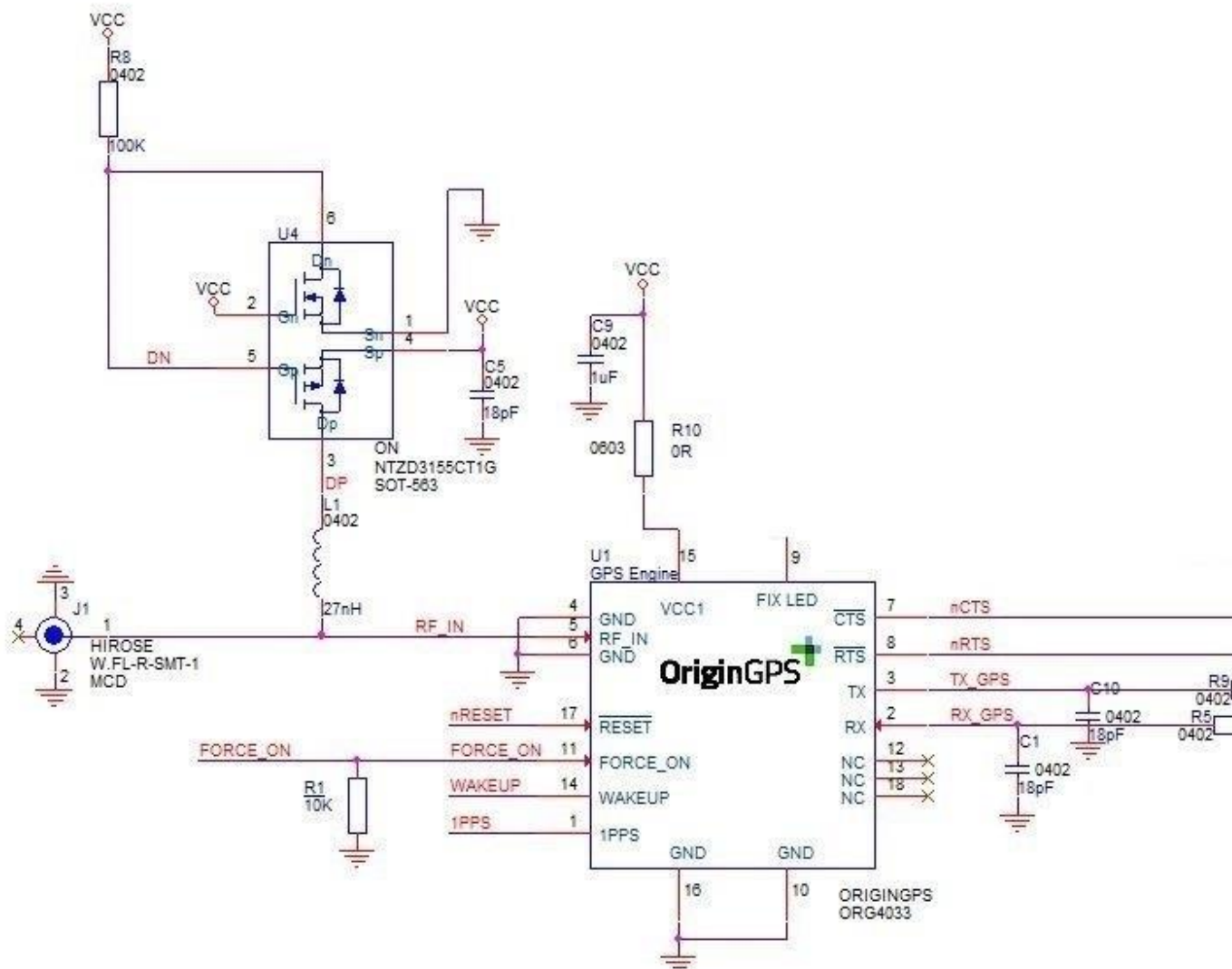



14. BILL OF MATERIALS

14.1 MAIN BOARD BILL OF MATERIALS

Reference	Value	Description	P/N	MFG
C1, C2, C4, C9 C10, C11	18pF	CAP SMT – 18pF ±5% 50V COG	GRM1555C1H180JZ01D	MURATA
C3,C7,C8	4.7µF	CAP SMT 0603 4.7µF ±10% 6.3V X5R	GRM188R60J475KE19D	MURATA
C5	1µF	CAP SMT 0402 1µF ±10% 10V X5R	GRM155R61A105KE15D	MURATA
D2	LED GREEN	LED BLUE SMT 0805 20mA	APT2012SGC	KINGBRIGHT
J3	ZIF CONN	10pos. 0.5mm pitch FPC ZIF SMT Conn.	52746-1071	MOLEX
Q1	BSS138	N-CH 0.2A 50V SOT23 Power MOSFET	BSS138LT1G	ON
R3, R4, R6	33R	RES SMT 0402 33R ±1%	RM04FTN033R	TA-I
R5	270R	RES SMT 0402 270R ±1%	RM04FTN270R	TA-I
J1	HDR	HEADER 6 POS. "0.1 RIGHT ANGLE	2211S-06G-F1	NELTRON
U1	LDO	3.3V 200mA LDO W. Discharge Reg. SOT23	ADP160AUJZ-3.3-R7	AD
J2	Connector	18 pin connector		

TABLE 3 - MAIN BOARD BILL OF MATERIALS

14.2 INTERFACE ADAPTOR BILL OF MATERIALS

Reference	Value	Description	P/N	MFG
ANT1		Ultra Small SMD Coaxial Conn.	W.FL	HIROSE
C1, C5, C10	18pF	CAP SMT 0402 18pF 50V ±5% 16V	GRM1555C1H180JZ01D	MURATA
C9	1µF	CAP SMT 0402 1µF ±10% 10V X5R	GRM155R61A105KE15D	MURATA
L1	27nH	IND SMT 27nH 0402	LQG115HS27NJ02	MURATA
R5,R9	33R	RES SMT 0402 33R ±1%	RM04FTN33R0	TA-I
R10	0R	RES SMT 0604 0R	RM04FTN33R0	TA-I
R8	100KΩ	RES SMT 0402 100KΩ ±1%	RM04FTN1003	TA-I
U1	MODULE	GNSS MODULE SMT LGA	ORG4033 –MK-04	ORIGINGPS
U4	NTZD3156C	Compl. N-P-Ch. MOSFET w integr PUR PDR ESD Protection	NTZD3156CT1G	ON

TABLE 4 - INTERFACE ADAPTOR BILL OF MATERIALS



15. ASSEMBLY AND LAYOUT

14.1 MAIN BOARD PCB

Main Board for the ORG4033 GNSS Antenna Module is 2 layers 1.6mm thickness FR4 PCB.

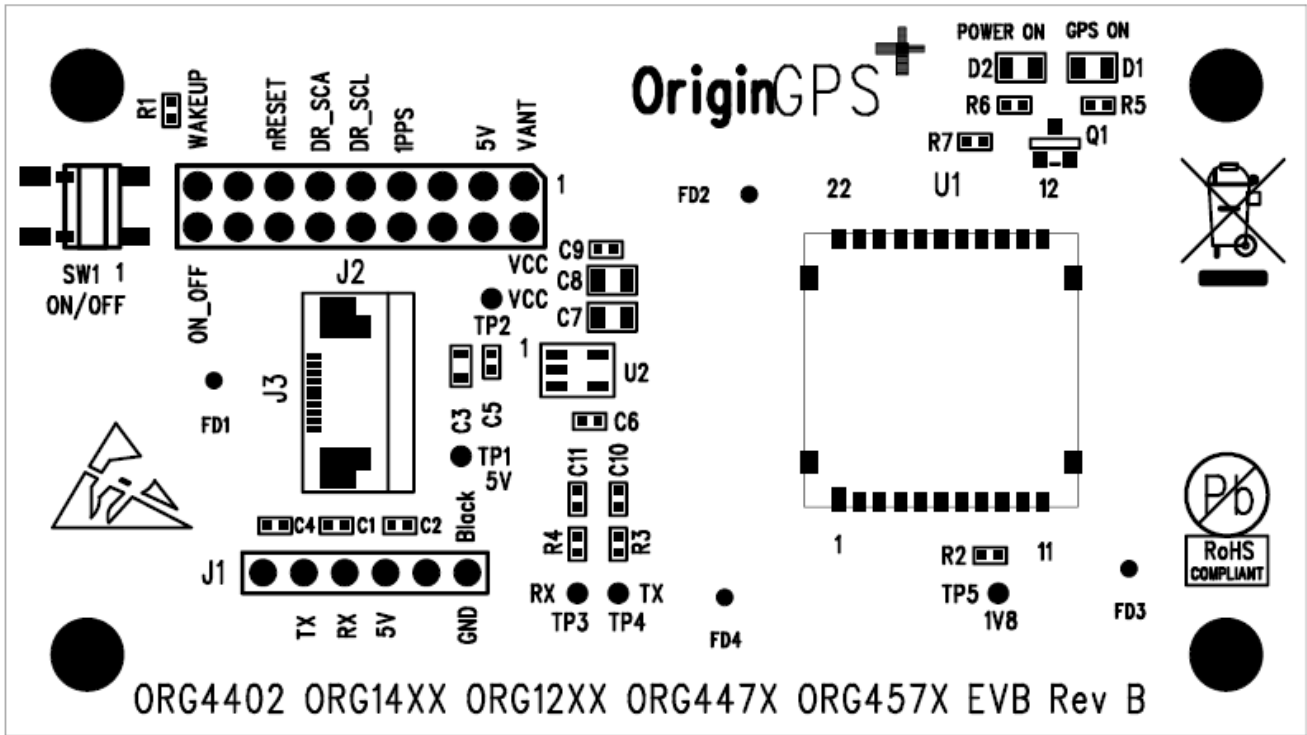

FIGURE 3 - MAIN BOARD COMPONENTS PLACEMENT

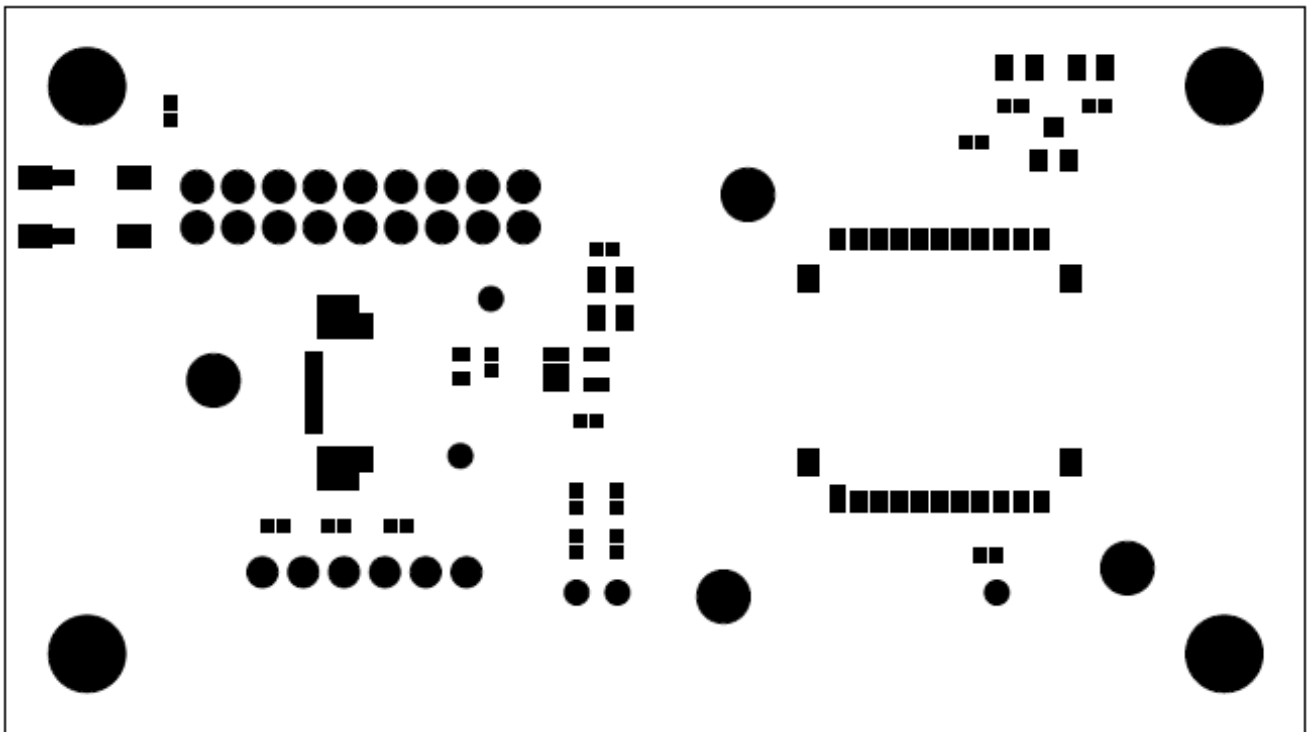

FIGURE 4 - MAIN BOARD SOLDER MASK

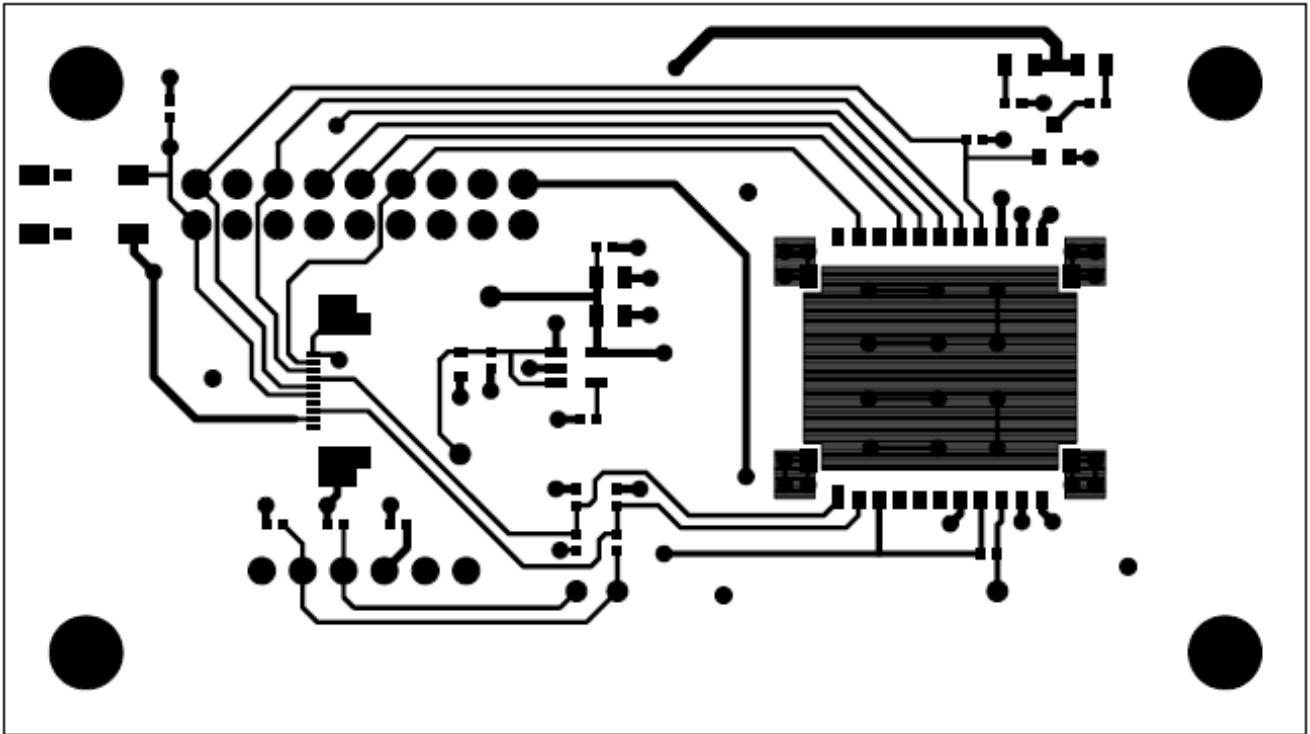

FIGURE 5 – MAIN BOARD TOP LAYER ROUTING

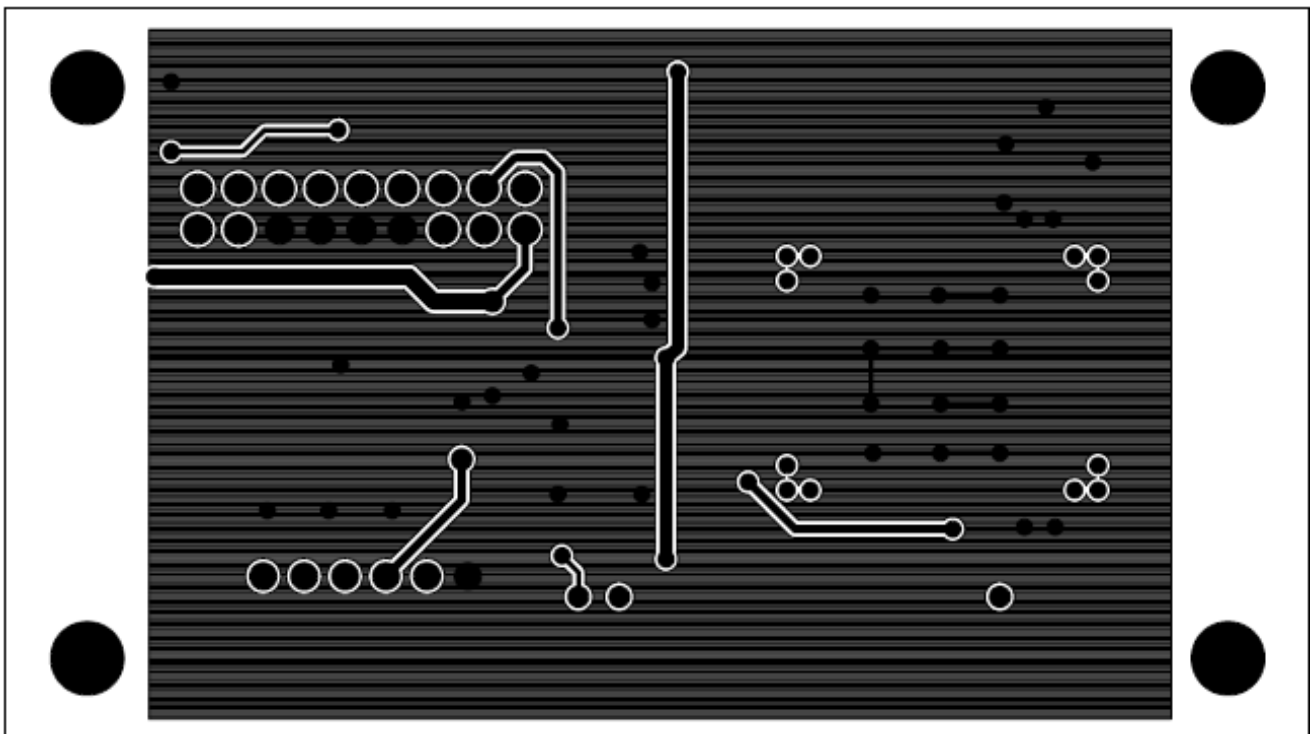

FIGURE 6 – MAIN BOARD BOTTOM LAYER ROUTING



15.2 INTERFACE ADAPTOR PCB

Interface Adaptor Board for the ORG4033 GNSS Module is 17mm x 17mm 22 pads 4 layers 0.6mm thickness FR4 PCB.

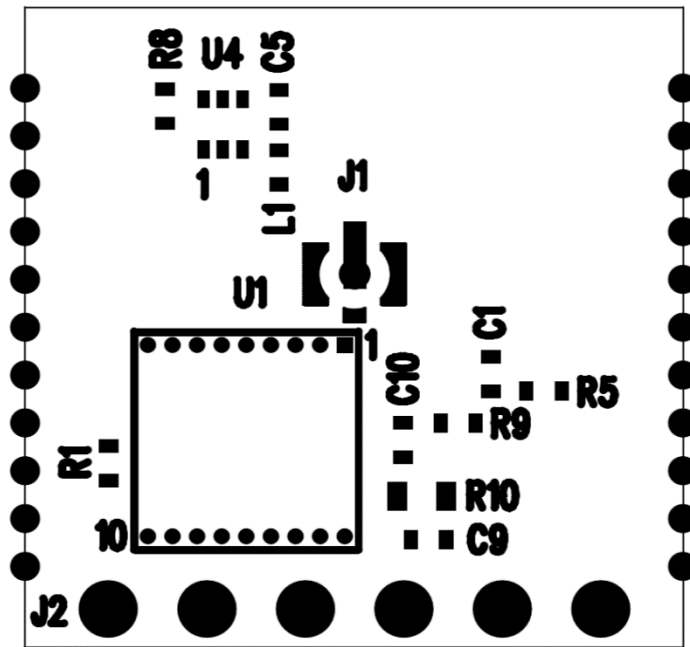

FIGURE 7 - INTERFACE ADAPTOR BOARD COMPONENTS PLACEMENT

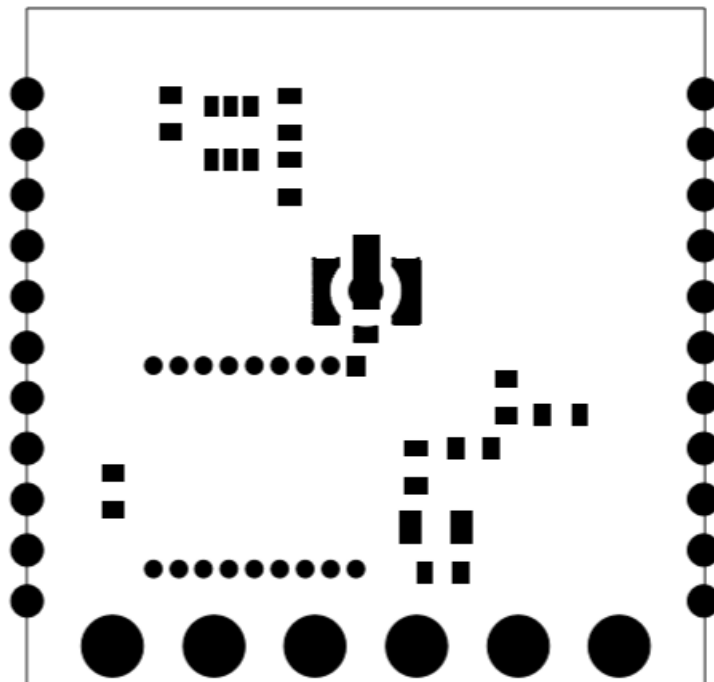

FIGURE 8 - INTERFACE ADAPTOR BOARD SOLDER MASK

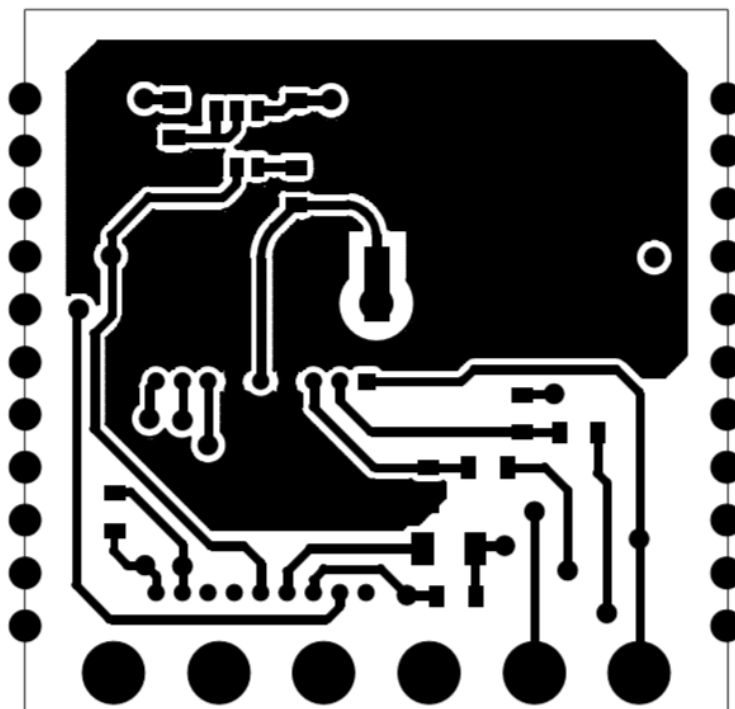

FIGURE 9 - INTERFACE ADAPTOR BOARD TOP LAYER ROUTING

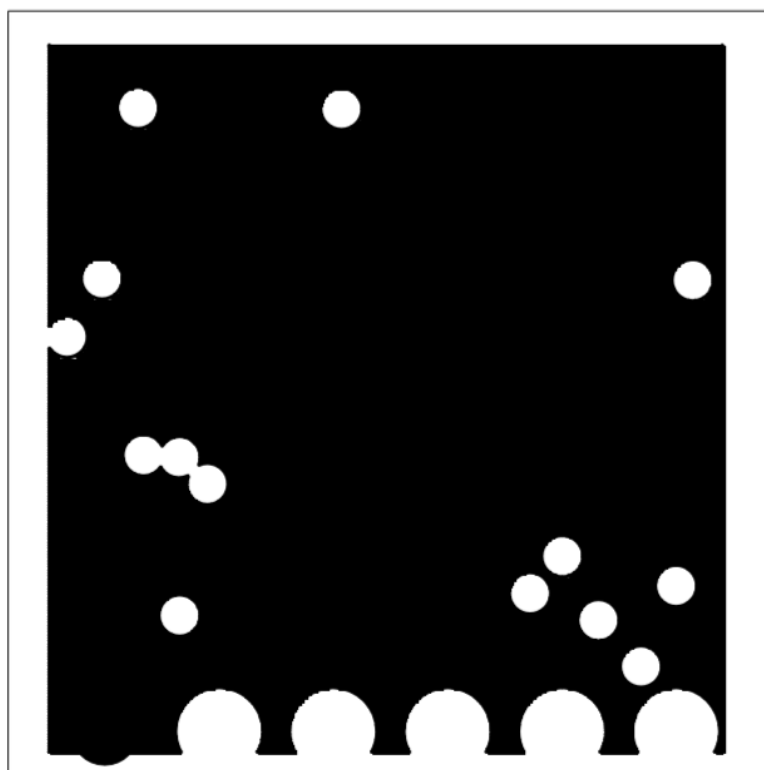

FIGURE 10 - INTERFACE ADAPTOR INNER LAYER 2 ROUTING

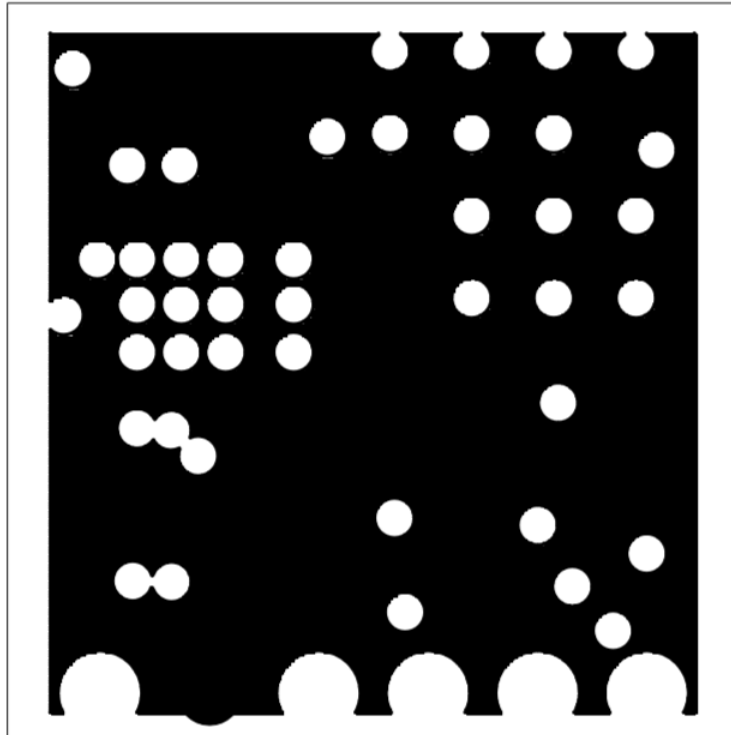

FIGURE 11 - INTERFACE ADAPTOR INNER LAYER 3 ROUTING

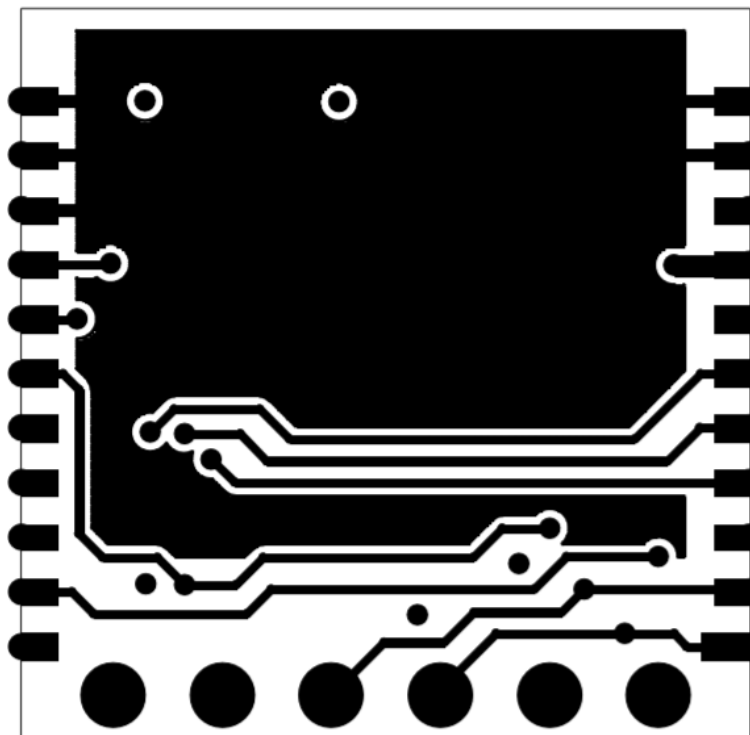

FIGURE 12 - INTERFACE ADAPTOR BOTTOM LAYER ROUTING



16. TTL-232R-3V3 USB-Serial CONVERTER CABLE*

The TTL-232R-3V3 is a USB to Serial converter cable that provides a simple way to connect devices with UART interface to PC.

The TTL-232R-3V3 uses an FTDI FT232RQ IC which is housed inside the USB Type 'A' connector and is terminated at the end of a 1.8 meter cable (6 ft.) with a 2.54mm (".01") pitch header socket which provides an access to UART standard Transmit Data (TxD) and Receive Data (RxD). These lines are operating at 3.3V LVTTTL levels.

Also brought out on the header are +5V and GND.



FIGURE 13 - PIN HEADER SOCKET BOTTOM VIEW

Pin Number	Name	Type	Colour	Description
1	GND	Power	Black	Ground supply pin
2	CTS	Input	Brown	Clear To Send input – not in use
3	VCC	Power	Red	+5V power source, USB specified
4	TXD	Output	Orange	Asynchronous Data output – GPS input
5	RXD	Input	Yellow	Asynchronous Data input – GPS output
6	RTS	Output	Green	Request To Send output – not in use

TABLE 5 - USB-SERIAL CONVERTER CABLE HEADER PIN-OUT

Parameter	Symbol	Test Conditions	Min	Typ	Max	Units
Power Supply Voltage	V_{CC}	Defined by USB V_{BUS}	4.25	5.0	5.25	V
Power Supply Current	I_o		-	-	75	mA
Output Voltage Low State	V_{OL}	$I_{OL} = 8mA$	0.3	0.4	0.6	V
Output Voltage High State	V_{OH}	$I_{OH} = -3mA$	2.2	2.8	3.2	V
Input Voltage State Switching Threshold	V_{IN}	Low \rightarrow High	1.0	1.2	1.5	V
Input Voltage State Switching Hysteresis	V_{HYST}	High \rightarrow Low	20	25	30	mV
Operating Temperature	T_{AMB}		-40	+25	+85	$^{\circ}C$

TABLE 6 - USB-SERIAL CONVERTER CABLE OPERATING PARAMETERS

*Note: For more information refer to FTDI Ltd. TTL-232R TTL To USB Serial Converter Range Of Cables Datasheet, Document Reference No.: FT_000054



17. ORDERING INFORMATION

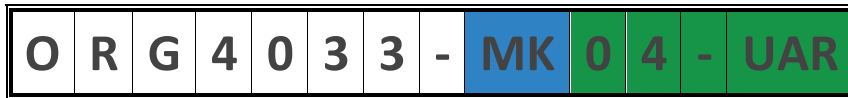

TABLE 7 – ORDERING INFORMATION

PART NUMBER	FW VERSION	HW OPTION	V _{CC} RANGE	PACKAGING	SPQ
ORG4033-MK04-UAR	1	04	5V USB	EVALUATION KIT	1

TABLE 8 – ORDERABLE DEVICES

The default constellation is GPS and GLONASS.

GPS and BEIDOU constellation is also available. For ordering this option contact marketing@origingps.com

X-ON Electronics

Largest Supplier of Electrical and Electronic Components

Click to view similar products for [Interface Development Tools](#) category:

Click to view products by [Origingps](#) manufacturer:

Other Similar products are found below :

[CY4607M](#) [PEX 8748-CA RDK](#) [DP130SSEVM](#) [ISO3086TEVM-436](#) [SP338EER1-0A-EB](#) [ADM00276](#) [ADP5585CP-EVALZ](#) [PEX8724-CA RDK](#) [PEX 8732-CA RDK](#) [PEX8747-CA RDK](#) [AS8650-DB](#) [MLX80104 TESTINTERFACE](#) [I2C-CPEV/NOPB](#) [ISO35TEVM-434](#) [KIT33978EKEVB](#) [416100120-3](#) [XR17D158CV-0A-EVB](#) [XR17V358/SP339-E4-EB](#) [XR17V358/SP339-E8-EB](#) [XR18910ILEVB](#) [XR22804IL56-0A-EB](#) [ZSC31050KIT V3.1](#) [ZSC31150KIT V1.2](#) [SCRUBBER-EVM](#) [SI838XISO-KIT](#) [73931-3022](#) [XIO2200AEVM](#) [XIB-E](#) [XBIB-U-SP](#) [TW-DONGLE-USB](#) [EVAL-ADM2483EBZ](#) [EVAL-ADM2491EEBZ](#) [ATUSB-PCB-80146](#) [EVB-USB83340](#) [MAX9921EVKIT](#) [MAXREFDES23DB#](#) [MAX9291COAXEVKIT#](#) [MAX9286COAXEVKIT#](#) [MAX3535EEVKIT+](#) [MAX3223EEVKIT+](#) [MAX3100EVKIT](#) [MAX13235EEVKIT](#) [MAX14970EVKIT#](#) [MAX14826EVKIT#](#) [3298](#) [XR21B1424IV64-0A-EVB](#) [XR21B1421IL24-0A-EVB](#) [XTIB-U](#) [XR17D152CM-0A-EVB](#) [XR22802IL56-0A-EB](#)