



MICRO SPIDER (ORG4475) GPS RECEIVER MODULE

Evaluation Kit Datasheet

OriginGPS.com



INDEX

1.	SCOPE.....	4
2.	DISCLAIMER	4
3.	SAFETY INFORMATION	4
4.	ESD SENSITIVITY	4
5.	CONTACT INFORMATION	4
6.	RELATED DOCUMENTATION.....	4
7.	REVISION HISTORY	4
8.	GLOSSARY	5
9.	ABOUT SPIDER FAMILY.....	6
10.	ABOUT MICRO SPIDER MODULE	6
11.	ABOUT ORIGINGPS.....	6
12.	DESCRRPTION.....	7
13.	SCHEMATICS	8
13.1.	SCHEMATICS - DB	8
13.2.	SCHEMATICS – AD1	9
14.	BILL OF MATERIALS	10
14.1.	MAIN BOARD BILL OF MATERIALS	10
14.2.	INTERFACE ADAPTOR BILL OF MATERIALS.....	10
15.	ASSEMBLY AND LAYOUT.....	11
15.1.	MAIN BOARD PCB	11
15.2.	INTERFACE ADAPTOR PCB	12
16.	TTL-232R-3V3 USB-SERIAL CONVERTER CABLE*	16
17.	ORG9802 MINIATURE PASSIVE ANTENA ASSEMBLY*	17
17.1.	GENERAL	17
17.2.	MECHANICAL SPECIFICATIONS	17
17.3.	ELECTRICAL SPECIFICATIONS	18
18.	ORG9805 EXTERNAL ACTIVE ANTENA*.....	18
18.1.	DESCRIPTION.....	18
18.2.	FEATURES.....	18
18.3.	BENEFITS.....	18
18.4.	BLOCK DIAGRAM	19
18.5.	ELECTRICAL SPECIFICATIONS	20
18.6.	MECHANICAL SPECIFICATIONS	20
19.	I-PEX MHFIII TO SMA-TYPE COAXIAL CABLE ADAPTOR	21

TABLE INDEX

TABLE 1 – RELATED DOCUMENTATION	4
TABLE 2 – REVISION HISTORY	4
TABLE 3	10
TABLE 4	10
TABLE 5	16
TABLE 6	16
TABLE 7 – ORG9802 MECHANICAL SPECIFICATIONS.....	17
TABLE 8	18
TABLE 9 – ORG9805 ELECTRICAL SPECIFICATIONS.....	20
TABLE 10 – ORG9805 MECHANICAL SPECIFICATIONS.....	20

FIGURE INDEX

FIGURE 1 – MAINBOARD COMPONENTS PLACEMENT.....	11
--	----



FIGURE 2 – MAIN BOARD SOLDER MASK..... 11

FIGURE 3 – TOP LAYER ROUTING 12

FIGURE 4 – BOTTOM LAYER ROUTING..... 12

FIGURE 5 – INTERFACE ADAPTER BOARD COMPONENTS PLACEMENT 13

FIGURE 6 – INTERFACE ADAPTER BOARD SOLDER MASK..... 13

FIGURE 7 – INTERFACE ADAPTER BOARD TOP LEVEL ROUTING..... 14

FIGURE 8 – INTERFACE ADAPTER INNER LAYER 1 ROUTING 14

FIGURE 9 – INTERFACE ADAPTER INNER LAYER 2 ROUTING 15

FIGURE 10 – INTERFACE ADAPTER BOTTOM LAYER ROUTING..... 15

FIGURE 11 – PIN HEADER SOCKET INNER VIEW 16

FIGURE 12 – 16

FIGURE 13 – ORG9802 MECHANICAL OUTLINE 17

FIGURE 14 – ORG9805 BLOCK DIAGRAM..... 19

FIGURE 15 – ORG9805 MECHANICAL OUTLINE 21

FIGURE 16 – IPEX HFIII TO SMA-TYPE ADAPTOR MACHANICAL OUTLINE 21



1. SCOPE

This document describes the features and specifications of Micro Spider ORG4475 GPS Evaluation Kit.

2. DISCLAIMER

All trademarks are properties of their respective owners.

Performance characteristics listed in this document do not constitute a warranty or guarantee of product performance. OriginGPS assumes no liability or responsibility for any claims or damages arising out of the use of this document, or from the use of integrated circuits based on this document.

OriginGPS assumes no liability or responsibility for unintentional inaccuracies or omissions in this document. OriginGPS reserves the right to make changes in its products, specifications and other information at any time without notice.

OriginGPS reserves the right to conduct, from time to time, and at its sole discretion, firmware upgrades. As long as those FW improvements have no material change on end customers, PCN may not be issued. OriginGPS navigation products are not recommended to use in life saving or life sustaining applications.

3. SAFETY INFORMATION

Improper handling and use can cause permanent damage to the product.

4. ESD SENSITIVITY

This product is ESD sensitive device and must be handled with care.



5. CONTACT INFORMATION

Support - info@origingps.com or [Online Form](#)

Marketing and sales - marketing@origingps.com

Web – www.origingps.com

6. RELATED DOCUMENTATION

No	DOCUMENT NAME
1	Micro Spider – ORG4475 Evaluation Kit Datasheet
2	Micro Spider – ORG4475 Product Change Notification
3	Spider and Hornet - Software User Manual for CSR® based receivers
4	Spider and Hornet - NMEA Protocol Reference Manual for CSR® based receivers
5	Spider and Hornet - One Socket Protocol Reference Manual for CSR® based receivers
6	Spider and Hornet - Host Interface Application Note
7	Spider and Hornet - Low Power Modes Application Note
8	Spider and Hornet - Jammer Detector and Remover Application Note
9	Spider and Hornet - Client Generated Extended Ephemeris Application Note
10	Spider and Hornet - Server Generated Extended Ephemeris Application Note
11	Spider and Hornet - Ephemeris Push Application Note

TABLE 1 – RELATED DOCUMENTATION

7. REVISION HISTORY

REVISION	DATE	CHANGE DESCRIPTION
A00	June 1, 2012	First release
2.0	January 14, 2015	Format update

TABLE 2 – REVISION HISTORY



8. GLOSSARY

A-GNSS Assisted GNSS
BPF Band Pass Filter
CE European Community conformity mark
CGEE™ Client Generated Extended Ephemeris
CMOS Complementary Metal-Oxide Semiconductor
COMPASS PRC GNSS (same as **BDS** BeiDou-2 Navigation Satellite System)
EGNOS European Geostationary Navigation Overlay Service
EMC Electro-Magnetic Compatibility
ESD Electro-Static Discharge
EVB Evaluation Board
EVK Evaluation Kit
FCC Federal Communications Commission
GALILEO EU GNSS
GLONASS Global Navigation Satellite System
GNSS Global Navigation Satellite System
GPS Global Positioning System
I²C Inter-Integrated Circuit
IC Integrated Circuit
ISO International Organization for Standardization
LDO Low Dropout regulator
LGA Land Grid Array
LNA Low Noise Amplifier
MSAS Multi-functional Satellite Augmentation System
MSL Moisture Sensitivity Level
NFZ™ Noise-Free Zones System
NMEA National Marine Electronics Association
MEMS MicroElectroMechanical Systems
PCB Printed Circuit Board
PPS Pulse Per Second
QZSS Quasi-Zenith Satellite System
REACH Registration, Evaluation, Authorisation and Restriction of Chemical substances
RF Radio Frequency
RHCP Right-Hand Circular Polarized
RoHS Restriction of Hazardous Substances directive
ROM Read-Only Memory
RTC Real-Time Clock
SAW Surface Acoustic Wave
SBAS Satellite-Based Augmentation Systems
SGEE™ Server Generated Extended Ephemeris
SIP System In Package
SMD Surface Mounted Device
SMT Surface-Mount Technology
SOC System On Chip
SPI Serial Peripheral Interface
TCXO Temperature-Compensated Crystal Oscillator
TTF Time To First Fix
TTL Transistor-Transistor Logic
UART Universal Asynchronous Receiver/Transmitter
WAAS Wide Area Augmentation System



9. ABOUT SPIDER FAMILY

OriginGPS GNSS receiver modules have been designed to address markets where size, weight, stand-alone operation, highest level of integration, power consumption and design flexibility - all are very important.

OriginGPS' Spider family breaks size barrier, offering the industry's smallest fully-integrated, highly-sensitive GPS and GNSS modules.

Spider family features OriginGPS' proprietary NFZ™ technology for high sensitivity and noise immunity even under marginal signal condition, commonly found in urban canyons, under dense foliage or when the receiver's position in space rapidly changes.

Spider family enables the shortest TTM (Time-To-Market) with minimal design risks.

Just connect an antenna and power supply on a 2-layer PCB.

10. ABOUT MICRO SPIDER MODULE

Micro Spider is a complete SiP featuring LGA SMT footprint designed to commit unique integration features for high volume cost sensitive applications.

Designed to support ultra-compact applications such as smart watches, wearable devices, trackers and digital cameras, Micro Spider ORG4475 module is a miniature multi-channel GPS with SBAS, QZSS and other regional overlay systems receiver that continuously tracks all satellites in view, providing real-time positioning data in industry's standard NMEA format.

Micro Spider ORG4475 module offers superior sensitivity and outstanding performance, achieving rapid TTFF in less than one second, accuracy of approximately two meters, and tracking sensitivity of -163dBm.

Sized only 5.6mm x 5.6mm Micro Spider ORG4475 module is industry's small sized, record breaking solution.

ORG4475 module integrates LNA, SAW filter, TCXO, RTC crystal and RF shield with market-leading SiRFstarIV™ GPS SoC.

Micro Spider ORG4475 module is introducing industry's lowest energy per fix ratio, unparalleled accuracy and extremely fast fixes even under challenging signal conditions, such as in built-up urban areas, dense foliage or even indoor.

Integrated GPS SoC incorporating high-performance microprocessor and sophisticated firmware keeps positioning payload off the host, allowing integration in embedded solutions with low computing resources.

Innovative architecture can detect changes in context, temperature, and satellite signals to achieve a state of near continuous availability by maintaining and opportunistically updating its internal fine time, frequency, and satellite ephemeris data while consuming mere microwatts of battery power.

11. ABOUT ORIGINGPS

OriginGPS is a world leading designer, manufacturer and supplier of miniature positioning modules, antenna modules and antenna solutions.

OriginGPS modules introduce unparalleled sensitivity and noise immunity by incorporating Noise Free Zone system (NFZ™) proprietary technology for faster position fix and navigation stability even under challenging satellite signal conditions.

Founded in 2006, OriginGPS is specializing in development of unique technologies that miniaturize RF modules, thereby addressing the market need for smaller wireless solutions.



12. DESCRIPTION

Evaluation Kit of the ORG4475 GPS Module comprises the Demo Board, USB to UART Serial Converter Cable, ORG9802 Miniature Passive Antenna Assembly, I-PEX MHFIII to SMA-type Coaxial Cable Adaptor, ORG9805 External Active Antenna, support CD with GPS simulator software for PC and documentation.

The Demo Board assembly is built of Main Board, incorporating 3.3V LDO voltage regulator, UART connector, push-button tactile switch for Push-To-Fix™ interrupt and various test points.

The ORG4475 GPS Module is soldered onto the Main Board through the Interface Adaptor.

The Interface Adaptor includes a single-bit buffer for voltage level translation of TX line, 1.8V LDO voltage regulator, Load Switch for active antenna T-bias and a voltage supervisor for autonomous power-on pulse generation.



13. SCHEMATICS

13.1. SCHEMATICS - DB



13.2. SCHEMATICS – AD1



14. BILL OF MATERIALS

14.1. MAIN BOARD BILL OF MATERIALS

Reference	Value	Description	P/N	MFG
C2, C8	18pF	CAP SMT 0402 18pF ±5% 50V COG	GRM1555C1H180JZ01D	MURATA
C1, C4, C9, C10, C11, C12, C14, C15	100pF	CAP SMT 0402 100pF ±5% 50V COG	GRM1555C1H101JA01D	MURATA
C6	10nF	CAP SMT 0402 10nF ±10% 25V X7R	GRM155R71E103KA01D	MURATA
C3, C5	1µF	CAP SMT 0603 1µF ±10% 10V X5R	GRM188R60J105KA01J	MURATA
C7, C13	4.7µF	CAP SMT 0805 4.7µF ±10% 16V X5R	GRM21BR61C475KA88L	MURATA
R1	1Ω	RES SMT 0402 1Ω ±1%	RM04FTN0010	TA-I
R3, R4, R5, R6, R7	33Ω	RES SMT 0402 33Ω ±1%	RM04FTN0330	TA-I
R2	100KΩ	RES SMT 0402 100KΩ ±1%	RM04FTN1003	TA-I
J1	HDR	HEADER 6 POS. "0.1 RIGHT ANGLE	2211S-06G-F1	NELTRON
SW1	TSW	TACT SWITCH SMT	KSC222JLFS	C&K
U1	LDO	LDO REG. SMT SOT23-5 3.3V 200mA	TLV70033DDCT	TI

TABLE 3 –

14.2. INTERFACE ADAPTOR BILL OF MATERIALS

Reference	Value	Description	P/N	MFG
C1, C5	18pF	CAP SMT 0402 18pF ±5% 50V COG	GRM1555C1H180JZ01D	MURATA
C4, C6	100nF	CAP SMT 0402 100nF ±10% 16V X7R	GRM155R71C104KA88D	MURATA
C2, C3, C8, C9	1µF	CAP SMT 0402 1µF ±10% 10V X5R	GRM155R61A105KE15D	MURATA
J1	W.FL	CONN. RF SMT W.FL	W.FL-R-SMT-1	HIROSE
L1	27nH	IND SMT 0402 27nH ±5% CER	LQG15HS27NJ02	MURATA
R5	100Ω	RES SMT 0402 100Ω ±1%	RM04FTN1000	TA-I
R2, R6	10KΩ	RES SMT 0402 10KΩ ±1%	RM04FTN1002	TA-I
R7, R8	100KΩ	RES SMT 0402 100KΩ ±1%	RM04FTN1003	TA-I
Q1	2N7002	N-CH MOSFET SOT-23	2N7002KT1G	ON
U1	MODULE	MINIATURE GPS MODULE SMT LGA	ORG4475	ORIGINGPS
U2	NLU1GT126	SINGLE BUFFER 3-STATE	NLU1GT126CMX1TCG	ON
U3	TPS3808	LOW IQ POR SUPERVISOR W. MAN. RST	TPS3808G18DRVR	TI
U4	NTZD3155C	N-CH+P-CH CMPL. MOSFET SOT-563	NTZD3155CT1G	ON
U5	TPS72718	1.8V 200mA Low Iq Low N RF LDO	TPS72718DSER	TI

TABLE 4 –



15. ASSEMBLY AND LAYOUT

15.1. MAIN BOARD PCB

Main Board for the ORG4475 GPS Module is 2-layer 1.6mm thickness FR4 PCB.

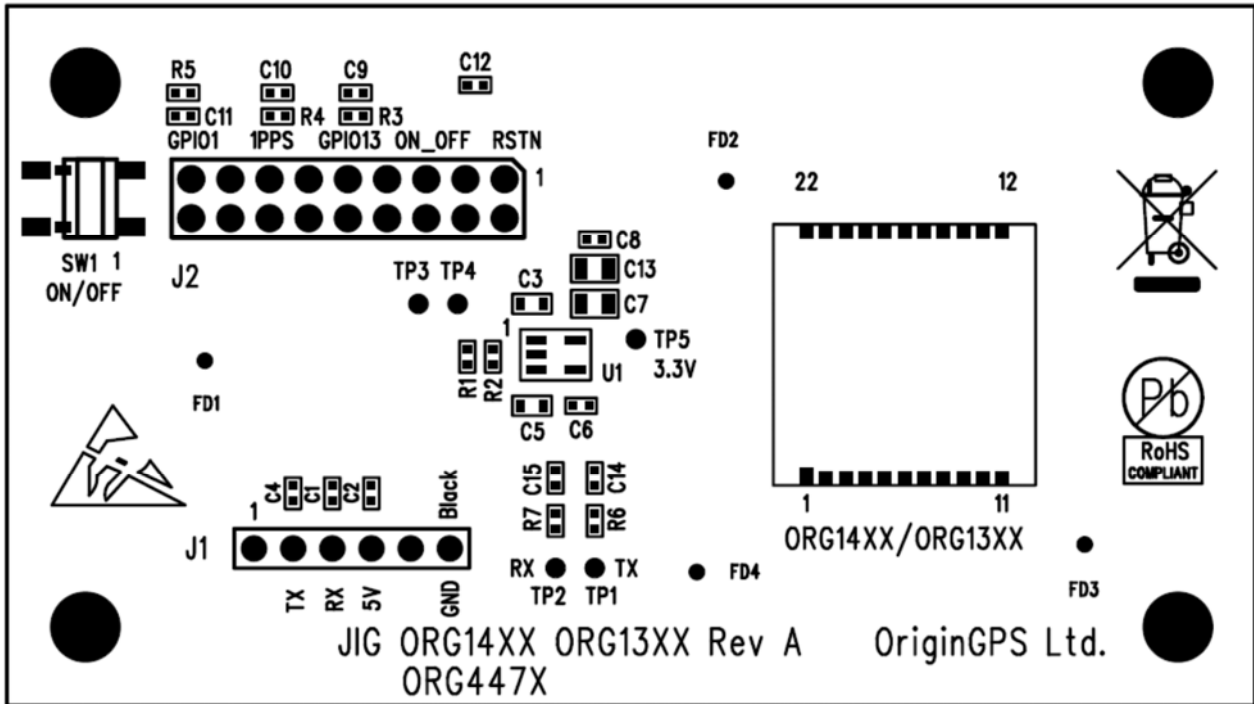

FIGURE 1 – MAINBOARD COMPONENTS PLACEMENT

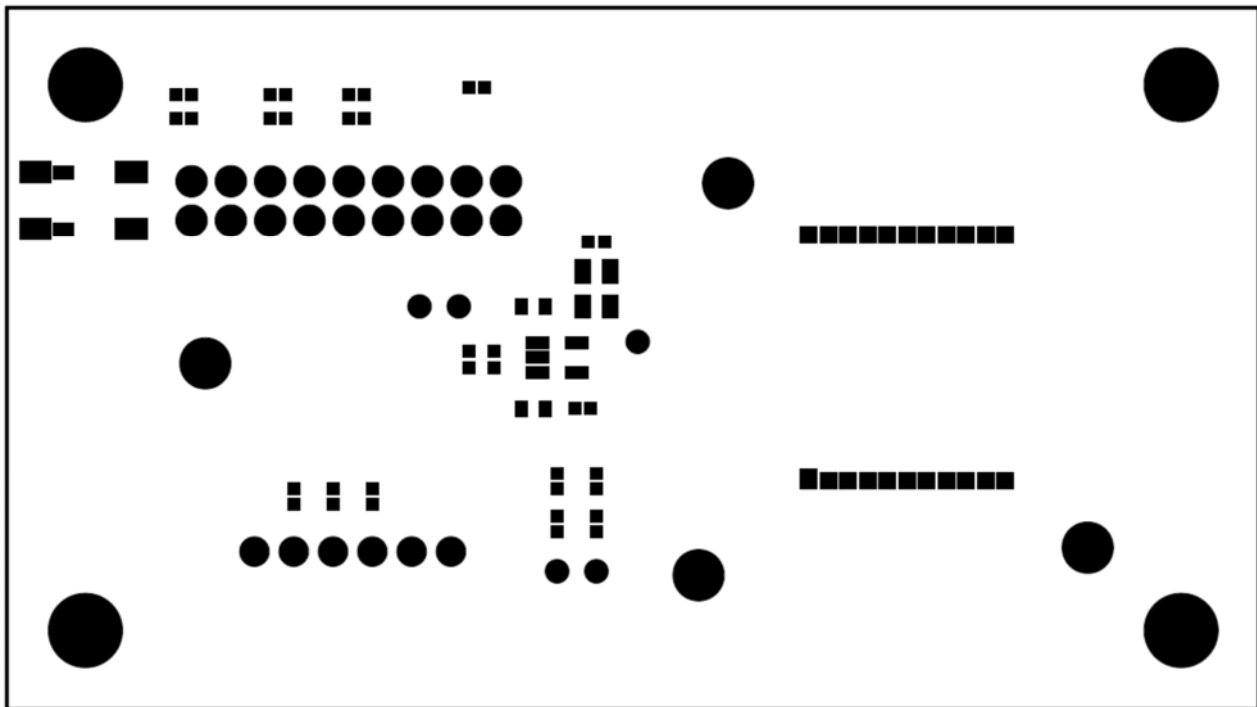

FIGURE 2 – MAIN BOARD SOLDER MASK

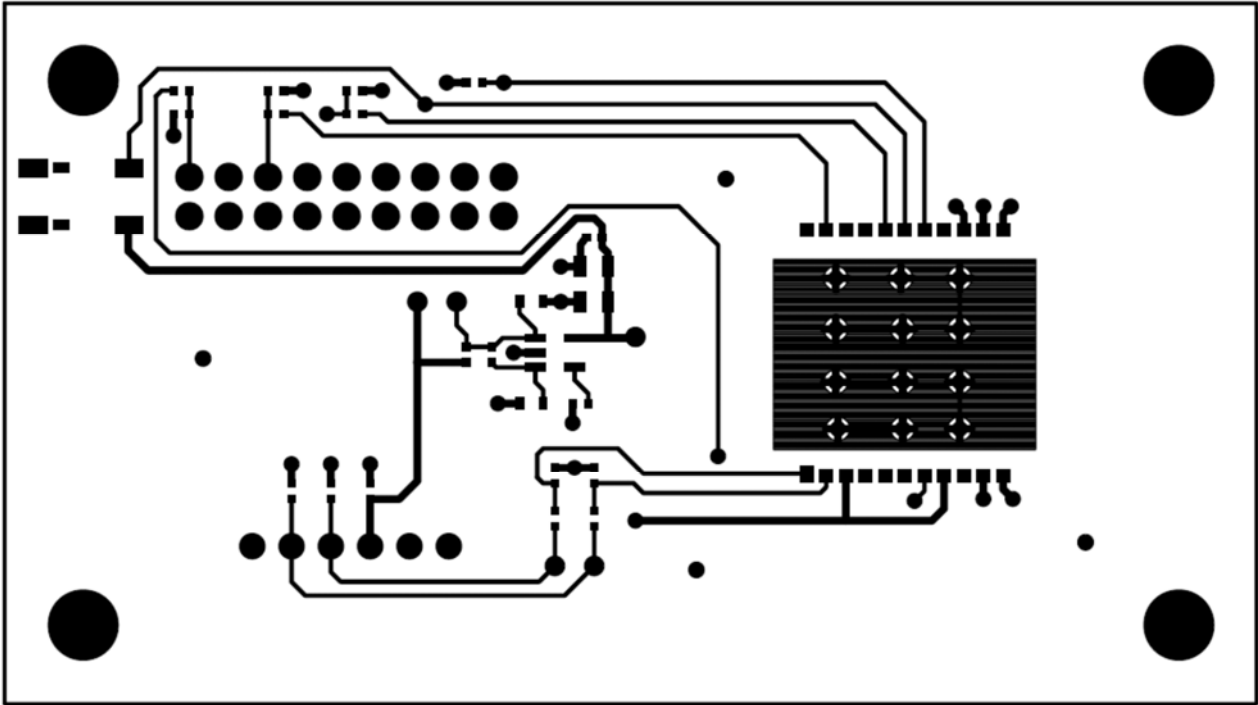

FIGURE 3 – TOP LAYER ROUTING

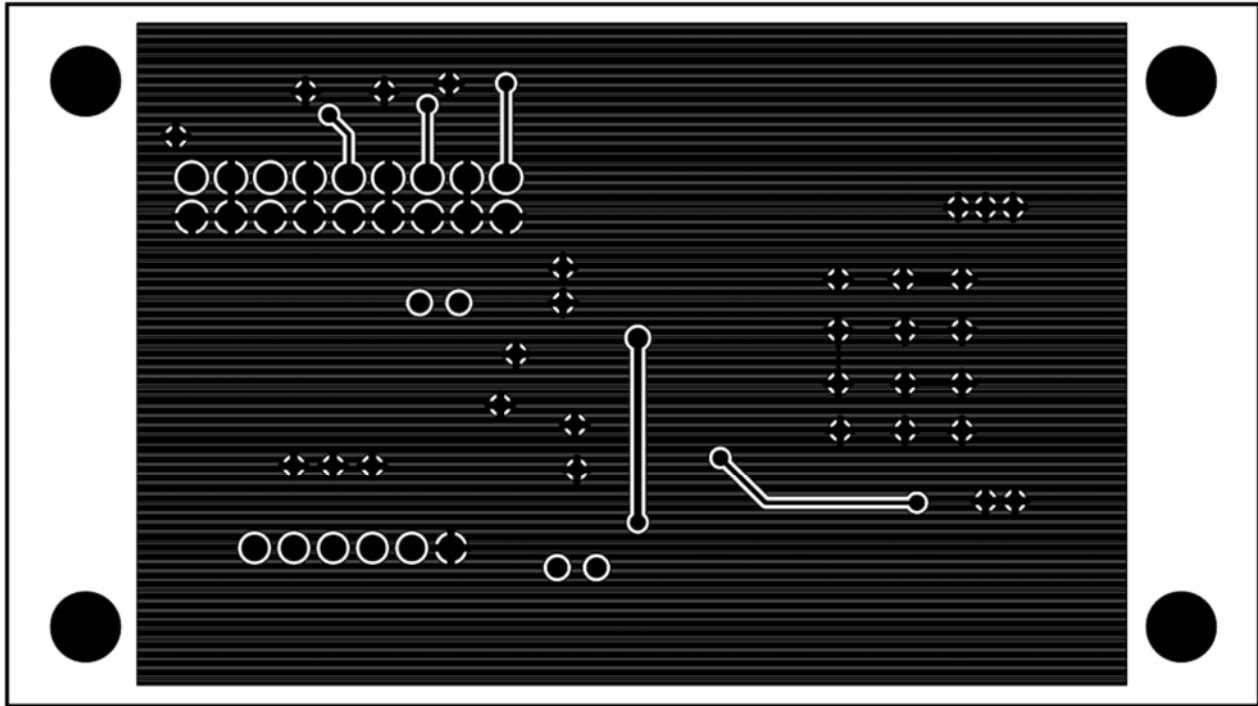

FIGURE 4 – BOTTOM LAYER ROUTING

15.2. INTERFACE ADAPTOR PCB

Interface Adaptor Board for the ORG4475 GPS Module is 17mm x 17mm 22 pads 4 layers 0.6mm thickness FR4 PCB.

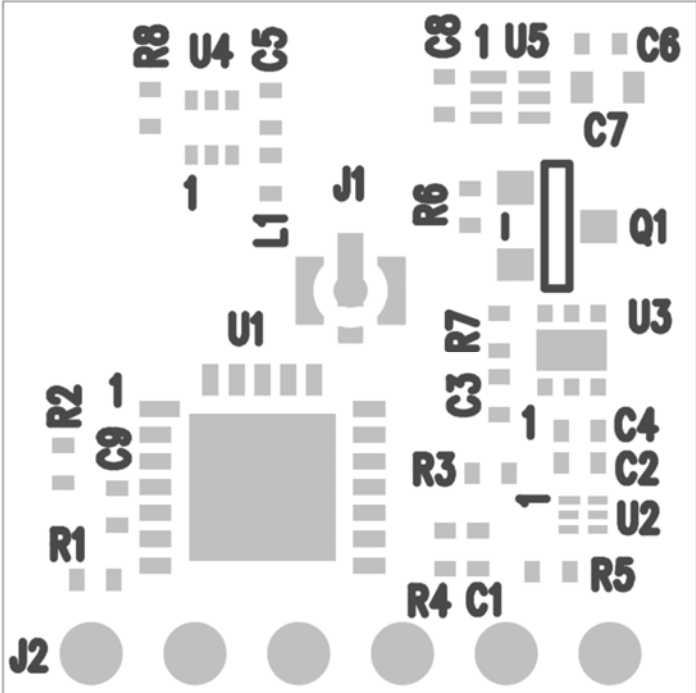

FIGURE 5 – INTERFACE ADAPTER BOARD COMPONENTS PLACEMENT

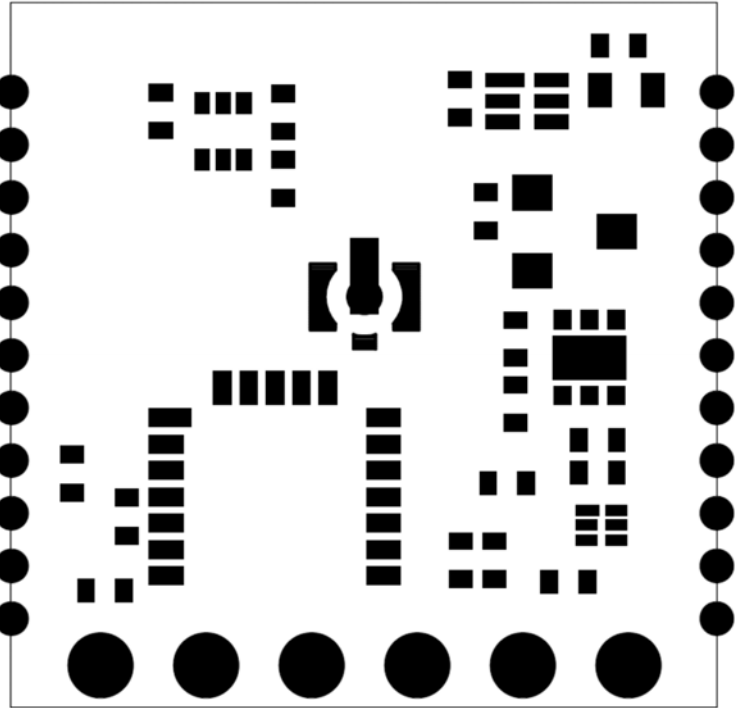

FIGURE 6 – INTERFACE ADAPTER BOARD SOLDER MASK

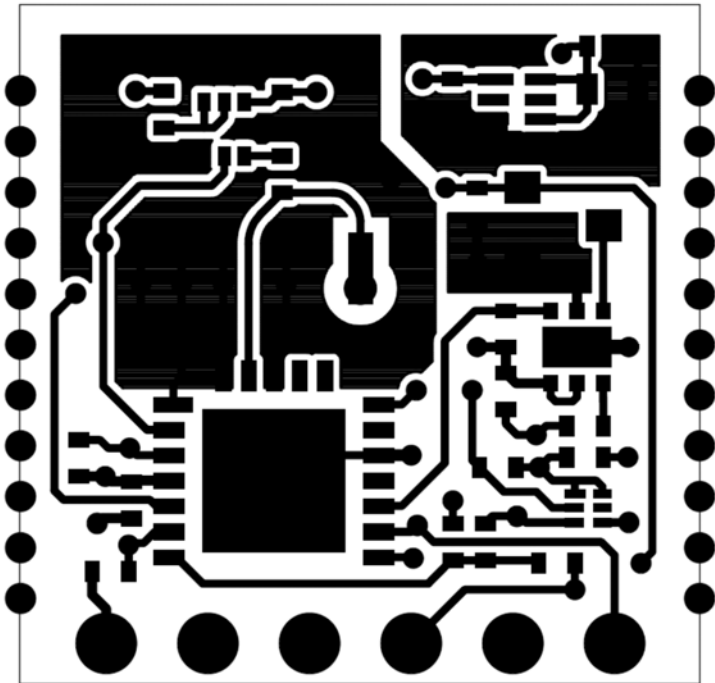

FIGURE 7 – INTERFACE ADAPTER BOARD TOP LEVEL ROUTING

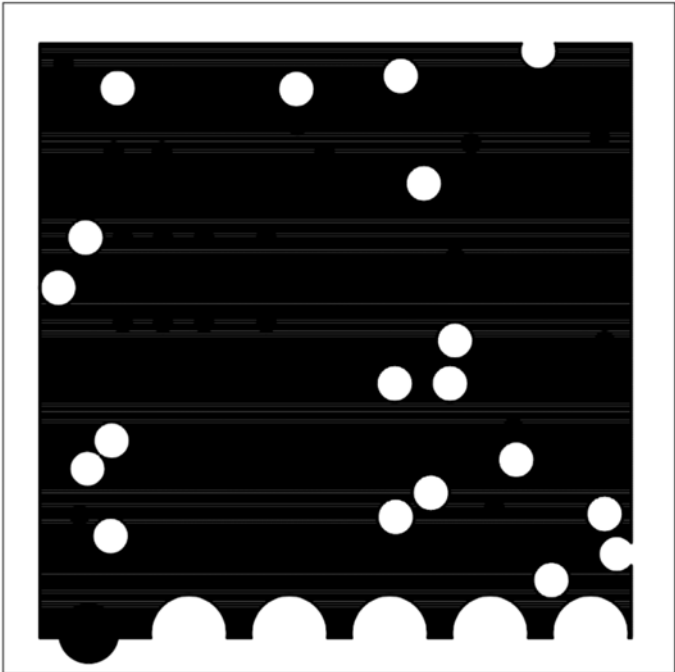

FIGURE 8 – INTERFACE ADAPTER INNER LAYER 1 ROUTING

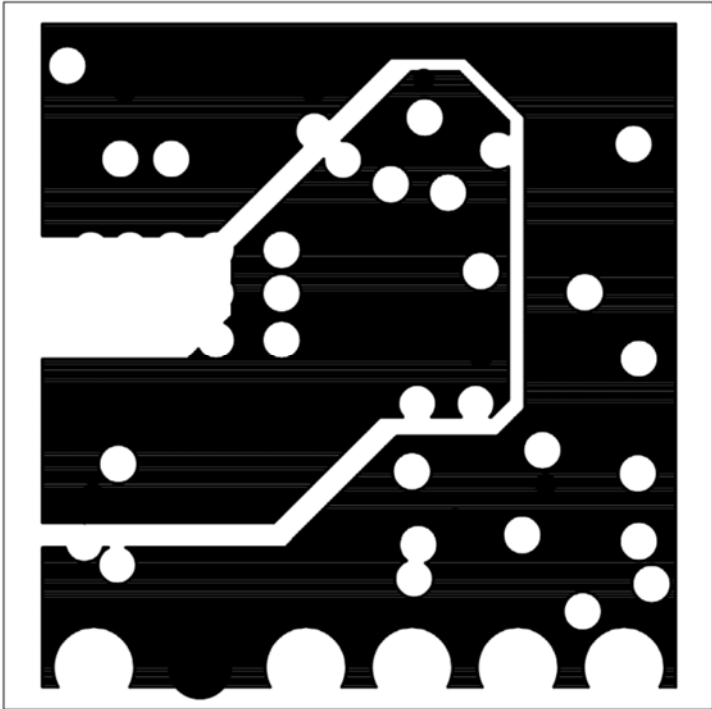

FIGURE 9 – INTERFACE ADAPTER INNER LAYER 2 ROUTING

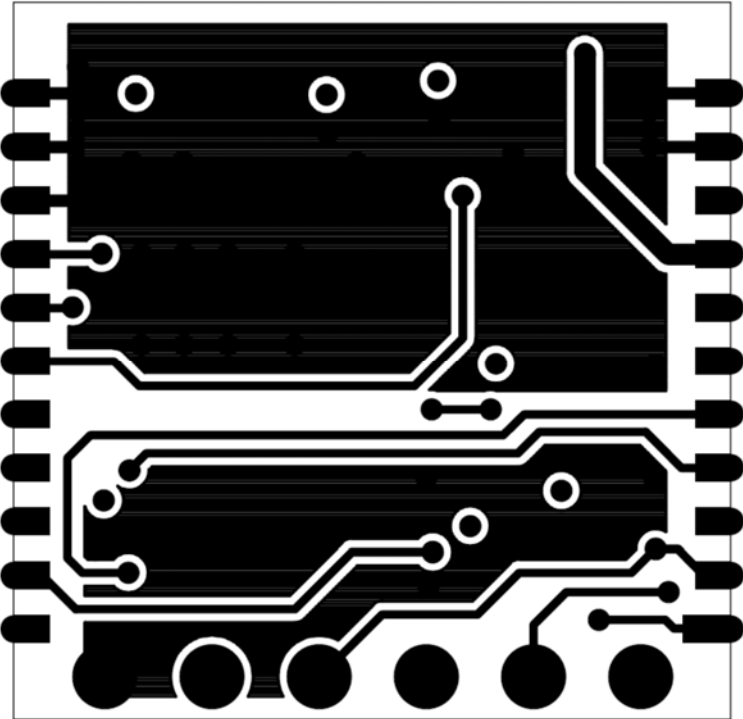

FIGURE 10 – INTERFACE ADAPTER BOTTOM LAYER ROUTING



16. TTL-232R-3V3 USB-SERIAL CONVERTER CABLE*

The TTL-232R-3V3 is a USB to Serial converter cable that provides a simple way to connect devices with UART interface to PC.

The TTL-232R-3V3 uses an FTDI FT232RQ IC which is housed inside the USB Type 'A' connector and is terminated at the end of a 1.8 meter cable (6 ft.) with a 2.54mm ("0.1) pitch header socket which provides an access to UART standard Transmit Data (TxD) and Receive Data (RxD).

These lines are operating at 3.3V LVTTTL levels.

Also brought out on the header are +5V and GND.

Pin Number	Name	Type	Colour	Description
1	GND	Power	Black	Ground supply pin
2	$\overline{\text{CS}}\text{T}$	Input	Brown	Clear To Send input – not in use
3	VCC	Power	Red	+5V power source, USB specified
4	TXD	Output	Orange	Asynchronous Data output – GPS input
5	RXD	Input	Yellow	Asynchronous Data input – GPS output
6	$\overline{\text{RT}}\text{S}$	Output	Green	Request To Send output – not in use

TABLE 5 –

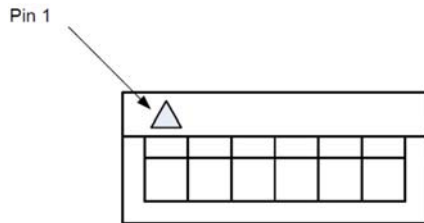

FIGURE 11 – PIN HEADER SOCKET INNER VIEW



FIGURE 12 –

Parameter	Symbol	Test Conditions	Min	Typ	Max	Units
Power Supply Voltage	V_{CC}	Defined by USB V_{BUS}	4.25	5.0	5.25	V
Power Supply Current	I_{O}		-	-	75	mA
Output Voltage Low State	V_{OL}	$I_{\text{OL}} = 8\text{mA}$	0.3	0.4	0.6	V
Output Voltage High State	V_{OH}	$I_{\text{OH}} = -3\text{mA}$	2.2	2.8	3.2	V
Input Voltage State Switching Threshold	V_{IN}	Low \rightarrow High	1.0	1.2	1.5	V
Input Voltage State Switching Hysteresis	V_{HYST}	High \rightarrow Low	20	25	30	mV
Operating Temperature	T_{AMB}		-40	+25	+85	$^{\circ}\text{C}$

TABLE 6 –



*Note: For more information refer to FTDI Ltd. TTL-232R TTL To USB Serial Converter Range Of Cables Datasheet, Document Reference No.: FT_000054

17. ORG9802 MINIATURE PASSIVE ANTENNA ASSEMBLY*

17.1. GENERAL

ORG9802 is a miniature antenna assembly, comprising four components:

- + Ceramic patch antenna element
- + Adaptor PCB
- + Coaxial cable
- + Connector

17.2. MECHANICAL SPECIFICATIONS

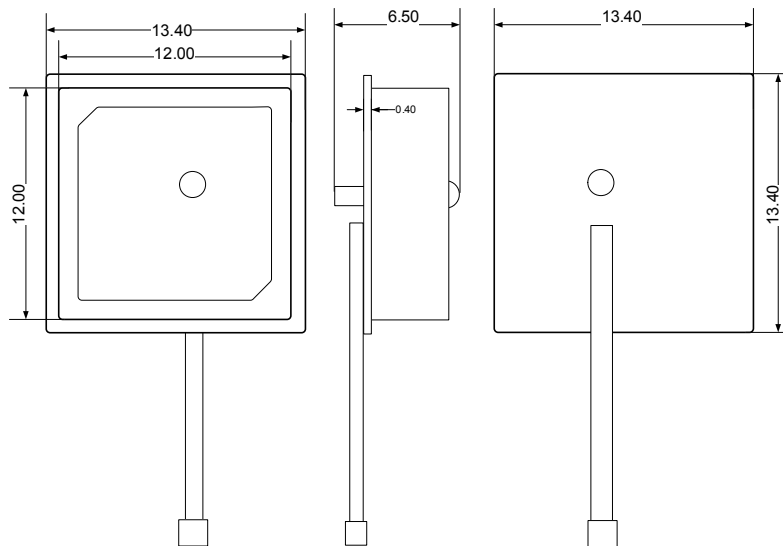

FIGURE 13 – ORG9802 MECHANICAL OUTLINE

Dimensions	Length	Width	Thickness	Weight	
				gr	oz
mm	13.4 ± 0.2	13.4 ± 0.2	6.5 ± 0.1	4.0	
inch	0.528 ± 0.008	0.528 ± 0.008	0.256 ± 0.004	0.14	

TABLE 7 – ORG9802 MECHANICAL SPECIFICATIONS

*Note: For more information refer to OriginGPS ORG9802 Patch Antenna Assembly Datasheet, Document number 300311



17.3. ELECTRICAL SPECIFICATIONS

Parameter	Value	Unit	Notes	
Center frequency (fC)	1575 ± 3	MHz		
Return Loss (S11)	-15 (min)	dB	@fC	
Bandwidth (BW)	7 (min)	MHz	@ f(S11=-9dB)	
VSWR	1.2 (max)			
Impedance (ZA)	50	Ω		
Axial Ratio (AR)	2.5 (max)	dB	Properties of antenna element	
Gain @ fC	900 Elevation	-1.0 (typ)		dBic
	100 Elevation	-6.5 (typ)		dBic
Polarization	R.H.C.P			
Insertion Loss (S21)	3	dB/m	Property of coaxial cable	
Operating Temperature	-40 to +85	°C		

TABLE 8 –

18. ORG9805 EXTERNAL ACTIVE ANTENNA*

18.1. DESCRIPTION

The ORG9805 External Active Antenna incorporates high-efficiency ceramic patch antenna element, high out-of-band rejection band-pass Surface Acoustic Wave (SAW) filter, low Noise Figure and high gain Low Noise Amplifier (LNA), enclosed in plastic case, with coaxial cable terminated by standard SMA-type plug.

The ORG9805 Active Antenna with highest GPS-band performance and notch filtering for out-of band signals provides exceptional sensitivity, high selectivity and noise immunity.

The ORG9805 Active Antenna is built of highest quality materials and components.

The ORG9805 Active Antenna is the perfect match to the OriginGPS GPS receiver modules.

18.2. FEATURES

- + Antenna element with high efficiency for excellent coverage of GPS satellites
- + SAW filter for rejection of out-of-band signals
- + LNA with low Noise Figure and high gain for high sensitivity
- + Plastic case with magnetic base
- + RG-174 flexible coaxial cable of 5m length
- + SMA-type gold plated plug

18.3. BENEFITS

- + High performance
- + Compact size
- + Easy integration



18.4. BLOCK DIAGRAM

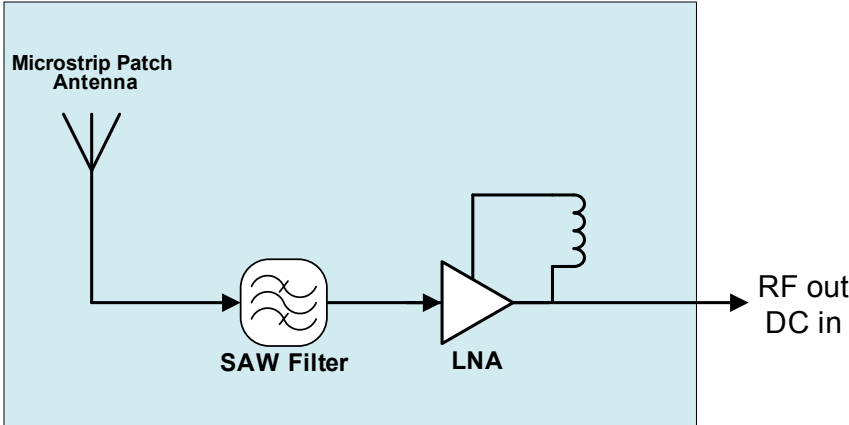

FIGURE 14 – ORG9805 BLOCK DIAGRAM

*Note: For more information refer to OriginGPS ORG9805 External Active Antenna Datasheet, Document number 160112



18.5. ELECTRICAL SPECIFICATIONS

Parameter	Value	Unit	Notes
Center Frequency (fC)	1575 ± 3	MHz	
Bandwidth (BW)	10 (min)	MHz	
Peak Gain	4 (min)	dBic	@ fC, 70mm x 70mm GP
Gain Coverage	-4 (min)	dBic	@ fC, -90° < θ < 90° (over 75% volume)
Axial Ratio (AR)	2.0 (max)	dB	
Polarization	R.H.C.P		
Filter Attenuation	7 (min) 20 (min) 25 (min) 40 (min)	dB	@fC + 20MHz, @fC - 20MHz @fC + 50MHz, @fC - 50MHz @fC + 100MHz @fC - 100MHz
Power Handling	30	dBm	out of band signal
LNA Gain	27 (typ)	dB	without cable loss
LNA Noise Figure	1.5 (max)	dB	
DC Voltage	3 - 5	V	supplied via coaxial cable
DC Current	8.5 (typ)	mA	@3.3V
Cable Insertion Loss	1.2 (typ)	dB/m	
VSWR	2.0 (max)		@output
Impedance	50 ± 1	Ω	@output

TABLE 9 – ORG9805 ELECTRICAL SPECIFICATIONS

18.6. MECHANICAL SPECIFICATIONS

Parameter	Value	Unit	Notes
Size (L x W x T)	48.6 x 39.2 x 15.2	mm	tolerance: ± 0.5mm
Weight	106 (approx.)	g	including cable
Housing	PC		
Color	Black		
Mounting	Magnetic base		
Orientation	Horizontal surface		
Cable Type	RG-174		diameter: 2.7 ± 0.1mm
Cable Length	5	m	
Connector Type	SMA Plug		Gold plated

TABLE 10 – ORG9805 MECHANICAL SPECIFICATIONS

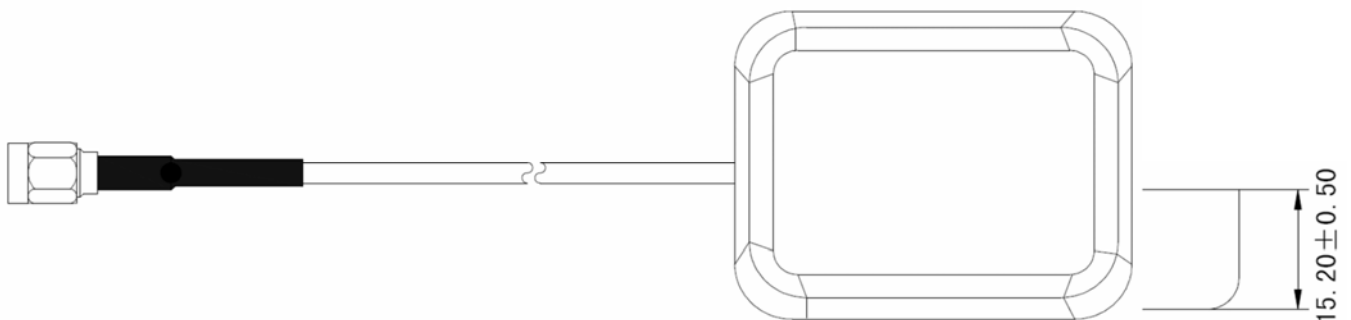

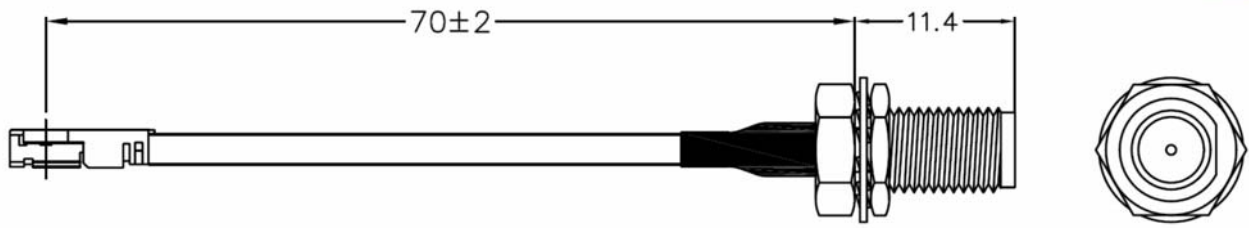

FIGURE 15 – ORG9805 MECHANICAL OUTLINE

19. I-PEX MHFIII TO SMA-TYPE COAXIAL CABLE ADAPTOR

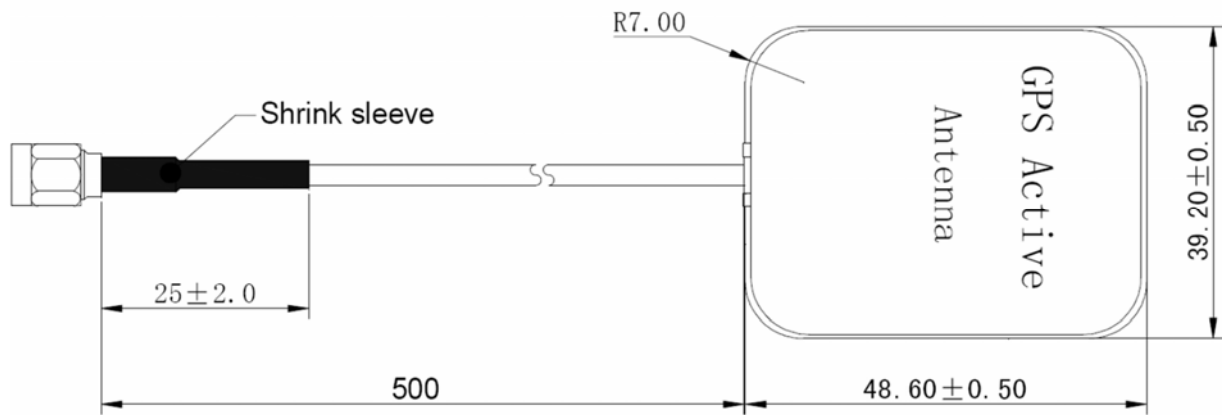

FIGURE 16 – IPEX HFIII TO SMA-TYPE ADAPTOR MACHANICAL OUTLINE

X-ON Electronics

Largest Supplier of Electrical and Electronic Components

Click to view similar products for [Interface Development Tools](#) category:

Click to view products by [Origingps](#) manufacturer:

Other Similar products are found below :

[CY4607M](#) [PEX 8748-CA RDK](#) [DP130SSEVM](#) [ISO3086TEVM-436](#) [SP338EER1-0A-EB](#) [ADM00276](#) [ADP5585CP-EVALZ](#) [PEX8724-CA RDK](#) [PEX 8732-CA RDK](#) [PEX8747-CA RDK](#) [AS8650-DB](#) [MLX80104 TESTINTERFACE](#) [I2C-CPEV/NOPB](#) [ISO35TEVM-434](#) [KIT33978EKEVB](#) [416100120-3](#) [XR17D158CV-0A-EVB](#) [XR17V358/SP339-E4-EB](#) [XR17V358/SP339-E8-EB](#) [XR18910ILEVB](#) [XR22804IL56-0A-EB](#) [ZSC31050KIT V3.1](#) [ZSC31150KIT V1.2](#) [SCRUBBER-EVM](#) [SI838XISO-KIT](#) [73931-3022](#) [XIO2200AEVM](#) [XIB-E](#) [XBIB-U-SP](#) [TW-DONGLE-USB](#) [EVAL-ADM2483EBZ](#) [EVAL-ADM2491EEBZ](#) [ATUSB-PCB-80146](#) [EVB-USB83340](#) [MAX9921EVKIT](#) [MAXREFDES23DB#](#) [MAX9291COAXEVKIT#](#) [MAX9286COAXEVKIT#](#) [MAX3535EEVKIT+](#) [MAX3223EEVKIT+](#) [MAX3100EVKIT](#) [MAX13235EEVKIT](#) [MAX14970EVKIT#](#) [MAX14826EVKIT#](#) [3298](#) [XR21B1424IV64-0A-EVB](#) [XR21B1421IL24-0A-EVB](#) [XTIB-U](#) [XR17D152CM-0A-EVB](#) [XR22802IL56-0A-EB](#)