



# RF Power Field Effect Transistors

## N-Channel Enhancement-Mode Lateral MOSFETs

Designed for pulse and CW wideband applications with frequencies up to 500 MHz. Devices are unmatched and are suitable for use in communications, radar and industrial applications.

- Typical Pulse Performance at 450 MHz:  $V_{DD} = 50$  Vdc,  $I_{DQ} = 150$  mA,  $P_{out} = 1000$  W Peak (200 W Avg.), Pulse Width = 100  $\mu$ sec, Duty Cycle = 20%  
 Power Gain — 20 dB  
 Drain Efficiency — 64%
- Capable of Handling 10:1 VSWR @ 50 Vdc, 450 MHz, 1000 W Peak Power

### Features

- Characterized with Series Equivalent Large-Signal Impedance Parameters
- CW Operation Capability with Adequate Cooling
- Qualified Up to a Maximum of 50  $V_{DD}$  Operation
- Integrated ESD Protection
- Designed for Push-Pull Operation
- Greater Negative Gate-Source Voltage Range for Improved Class C Operation
- In Tape and Reel. R5 Suffix = 50 Units, 56 mm Tape Width, 13-inch Reel.

**MMRF1006HR5**  
**MMRF1006HSR5**

**10-500 MHz, 1000 W, 50 V**  
**LATERAL N-CHANNEL**  
**BROADBAND**  
**RF POWER MOSFETs**

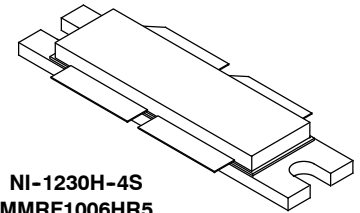

**NI-1230H-4S**  
**MMRF1006HR5**

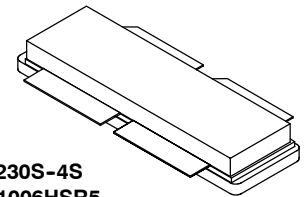

**NI-1230S-4S**  
**MMRF1006HSR5**

**PARTS ARE PUSH-PULL**

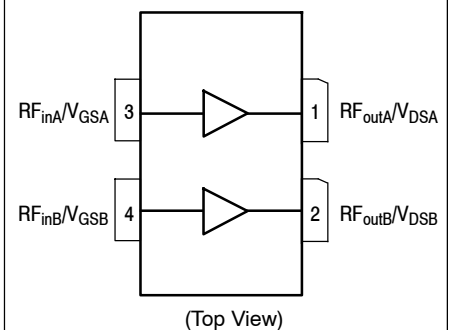

**Figure 1. Pin Connections**

**Table 1. Maximum Ratings**

Rating	Symbol	Value	Unit
Drain-Source Voltage	$V_{DSS}$	-0.5, +110	Vdc
Gate-Source Voltage	$V_{GS}$	-6, +10	Vdc
Storage Temperature Range	$T_{stg}$	-65 to +150	$^{\circ}$ C
Case Operating Temperature	$T_C$	150	$^{\circ}$ C
Operating Junction Temperature <sup>(1)</sup>	$T_J$	225	$^{\circ}$ C
Total Device Dissipation @ $T_C = 25^{\circ}$ C, CW only <sup>(2)</sup>	$P_D$	1333	W

1. Continuous use at maximum temperature will affect MTTF.

2. Refer to Fig. 12, Transient Thermal Impedance, for information to calculate value for pulsed operation.

**Table 2. Thermal Characteristics**

Characteristic	Symbol	Value <sup>(1)</sup>	Unit
Thermal Impedance, Junction to Case Pulse: Case Temperature 80°C, 1000 W Peak, 100 μsec Pulse Width, 20% Duty Cycle, 450 MHz <sup>(2)</sup>	Z <sub>θJC</sub>	0.03	°C/W
Thermal Resistance, Junction to Case CW: Case Temperature 84°C, 1000 W CW, 352.2 MHz	R <sub>θJC</sub>	0.15	°C/W

**Table 3. ESD Protection Characteristics**

Test Methodology	Class
Human Body Model (per JESD22-A114)	2, passes 2000 V
Machine Model (per EIA/JESD22-A115)	A, passes 125 V
Charge Device Model (per JESD22-C101)	IV, passes 2000 V

**Table 4. Electrical Characteristics** (T<sub>A</sub> = 25°C unless otherwise noted)

Characteristic	Symbol	Min	Typ	Max	Unit
----------------	--------	-----	-----	-----	------

**Off Characteristics <sup>(3)</sup>**

Gate-Source Leakage Current (V <sub>GS</sub> = 5 Vdc, V <sub>DS</sub> = 0 Vdc)	I <sub>GSS</sub>	—	—	10	μAdc
Drain-Source Breakdown Voltage (I <sub>D</sub> = 300 mA, V <sub>GS</sub> = 0 Vdc)	V <sub>(BR)DSS</sub>	110	—	—	Vdc
Zero Gate Voltage Drain Leakage Current (V <sub>DS</sub> = 50 Vdc, V <sub>GS</sub> = 0 Vdc)	I <sub>DSS</sub>	—	—	100	μAdc
Zero Gate Voltage Drain Leakage Current (V <sub>DS</sub> = 100 Vdc, V <sub>GS</sub> = 0 Vdc)	I <sub>DSS</sub>	—	—	5	mA

**On Characteristics**

Gate Threshold Voltage <sup>(3)</sup> (V <sub>DS</sub> = 10 Vdc, I <sub>D</sub> = 1600 μAdc)	V <sub>GS(th)</sub>	1	1.68	3	Vdc
Gate Quiescent Voltage <sup>(4)</sup> (V <sub>DD</sub> = 50 Vdc, I <sub>D</sub> = 150 mA, Measured in Functional Test)	V <sub>GS(Q)</sub>	1.5	2.2	3.5	Vdc
Drain-Source On-Voltage <sup>(3)</sup> (V <sub>GS</sub> = 10 Vdc, I <sub>D</sub> = 4 Adc)	V <sub>DS(on)</sub>	—	0.28	—	Vdc

**Dynamic Characteristics <sup>(3)</sup>**

Reverse Transfer Capacitance (V <sub>DS</sub> = 50 Vdc ± 30 mV(rms)ac @ 1 MHz, V <sub>GS</sub> = 0 Vdc)	C <sub>rss</sub>	—	3.3	—	pF
Output Capacitance (V <sub>DS</sub> = 50 Vdc ± 30 mV(rms)ac @ 1 MHz, V <sub>GS</sub> = 0 Vdc)	C <sub>oss</sub>	—	147	—	pF
Input Capacitance (V <sub>DS</sub> = 50 Vdc, V <sub>GS</sub> = 0 Vdc ± 30 mV(rms)ac @ 1 MHz)	C <sub>iss</sub>	—	506	—	pF

**Functional Tests <sup>(4)</sup>** (In Freescale Test Fixture, 50 ohm system) V<sub>DD</sub> = 50 Vdc, I<sub>DQ</sub> = 150 mA, P<sub>out</sub> = 1000 W Peak (200 W Avg.), f = 450 MHz, 100 μsec Pulse Width, 20% Duty Cycle

Power Gain	G <sub>ps</sub>	19	20	22	dB
Drain Efficiency	η <sub>D</sub>	60	64	—	%
Input Return Loss	IRL	—	-18	-9	dB

1. Refer to AN1955, *Thermal Measurement Methodology of RF Power Amplifiers*. Go to <http://www.freescale.com/rf>. Select Documentation/Application Notes – AN1955.
2. Refer to Fig. 12, Transient Thermal Impedance, for other pulsed conditions.
3. Each side of device measured separately.
4. Measurement made with device in push-pull configuration.

(continued)

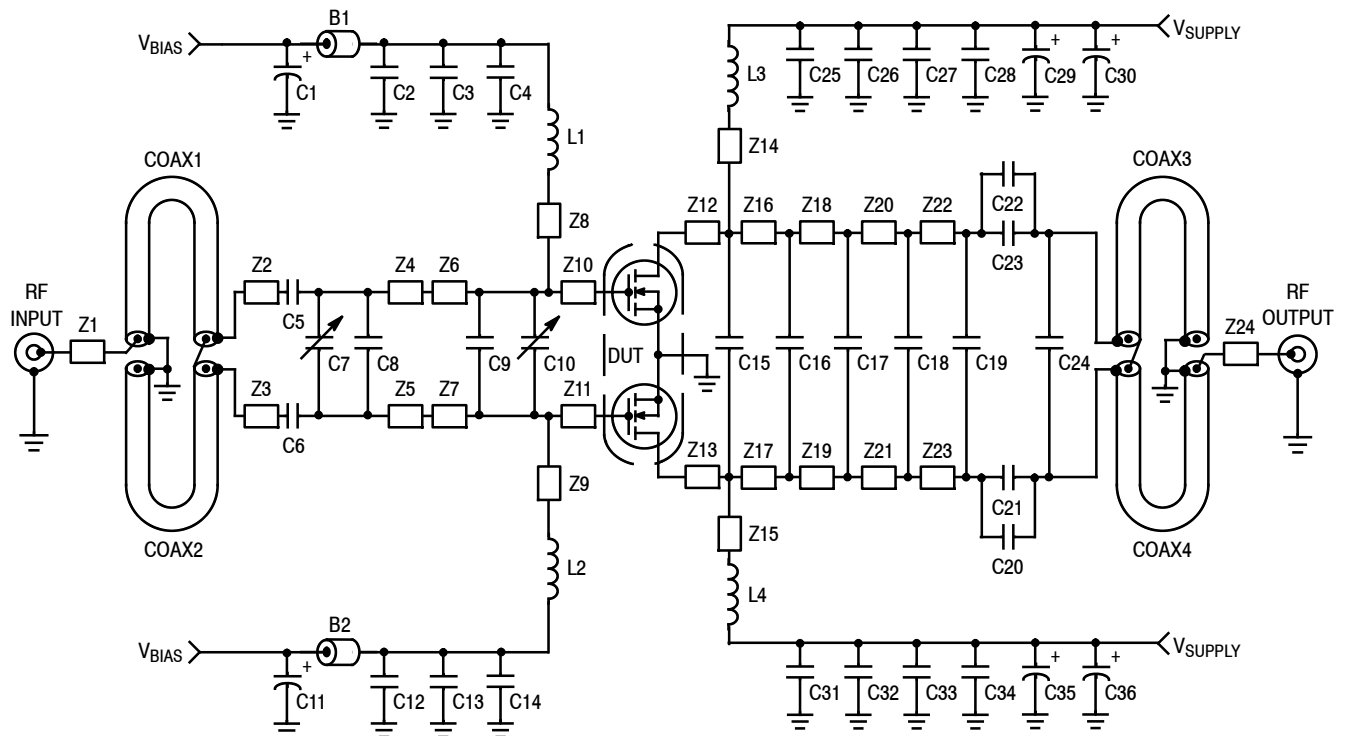

Z1	0.366" x 0.082" Microstrip	Z14*, Z15*	0.764" x 0.150" Microstrip
Z2*, Z3*	0.170" x 0.100" Microstrip	Z16, Z17	0.290" x 0.430" Microstrip
Z4*, Z5*	0.220" x 0.451" Microstrip	Z18, Z19	0.100" x 0.430" Microstrip
Z6, Z7	0.117" x 0.726" Microstrip	Z20, Z21, Z22, Z23	0.080" x 0.430" Microstrip
Z8*, Z9*	0.792" x 0.058" Microstrip	Z24	0.257" x 0.215" Microstrip
Z10, Z11	0.316" x 0.726" Microstrip	PCB	Arlon CuClad 250GX-0300-55-22, 0.030", $\epsilon_r = 2.55$
Z12, Z13	0.262" x 0.507" Microstrip		

\* Line length includes microstrip bends

Figure 2. MMRF1006HR5(HSR5) Pulse Test Circuit Schematic — 450 MHz

Table 5. MMRF1006HR5(HSR5) Pulse Test Circuit Component Designations and Values — 450 MHz

Part	Description	Part Number	Manufacturer
B1, B2	47 $\Omega$ , 100 MHz Short Ferrite Beads	2743019447	Fair-Rite
C1, C11	47 $\mu$ F, 50 V Electrolytic Capacitors	476KXM063M	Illinois
C2, C12, C28, C34	0.1 $\mu$ F Chip Capacitors	CDR33BX104AKYS	Kemet
C3, C13, C27, C33	220 nF, 50 V Chip Capacitors	C1812C224K5RAC	Kemet
C4, C14	2.2 $\mu$ F, 50 V Chip Capacitors	C1825C225J5RAC	Kemet
C5, C6, C8, C15	27 pF Chip Capacitors	ATC100B270JT500XT	ATC
C7, C10	0.8–8.0 pF Variable Capacitors	27291SL	Johanson Components
C9	33 pF Chip Capacitor	ATC100B330JT500XT	ATC
C16	12 pF Chip Capacitor	ATC100B120JT500XT	ATC
C17	10 pF Chip Capacitor	ATC100B100JT500XT	ATC
C18	9.1 pF Chip Capacitor	ATC100B9R1CT500XT	ATC
C19	8.2 pF Chip Capacitor	ATC100B8R2CT500XT	ATC
C20, C21, C22, C23, C25, C32	240 pF Chip Capacitors	ATC100B241JT200XT	ATC
C24	5.6 pF Chip Capacitor	ATC100B5R6CT500XT	ATC
C26, C31	2.2 $\mu$ F, 100 V Chip Capacitors	2225X7R225KT3AB	ATC
C29, C30, C35, C36	330 $\mu$ F, 63 V Electrolytic Capacitors	EMVY630GTR331MMH0S	Nippon Chemi-Con
Coax1, 2, 3, 4	25 $\Omega$ Semi Rigid Coax, 2.2" Shield Length	UT-141C-25	Micro-Coax
L1, L2	2.5 nH, 1 Turn Inductors	A01TKLC	Coilcraft
L3, L4	43 nH, 10 Turn Inductors	B10TJLC	Coilcraft

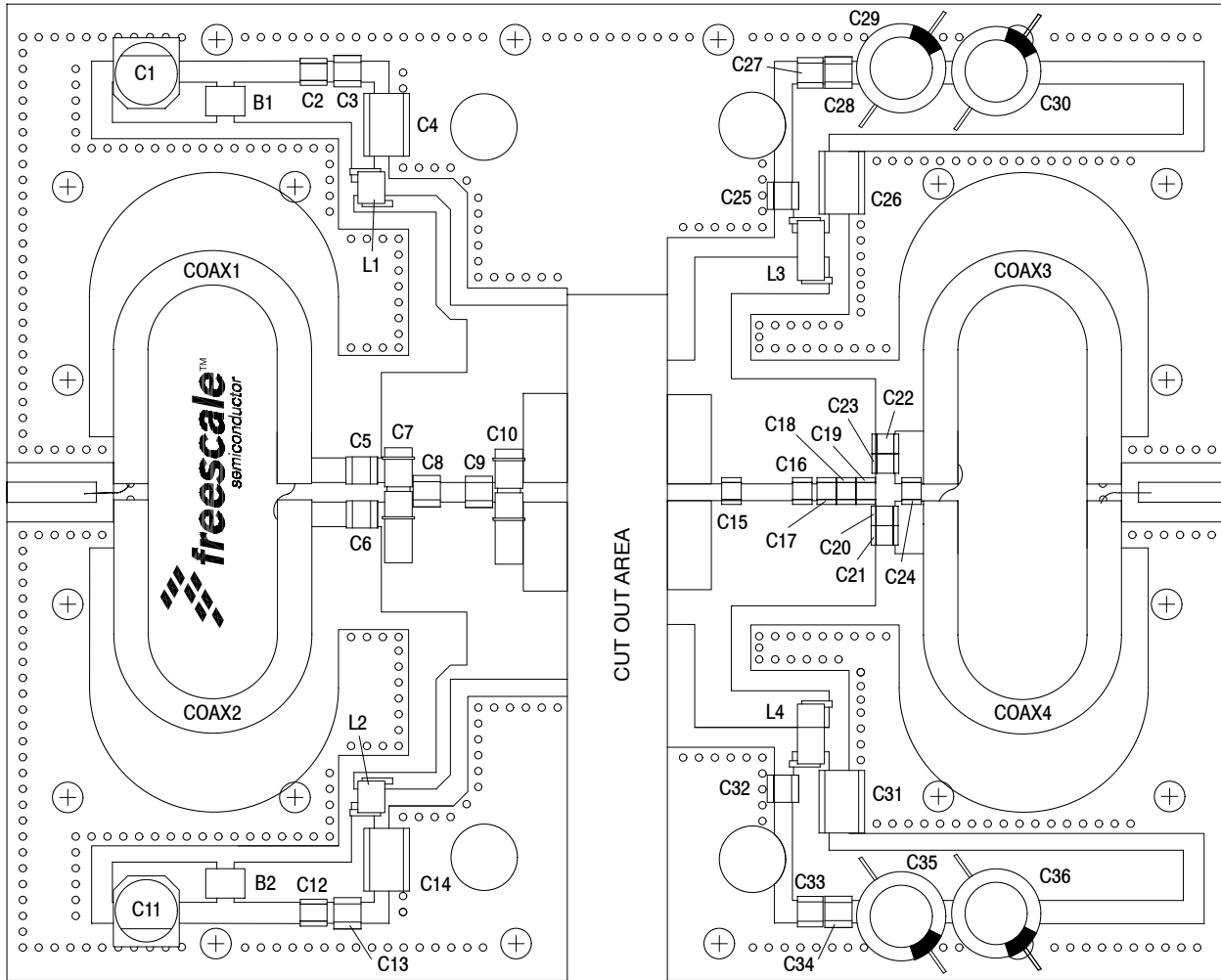
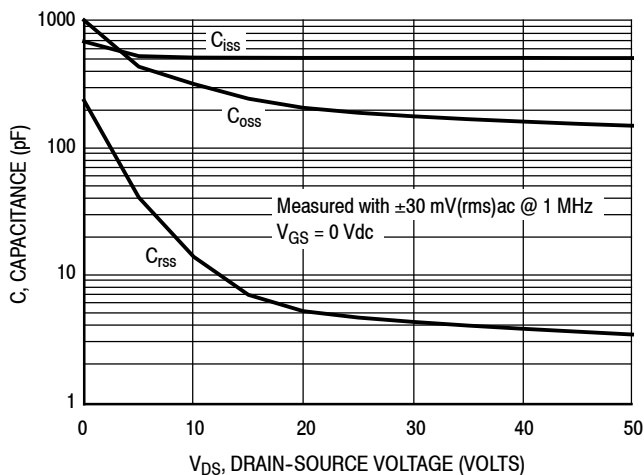
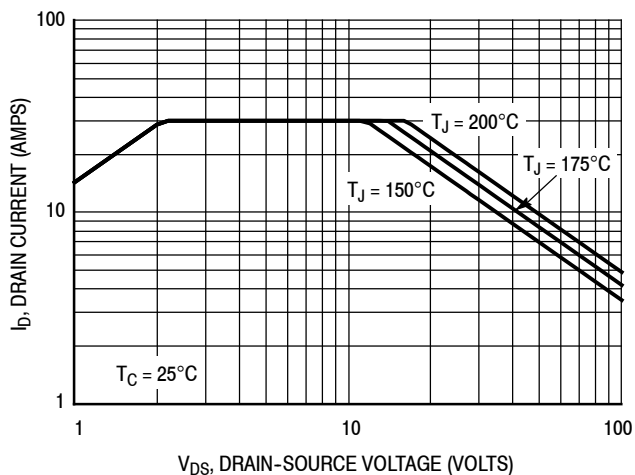

Figure 3. MMRF1006HR5(HSR5) Pulse Test Circuit Component Layout — 450 MHz

## TYPICAL CHARACTERISTICS



**Note:** Each side of device measured separately.  
**Figure 4. Capacitance versus Drain-Source Voltage**



**Note:** Each side of device measured separately.  
**Figure 5. DC Safe Operating Area**

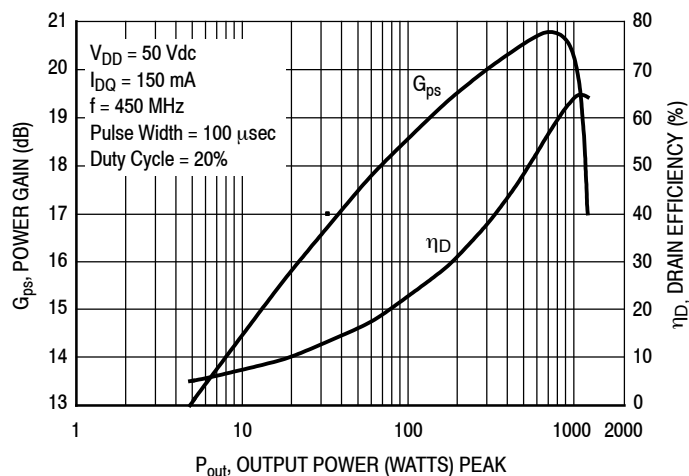

**Figure 6. Power Gain and Drain Efficiency versus Output Power**

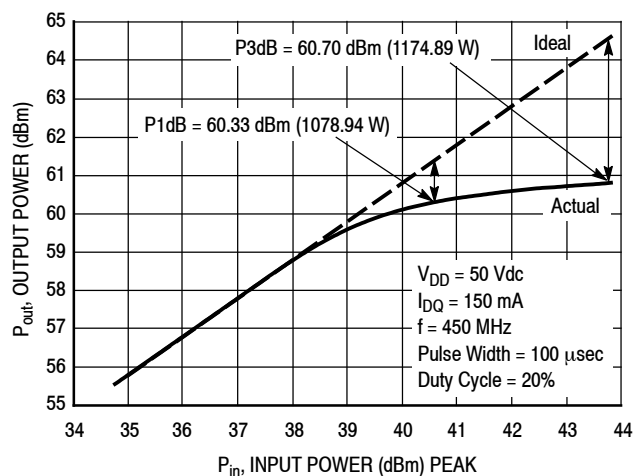

**Figure 7. Output Power versus Input Power**

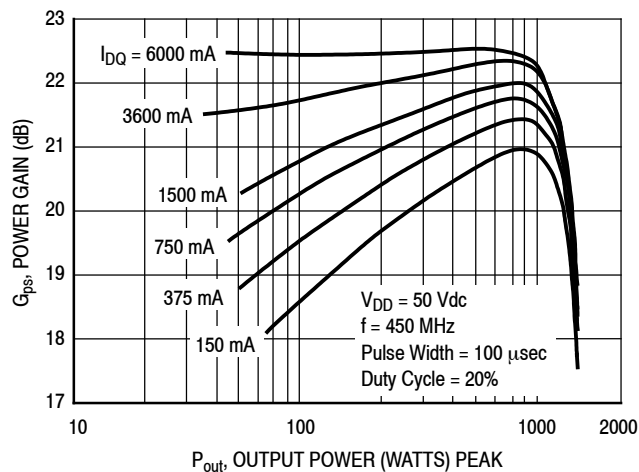

**Figure 8. Power Gain versus Output Power**

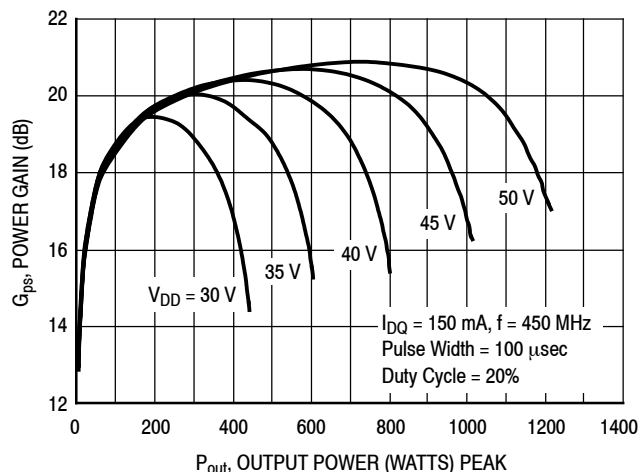

**Figure 9. Power Gain versus Output Power**

## TYPICAL CHARACTERISTICS

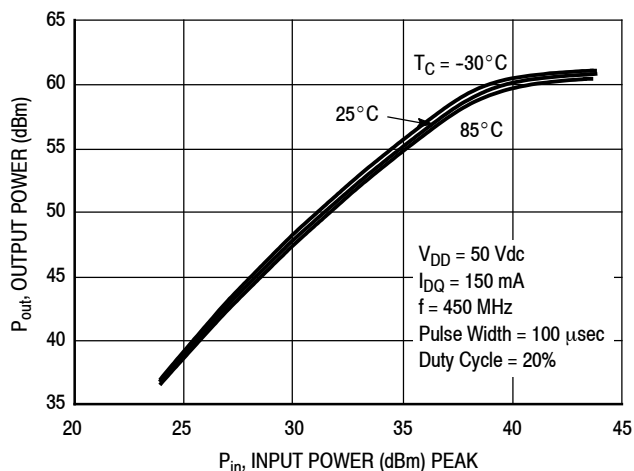

Figure 10. Output Power versus PEAK Input Power

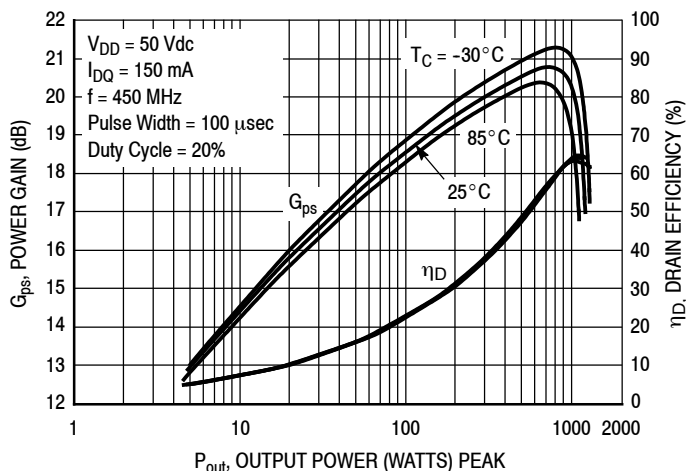

Figure 11. Power Gain and Drain Efficiency versus Output Power

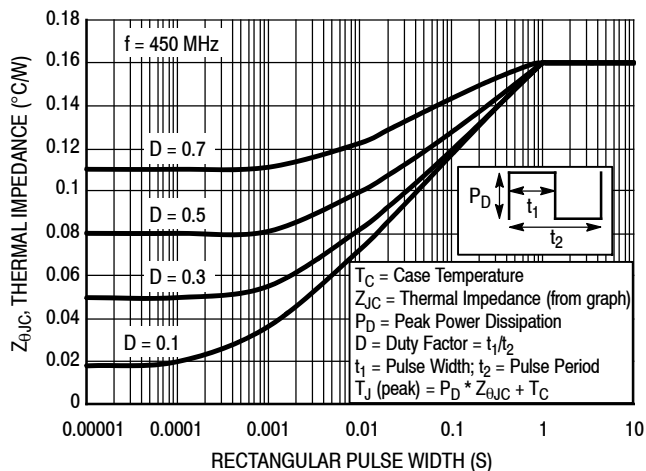
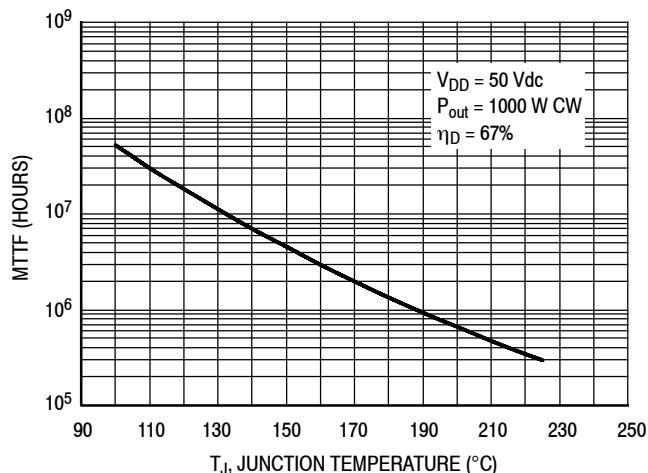

Figure 12. Transient Thermal Impedance



MTTF calculator available at <http://www.freescale.com/rf>. Select Software & Tools/Development Tools/Calculators to access MTTF calculators by product.

NOTE: For pulse applications or CW conditions, use the MTTF calculator referenced above.

Figure 13. MTTF versus Junction Temperature - CW

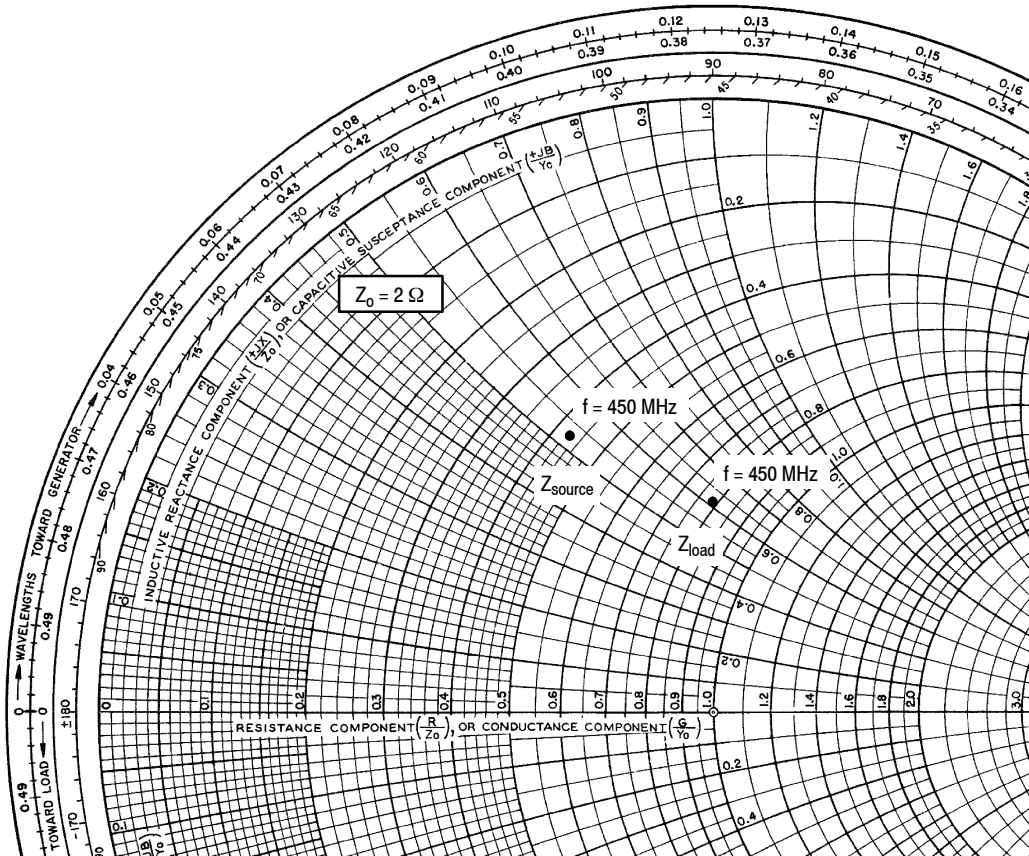

$V_{DD} = 50 \text{ Vdc}$ ,  $I_{DQ} = 150 \text{ mA}$ ,  $P_{out} = 1000 \text{ W Peak}$

f MHz	$Z_{source}$ $\Omega$	$Z_{load}$ $\Omega$
450	$0.86 + j1.06$	$1.58 + j1.22$

$Z_{source}$  = Test circuit impedance as measured from gate to gate, balanced configuration.

$Z_{load}$  = Test circuit impedance as measured from drain to drain, balanced configuration.

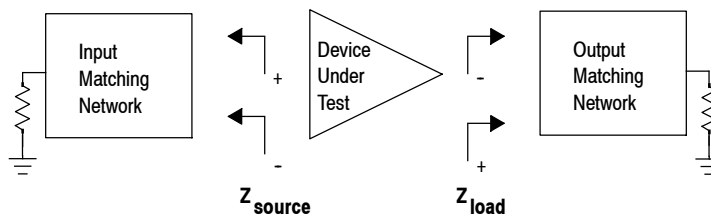
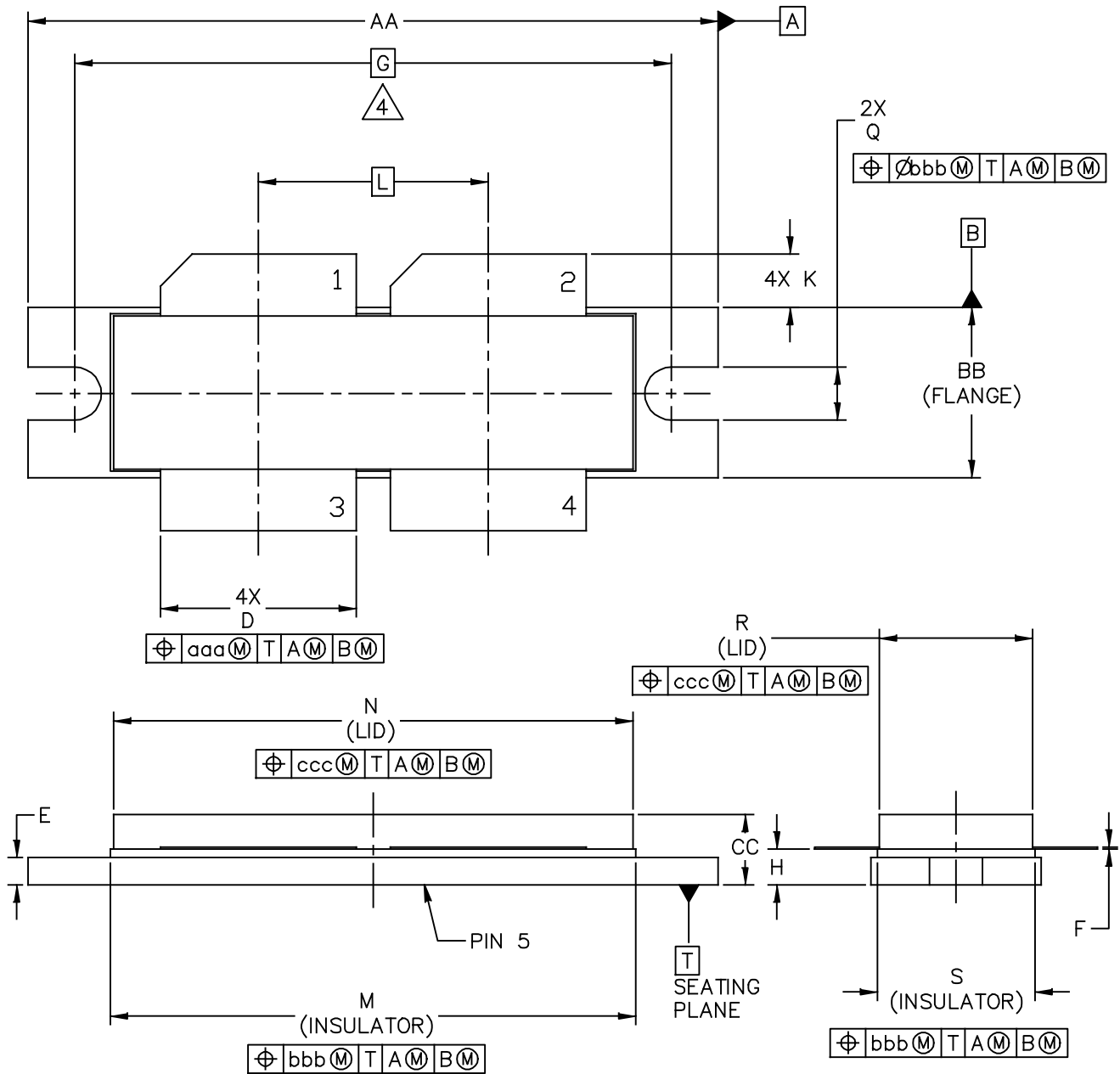

Figure 14. Series Equivalent Source and Load Impedance — 450 MHz

### PACKAGE DIMENSIONS



© FREESCALE SEMICONDUCTOR, INC. ALL RIGHTS RESERVED.	MECHANICAL OUTLINE	PRINT VERSION NOT TO SCALE
TITLE:  <div style="text-align: center; font-size: 1.2em;">NI-1230-4H</div>	DOCUMENT NO: 98ASB16977C      REV: F	
		STANDARD: NON-JEDEC
		28 FEB 2013



NOTES:

1. INTERPRET DIMENSIONS AND TOLERANCES PER ASME Y14.5M-1994.
2. CONTROLLING DIMENSION: INCH
3. DIMENSION H IS MEASURED .030 INCH (0.762 MM) AWAY FROM PACKAGE BODY.
4. RECOMMENDED BOLT CENTER DIMENSION OF 1.52 INCH (38.61 MM) BASED ON M3 SCREW.

DIM	INCH		MILLIMETER		DIM	INCH		MILLIMETER	
	MIN	MAX	MIN	MAX		MIN	MAX	MIN	MAX
AA	1.615	1.625	41.02	41.28	N	1.218	1.242	30.94	31.55
BB	.395	.405	10.03	10.29	Q	.120	.130	3.05	3.30
CC	.170	.190	4.32	4.83	R	.355	.365	9.02	9.27
D	.455	.465	11.56	11.81	S	.365	.375	9.27	9.53
E	.062	.066	1.57	1.68					
F	.004	.007	0.10	0.18					
G	1.400 BSC		35.56 BSC		aaa	.013		0.33	
H	.082	.090	2.08	2.29	bbb	.010		0.25	
K	.117	.137	2.97	3.48	ccc	.020		0.51	
L	.540 BSC		13.72 BSC						
M	1.219	1.241	30.96	31.52					
© FREESCALE SEMICONDUCTOR, INC. ALL RIGHTS RESERVED.			MECHANICAL OUTLINE			PRINT VERSION NOT TO SCALE			
TITLE:					DOCUMENT NO: 98ASB16977C      REV: F				
NI-1230-4H					STANDARD: NON-JEDEC				
					28 FEB 2013				

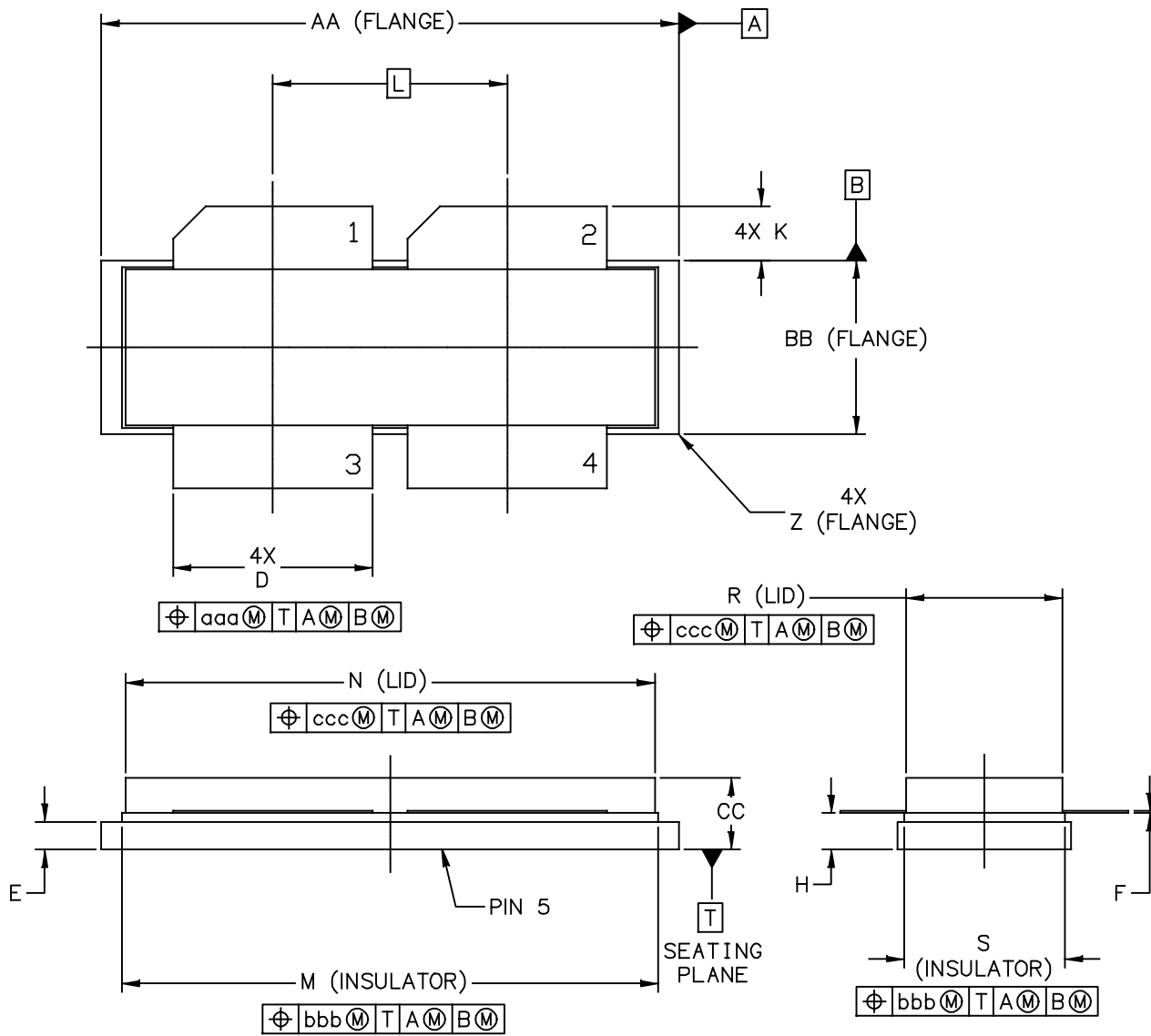

© FREESCALE SEMICONDUCTOR, INC. ALL RIGHTS RESERVED.	MECHANICAL OUTLINE	PRINT VERSION NOT TO SCALE
TITLE:  NI-1230-4S	DOCUMENT NO: 98ARB18247C	REV: G
	STANDARD: NON-JEDEC	
	01 MAR 2013	

NOTES:

1. INTERPRET DIMENSIONS AND TOLERANCES PER ASME Y14.5M-1994.
2. CONTROLLING DIMENSION: INCH
3. DIMENSION H IS MEASURED .030 INCH (0.762 MM) AWAY FROM PACKAGE BODY

DIM	INCHES		MILLIMETERS		DIM	INCHES		MILLIMETERS	
	MIN	MAX	MIN	MAX		MIN	MAX	MIN	MAX
AA	1.265	1.275	32.13	32.39	R	.355	.365	9.02	9.27
BB	.395	.405	10.03	10.29	S	.365	.375	9.27	9.53
CC	.170	.190	4.32	4.83	Z	R.000	R.040	R0.00	R1.02
D	.455	.465	11.56	11.81					
E	.062	.066	1.57	1.68	aaa	.013		0.33	
F	.004	.007	0.10	0.18	bbb	.010		0.25	
H	.082	.090	2.08	2.29	ccc	.020		0.51	
K	.117	.137	2.97	3.48					
L	.540 BSC		13.72 BSC						
M	1.219	1.241	30.96	31.52					
N	1.218	1.242	30.94	31.55					
© FREESCALE SEMICONDUCTOR, INC. ALL RIGHTS RESERVED.			MECHANICAL OUTLINE			PRINT VERSION NOT TO SCALE			
TITLE:					DOCUMENT NO: 98ARB18247C		REV: G		
NI-1230-4S					STANDARD: NON-JEDEC				
					01 MAR 2013				

## PRODUCT DOCUMENTATION

Refer to the following documents to aid your design process.

### Application Notes

- AN1955: Thermal Measurement Methodology of RF Power Amplifiers

### Engineering Bulletins

- EB212: Using Data Sheet Impedances for RF LDMOS Devices

## REVISION HISTORY

The following table summarizes revisions to this document.

Revision	Date	Description
0	Dec. 2013	• Initial Release of Data Sheet

### ***How to Reach Us:***

**Home Page:**  
[freescale.com](http://freescale.com)

**Web Support:**  
[freescale.com/support](http://freescale.com/support)

Information in this document is provided solely to enable system and software implementers to use Freescale products. There are no express or implied copyright licenses granted hereunder to design or fabricate any integrated circuits based on the information in this document.

Freescale reserves the right to make changes without further notice to any products herein. Freescale makes no warranty, representation, or guarantee regarding the suitability of its products for any particular purpose, nor does Freescale assume any liability arising out of the application or use of any product or circuit, and specifically disclaims any and all liability, including without limitation consequential or incidental damages. "Typical" parameters that may be provided in Freescale data sheets and/or specifications can and do vary in different applications, and actual performance may vary over time. All operating parameters, including "typicals," must be validated for each customer application by customer's technical experts. Freescale does not convey any license under its patent rights nor the rights of others. Freescale sells products pursuant to standard terms and conditions of sale, which can be found at the following address: [freescale.com/SalesTermsandConditions](http://freescale.com/SalesTermsandConditions).

Freescale and the Freescale logo are trademarks of Freescale Semiconductor, Inc., Reg. U.S. Pat. & Tm. Off. All other product or service names are the property of their respective owners.

© 2013 Freescale Semiconductor, Inc.



## X-ON Electronics

Largest Supplier of Electrical and Electronic Components

*Click to view similar products for [RF MOSFET Transistors](#) category:*

*Click to view products by [Freescale](#) manufacturer:*

Other Similar products are found below :

[MRF166W](#) [MHT1006NT1](#) [FH2164](#) [MRFE8VP8600HR5](#) [BLF245](#) [BLF278](#) [ARF1511](#) [ARF465BG](#) [BF 2030 E6814](#) [BLF861A](#) [3SK263-5-TG-E](#) [VRF154FL](#) [MRF6S20010GNR1](#) [DU1215S](#) [DU28200M](#) [VRF150MP](#) [MMRF1015NR1](#) [MRF154](#) [MRF175LU](#) [MRF6S20010GNR1](#) [UF28100M](#) [MW6S010GNR1](#) [MW6S010GNR1](#) [DU2820S](#) [SD2943W](#) [SD2932BW](#) [SD2941-10W](#) [MRF24301HR5](#) [ARF469AG](#) [ARF463BP1G](#) [MMRF1019NR4](#) [MHT1008NT1](#) [MMRF1014NT1](#) [MRF426](#) [MRF422](#) [BLW96](#) [ARF468AG](#) [VRF161MP](#) [ARF468BG](#) [MRFE6VP61K25NR6](#) [MRFE6VP5300NR1](#) [A2T27S020NR1](#) [MMRF1304NR1](#) [MRFE6S9060GNR1](#) [MMRF1008GHR5](#) [A2T27S007NT1](#) [AFT09MP055NR1](#) [DU2860U](#) [MHT1803A](#) [D2081UK.F](#)