



Technical data sheet

Converter USB/RS-232 to RS-285/422

COTER-U4N

COTER-U4I

COTER-24N

COTER-24I



Document version: COTER-man-en-v7

Modification date: 2008-12-05

<http://www.netronix.pl>

Index of contents

- 1. Technical data3
- 2. Controls3
- 3. Layout of elements in housing3
- 4. Electric diagram4
- 5. Modes of operation4
- 6. Start-up and configuration5
- 7. Updating the software5
- 8. Description of terminal signals.....5
- 9. Electrical data7

Index of tables

- Table 1: Housing elements.4
- Table 2: Signals in RS-232 interface.....6
- Table 3: Signals in RJ-12 jack.....6
- Table 4: Electrical data.7

Illustration index

- Illustration 1: Housing elements.....3
- Illustration 2: An example of electric connection diagram.4
- Illustration 3: RS-232 interface connector.....6
- Illustration 4: RJ-12 jack.7

1. Technical data

The COTER converter has been designed to provide bidirectional signal conversion of selected interface:

- COTER-24N converter for RS-232 to RS-485/RS-422 without galvanic isolation.
- COTER-24I converter for RS-232 to RS-485/RS-422 with galvanic isolation.
- COTER-U4N converter for USB to RS-485/RS-422 without galvanic isolation.
- COTER-U4I converter for USB to RS-485/RS-422 with galvanic isolation.

The converter features automatic baud-rate detection mode. It is possible to set specified baud-rate for 1200 bps to 115200 bps manually or control transmitting by RTS signal. The converter can operate in service mode in which is possible to update software by NEFIR program available on NETRONIX website.

2. Controls

- **1 RS-232/USB port**
 - Transmitting and receiving data from RS-485/RS-422 interface.
 - For configuration and update of software in service mode.
- **1 RS-485/422 port**
 - Configurable RS-485 mode, baud-rate of 1200 to 115200 bps, AUTO, RTS or RS-422 modes.
- **“Supply” LED**
- **“Status” LED** – indicates device state (see: [Configuration](#) chapter).
 - Indicates data transmission on serial interface.
- **"User" switch** – for setting the converter mode (see [Configuration](#) chapter).

3. Layout of elements in housing

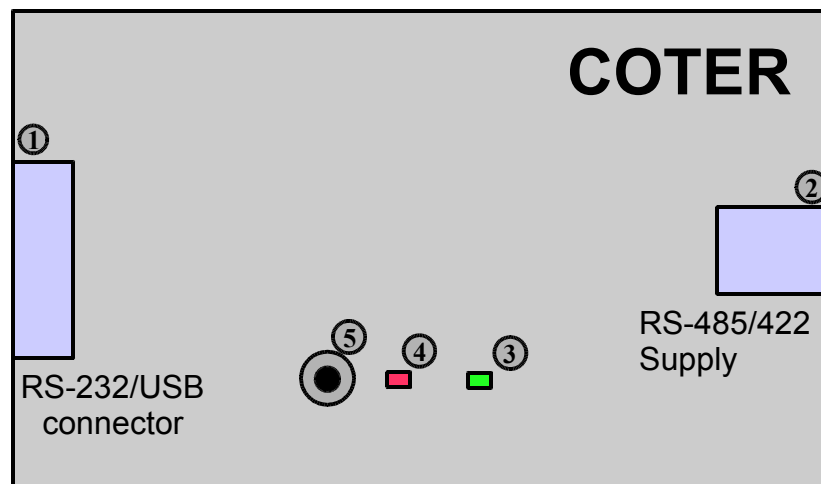

Illustration 1: Housing elements.

Table 1: Housing elements.

No.	Name	Description
1	RS-232 terminal / USB ⁽¹⁾	DB9 / USB B type
2	RS-485/422 terminal / supply ⁽²⁾	RJ-12 (supply voltage: +7 to +16V DC 300mA max).
3	“Supply” LED	Green
4	“Status” LED	Red
5	User switch	

Note:

(1) Depending on the device version (see chapter: [Technical data](#)).

(2) In device COTER-U4N supply input is not connected (device is powered from USB).

4. Electric diagram

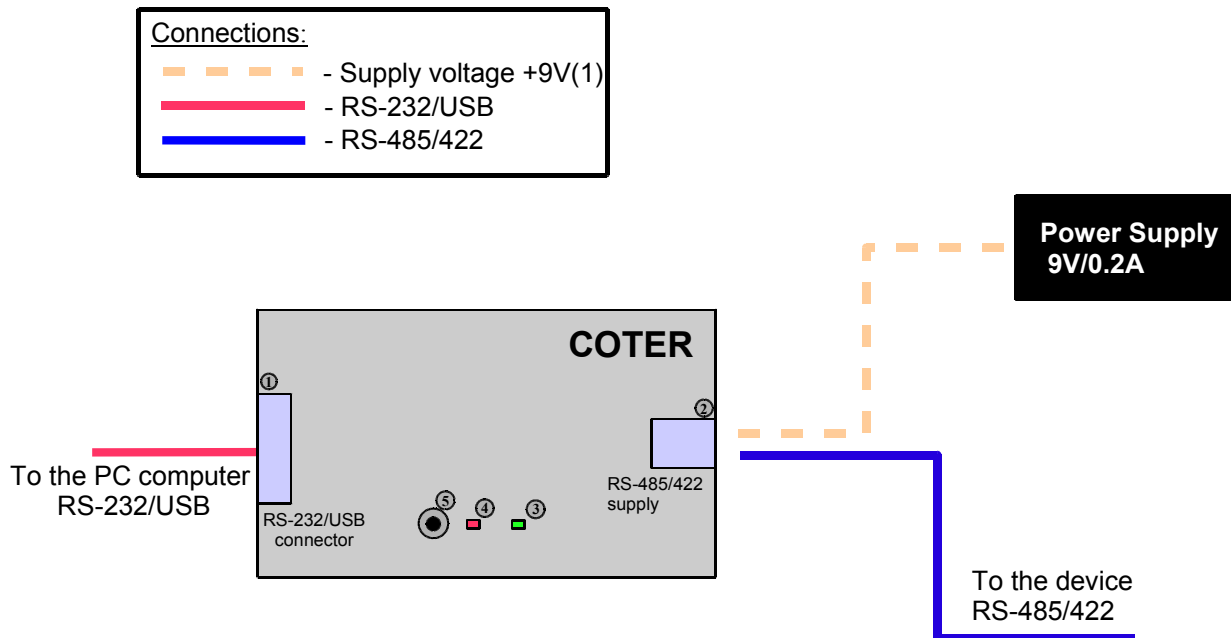

Illustration 2: An example of electric connection diagram.

Note:

(1) Converter version COTER-U4N is powered from PC USB port, external power input should not be connected.

5. Modes of operation

The converter can operate in various modes, which are described below:

1. **AUTOMATIC** – baud rate in this mode is detected on basis data transmitted via RS-232 interface. The baud rate change for lower to higher is performed immediately. The baud rate set to lower is detected properly, after 16 transmission cycles, because baud rate changing during transmission from higher to lower transmission errors may occur.
2. **1200** – baud rate of 1200 bps, fixed.
3. **2400** – baud rate of 2400 bps, fixed.

4. **4800** – baud rate of 4800 bps, fixed.
5. **9600** – baud rate of 9600 bps, fixed.
6. **19200** – baud rate of 19200 bps, fixed.
7. **38400** – baud rate of 38400 bps fixed.
8. **57600** – baud rate of 57600 bps, fixed.
9. **115200** – baud rate of 115200 bps, fixed.
10. **RTS** – transmitting via RS-485 lines, controlling via RTS line only.
11. **RS-422** – interface RS-422 is enable, lines TX+/- are set for transmitting data, lines RX+/- are set for receiving.
12. **SERVICE** – in this mode it is possible to test device firmware by NETRONIX protocol and update the firmware using NEFIR application, which is available on NETRONIX website. In this mode it is possible to communicate with a device at transmission settings 9600bps 8-N-1.

Note:

In service mode the converter does not transmit data which is sent via RS-232 lines to RS-485/422 and vice versa. In this mode RS-485/422 line are isolated completely.

6. Start-up and configuration

Mode changing can be performed by means of user switch (see illustration 1). To establish proper converter mode, push the switch number of times required for achieving desired mode of operation. To set a mode properly, push the switch not more, than 5 times per second. After ca. 1 second since last push, converter will display detected mode, switching on and off the status diode with ca. 1 second cycle. Service mode message is displayed during five swift LED flashings. In case of erratic number input, converter will light-up status LED with one long pulse, and will remain in the mode set before. At power on, the converter is set in last used mode of operation automatically.

Work with USB interface run in the same way as with RS-232 interface. Converter is detected as a serial port so there is no need to use any specific drivers upon communication. In case of problem with automatic driver installation, drivers can be downloaded from [FT232R](http://www.ftdichip.com/FT232R.htm) chipset producer site.

7. Updating the software

During update of converter firmware user simply saves coter-x4-vx.nhex file supplied by manufacturer using NEFIR program.

Update method:

1. Connect RS-232 / USB port to computer.
2. Enable service mode of the converter. Be sure, that the mode has been set properly; otherwise data will be sent to RS-485 port.
3. Run NEFIR program and load firmware file. Loading program begins loading of new firmware automatically. After loading procedure is completed, device is reset and set into AUTO mode.

8. Description of terminal signals

Illustrations below show front of terminals connectors.

RS-232 interface

Table 2: Signals in RS-232 interface.

Pin	Name	Description
1	-	Non connected
2	TX	Converter output
3	RX	Converter input
4	-	Non connected
5	GND	Transmitter ground
6	-	Non connected
7	RTS	Converter input
8	CTS	Converter output
9	-	Non connected

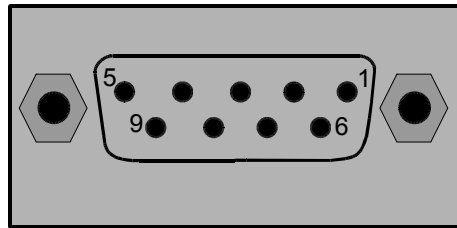

Illustration 3: RS-232 interface connector.

RJ-12 jack

Table 3: Signals in RJ-12 jack.

Pin	Name	Description
1	+7...+16V DC ⁽¹⁾	DC voltage +7...+16V, max. current consumption 0,3 A
2	GND	Supply ground
3	TX+/A	“TX+” wire for RS-422 or “A” (+) wire for RS-485
4	TX-/B	“TX-” wire for RS-422 or “B” (-) wire for RS-485
5	RX+	“RX+” wire for RS-422
6	RX-	“RX-” wire for RS-422

Note:

(1) Not applied to COTER-U4N (Non connected).

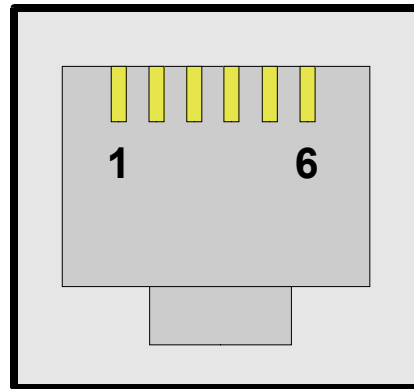

Illustration 4: RJ-12 jack.

9. Electrical data

Table 4: Electrical data.

Nr	Symbol	Features	Value			Unit	Notes
			Min.	Typ.	Max.		
Supply parameters							
1	Vpower ⁽¹⁾	Supply voltage	+7.0	+9,0	+16,0	V	Notes:
2	Ipower ⁽²⁾	Supply current consumption	50	130	300	mA	Depending on converter version
RS-232 port parameters							
3	Vrs232_out ⁽²⁾	Input voltage fluctuation range for TX/CTS line	-	±10,0	-	V	Without load
4	Vrs232_in ⁽²⁾	Max. input voltage fluctuation range for RX/RT lines	-	-	±30,0	V	-
RS-485/422 port parameters							
5	Vrs485/422_out	Differential output voltage range abs(A-B)	1,5	2,7	5,0	V	-
6	Vrs485/422_in	Differential input voltage range A-B	-	-	±14	V	-

Notes:

(1) Supply voltage should be stabilized.

(2) Not applied to COTER-U4N.

Latest news concerning to NETRONIX products
<http://www.netronix.pl/>

X-ON Electronics

Largest Supplier of Electrical and Electronic Components

Click to view similar products for [RF Modules](#) category:

Click to view products by [Netronix](#) manufacturer:

Other Similar products are found below :

[HMC-C009](#) [HMC-C011](#) [nRF24L01P-MODULE-PCB](#) [HMC-C021](#) [HMC-C024](#) [XB9XT-DPRS-721](#) [XBP9B-DMUTB022](#) [nRF24L01P-MODULE-SMA](#) [CMD-KEY2-418-CRE](#) [XM-C92-2P-UA](#) [XB9XT-DPUS-721](#) [V640-A90](#) [HMC-C583](#) [MAAM-008818-TR3000](#) [MTSMC-H5-U](#) [SIMSA868-PRO](#) [SIMSA915C-PRO](#) [SIMSA868C-PRO](#) [SIMSA433C-PRO](#) [SIMSA915-PRO](#) [XBP9B-DMUT-042](#) [HMC-C582](#) [HMC-C022](#) [XBP9B-DPST-041](#) [XBP9B-DMWT-042](#) [SM-MN-00-HF-RC](#) [HMC-C031](#) [MT-02](#) [M1002GB](#) [702-W](#) [SIMSA868C-N-PRO](#) [SIMSA433C-N-PRO](#) [SIMSA915C-N-PRO](#) [ADP-R202-00B](#) [PEPPER WIRELESS C1 USB](#) [S2-10732-Z1T61](#) [S2-107XB-Z2356-Z2352](#) [S2-10672-Z1L85](#) [S2-10686-Z1L1D](#) [S2-10688-Z1L1T](#) [S2-106BA-Z1P20](#) [S2-1060C-Z1F0A](#) [S2-106R4-Z1Q6F-Z1Q6Q](#) [S2-106R4-Z1Q6J-Z1Q6Q](#) [S2-106RB-Z1Q6V-Z1Q6Q](#) [S2-107DR-Z1Y5B](#) [SU60-2230C-PU](#) [RC-TFSK3-868](#) [NANO RFID POE](#) [RFID USB POCKET](#)