

T5321, T5322, T5323, T5324
T5421, T5422, T5423, T5424
5X7 mm Surface Mount High Reliability
Tristate/Non-Tristate, 1 MHz to 100MHz

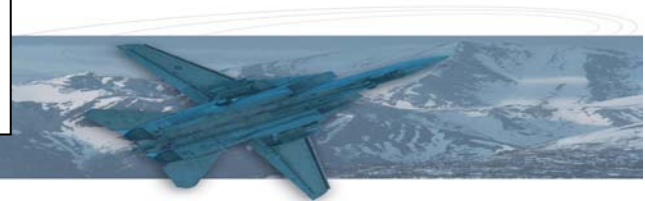

Hi-Reliability Product Specification

XO

Features

- Leadless chip carrier package is hermetically sealed for superior aging and field performance
- Crystal angle controlled to +/- 1 minute for excellent temperature stability
- 168 hour Class B burn-in and extensive environmental testing for best performance in rugged field environments
- Start-up time less than 10 ms, typical
- Tristate option available
- Calculated MTBF is 3.8×10^6 hours at 125°C

Typical Applications

- Surface Mounted PCB projects requiring high reliability HCMOS clock waveforms

Description

These high reliability oscillators provide HCMOS clock waveforms for applications subjected to the most stringent environmental conditions. They are mechanically robust and weigh less than 0.2 grams. This 5X7 mm SMD package has a hermetic seal, thus ensuring the integrity of each oscillator. Each oscillator is burned-in at 125°C for 168 hours, temperature cycled and centrifuged then fully tested in accordance with Table 1. Reliability tests are performed per Table 2. The calculated MTBF is 3.8×10^6 at 125°C.

Models	Operating Temperature	Frequency Stability
T5321	-55 to + 85°C	+/- .0025% (+/- 25ppm)
T5322	-55 to + 85°C	+/- .005% (+/- 50ppm)
T5323	-55 to + 125°C	+/- .0075% (+/- 75ppm)
T5324	-55 to + 125°C	+/- .005% (+/- 50ppm)
T5421	-55 to + 85°C	+/- .0025% (+/- 25ppm)
T5422	-55 to + 85°C	+/- .005% (+/- 50ppm)
T5423	-55 to + 125°C	+/- .0075% (+/- 75ppm)
T5424	-55 to + 125°C	+/- .005% (+/- 50ppm)

Connections

Pad	T5321, T5322, T5323, T5324	T5421, T5422, T5423, T5424
1.	N.C.	Tristate
2.	Ground	Ground
3.	Output	Output
	+3.3V, V _{DD}	+3.3V, V _{DD}

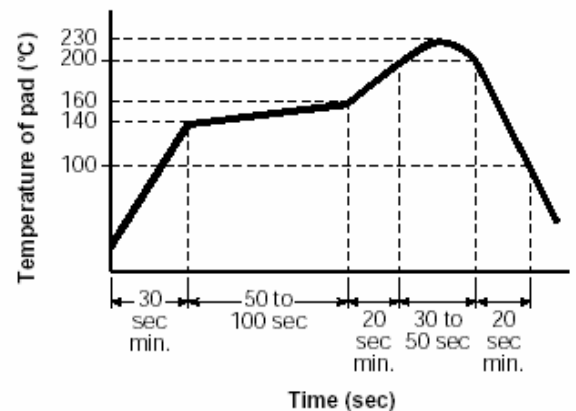
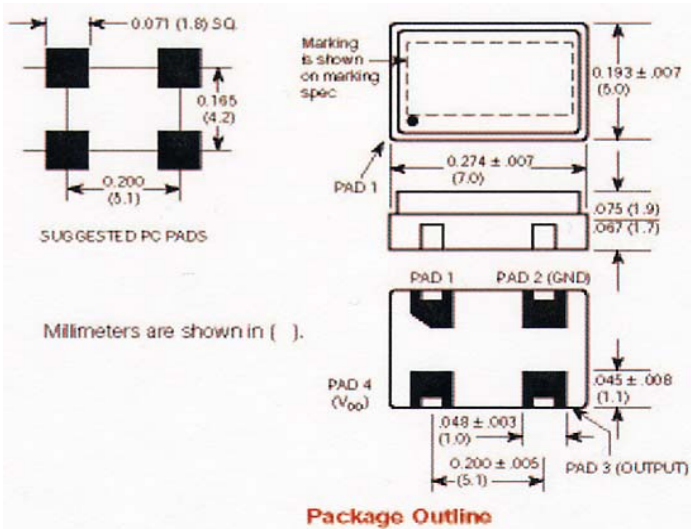

Recommended Reflow Soldering Profile

T5321, T5322, T5323, T5324
T5421, T5422, T5423, T5424
5X7 mm Surface Mount High Reliability
Tristate/Non-Tristate, 1 MHz to 100MHz



ELECTRICAL SPECIFICATIONS

Frequency Range
 Fixed Output 1 MHz to 100MHz
Frequency Stability Includes calibration at 25°C, operating temperature, change of input voltage, change of load, shock and vibration.

	MIN	TYP	MAX	
UNITS				
Input Voltage, V_{DD}	3.0	3.3	3.6	volts
Input Current			16	mA
Waveform Symmetry, Measured at 50%V _{DD}	40/60	45/55	60/40	percent
Rise and Fall Time				
CMOS, 15 pf, 20 to 80% (<60 MHz)		3.0	4.0	ns
20 to 80% (≥60 MHz)		2.0	2.5	ns
CMOS, 30 pf, 20 to 80% (<60 MHz)		4.0	5.0	ns
20 to 80% (≥60 MHz)		3.0	4.5	ns

“Zero” Level,
 Sinking 16 mA 0.4 volts

“One” Level
 Sourcing 8 mA V_{DD}-0.4V volts

Aging
 First year 3 ppm
 After first year 1 ppm/yr

Input Requirements for Pin 1.:

THERMAL CHARACTERISTICS

Thermal Resistance
 From Junction to Case, R_{θjc} 16 °C/Watt

SURFACE MOUNT APPLICATION

These packages are designed for reflow soldering in accordance with recommended profiles. For hand-soldering, the temperature of the iron should not exceed 400°C for three seconds.

ENVIRONMENTAL SPECIFICATIONS

Shock-1000 Gs, 0.35 ms, ½ sine wave, 3 shocks in each plane
Vibration-10-2000 Hz of .06” d.a. or 20Gs, whichever is less
Humidity-Resistant to 85° R.H. at 85°C

Table 1

Each unit undergoes the following:

1. Stabilization Bake MIL-STD-883 Method 1008, Cond.,B
2. Temperature Cycling MIL-STD-883 Method 1010, Cond, B
3. Constant Acceleration MIL-STD-883 Method 2001, Cond, A
4. Burn-in MIL-STD-883 Method 1015, Cond B (125°C for 168 hours with bias)
5. Fine Leak MIL-STD-883 Method 1014, Cond. A1
6. Gross Leak MIL-STD-883 Method 1014, Cond C
7. Electrical Test at 25°C and temperature extremes, as follows:

- | | |
|---------------|-----------------------|
| A. Frequency | F. Duty Cycle |
| B. Current | G. Frequency at 3.6V |
| C. Rise Time | H. Frequency at 3.0V |
| D. Fall Time | I. “Zero” logic level |
| E. Duty Cycle | J. “One” logic level |
| | K. Tristate |

Test Data on each unit is available for additional cost

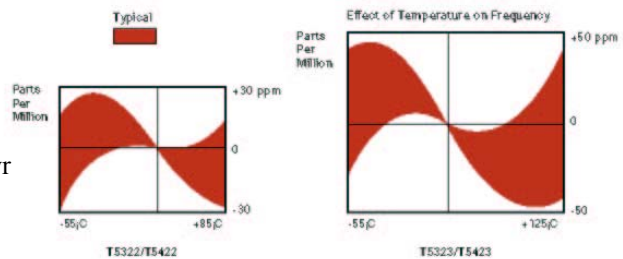

T5321, T5322, T5323, T5324
T5421, T5422, T5423, T5424
5X7 mm Surface Mount High Reliability
Tristate/Non-Tristate, 1 MHz to 100MHz



MECHANICAL SPECIFICATIONS

- Leak**-MIL STD 883, Method 1014, Condition A1 and C1
- Case**-Hermetically sealed ceramic LCC
- Pads**-60 microinch of gold over nickel
- Resistance to Solvents**-MIL STD 202, Method 215
- Marking**-Epoxy ink or laser engraved

MARKING SPECIFICATION

The format for the marking is:

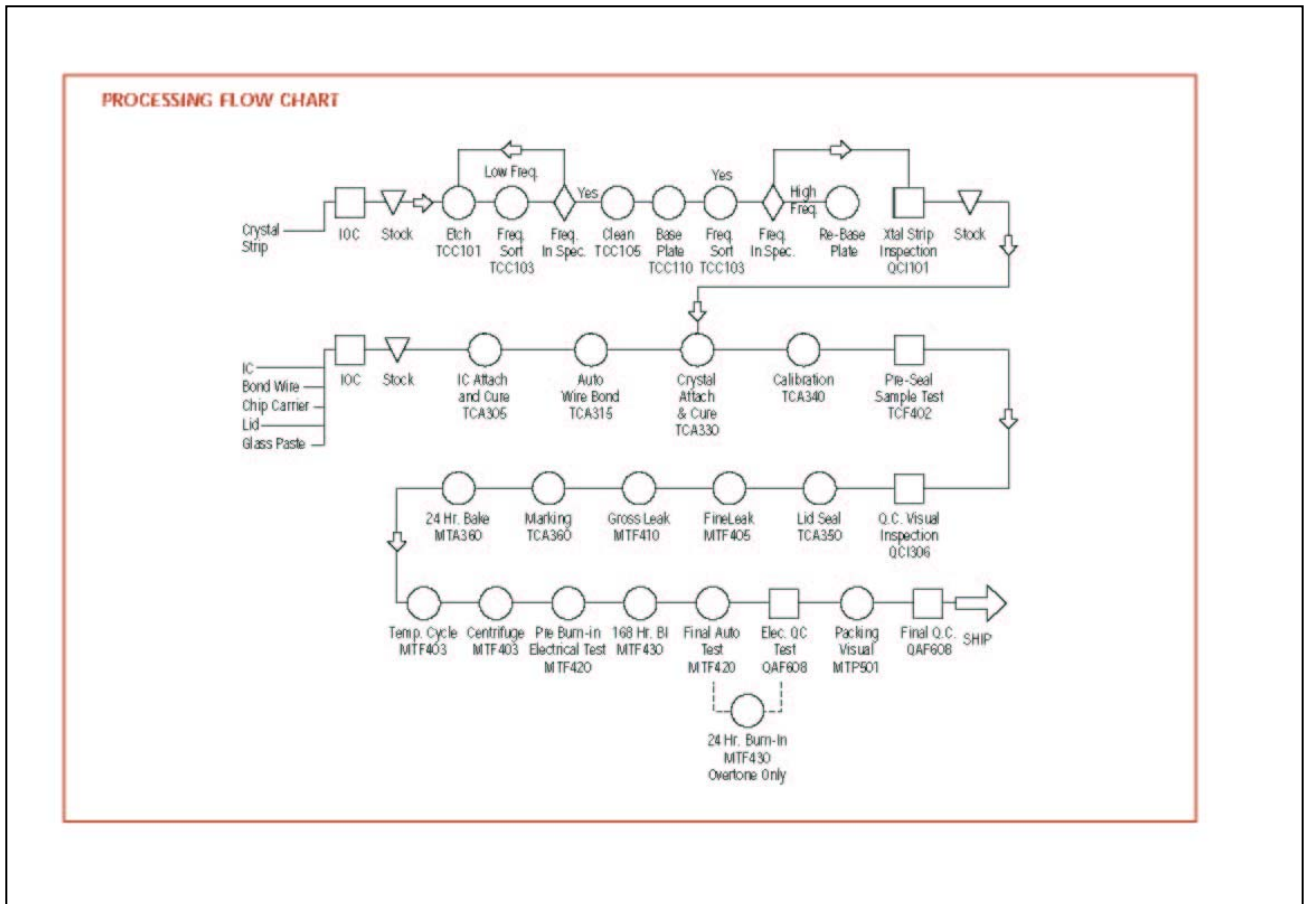
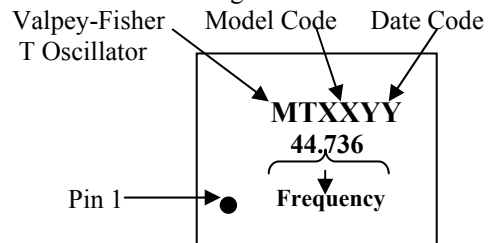

T5321, T5322, T5323, T5324
T5421, T5422, T5423, T5424
5X7 mm Surface Mount High Reliability
Fixed/Tristate, 1 MHz to 100MHz

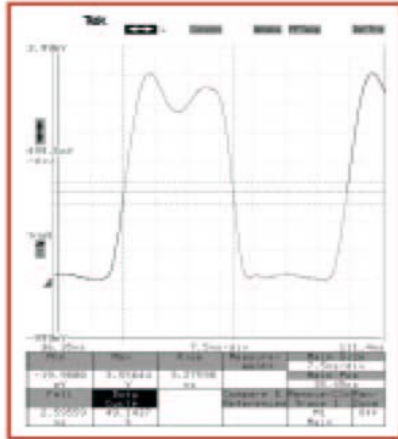
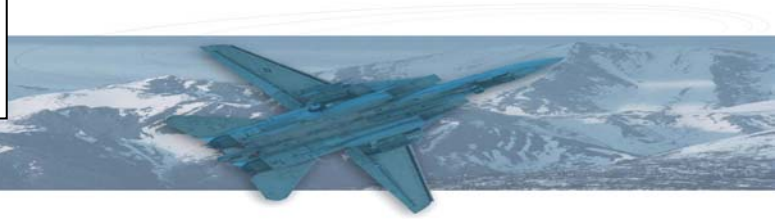

Fig.1 T5322-20M with 25pf load

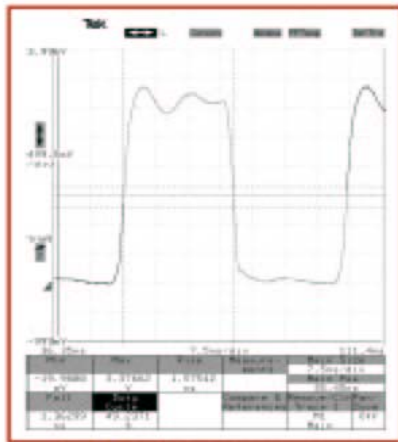

Fig. 2 T5322-20M without load

TABLE 2 — RELIABILITY TEST PROCEDURE AND CONDITIONS FOR QUARTZ CRYSTAL OSCILLATORS

I. Group A
 Electrical Characteristics at -55, 25 and 125°C
 (85°C for T5322 and T5422)
 Frequency @ 3.0, 3.3 and 3.6 volts
 Symmetry (Duty Cycle)
 Input current
 Zero/One levels
 Rise/Fall times
 Physical Dimensions
 Length/Width
 Height
 Glass seal (Visual)
 Package finish (Corrosion, discoloration, etc.)
 Marking placement/legibility

II. Group B
 1000 hrs aging at or above 125°C, 3.3V VDC, with proper load

III. Group C – All units have passed Group A testing

A. Subgroup 1 – 8 pcs.

Standard	Condition	Description	End point measurement
MIL-STD-883	METHOD 2002 COND. B	Mechanical shock 1500 g's, 0.5ms 5 blows, 6 axis	Frequency Output waveform
MIL-STD-883	METHOD 2007 COND. A	Vibration, var. freq. 20 g's, .06" disp., 20- 20,000-20 Hz	Frequency Output waveform
MIL-STD-883	METHOD 2003	Solderability	Visual 95% coverage

B. Subgroup 2 - 4 pcs. (One-half of Subgroup 1)

Standard	Condition	Description	End point measurement
MIL-STD-883	METHOD 1011 COND. B	Thermal Shock Liq. to liq. -55 to 125°C, 15 cycles	Frequency Output waveform
MIL-STD-202	METHOD 105 COND. B.	Altitude, 3.44 inch Hg, 12 hrs	Frequency Output waveform
MIL-STD-883	METHOD 1004	Moisture resist with 3.3V applied 25-65°C, 90 to 100% RH, 10 cycles	Frequency Output waveform
MIL-STD-202	METHOD 210 COND. A.	Resistance to Solder Heat Immersion @350°C 3.5 sec	Frequency Output waveform

C. Subgroup 3 - 4 pcs. (One half of Subgroup 1)

Standard	Condition	Description	End point measurement
	Storage Temp. No. Oper	24 hrs. @ -55°C 24 hrs. @ 125°C	Frequency Output waveform
MIL-STD-883	METHOD 1009 COND. A	Salt Atmosphere 24 hrs. @ 35°C .5-3.0% Solution	Frequency Output waveform Visual
MIL-STD-883	METHOD 1014 COND. A1	Fine Leak	Qs < 5 x 10 ⁻⁶
MIL-STD-883	METHOD 1014 COND. C1	Gross Leak	Visual in 125°C Detector fluid

HOW TO ORDER

For Part Number, put package type before model number, and add frequency in MHz, for example:

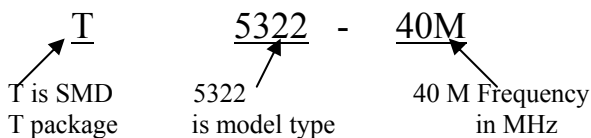

X-ON Electronics

Largest Supplier of Electrical and Electronic Components

Click to view similar products for [cts manufacturer](#):

Other Similar products are found below :

[744C083333JP](#) [407F11C012M0000](#) [0538-011-F-15.0-60](#) [Z3A-22IB-3-BNL](#) [4306-033](#) [CB3LV-3C-32M7680](#) [744C083222JP](#) [744C083102JP](#)
[770101223](#) [4400-506](#) [026TB32R253B1A1](#) [APF30-30-13CB/A01](#) [MXO45HST-3C-16M0000](#) [CB3-3I-24M0000](#) [ATS061C](#) [743C083104JP](#)
[744C083472JP](#) [77083103P](#) [218-10LPSTRF](#) [O7050147456MFDA4SC](#) [402WF20012IMR](#) [KFF6516A](#) [194-8MST](#) [742C083330JPTR](#)
[766143221GP](#) [766163470GP](#) [77061333P](#) [403C35D12M00000](#) [7609-501LF](#) [CTS-1621](#) [745C101103JP](#) [284TBCF502A26A1](#) [766163560GP](#)
[CB3-3I-20M0000](#) [4300-060LF](#) [218-4LPSTF](#) [4400-032](#) [ATS12ASM-1](#) [201XR104B](#) [770103101P](#) [209-2MSF](#) [6740-2015](#) [CB3-3C-1M5440](#)
[T8031-5V](#) [206-12ST](#) [767163104D](#) [PB1-36ND](#) [ATS049BSM-1E](#) [TX0506-1B](#) [4400-095LF](#)