

**TOSHIBA**

TOSHIBA Original CMOS 16-Bit Microcontroller

**TLCS-900 Series**

**TMP96C141BFG**

Not Recommended  
for New Design

**TOSHIBA CORPORATION**

Semiconductor Company

# Preface

Thank you very much for making use of Toshiba microcomputer LSIs.  
Before use this LSI, refer the section, "Points of Note and Restrictions".  
Especially, take care below cautions.

## **\*\*CAUTION\*\***

### How to release the HALT mode

Usually, interrupts can release all halts status. However, the interrupts = ( $\overline{NMI}$ , INT0), which can release the HALT mode may not be able to do so if they are input during the period CPU is shifting to the HALT mode (for about 3 clocks of X1) with IDLE or STOP mode. (In this case, an interrupt request is kept on hold internally.)

If another interrupt is generated after it has shifted to HALT mode completely, halt status can be released without difficulty. The priority of this interrupt is compare with that of the interrupt kept on hold internally, and the interrupt with higher priority is handled first followed by the other interrupt.

Not Recommended for New Decision

## Document Change Notification

The purpose of this notification is to inform customers about the launch of the Pb-free version of the device. The introduction of a Pb-free replacement affects the datasheet. Please understand that this notification is intended as a substitute for a revision of the datasheet.

Changes to the datasheet may include the following, though not all of them may apply to this particular device.

1. Part number

Example: TMPxxxxxF → TMPxxxxxFG

All references to the previous part number were left unchanged in body text. The new part number is indicated on the prelims pages (cover page and this notification).

2. Package code and package dimensions

Example: LQFP100-P-1414-0.50C → LQFP100-P-1414-0.50F

All references to the previous package code and package dimensions were left unchanged in body text. The new ones are indicated on the prelims pages.

3. Addition of notes on lead solderability

Now that the device is Pb-free, notes on lead solderability have been added.

4. RESTRICTIONS ON PRODUCT USE

The previous (obsolete) provision might be left unchanged on page 1 of body text. A new replacement is included on the next page.

5. Publication date of the datasheet

The publication date at the lower right corner of the prelims pages applies to the new device.

1. Part number

Previous Part Number (in Body Text)	New Part Number
TMP96C141BF	TMP96C141BFG

2. Package code and dimensions

Previous Package Code (in Body Text)	New Package Code
QFP80-P-1420-0.80	QFP80-P-1420-0.80M

\*: For the dimensions of the new package, see the attached Package Dimensions diagram.

3. Addition of notes on lead solderability

The following solderability test is conducted on the new device.

Solderability of lead free products

Test Parameter	Test Condition	Note
Solderability	Use of Sn-37Pb solder Bath Solder bath temperature = 230°C, Dipping time = 5 seconds The number of times = one, Use of R-type flux	Pass: Solderability rate until forming ≥ 95%
	Use of Sn-3.0Ag-0.5Cu solder bath Solder bath temperature = 245°C, Dipping time = 5 seconds The number of times = one, Use of R-type flux (use of lead free)	

4. RESTRICTIONS ON PRODUCT USE

The following replaces the “RESTRICTIONS ON PRODUCT USE” on page 1 of body text.

**RESTRICTIONS ON PRODUCT USE**

20070701-EN

<ul style="list-style-type: none"> <li>The information contained herein is subject to change without notice.</li> <li>TOSHIBA is continually working to improve the quality and reliability of its products. Nevertheless, semiconductor devices in general can malfunction or fail due to their inherent electrical sensitivity and vulnerability to physical stress. It is the responsibility of the buyer, when utilizing TOSHIBA products, to comply with the standards of safety in making a safe design for the entire system, and to avoid situations in which a malfunction or failure of such TOSHIBA products could cause loss of human life, bodily injury or damage to property. In developing your designs, please ensure that TOSHIBA products are used within specified operating ranges as set forth in the most recent TOSHIBA products specifications. Also, please keep in mind the precautions and conditions set forth in the "Handling Guide for Semiconductor Devices," or "TOSHIBA Semiconductor Reliability Handbook" etc.</li> <li>The TOSHIBA products listed in this document are intended for usage in general electronics applications (computer, personal equipment, office equipment, measuring equipment, industrial robotics, domestic appliances, etc.). These TOSHIBA products are neither intended nor warranted for usage in equipment that requires extraordinarily high quality and/or reliability or a malfunction or failure of which may cause loss of human life or bodily injury ("Unintended Usage"). Unintended Usage include atomic energy control instruments, airplane or spaceship instruments, transportation instruments, traffic signal instruments, combustion control instruments, medical instruments, all types of safety devices, etc.. Unintended Usage of TOSHIBA products listed in his document shall be made at the customer's own risk.</li> <li>The products described in this document shall not be used or embedded to any downstream products of which manufacture, use and/or sale are prohibited under any applicable laws and regulations.</li> <li>The information contained herein is presented only as a guide for the applications of our products. No responsibility is assumed by TOSHIBA for any infringements of patents or other rights of the third parties which may result from its use. No license is granted by implication or otherwise under any patents or other rights of TOSHIBA or the third parties.</li> <li>Please contact your sales representative for product-by-product details in this document regarding RoHS compatibility. Please use these products in this document in compliance with all applicable laws and regulations that regulate the inclusion or use of controlled substances. Toshiba assumes no liability for damage or losses occurring as a result of noncompliance with applicable laws and regulations.</li> <li>For a discussion of how the reliability of microcontrollers can be predicted, please refer to Section 1.3 of the chapter entitled Quality and Reliability Assurance/Handling Precautions.</li> </ul>
---

5. Publication date of the datasheet

The publication date of this datasheet is printed at the lower right corner of this notification.



(Annex)

Package Dimensions

QFP80-P-1420-0.80M

Unit: mm

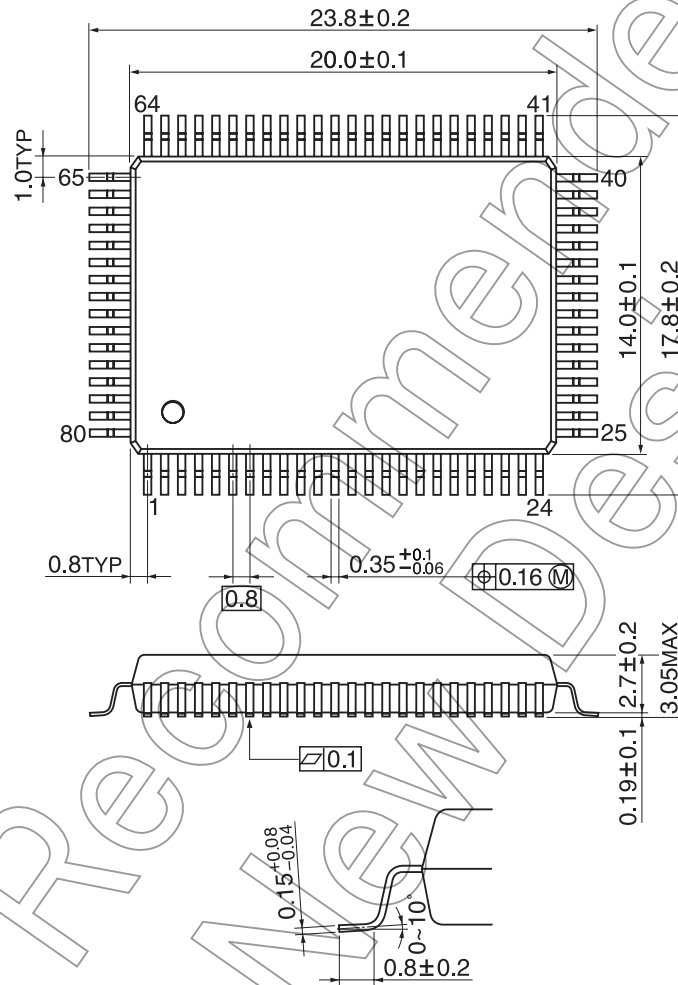

Not Recommended for New Design

## CMOS 16-bit Microcontrollers

## TMP96C141BF

## 1. Outline and Device Characteristics

TMP96C141BF is high-speed advanced 16-bit microcontrollers developed for controlling medium to large-scale equipment.

TMP96C141BF is housed in an 80-pin flat package.

Device characteristics are as follows:

- (1) Original 16-bit CPU
  - TLCS-90 instruction mnemonic upward compatible.
  - 16M-byte linear address space
  - General-purpose registers and register bank system
  - 16-bit multiplication / division and bit transfer/arithmetic instructions
  - High-speed micro DMA : 4 channels (1.6  $\mu$ s/2 bytes @ 20 MHz)
- (2) Minimum instruction execution time : 200 ns @ 20 MHz
- (3) Internal RAM : 1 Kbyte  
Internal ROM : None
- (4) External memory expansion
  - Can be expanded up to 16M bytes (for both programs and data).
  - Can mix 8- and 16-bit external data buses.
- (5) 8-bit timers : 2 channels
- (6) 8-bit PWM timers : 2 channels
- (7) 16-bit timers : 2 channels
- (8) Pattern generators : 4 bits, 2 channels
- (9) Serial interface : 2 channels
- (10) 10-bit A/D converter : 4 channels
- (11) Watchdog timer
- (12) Chip select/wait controller : 3 blocks
- (13) Interrupt functions
  - 3 CPU interrupts : SWI instruction, privileged violation, and Illegal instruction
  - 14 internal interrupts
  - 6 external interrupts } 7-level priority can be set.
- (14) I/O ports
- (15) Standby function : 3 halt modes (RUN, IDLE, STOP)

000707EBP1

- For a discussion of how the reliability of microcontrollers can be predicted, please refer to Section 1.3 of the chapter entitled Quality and Reliability Assurance / Handling Precautions.
- TOSHIBA is continually working to improve the quality and reliability of its products. Nevertheless, semiconductor devices in general can malfunction or fail due to their inherent electrical sensitivity and vulnerability to physical stress. It is the responsibility of the buyer, when utilizing TOSHIBA products, to comply with the standards of safety in making a safe design for the entire system, and to avoid situations in which a malfunction or failure of such TOSHIBA products could cause loss of human life, bodily injury or damage to property.  
In developing your designs, please ensure that TOSHIBA products are used within specified operating ranges as set forth in the most recent TOSHIBA products specifications. Also, please keep in mind the precautions and conditions set forth in the "Handling Guide for Semiconductor Devices," or "TOSHIBA Semiconductor Reliability Handbook" etc..
- The TOSHIBA products listed in this document are intended for usage in general electronics applications (computer, personal equipment, office equipment, measuring equipment, industrial robotics, domestic appliances, etc.). These TOSHIBA products are neither intended nor warranted for usage in equipment that requires extraordinarily high quality and/or reliability or a malfunction or failure of which may cause loss of human life or bodily injury ("Unintended Usage"). Unintended Usage include atomic energy control instruments, airplane or spaceship instruments, transportation instruments, traffic signal instruments, combustion control instruments, medical instruments, all types of safety devices, etc.. Unintended Usage of TOSHIBA products listed in this document shall be made at the customer's own risk.
- The products described in this document are subject to the foreign exchange and foreign trade laws.
- The information contained herein is presented only as a guide for the applications of our products. No responsibility is assumed by TOSHIBA CORPORATION for any infringements of intellectual property or other rights of the third parties which may result from its use. No license is granted by implication or otherwise under any intellectual property or other rights of TOSHIBA CORPORATION or others.
- The information contained herein is subject to change without notice.

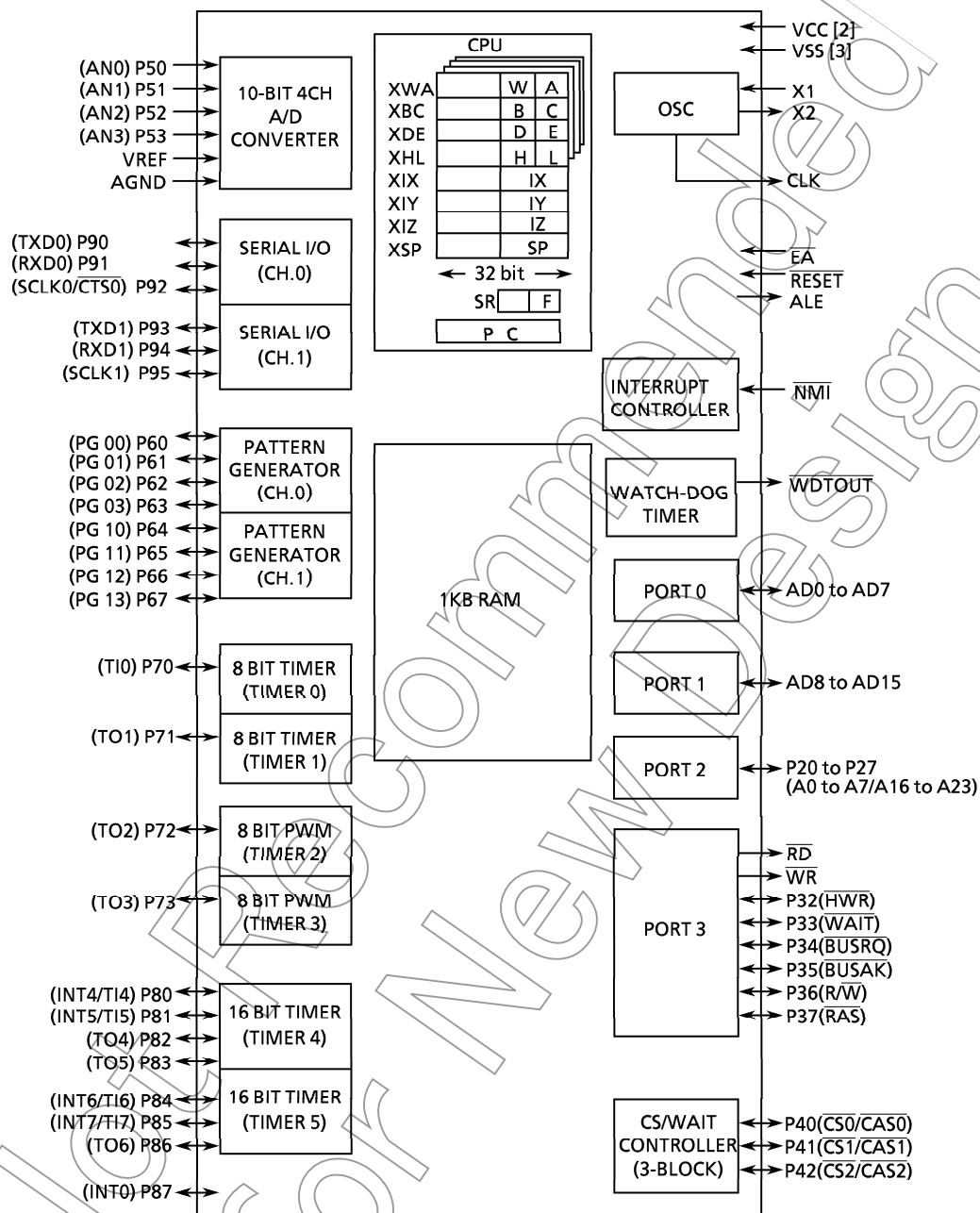

Figure1 TMP96C141BF Block Diagram

## 2. Pin Assignment and Functions

The assignment of input / output pins for TMP96C141BF, their name and outline functions are described below.

### 2.1 Pin Assignment

Figure 2.1 shows pin assignment of TMP96C141BF.

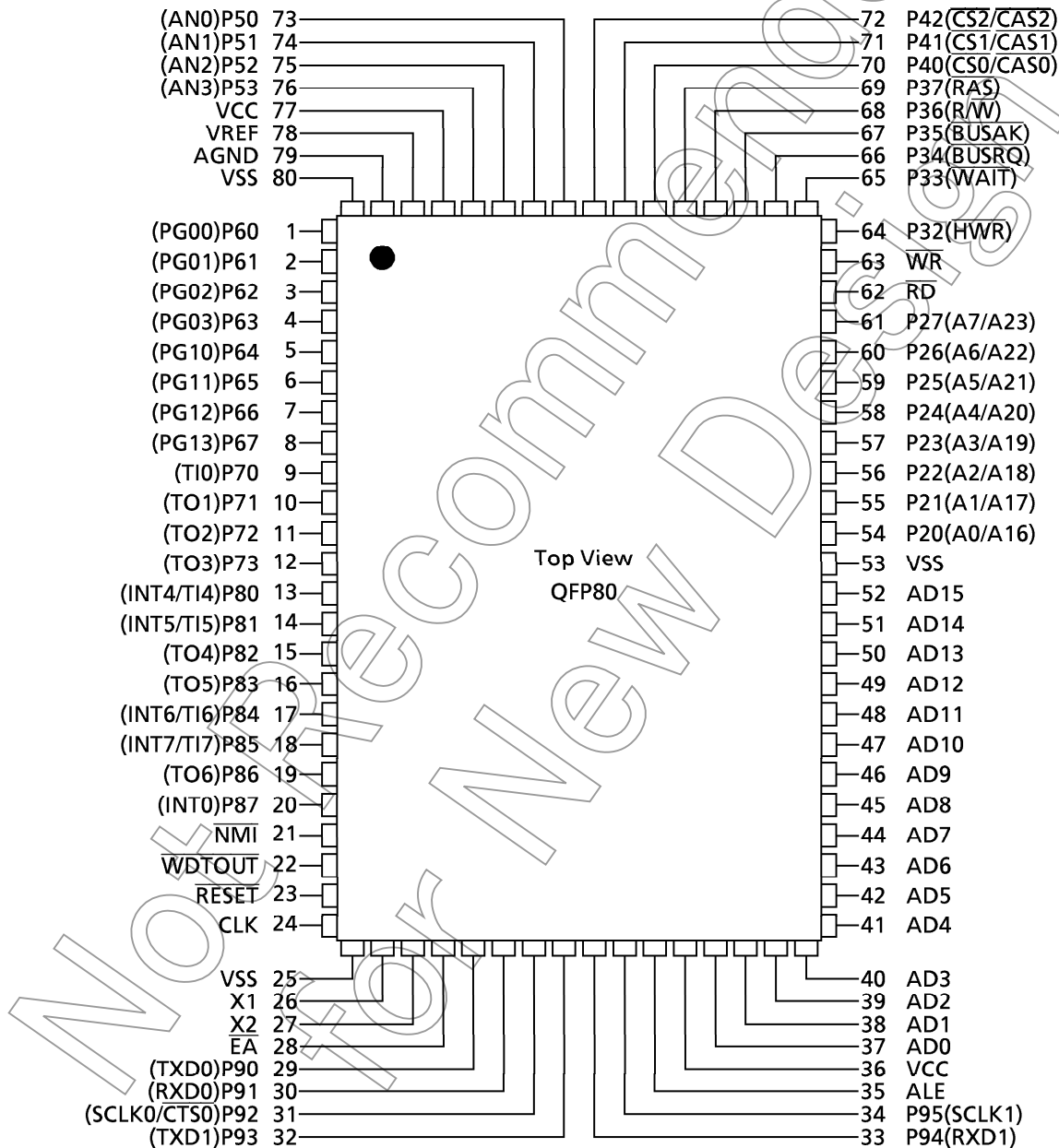

Figure 2.1 Pin Assignment (80-pin QFP)

## 2.2 Pin Names and Functions

The names of input/output pins and their functions are described below.

Table 2.2 Pin Names and Functions.

Pin name	Number of pins	I/O	Functions
AD0 to AD7	8	Tri-state	Address/data (lower): 0 to 7 for address/data bus
AD8 to AD15	8	Tri-state	Address data (upper): 8 to 15 for address/data bus
P20 to P27	8	I/O	Port 2: I/O port that allows selection of I/O on a bit basis (with pull-down resistor)
A0 to A7		Output	Address: 0 to 7 for address bus
A16 to A23		Output	Address: 16 to 23 for address bus
$\overline{RD}$	1	Output	Read: Strobe signal for reading external memory
$\overline{WR}$	1	Output	Write: Strobe signal for writing data on pins AD0 to 7
P32	1	I/O	Port 32: I/O port (with pull-up resistor)
$\overline{HWR}$		Output	High write: Strobe signal for writing data on pins AD8 to 15
P33	1	I/O	Port 33: I/O port (with pull-up resistor)
$\overline{WAIT}$		Input	Wait: Pin used to request CPU bus wait
P34	1	I/O	Port 34: I/O port (with pull-up resistor)
$\overline{BUSRQ}$		Input	Bus request: Signal used to request high impedance for AD0 to 15, A0 to 23, $\overline{RD}$ , $\overline{WR}$ , $\overline{HWR}$ , $\overline{R/W}$ , $\overline{RAS}$ , $\overline{CS0}$ , $\overline{CS1}$ , and $\overline{CS2}$ pins. (For external DMAC)
P35	1	I/O	Port 35: I/O port (with pull-up resistor)
$\overline{BUSAK}$		Output	Bus acknowledge: Signal indicating that AD0 to 15, A0 to 23, $\overline{RD}$ , $\overline{WR}$ , $\overline{HWR}$ , $\overline{R/W}$ , $\overline{RAS}$ , $\overline{CS0}$ , $\overline{CS1}$ , and $\overline{CS2}$ pins are at high impedance after receiving $\overline{BUSRQ}$ . (For external DMAC)
P36	1	I/O	Port 36: I/O port (with pull-up resistor)
$\overline{R/W}$		Output	Read/write: 1 represents read or dummy cycle; 0, write cycle.
P37	1	I/O	Port 37: I/O port (with pull-up resistor)
$\overline{RAS}$		Output	Row address strobe: Outputs RAS strobe for DRAM.
P40	1	I/O	Port 40: I/O port (with pull-up resistor)
$\overline{CS0}$		Output	Chip select 0: Outputs 0 when address is within specified address area.
$\overline{CAS0}$		Output	Column address strobe 0: Outputs CAS strobe for DRAM when address is within specified address area.

Note: With the external DMA controller, this device's built-in memory or built-in I/O cannot be accessed using the  $\overline{BUSRQ}$  and  $\overline{BUSAK}$  pins.

Pin name	Number of pins	I/O	Functions
P41 CS1 CAS1	1	I/O Output Output	Port 41: I/O port (with pull-up resistor) Chip select 1: Outputs 0 if address is within specified address area. Column address strobe 1: Outputs CAS strobe for DRAM if address is within specified address area.
P42 CS2 CAS2	1	I/O Output Output	Port 42: I/O port (with pull-down resistor) (Note) Chip select 2: Outputs 0 if address is within specified address area. Column address strobe 2: Outputs CAS strobe for DRAM if address is within specified address area.
P50 to P53 AN0 to AN3	4	Input Input	Port 5: Input port Analog input: Input to A/D converter
VREF	1	Input	Pin for reference voltage input to A/D converter
AGND	1	Input	Ground pin for A/D converter
P60 to P63 PG00 to PG03	4	I/O Output	Ports 60 to 63: I/O ports that allow selection of I/O on a bit basis (with pull-up resistor) Pattern generator ports: 00 to 03
P64 to P67 PG10 to PG13	4	I/O Output	Ports 64 to 67: I/O ports that allow selection of I/O on a bit basis (with pull-up resistor) Pattern generator ports: 10 to 13
P70 TI0	1	I/O Input	Port 70: I/O port (with pull-up resistor) Timer input 0: Timer 0 input
P71 TO1	1	I/O Output	Port 71: I/O port (with pull-up resistor) Timer output 1: Timer 0 or 1 output
P72 TO2	1	I/O Output	Port 72: I/O port (with pull-up resistor) PWM output 2: 8-bit PWM timer 2 output
P73 TO3	1	I/O Output	Port 73: I/O port (with pull-up resistor) PWM output 3: 8-bit PWM timer 3 output
P80 TI4 INT4	1	I/O Input Input	Port 80: I/O port (with pull-up resistor) Timer input 4: Timer 4 count/capture trigger signal input Interrupt request pin 4: Interrupt request pin with programmable rising/falling edge
P81 TI5 INT5	1	I/O Input Input	Port 81: I/O port (with pull-up resistor) Timer input 5: Timer 4 count/capture trigger signal input Interrupt request pin 5: Interrupt request pin with rising edge
P82 TO4	1	I/O Output	Port 82: I/O port (with pull-up resistor) Timer output 4: Timer 4 output pin
P83 TO5	1	I/O Output	Port 83: I/O port (with pull-up resistor) Timer output 5: Timer 4 output pin

Note : Case of the settable  $\overline{CS2}$  or  $\overline{CAS2}$  ; when TMP96C141BF is bus release, this pin is not added the internal pull-down resistor but is added the internal pull-up resistor.

Pin name	Number of pins	I/O	Functions
P84 TI6 INT6	1	I/O Input Input	Port 84: I/O port (with pull-up resistor) Timer input 6: Timer 5 count/capture trigger signal input Interrupt request pin 6: Interrupt request pin with programmable rising/falling edge
P85 TI7 INT7	1	I/O Input Input	Port 85: I/O port (with pull-up resistor) Timer input 7: Timer 5 count/capture trigger signal input Interrupt request pin 7: Interrupt request pin with rising edge
P86 TO6	1	I/O Output	Port 86: I/O port (with pull-up resistor) Timer output 6: Timer 5 output pin
P87 INT0	1	I/O Input	Port 87: I/O port (with pull-up resistor) Interrupt request pin 0: Interrupt request pin with programmable level/rising edge
P90 TXD0	1	I/O Output	Port 90: I/O port (with pull-up resistor) Serial send data 0
P91 RXD0	1	I/O Input	Port 91: I/O port (with pull-up resistor) Serial receive data 0
P92 CTS0	1	I/O Input	Port 92: I/O port (with pull-up resistor) Serial data send enable 0 (Clear to Send)
P93 TXD1	1	I/O Output	Port 93: I/O port (with pull-up resistor) Serial send data 1
P94 RXD1	1	I/O Input	Port 94: I/O port (with pull-up resistor) Serial receive data 1
P95 SCLK1	1	I/O I/O	Port 95: I/O port (with pull-up resistor) Serial clock I/O 1
WDTOUT	1	Output	Watchdog timer output pin
NMI	1	Input	Non-maskable interrupt request pin: Interrupt request pin with falling edge. Can also be operated at rising edge by program.
CLK	1	Output	Clock output: Outputs $\lceil X1 \div 4 \rceil$ clock. Pulled-up during reset.
$\overline{EA}$	1	Input	External access: 0 should be inputted with TMP96C141B
ALE	1	Output	Address latch enable
$\overline{RESET}$	1	Input	Reset: Initializes LSI. (With pull-up resistor)
X1/X2	2	I/O	Oscillator connecting pin
VCC	2		Power supply pin (+5V) (All Vcc pins should be connected with the power supply pin.)
VSS	3		GND pin (0V) (All Vss pins should be connected with GND (0V).)

Note: Pull-up/pull-down resistor can be released from the pin by software (except the  $\overline{RESET}$  pin).

### 3. Operation

This section describes in blocks the functions and basic operations of TMP96C141BF device.

Check the [ 7. Care Points and Restriction ] because of the Care Points etc are described.

#### 3.1 CPU

TMP96C141BF device has a built-in high-performance 16-bit CPU (900-CPU). (For CPU operation, see TLCS-900 CPU in the previous section.)

This section describes CPU functions unique to TMP96C141BF that are not described in the previous section.

##### 3.1.1 Reset

To reset the TMP96C141BF, the **RESET** input must be kept at 0 for at least 10 system clocks (10 states: 1  $\mu$ s with a 20 MHz system clock) within an operating voltage range and with a stable oscillation.

When reset is accepted, the CPU sets as follows:

- Program counter (PC) to 8000H.
- Stack pointer (XSP) for system mode to 100H.
- SYSM bit of status register (SR) to 1. (Sets to system mode.)
- IFF2 to 0 bits of status register to 111. (Sets mask register to interrupt level 7.)
- MAX bit of status register to 0. (Sets to minimum mode)
- Bits RFP2 to 0 of status register to 000. (Sets register banks to 0.)

When reset is released, instruction execution starts from address 8000H. CPU internal registers other than the above are not changed.

When reset is accepted, processing for built-in I/Os, ports, and other pins is as follows

- Initializes built-in I/O registers as per specifications.
- Sets port pins (including pins also used as built-in I/Os) to general-purpose input/output port mode (sets I/O ports to input ports).
- Sets the **WDTOUT** pin to 0. (Watchdog timer is set to enable after reset.)
- Pulls up the **CLK** pin to 1.
- Sets the **ALE** pin to 0.



3.2 Memory Map

Figure 3.2 is a memory map of the TMP96C141B.

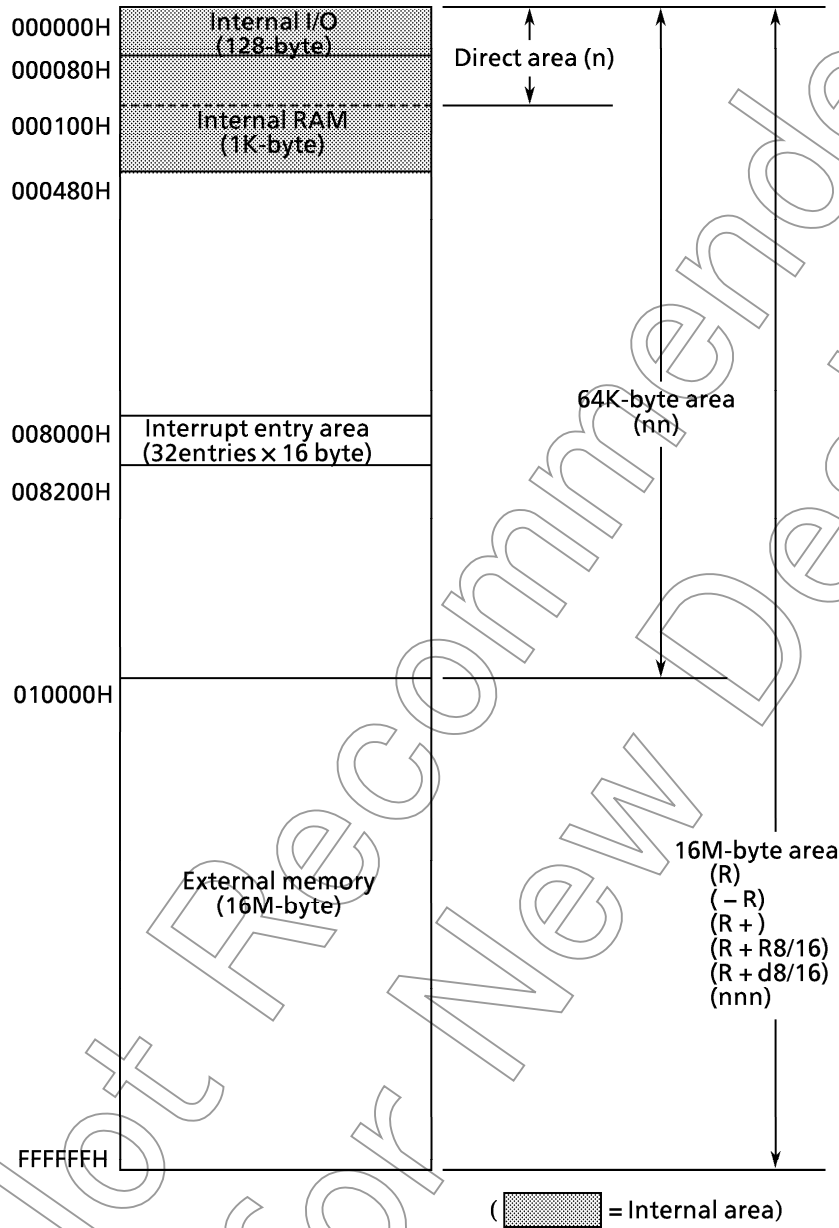

Note: The start address after reset is 8000H. Resetting sets the stack pointer (XSP) on the system mode side to 100H.

Figure3.2 Memory map

### 3.3 Interrupts

TLCS-900 interrupts are controlled by the CPU interrupt mask flip-flop (IFF2 to 0) and the built-in interrupt controller.

TMP96C141B has altogether the following 23 interrupt sources:

- Interrupts from the CPU... 3  
(Software interrupts, privileged violations, and Illegal (undefined) instruction execution)
- Interrupts from external pins (NMI, INT0, and INT4 to 7)... 6
- Interrupts from built-in I/Os... 14

A fixed individual interrupt vector number is assigned to each interrupt source; six levels of priority (variable) can also be assigned to each maskable interrupt. Non-maskable interrupts have a fixed priority of 7.

When an interrupt is generated, the interrupt controller sends the value of the priority of the interrupt source to the CPU. When more than one interrupt is generated simultaneously, the interrupt controller sends the value of the highest priority (7 for non-maskable interrupts is the highest) to the CPU.

The CPU compares the value of the priority sent with the value in the CPU interrupt mask register (IFF2 to 0). If the value is greater than that the CPU interrupt mask register, the interrupt is accepted. The value in the CPU interrupt mask register (IFF2 to 0) can be changed using the EI instruction (contents of the EI num/IFF<2:0> = num). For example, programming EI 3 enables acceptance of maskable interrupts with a priority of 3 or greater, and non-maskable interrupts which are set in the interrupt controller. The DI instruction (IFF<2:0> = 7) operates in the same way as the EI 7 instruction. Since the priority values for maskable interrupts are 0 to 6, the DI instruction is used to disable maskable interrupts to be accepted. The EI instruction becomes effective immediately after execution. (With the TLCS-90, the EI instruction becomes effective after execution of the subsequent instruction.)

In addition to the general-purpose interrupt processing mode described above, there is also a high-speed micro-DMA processing mode. High-speed micro-DMA is a mode used by the CPU to automatically transfer byte or word data. It enables the CPU to process interrupts such as data saves to built-in I/Os at high speed.

Figure 3.3 (1) is a flowchart showing overall interrupt processing.

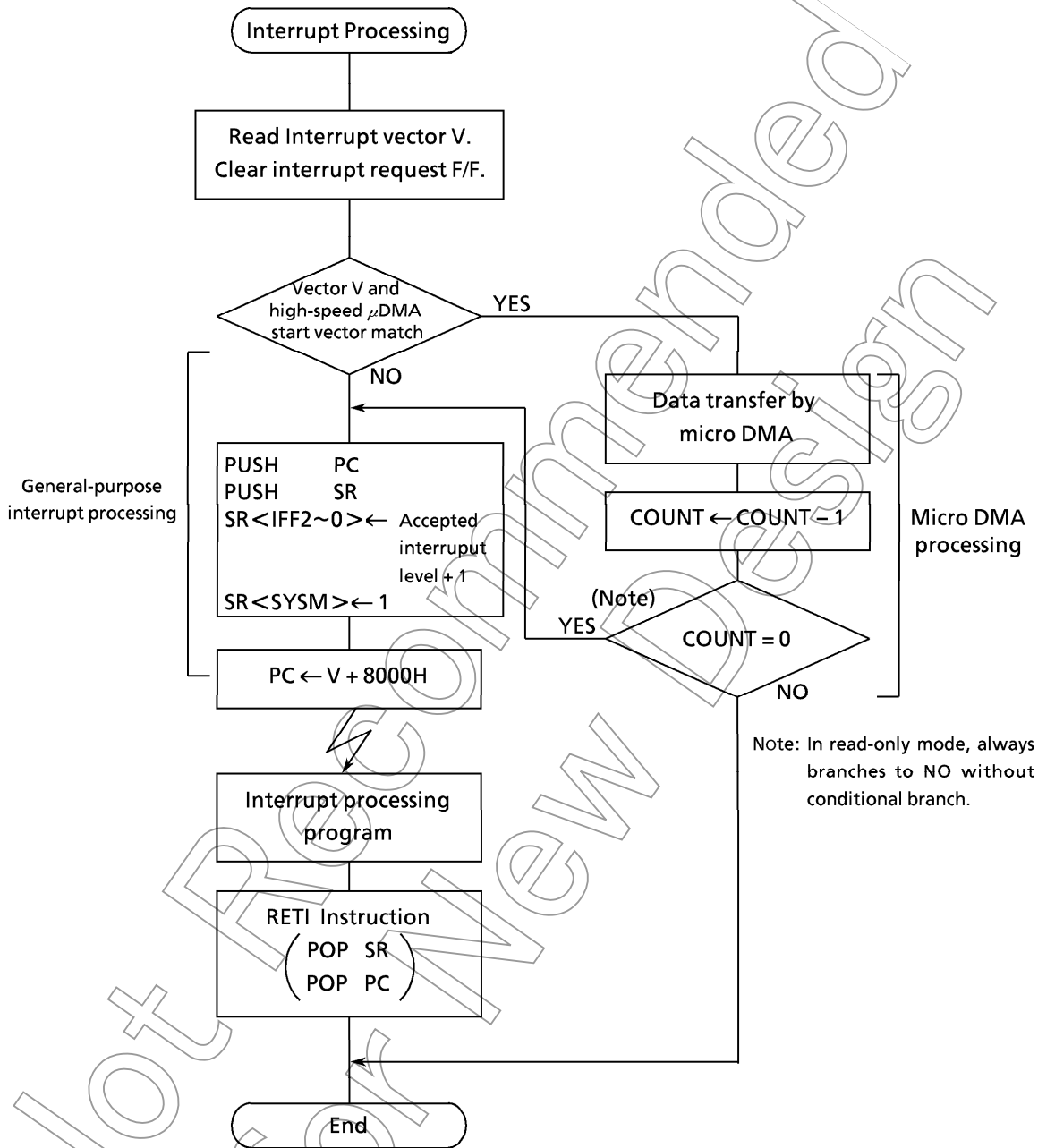

Figure3.3 (1) Interrupt Processing Flowchart

310189

### 3.3.1 General-Purpose Interrupt Processing

When accepting an interrupt, the CPU operates as follows:

- (1) The CPU reads the interrupt vector from the interrupt controller. When more than one interrupt with the same level is generated simultaneously, the interrupt controller generates interrupt vectors in accordance with the default priority (which is fixed as follows: the smaller the vector value, the higher the priority), then clears the interrupt request.
- (2) The CPU pushes the program counter and the status register to the system stack area (area indicated by the system mode stack pointer).
- (3) The CPU sets a value in the CPU interrupt mask register <IFF2 to 0> that is higher by 1 than the value of the accepted interrupt level. However, if the value is 7, 7 is set without an increment.
- (4) The CPU sets the <SYSM> flag of the status register to 1 and enter the system mode.
- (5) The CPU jumps to address 8000H + interrupt vector, then starts the interrupt processing routine.

In minimum mode, all the above processing is completed in 15 states (1.5  $\mu$ s @20 MHz). In maximum mode, it is completed in 17 states.

Bus Width of stack Area	Interrupt processing state number	
	MAX mode	MIN mode
8 bit	23	19
16 bit	17	15

To return to the main routine after completion of the interrupt processing, the RETI instruction is usually used. Executing this instruction restores the contents of the program counter and the status registers.

Though acceptance of non-maskable interrupts cannot be disabled by program, acceptance of maskable interrupts can. A priority can be set for each source of maskable interrupts. The CPU accepts an interrupt request with a priority higher than the value in the CPU mask register <IFF2 to 0>. The CPU mask register <IFF2 to 0> is set to a value higher by 1 than the priority of the accepted interrupt. Thus, if an interrupt with a level higher than the interrupt being processed is generated, the CPU accepts the interrupt with the higher level, causing interrupt processing to nest. The interrupt request with a priority higher than the accepted now interrupt during the CPU is processing above (1) to (5) is accepted before the 1'st instruction in the interrupt processing routine, causing interrupt processing to nest. (This is the same case of overlapped each Non-Maskable interrupt (level "7").) The CPU does not accept an interrupt

request of the same level as that of the interrupt being processed. The CPU does not accept an interrupt request of the same level as that of the interrupt being processed.

Resetting initializes the CPU mask registers <IFF2 to 0> to 7; therefore, maskable interrupts are disabled.

The addresses 008000H to 0081FFH (512 bytes) of the TLCS-900 are assigned for interrupt processing entry area.

Table3.3 (1) TMP96C141BF Interrupt Table

Default priority	Type	Interrupt source	Vector value "V"	Start address	High-speed micro DMA start vector
1		Reset, or SWI0 instruction	0 0 0 0 H	8 0 0 0 H	-
2		INTPREV : Privileged violation, or SWI1	0 0 1 0 H	8 0 1 0 H	-
3		INTUNDEF: Illegal instruction, or SWI2	0 0 2 0 H	8 0 2 0 H	-
4	Non-maskable	SWI 3 instruction	0 0 3 0 H	8 0 3 0 H	-
5		SWI 4 instruction	0 0 4 0 H	8 0 4 0 H	-
6		SWI 5 instruction	0 0 5 0 H	8 0 5 0 H	-
7		SWI 6 instruction	0 0 6 0 H	8 0 6 0 H	-
8		SWI 7 instruction	0 0 7 0 H	8 0 7 0 H	-
9		NMI Pin	0 0 8 0 H	8 0 8 0 H	08H
10		INTWD : Watchdog timer	0 0 9 0 H	8 0 9 0 H	09H
11	Maskable	INT0 pin	0 0 A 0 H	8 0 A 0 H	0AH
12		INT4 pin	0 0 B 0 H	8 0 B 0 H	0BH
13		INT5 pin	0 0 C 0 H	8 0 C 0 H	0CH
14		INT6 pin	0 0 D 0 H	8 0 D 0 H	0DH
15		INT7 pin	0 0 E 0 H	8 0 E 0 H	0EH
-		(Reserved)	0 0 F 0 H	8 0 F 0 H	0FH
16		INTT0 : 8-bit timer0	0 1 0 0 H	8 1 0 0 H	10H
17		INTT1 : 8-bit timer1	0 1 1 0 H	8 1 1 0 H	11H
18		INTT2 : 8-bit timer2/PWM0	0 1 2 0 H	8 1 2 0 H	12H
19		INTT3 : 8-bit timer3/PWM1	0 1 3 0 H	8 1 3 0 H	13H
20		INTTR4 : 16-bit timer4 (TREG4)	0 1 4 0 H	8 1 4 0 H	14H
21		INTTR5 : 16-bit timer4 (TREG5)	0 1 5 0 H	8 1 5 0 H	15H
22		INTTR6 : 16-bit timer5 (TREG6)	0 1 6 0 H	8 1 6 0 H	16H
23		INTTR7 : 16-bit timer5 (TREG7)	0 1 7 0 H	8 1 7 0 H	17H
24		INTRX0 : Serial receive (Channel.0)	0 1 8 0 H	8 1 8 0 H	18H
25		INTTX0 : Serial send (Channel.0)	0 1 9 0 H	8 1 9 0 H	19H
26		INTRX1 : Serial receive (Channel.1)	0 1 A 0 H	8 1 A 0 H	1AH
27		INTTX1 : Serial send (Channel.1)	0 1 B 0 H	8 1 B 0 H	1BH
28		INTAD : A/D conversion completion	0 1 C 0 H	8 1 C 0 H	1CH
-		(Reserved)	0 1 D 0 H	8 1 D 0 H	1DH
-	(Reserved)	0 1 E 0 H	8 1 E 0 H	1EH	
-	(Reserved)	0 1 F 0 H	8 1 F 0 H	1FH	

### 3.3.2 High-speed Micro DMA

In addition to the conventional interrupt processing, the TLCS-900 also has a high-speed micro DMA function. When an interrupt is accepted, in addition to an interrupt vector, the CPU receives data indicating whether processing is high-speed micro DMA mode or general-purpose interrupt. If high-speed micro DMA mode is requested, the CPU performs high-speed micro DMA processing.

The TLCS-900 can process at very high speed compared with the TLCS-90 micro DMA because it has transfer parameters in dedicated registers in the CPU. Since those dedicated registers are assigned as CPU control registers, they can only be accessed by the LDC (privileged) instruction.

#### (1) High-speed micro DMA operation

High-speed micro DMA operation starts when the accepted interrupt vector value matches the high-speed micro DMA start vector value set in the interrupt controller. The high-speed micro DMA has four channels so that it can be set for up to four types of interrupt source.

When a high-speed micro DMA interrupt is accepted, data is automatically transferred from the transfer source address to the transfer destination address set in the control register, and the transfer counter is decremented. If the value in the counter after decrementing is other than 0, high-speed micro DMA processing is completed; if the value in the counter after decrementing is 0, general-purpose interrupt processing is performed. In read-only mode, which is provided for DRAM refresh, the value in the counter is ignored and dummy read is repeated.

32-bit control registers are used for setting transfer source/destination addresses. However, the TLCS-900 has only 24 address for output. A 16M-byte space is available for the high-speed micro DMA.

There are two data transfer modes: one-byte mode and one-word mode. Incrementing, decrementing, and fixing the transfer source/destination address after transfer can be done in both modes. Therefore data can easily be transferred between I/O and memory and between I/Os. For details of transfer modes, see the description of transfer mode registers.

The transfer counter has 16 bits, so up to 65536 transfers (the maximum when the initial value of the transfer counter is 0000H) can be performed for one interrupt source by high-speed micro DMA processing.

After the data transferred by the  $\mu$ DMA function, the transfer counter was decreased.

When this counter is "0"H, the processor operates general interrupt processing. At this time, if the same channel of interrupt is required next interrupt, the transfer counter starts from 65536.

Interrupt sources processed by high-speed micro DMA processing are those with the high-speed micro DMA start vectors listed in Table 3.3 (1).

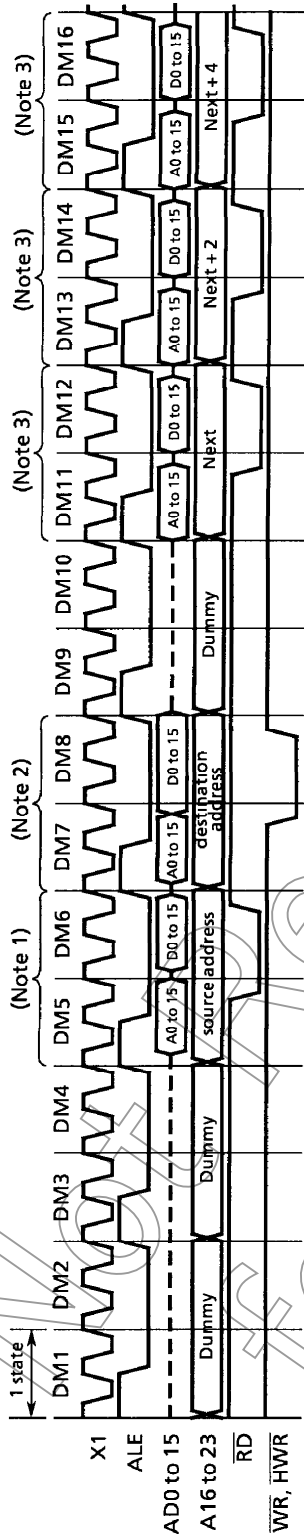

High-Speed  $\mu$ DMA cycle (COUNT  $\neq$  0)

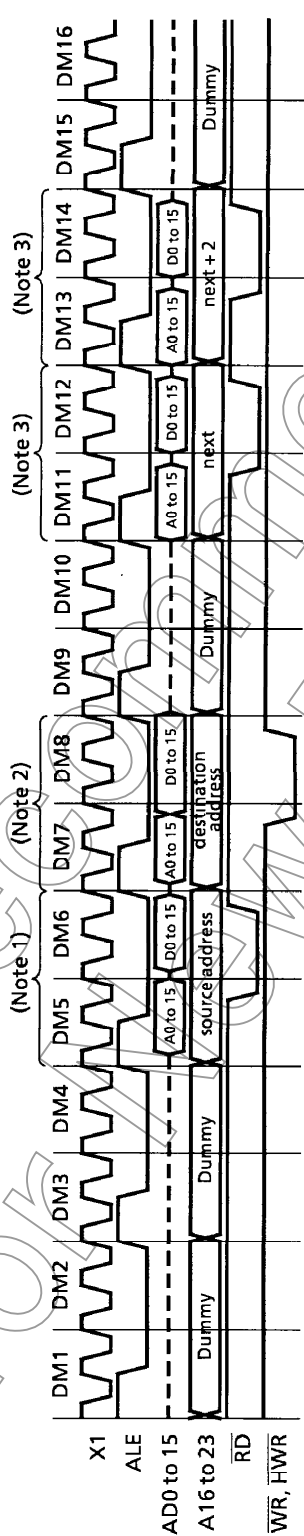

High-Speed  $\mu$ DMA cycle (COUNT = 0)

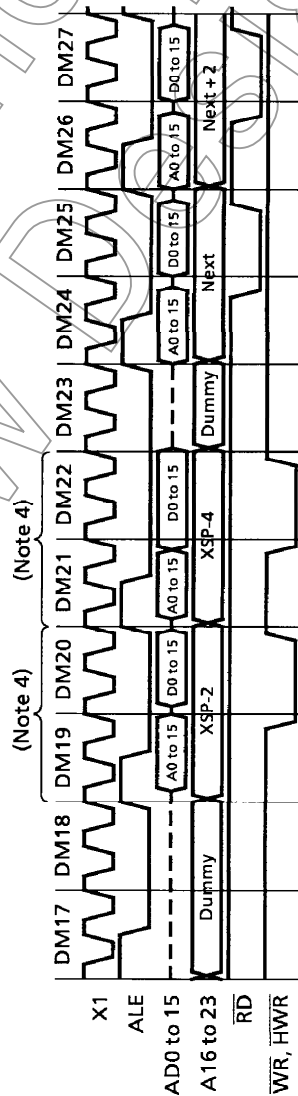

- Note 1: This is added 2 states the case of the bus width of source address area is 8bit
- Note 2: This is added 2 states the case of the bus width of destination address area is 8bit
- Note 3: This may be a dummy cycle with instruction queue buffer.
- Note 4: This is added 2 states the case of the bus width of stack address area is 8bit

The following timing chart is a high-speed  $\mu$ DMA cycle of the Transfer Address Increment mode (the other mode except the Read-only mode is same as this)

(Condition : MIN mode, 16bit Bus width for 16M Byte, 0 wait)

(2) Register configuration (CPU control register)

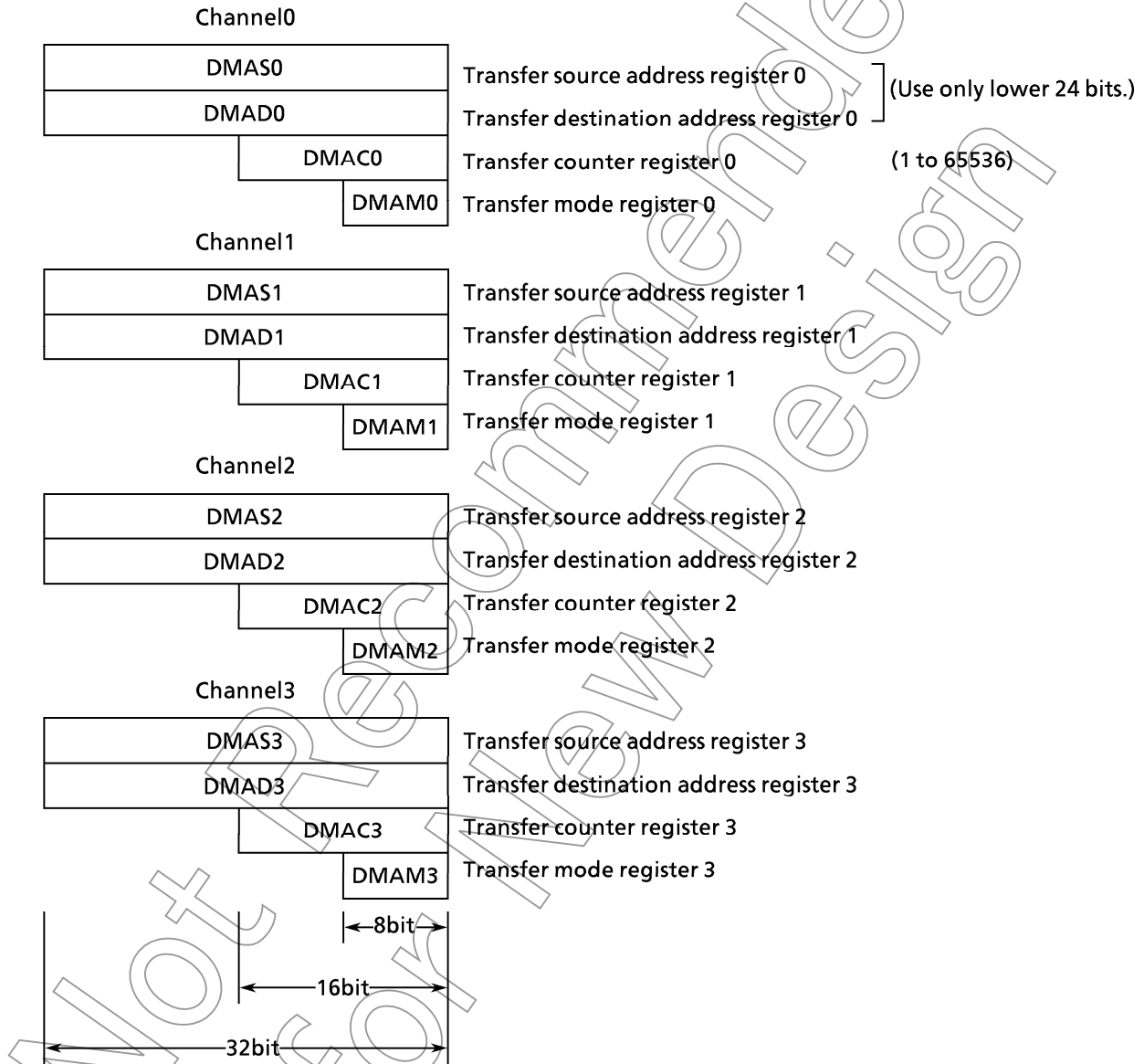

These Control Register can not be set only "LCD cr, r" instruction.



(3) Transfer mode register details

(DMAM0 to 3)

0 0 0 0	Mode	Note : When specifying values for this register, set the upper 4 bits to 0.
Z: 0 = byte transfer, 1 = word transfer		

execution time (Min.) @20MHz

0 0 0 Z	Transfer destination address INC mode ..... for I/O to memory (DMADn +) ← (DMASn) DMACn ← DMACn - 1 if DMACn = 0 then INT.	16 states (1.6 μs)
0 0 1 Z	Transfer destination address DEC mode ..... for I/O to memory (DMADn -) ← (DMASn) DMACn ← DMACn - 1 if DMACn = 0 then INT.	16 states (1.6 μs)
0 1 0 Z	Transfer source address INC mode ..... for I/O to memory (DMADn) ← (DMASn +) DMACn ← DMACn - 1 if DMACn = 0 then INT.	16 states (1.6 μs)
0 1 1 Z	Transfer source address DEC mode ..... for I/O to memory (DMADn) ← (DMASn -) DMACn ← DMACn - 1 if DMACn = 0 then INT.	16 states (1.6 μs)
1 0 0 Z	Fixed address mode ..... I/O to I/O (DMADn) ← (DMASn) DMACn ← DMACn - 1 if DMACn = 0 then INT.	16 states (1.6 μs)
1 0 1 0	Read-only mode ..... for DRAM refresh Dummy ← (DMASn) ; Reads 4 bytes. DMASn ← DMASn + 4 ; Increments lower word only. DMACn ← DMACn - 1	14 states (1.4 μs)
1 0 1 1	Counter mode ..... for interrupt counter DMASn ← DMASn + 1 DMACn ← DMACn - 1 if DMACn = 0 then INT.	11 states (1.1 μs)

(1 state = 100ns)

This condition is 16-bit bus width and 0 wait of source / destination address space.

Note : n : corresponds to high-speed μDMA channels 0 to 3.  
 DMADn + / DMASn + : Post-increment (Increments register value after transfer.)  
 DMADn - / DMASn - : Post-decrement (Decrement register value after transfer.)

All address space (the space for system mode) can be accessed by high-speed μDMA.  
 Do not use undefined codes for transfer mode control.

## &lt; Usage of read only mode (DRAM refresh) &gt;

When the hardware configuration is as follows:

DRAM mapping size: = 1MB

DRAM data bus size: = 8 bits

DRAM mapping address range: = 100000H to 1FFFFFFH

Set the following registers first; refresh is performed automatically.

## ① Register initial value setting

LD XIX, 100000H

LDC DMAS0, XIX ... mapping start address

LD A, 00001010B

LDC DMAM0, A ... read only mode (for DRAM refresh)

## ② Timer setting

Set the timers so that interrupts are generated at intervals of  $62.5\mu\text{s}$  or less.

## ③ Interrupt controller setting

Set the timer interrupt mask higher than the other interrupts mask. Write the above timer interrupt vector value in the High-Speed  $\mu\text{DMA}$  start vector register, DMA0V.

## (Operation description)

The DRAM data bus is an 8-bit bus and the high-speed micro DMA is in read-only mode (4 bytes), so refresh is performed for four times per interrupt.

When a 512 refresh/8ms DRAM is connected, DRAM refresh is performed sufficiently if the high-speed micro DMA is started every  $15.625\mu\text{s} \times 4 = 62.4\mu\text{s}$  or less, since the timing is  $15.625\mu\text{s}/\text{refresh}$ .

## (Overhead)

Each processing time by the high-speed micro DMA is  $1.8\mu\text{s}$  (18 states) @20 MHz with an 8-bit data bus.

In the above example, the micro DMA is started every  $62.5\mu\text{s}$ ,  $1.8\mu\text{s}/62.5\mu\text{s} = 0.029$ ; thus, the overhead is 2.9%.

## (Note)

When the Bus is released (BUSAK="0") which must wait to accept the interrupt, DRAM refresh is not performed because of the high-speed  $\mu\text{DMA}$  is generated by an interrupt.

## 3.3.3 Interrupt Controller

Figure 3.3.3 (1) is a block diagram of the interrupt circuits. The left half of the diagram shows the interrupt controller; the right half includes the CPU interrupt request signal circuit and the HALT release signal circuit.

Each interrupt channel (total of 20 channels) in the interrupt controller has an interrupt request flip-flop, interrupt priority setting register, and a register for storing the high-speed micro DMA start vector. The interrupt request flip-flop is used to latch interrupt requests from peripheral devices. The flip-flop is cleared to 0 at reset, when the CPU reads the interrupt channel vector after the acceptance of interrupt, or when the CPU executes an instruction that clears the interrupt of that channel (writes 0 in the clear bit of the interrupt priority setting register).

For example, to clear the INT0 interrupt request, set the register after the DI instruction as follows.

INTE0AD ← ---- 0 --- Zero-clears the INT0 Flip Flop.

The status of the interrupt request flip-flop is detected by reading the clear bit. Detects whether there is an interrupt request for an interrupt channel.

The interrupt priority can be set by writing the priority in the interrupt priority setting register (eg, INTE0AD, INTE45, etc.) provided for each interrupt source. Interrupt levels to be set are from 1 to 6. Writing 0 or 7 as the interrupt priority disables the corresponding interrupt request. The priority of the non-maskable interrupt (NMI pin, watchdog timer, etc.) is fixed to 7. If interrupt requests with the same interrupt level are generated simultaneously, interrupts are accepted in accordance with the default priority (the smaller the vector value, the higher the priority).

The interrupt controller sends the interrupt request with the highest priority among the simultaneous interrupts and its vector address to the CPU. The CPU compares the priority value <IFF2 to 0> set in the Status Register by the interrupt request signal with the priority value sent; if the latter is higher, the interrupt is accepted. Then the CPU sets a value higher than the priority value by 1 in the CPU SR<IFF2 to 0>. Interrupt requests where the priority value equals or is higher than the set value are accepted simultaneously during the previous interrupt routine. When interrupt processing is completed (after execution of the RETI instruction), the CPU restores the priority value saved in the stack before the interrupt was generated to the CPU SR<IFF2 to 0>.

The interrupt controller also has four registers used to store the high-speed micro DMA start vector. These are I/O registers; unlike other high-speed micro DMA registers (DMAS, DMAD, DMAM, and DMAC), they can be accessed in either normal or system mode. Writing the start vector of the interrupt source for the high-speed micro DMA processing (see Table 3.3.(1)), enables the corresponding interrupt to be processed by high-speed micro DMA processing. The values must be set in the high-speed micro DMA parameter registers (eg, DMAS and DMAD) prior to the high-speed micro DMA processing.



(1) Interrupt priority setting register

(Read-modify-write prohibited.)

Symbol	Address	7	6	5	4	3	2	1	0
INTE0AD	0070H	INTAD				INT0			
		IADC	IADM2	IADM1	IADM0	I0C	I0M2	I0M1	I0M0
		R/W	W			R/W	W		
		0	0	0	0	0	0	0	
INTE45	0071H	INT5				INT4			
		I5C	I5M2	I5M1	I5M0	I4C	I4M2	I4M1	I4M0
		R/W	W			R/W	W		
		0	0	0	0	0	0	0	
INTE67	0072H	INT7				INT6			
		I7C	I7M2	I7M1	I7M0	I6C	I6M2	I6M1	I6M0
		R/W	W			R/W	W		
		0	0	0	0	0	0	0	
INTE10	0073H	INTT1 (Timer1)				INTT0 (Timer0)			
		IT1C	IT1M2	IT1M1	IT1M0	IT0C	IT0M2	IT0M1	IT0M0
		R/W	W			R/W	W		
		0	0	0	0	0	0	0	
INTEPW10	0074H	INTT3 (Timer3/PWM1)				INTT2 (Timer2/PWM0)			
		IPW1C	IPW1M2	IPW1M1	IPW1M0	IPW0C	IPW0M2	IPW0M1	IPW0M0
		R/W	W			R/W	W		
		0	0	0	0	0	0	0	
INTE54	0075H	INTTR5 (TREG5)				INTTR4 (TREG4)			
		IT5C	IT5M2	IT5M1	IT5M0	IT4C	IT4M2	IT4M1	IT4M0
		R/W	W			R/W	W		
		0	0	0	0	0	0	0	
INTE76	0076H	INTTR7 (TREG7)				INTTR6 (TREG6)			
		IT7C	IT7M2	IT7M1	IT7M0	IT6C	IT6M2	IT6M1	IT6M0
		R/W	W			R/W	W		
		0	0	0	0	0	0	0	
INTES0	0077H	INTTX0				INTRX0			
		ITX0C	ITX0M2	ITX0M1	ITX0M0	IRX0C	IRX0M2	IRX0M1	IRX0M0
		R/W	W			R/W	W		
		0	0	0	0	0	0	0	
INTES1	0078H	INTTX1				INTRX1			
		ITX1C	ITX1M2	ITX1M1	ITX1M0	IRX1C	IRX1M2	IRX1M1	IRX1M0
		R/W	W			R/W	W		
		0	0	0	0	0	0	0	

← Interrupt source  
 ← bit Symbol  
 ← Read/Write  
 ← After reset

ixxM2	ixxM1	ixxM0	Function (Write)
0	0	0	Prohibits interrupt request.
0	0	1	Sets interrupt request level to "1".
0	1	0	Sets interrupt request level to "2".
0	1	1	Sets interrupt request level to "3".
1	0	0	Sets interrupt request level to "4".
1	0	1	Sets interrupt request level to "5".
1	1	0	Sets interrupt request level to "6".
1	1	1	Prohibits interrupt request.

ixxC	Function (Read)	Function (Write)
0	Indicates no interrupt request.	Clears interrupt request flag.
1	Indicates interrupt request.	----- Don't care -----

(2) External interrupt control

Interrupt Input Mode Control Register

	7	6	5	4	3	2	1	0				
IIMC (007BH)						I0IE	I0LE	NMIREE				
bit Symbol										W	W	W
Read/Write										0	0	0
After reset												
Function						1: INT0 input enable	0: INT0 edge mode 1: INT0 level mode	1: Can be operated in NMI rising edge.				

Read-modify-write is prohibited.

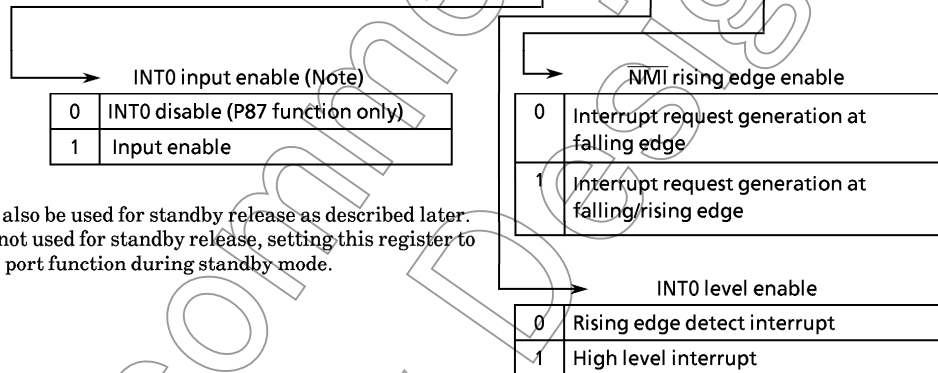

Note: The INT0 pin can also be used for standby release as described later. Even if the pin is not used for standby release, setting this register to "0" maintains the port function during standby mode.

Setting of External Interrupt Pin Functions

Interrupt	Pin name	Mode	Setting method
NMI	—	Falling edge	IIMC<NMIREE> = 0
		falling and Rising edges	IIMC<NMIREE> = 1
INT0	P87	Rising edge	IIMC<I0LE> = 0, <I0IE> = 1
		Level	IIMC<I0LE> = 1, <I0IE> = 1
INT4	P80	Rising edge	T4MOC<CAP12M1,0> = 0,0 or 0,1 or 1,1
		Falling edge	T4MOD<CAP12M1,0> = 1, 0
INT5	P81	Rising edge	—
INT6	P84	Rising edge	T5MOC<CAP34M1,0> = 0,0 or 0,1 or 1,1
		Falling edge	T5MOD<CAP34M1,0> = 1, 0
INT7	P85	Rising edge	—

## (3) High-speed micro DMA start vector

When the CPU reads the interrupt vector after accepting an interrupt, it simultaneously compares the interrupt vector with each channel's high-speed micro DMA start vector (bits 4 to 8 of the interrupt vector). When both match, the interrupt is processed in high-speed micro DMA mode for the channel whose value matched.

If the interrupt vector matches more than one channel, the channel with the lower channel number has a higher priority.

		Micro DMA0 Start Vector (read-modify-write is not possible.)							
		7	6	5	4	3	2	1	0
DMA0V (007CH)	bit Symbol				DMA0V8	DMA0V7	DMA0V6	DMA0V5	DMA0V4
	Read/Write							W	
	After reset				0	0	0	0	0

		Micro DMA1 Start Vector (read-modify-write is not possible.)							
		7	6	5	4	3	2	1	0
DMA1V (007DH)	bit Symbol				DMA1V8	DMA1V7	DMA1V6	DMA1V5	DMA1V4
	Read/Write							W	
	After reset				0	0	0	0	0

		Micro DMA2 Start Vector (read-modify-write is not possible.)							
		7	6	5	4	3	2	1	0
DMA2V (007EH)	bit Symbol				DMA2V8	DMA2V7	DMA2V6	DMA2V5	DMA2V4
	Read/Write							W	
	After reset				0	0	0	0	0

		Micro DMA3 Start Vector (read-modify-write is not possible.)							
		7	6	5	4	3	2	1	0
DMA3V (007FH)	bit Symbol				DMA3V8	DMA3V7	DMA3V6	DMA3V5	DMA3V4
	Read/Write							W	
	After reset				0	0	0	0	0

## (4) Notes

The instruction execution unit and the bus interface unit of this CPU operate independently of each other. Therefore, if the instruction used to clear an interrupt request flag of an interrupt is fetched before the interrupt is generated, it is possible that the CPU might execute the fetched instruction to clear the interrupt request flag while reading the interrupt vector after accepting the interrupt. If so, the CPU would read the default vector 00A0H and start the interrupt processing from the address 80A0H.

To avoid this, make sure that the instruction used to clear the interrupt request flag comes after the DI instruction.

In addition, take care as the following three circuits are exceptional and demand special attention.

INT0 level mode	<p>INT0 in level mode is not an edge-detect interrupt, so the interrupt request flip-flop function is canceled. The peripheral interrupt request bypasses the S input of the flip-flop, and acts as the Q output. Changing modes from edge to level automatically clears the interrupt request flag.</p> <p>If the CPU enters the interrupt response sequence as a result of setting INT0 from 0 to 1, INT0 must be held at 1 until the interrupt response sequence is completed. If the INT0 level mode is used to release a halt, INT0 must be held at 1 from the time INT0 changes from 0 to 1, to the time when the halt is released. (Ensure that INT0 does not go back 0 due to noise before the halt is released.)</p> <p>When switching modes from level to edge, any interrupt request flag set in level mode is not cleared. Accordingly, clear the interrupt request flag using the following sequence.</p> <pre>DI LD (IIMC), 00H ; Switches from level to edge. LD (INTEQAD), 00H ; Clears interrupt request flag. EI</pre>
INTAD	The interrupt request flip-flop can only be cleared by reset or by reading the A/D conversion result register, not by an instruction.
INTRX	The interrupt request flip-flop can only be cleared by reset or by reading the serial channel receive buffer, not by an instruction.

Note : The following instructions or pin changes are equivalent to instructions that clear the interrupt request flag.

- INT0 : Instructions that switch to level mode after an interrupt request is generated in edge mode.  
The pin input changes from high to low after an interrupt request is generated in level mode. ("H" → "L")
- INTAD : Instructions that read the A/D conversion result register.
- INTRX : Instructions that read the receive buffer.



### 3.4 Standby Function

When the HALT instruction is executed, the TMP96C141BF enters RUN, IDLE, or STOP mode depending on the contents of the HALT mode setting register.

- (1) RUN : Only the CPU halts; power consumption remains unchanged.
- (2) IDLE : Only the built-in oscillator operates, while all other built-in circuits halt. Power consumption is reduced to 1/10 or less than that during normal operation.
- (3) STOP : All internal circuits including the built-in oscillator halt. This greatly reduces power consumption.

The states of the port pins in STOP mode can be set as listed in Table 3.4 (1) using the I/O register WDMOD <DRVE> bit.

	7	6	5	4	3	2	1	0	
WDMOD (005CH)	bit Symbol	WDTE	WDTP1	WDTP0	WARM	HALTM1	HALTM0	RESCR	DRVE
	Read/Write	R/W							
	After reset	1	0	0	0	0	0	0	
	Function	1: WDT Enable	00: $2^{16}/fc$ 01: $2^{18}/fc$ 10: $2^{20}/fc$ 11: $2^{22}/fc$ Detection time	Warming up time	0: $2^{14}/fc$ 1: $2^{16}/fc$	Standby mode	00: RUN mode 01: STOP mode 10: IDLE mode 11: Don't care	1: Connects watchdog timer output to RESET pin internally.	1: Drive pin even in STOP mode.

When STOP mode is released by other than a reset, the system clock output starts after allowing some time for warming up set by the warming-up counter for stabilizing the built-in oscillator. To release STOP mode by a reset, it is necessary to allow a reset time long enough to allow the oscillator to stabilize.

To release standby mode, a reset or an interrupt is used. To release IDLE or STOP mode, only an interrupt by the NMI or INT0 pin, or a reset can be used. The details are described below.

Note: Usually, interrupts can release all halts status. However, the interrupts = (NMI, INT0), which can release the HALT mode may not be able to do so if they are input during the period CPU is shifting to the HALT mode (for about 3 clocks of X1) with IDLE or STOP mode. (In this case, an interrupt request is kept on hold internally.)

If another interrupt is generated after it has shifted to HALT mode completely, halt status can be released without difficulty. The priority of this interrupt is compare with that of the interrupt kept on hold internally, and the interrupt with higher priority is handled first followed by the other interrupt.

## Standby Release by Interrupt

Interrupt level Standby mode	Interrupt mask (IFF2 to 0) $\leq$ interrupt request level	Interrupt mask (IFF2 to 0) $>$ interrupt request level
RUN	Can be released by any interrupt. After standby mode is released, interrupt processing starts. (Note)	Can only be released by INT0 pin. Processing resumes from address next to HALT instruction.
IDLE	Can only be released by $\overline{\text{NMI}}$ or INT0 pin. After standby mode is released, interrupt processing starts. (Note)	↑
STOP	↑ (Note)	↑

Not Recommended for New Design

Table 3.4 (1) Pin states in STOP mode

Pin name	I/O	96C141BF		96CM40 / 96PM40	
		DRVE = 0	DRVE = 1	DRVE = 0	DRVE = 1
P0 (AD0 to AD7)	Input mode / AD0 to 7 Output mode	- x	- x	- -	- Output
P1 (AD8 to AD15)	Input mode / AD8 to 15 Output mode / A8 to 15	- x	- x	- -	- Output
P2	Input mode Output mode / A0 to 7, A16 to 23	PD* PD*	PD* Output	PD* PD*	PD* Output
P30 (RD), P31 (WR)	Output	-	"1" Output	-	Output
P32 to P37	Input mode Output mode	PU PU	PU Output		
P40, P41	Input mode Output mode	PU* PU*	PU Output		
P42 ( $\overline{CS2}$ / $\overline{CAS2}$ )	Input mode Output mode	PD* PD*	PD Output		
P5	Input	-	-		
P6	Input mode Output mode	PU* PU*	PU Output		
P7	Input mode Output mode	PU* PU*	PU Output		
P80 to P86	Input mode Output mode	PU* PU*	PU Output		
P87 (INT0)	Input mode Output mode	PU PU	PU Output		
P9	Input mode Output mode	PU* PU*	PU Output		
NMI	Input	Input	Input		
WDTOUT	Output	Output	Output		
ALE	Output	"0"	"0"		
CLK	Output	-	"1"		
RESET	Input	Input	Input		
EA	Input	Input	Input		
X1	Input	-	-		
X2	Output	"1"	"1"		

- : Input for input mode/input pin is invalid; output mode/output pin is at high impedance.

Input : Input enable state

Input : Input gate in operation. Fix input voltage to 0 or 1 so that input pin stays constant.

Output : Output state

PU : Programmable pull-up pin. Fix the pin to avoid through current since the input gate operates when a pull-up resistor is not set.

PD : Programmable pull-down pin. Fix the pin like a pull-up pin when a pull-down resistor is not set.

\* : Input gate disable state. No through current even if the pin is set to high impedance.

x : Cannot set.

Note : Port registers are used for controlling programmable pull-up/pull-down. If a pin is also used for an output function (eg, TO1) and the output function is specified, whether pull-up or pull-down is selected depends on the output function data. If a pin is also used for an input function, whether pull-up or pull-down is selected depends on the port register setting value only.

## 3.5 Functions of Ports

The TMP96C141BF, TMP96C041BF has 47 bits for I/O ports.

These port pins have I/O functions for the built-in CPU and internal I/Os as well as general-purpose I/O port functions. Table 3.5 lists the function of each port pin.

Table 3.5 Functions of Ports (R: ↑ = With programmable pull-up resistor  
↓ = With programmable pull-down)

Port name	Pin name	Number of pins	Direction	R	Direction setting unit	Pin name for built-in function
Port2	P20 to P27	8	I/O	↓	Bit	A0 to A7/A16 to A23
Port3	P32	1	I/O	↑	Bit	HWR
	P33	1	I/O	↑	Bit	WAIT
	P34	1	I/O	↑	Bit	BUSRQ
	P35	1	I/O	↑	Bit	BUSAK
	P36	1	I/O	↑	Bit	R/W
	P37	1	I/O	↑	Bit	RAS
Port4	P40	1	I/O	↑	Bit	CS0 / CAS0
	P41	1	I/O	↑	Bit	CS1 / CAS1
	P42	1	I/O	↓	Bit	CS2 / CAS2
Port5	P50 to P53	4	Input	-	(Fixed)	AN0 to AN3
Port6	P60 to P67	8	I/O	↑	Bit	PG00 to PG03, PG10 to PG13
Port7	P70	1	I/O	↑	Bit	TI0
	P71	1	I/O	↑	Bit	TO1
	P72	1	I/O	↑	Bit	TO2
	P73	1	I/O	↑	Bit	TO3
Port8	P80	1	I/O	↑	Bit	TI4/INT4
	P81	1	I/O	↑	Bit	TI5/INT5
	P82	1	I/O	↑	Bit	TO4
	P83	1	I/O	↑	Bit	TO5
	P84	1	I/O	↑	Bit	TI6/INT6
	P85	1	I/O	↑	Bit	TI7/INT7
	P86	1	I/O	↑	Bit	TO6
	P87	1	I/O	↑	Bit	INT0
Port9	P90	1	I/O	↑	Bit	TXD0
	P91	1	I/O	↑	Bit	RXD0
	P92	1	I/O	↑	Bit	CTS0 / SCLK0
	P93	1	I/O	↑	Bit	TXD1
	P94	1	I/O	↑	Bit	RXD1
	P95	1	I/O	↑	Bit	SCLK1

## I/O port Setting

X : Don't care

Port	Pin Name	Port (I/O) or Function	I/O Register		
			Pn	PnCR	PnFC
Port 2	P2 (0 : 7)	Input Port (No Pull-down)	1	0	-
		Input Port (With Pull-down)	0	0	
		Output Port	x	1	
		A (0 : 7) Output	1	0	
		A (16 : 23) Output	1	1	
Port 3	P3 (2 : 7)	Input Port (No Pull-up)	0	0	0
		Input Port (With Pull-up)	1	0	0
		Output Port	x	1	0
		HWR Output	x	1	1
	P32	WAIT Input (No Pull-up)	0	0	-
		WAIT Input (With Pull-up)	1	0	-
	P34	BUSRQ Input (No Pull-up)	0	0	1
		BUSRQ Input (With Pull-up)	1	0	1
	P35	BUSAK Output	x	1	1
	P36	R/W Output	x	1	1
	P37	RAS Output	x	1	1
Port 4	P4 (0 : 1)	Input Port (No Pull-up)	0	0	0
		Input Port (With Pull-up)	1	0	0
		Output Port	x	1	0
	P42	Input Port (No Pull-down)	1	0	0
		Input Port (With Pull-down)	0	0	0
		Output Port	x	1	0
	P40	CS0 Output (Note 1)	x	1	1
	P41	CS1 Output (Note 1)	x	1	1
	P42	CS2 Output (Note 1)	x	1	1
Port 5	P5 (0 : 3)	Input Port	x	-	
		AN (0 : 3) Input (Note 2)	x	-	
Port 6	P6 (0 : 7)	Input Port (No Pull-up)	0	0	0
		Input Port (With Pull-up)	1	0	0
		Output Port	x	1	0
		PGn Output	x	1	1
Port 7	P7 (0 : 3)	Input Port (No Pull-up)	0	0	0
		Input Port (With Pull-up)	1	0	0
		Output Port	x	1	0
	P70	TI0 Input (No Pull-up)	0	0	-
		TI0 Input (With Pull-up)	1	0	-
	P71	TO1 Output	x	1	1
	P72	TO2 Output	x	1	1
P73	TO3 Output	x	1	1	

Note 1: The function of P40 to P42 (CS0 to CS2, CA50 to CA52) is selected using CS/WAIT control register BnCS < BnCAS >.

Note 2: Select the input channels for the A/D converter in ADMOD < ADCHn >.

Port	Pin Name	Port (I/O) or Function	I/O Register		
			Pn	PnCR	PnFC
Port 8	P8 (0 : 7)	Input Port (No Pull-up)	0	0	0
		Input Port (With Pull-up)	1	0	0
		Output Port	x	1	0
	P80	TI4/INT4 Input (No Pull-up)	0	0	-
		TI4/INT4 Input (With Pull-up)	1	0	
	P81	TI5/INT5 Input (No Pull-up)	0	0	-
		TI5/INT5 Input (With Pull-up)	1	0	
	P84	TI6/INT6 Input (No Pull-up)	0	0	-
		TI6/INT6 Input (With Pull-up)	1	0	
	P85	TI7/INT7 Input (No Pull-up)	0	0	-
		TI7/INT7 Input (With Pull-up)	1	0	
	P82	TO4 Output	x	1	1
	P83	TO5 Output	x	1	1
	P86	TO6 Output	x	1	1
	P87 (Note 3)	INT0 Input (No Pull-up)	0	0	-
		INT0 Input (With Pull-up)	1	0	
	Port 9	P9 (0 : 5)	Input Port (No Pull-up)	0	0
Input Port (With Pull-up)			1	0	0
Output Port			x	1	0
P90		TXD0 Output	x	1	1
P93		TXD1 Output	x	1	1
		RXD0 Input (No Pull-up)	0	0	-
P91		RXD0 Input (With Pull-up)	1	0	
		P94	RXD1 Input (No Pull-up)	0	0
RXD1 Input (With Pull-up)			1	0	
P92		SCLK0 Output	x	1	1
		CTS0/SCLK0 Input (No Pull-up)	0	0	0
		CTS0/SCLK0 Input (With Pull-up)	1	0	0
P95		SCLK1 Output	x	1	1
		SCLK1 Input (No Pull-up)	0	0	0
		SCLK1 Input (With Pull-up)	1	0	0

Note 3: When P87 pin is used as INT0 pin, set IIMC<IOIE> to "1". (input enable)

Resetting makes the port pins listed below function as general-purpose I/O ports.  
 I/O pins programmable for input or output function as input ports.  
 To set port pins for built-in functions, a program is required.

#### Bus release function

TMP96C141B has the internal pull-up and pull-down resistors to fix the bus control signals at bus release.

Show the table 3.5 (1) of pin condition at bus release ( $\overline{\text{BUSAK}} = 0$ ).

Table 3.5 (1) The condition of pins at the bus release ( $\overline{\text{BUSAK}} = "L"$ )

pin name	the status of pins at bus release	
	port mode	function mode
AD0 to AD7 AD8 to AD15	—	these pins are "Hz".
$\overline{\text{RD}}$ $\overline{\text{WR}}$	—	these pins are "Hz". ("Hz" status after these pins driven high level)
P32 ( $\overline{\text{HWR}}$ ) P37 ( $\overline{\text{RAS}}$ )	The status is no change. (these pins are not "Hz".)	The output buffer is "OFF" after these pins driven high. These pins are added the internal resistor of pull-up. It's no relation for the value of output latch.
P36 ( $\text{R}/\overline{\text{W}}$ ) P40 ( $\overline{\text{CS0}}/\text{CAS0}$ ) P41 ( $\overline{\text{CS1}}/\text{CAS1}$ )	↑	↑
P42 ( $\overline{\text{CS2}}/\text{CAS2}$ )	↑	(*) ↑
P20 to P27 (A16 to 23)	↑	The output buffer is "OFF" after these pins driven low. These pins are added the internal resistor of pull-down. It's no relation for the value of output latch.

(\*) P42 has the resistor of programmable pull-down, but when the bus are released, P42 pin is added a resistor of pull-up.

That is, when it is used for bus release ( $\overline{\text{BUSAK}} = 0$ ), the pins of below need pull-up or pull-down resistor for an external circuit.

AD0 to AD7  
 AD8 to AD15  
 $\overline{\text{RD}}$   
 $\overline{\text{WR}}$

Case of the bus release function; show a sample of external bus interface in the Fig.3.5.

When the bus is released, both internal memory and internal I/O can not be accessed. But the internal I/O continues to run. So, the watchdog timer also continues to run. Therefore, be care about bus releasing time and set the detection time of WDT.

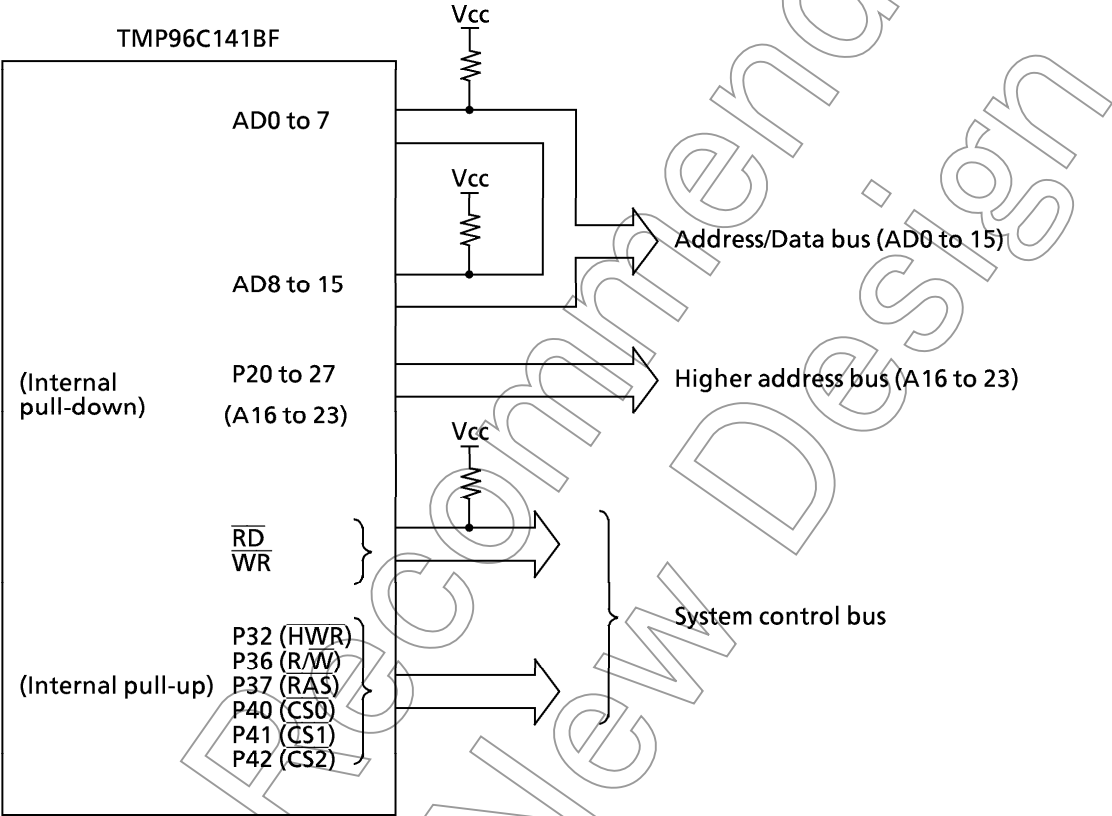

Fig.3.5 Example of the interface circuit (The case of using bus releasing function)



3.5.1 Port 2 (P20 to P27)

Port 2 is an 8-bit general-purpose I/O port. I/O can be set on bit basis using the control register P2CR and function register P2FC. Resetting resets all bits of output latch P2, control register P2CR and function register P2FC to 0. It also sets Port 2 to input mode and connects a pull-down resistor. To disconnect the pull-down resistor, write 1 in the output latch.

In addition to functioning as a general-purpose I/O port, Port 2 also functions as an address data bus (A0 to 7) and an address bus (A16 to 23). Setting to address bus, set P2CR and P2FC register in a row.

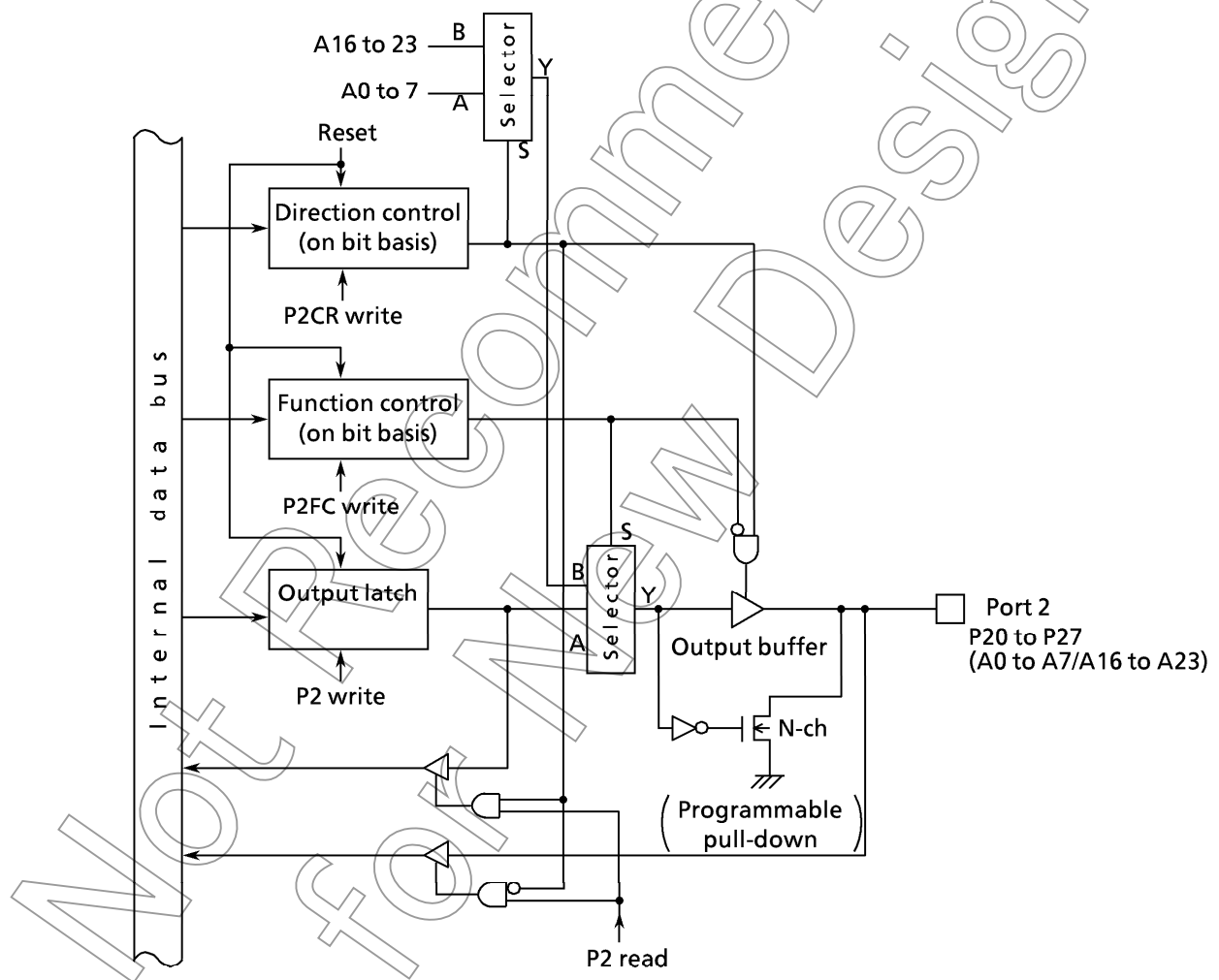

Figure 3.5 (1) Port 2

Port 2 Register

	7	6	5	4	3	2	1	0
bit Symbol	P27	P26	P25	P24	P23	P22	P21	P20
P2 (0006H) Read/Write	R/W							
After reset	Input mode (Output latch register is cleared to "0".)							

Port 2 Control Register

	7	6	5	4	3	2	1	0
bit Symbol	P27C	P26C	P25C	P24C	P23C	P22C	P21C	P20C
P2CR (0008H) Read/Write	W							
After reset	0	0	0	0	0	0	0	0
Function	<<See P2FC below.>>							

Port 2 Function Register

	7	6	5	4	3	2	1	0
bit Symbol	P27F	P26F	P25F	P24F	P23F	P22F	P21F	P20F
P2FC (0009H) Read/Write	W							
After reset	0	0	0	0	0	0	0	0
Function	P2FC/P2CR=00: IN, 01: OUT, 10: A7 to 0, 11: A23 to 16							

- Read-modify-write is prohibited for registers P2CR and P2FC.
- Read-modify-write is prohibited for controlling ON/OFF of the pull-down resistor for register P2.

→ Port 2 function setting

	P2FC<P2XF>	
P2CR <P2XC>	0	1
0	Input	address bus (A7 to 0)
1	Output	address bus (A23 to 16)

Note: <P2XF> is bit X in register P2FC; <P2XC>; in register P2CR. To set as an address bus A23 to 16, set P2FC after setting P2CR.

Figure 3.5 (2) Registers for Port 2

## 3.5.2 Port 3 (P30 to P37)

Port 3 is an 6-bit general-purpose I/O port.

I/O can be set on a bit basis. I/O is set using control register P3CR and function register P3FC. Resetting resets all bits of output latch P3 to 1, control register P3CR (bits 0 and 1 are unused) and function register P3FC (bit 3 is unused) to 0. Resetting also sets P32 to P37 to input mode, and connects a pull-up resistor.

In addition to functioning as a general-purpose I/O port, Port 3 also functions as an I/O for the CPU's control/status signal.

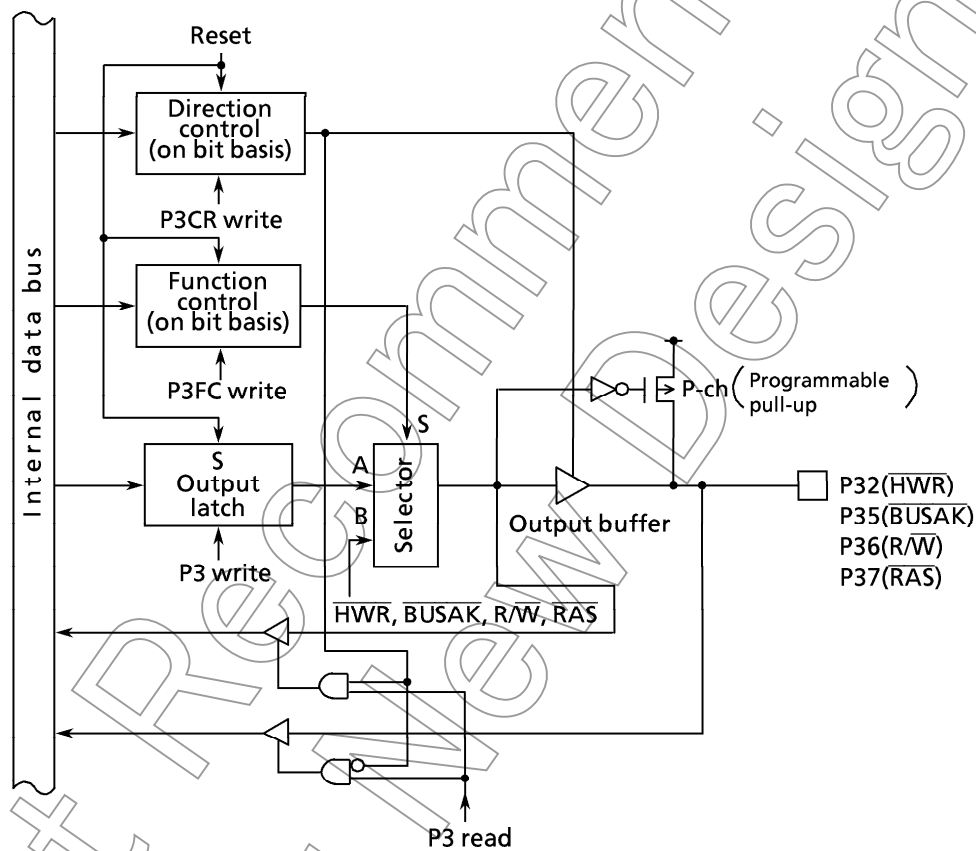

Figure 3.5 (3) Port 3 (P32, P35, P36, P37)

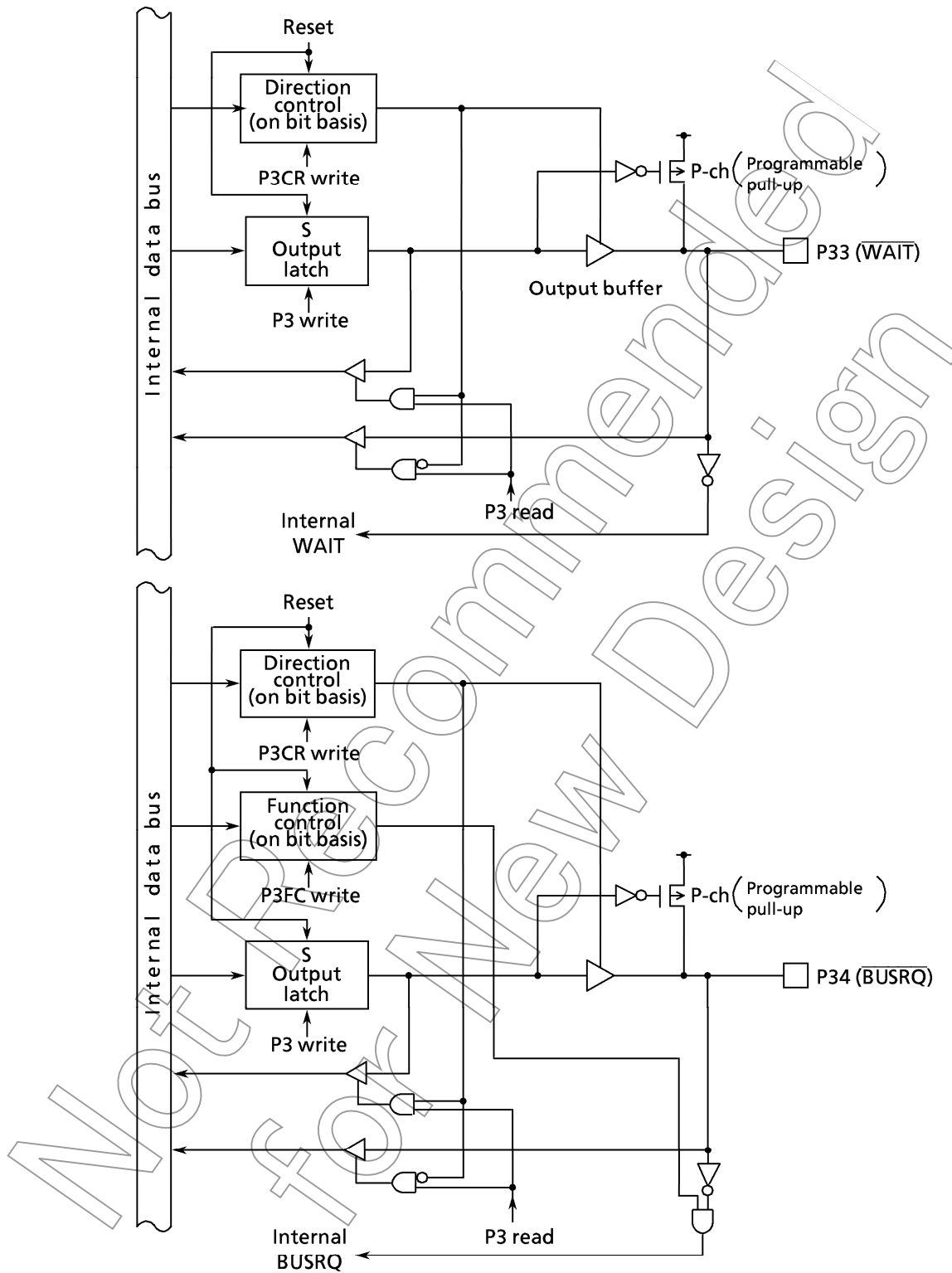
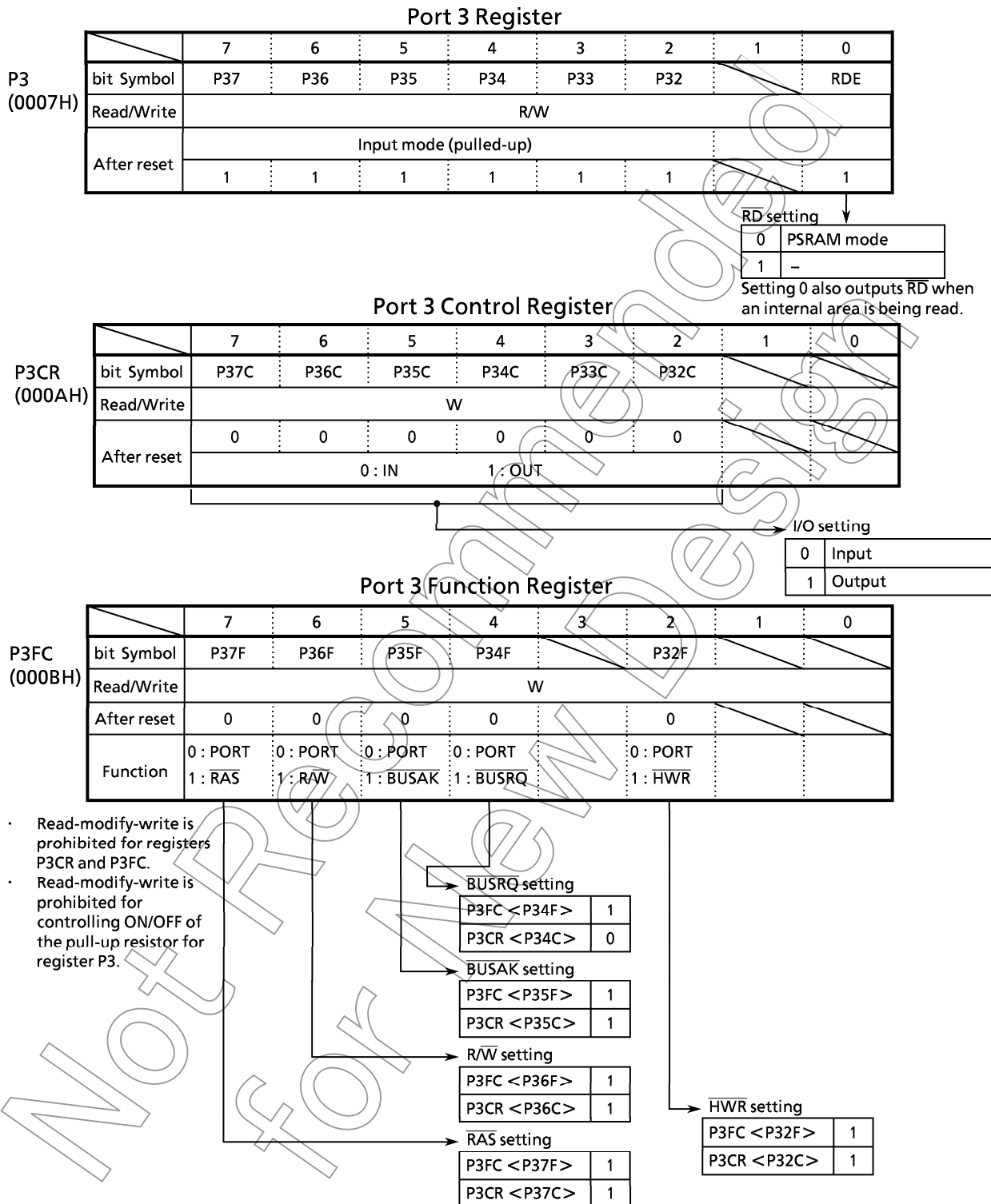

Figure 3.5 (4) Port3 (P33, P34)



Note: When P33/WAIT pin is used as a WAIT pin, set P3CR<P33C> to "0" and Chip Select / WAIT control register <BnW1,0> to "10".

Figure3.5 (5) Registers for Port 3

### 3.5.3 Port 4 (P40 to P42)

Port 4 is a 3-bit general-purpose I/O port. I/O can be set on a bit basis using control register P4CR and function register P4FC. Resetting does the following:

- Sets the P40 and P42 output latch registers to 1.
- Resets all bits of the P42 output latch register, the control register P4CR, and the function register P4FC to 0.
- Sets P40 and P41 to input mode and connects a pull-up resistor.
- Sets P42 to input mode and connects a pull-down resistor.

In addition to functioning as a general-purpose I/O port, Port 4 also functions as a chip select output signal ( $\overline{CS0}$  to  $\overline{CS2}$  or  $\overline{CAS0}$  to  $\overline{CAS2}$ ).

Not Recommended  
for New Design

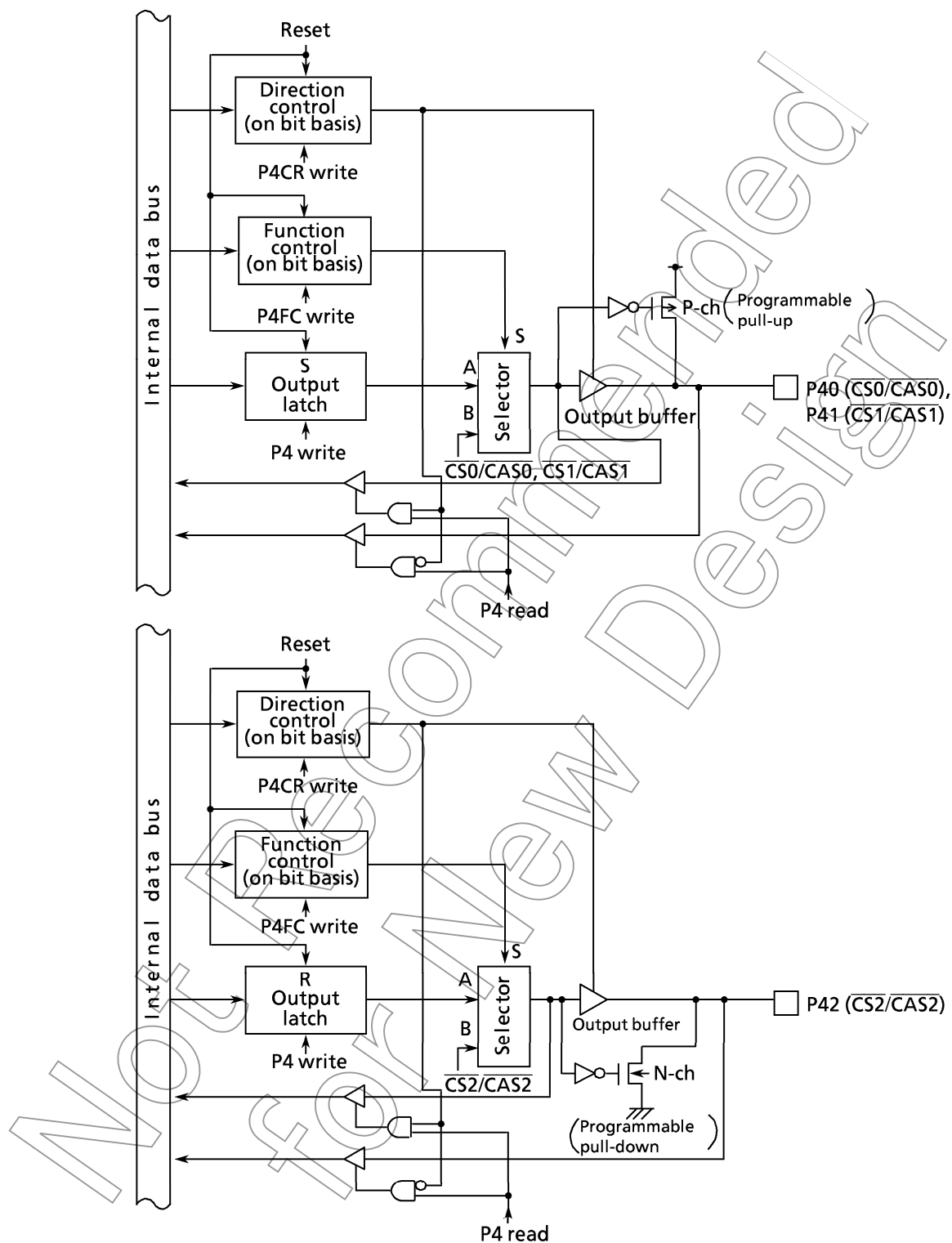

Figure 3.5 (6) Port 4

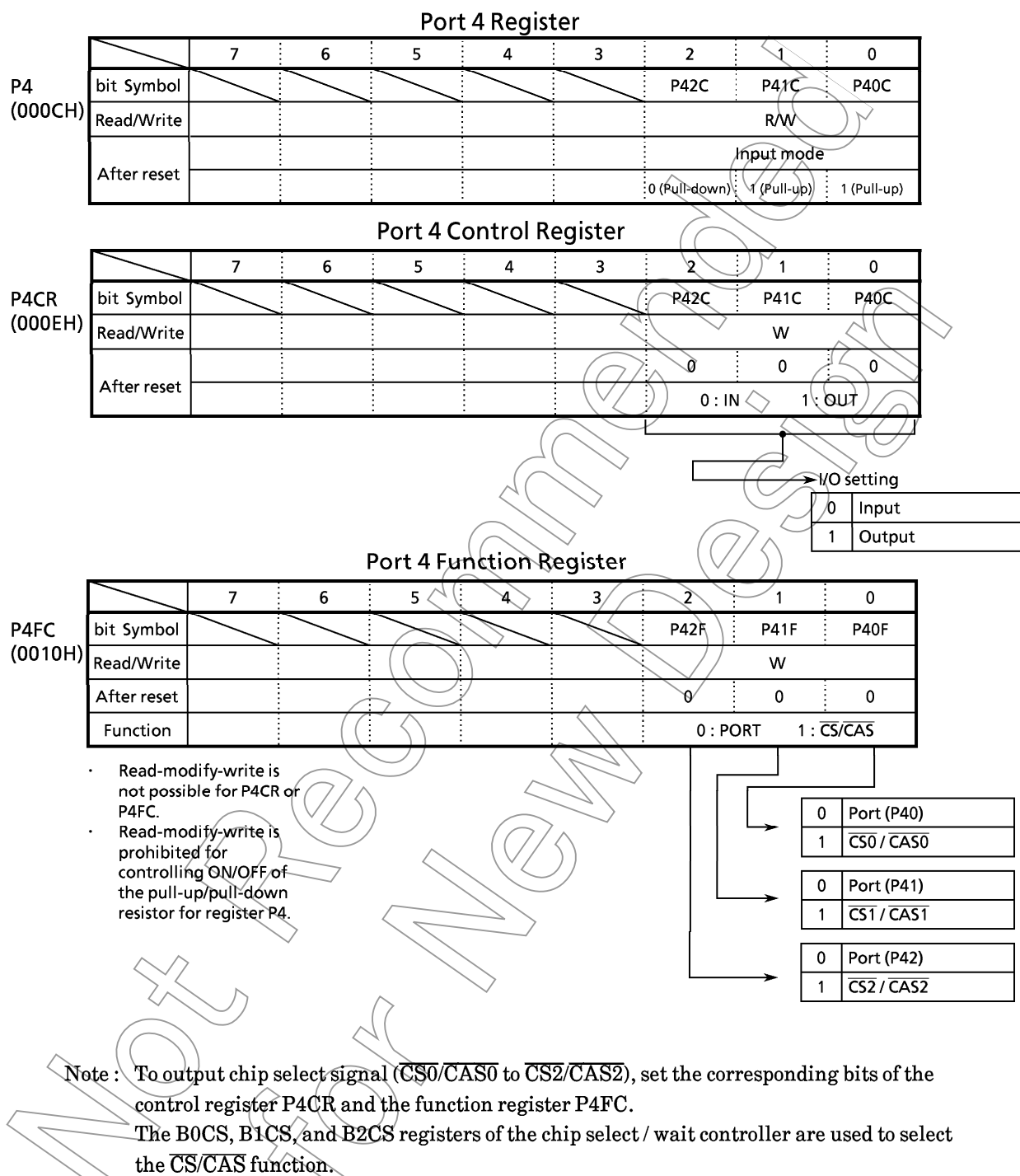

Figure 3.5 (7) Registers for Port 4

290591



3.5.4 Port 5 (P50 to P53)

Port 5 is a 4-bit input port, also used as an analog input pin.

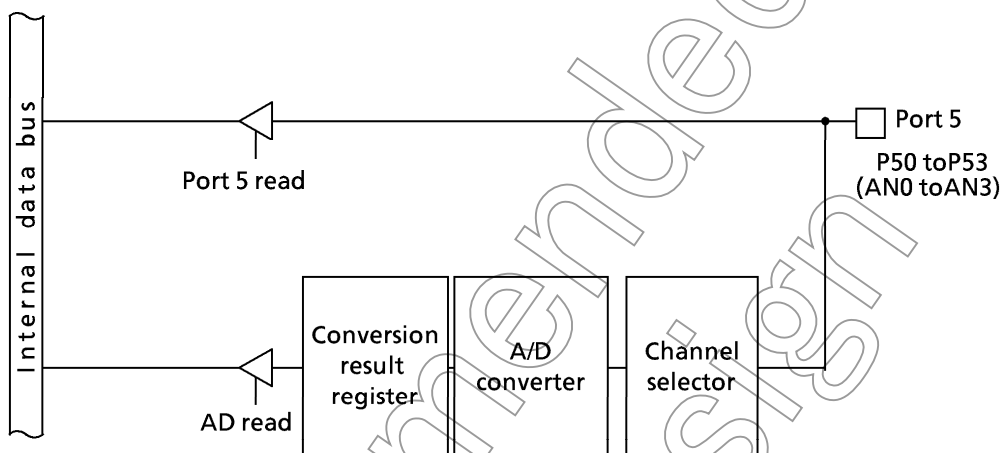

Figure 3.5 (8) Port 5

**Port 5 Register**

		7	6	5	4	3	2	1	0
P5 (000DH)	bit Symbol	/				P53	P52	P51	P50
	Read/Write	R							
	After reset	Input mode							

Note : The input channel selection of A/D Converter is set by A/D Converter mode register ADMOD.

Figure 3.5 (9) Registers for Port 5

Not for New

3.5.5 Port 6 (P60 to P67)

Port 6 is an 8-bit general-purpose I/O port. I/O can be set on bit basis. Resetting sets Port 6 as an input port and connects a pull-up resistor. It also sets all bits of the output latch to 1. In addition to functioning as a general-purpose I/O port, Port 6 also functions as a pattern generator PG0/PG1 output. PG0 is assigned to P60 to P63; PG1, to P64 to P67. Writing 1 in the corresponding bit of the port 6 function register (P6FC) enables PG output. Resetting resets the function register P6FC value to 0, and sets all bits to ports.

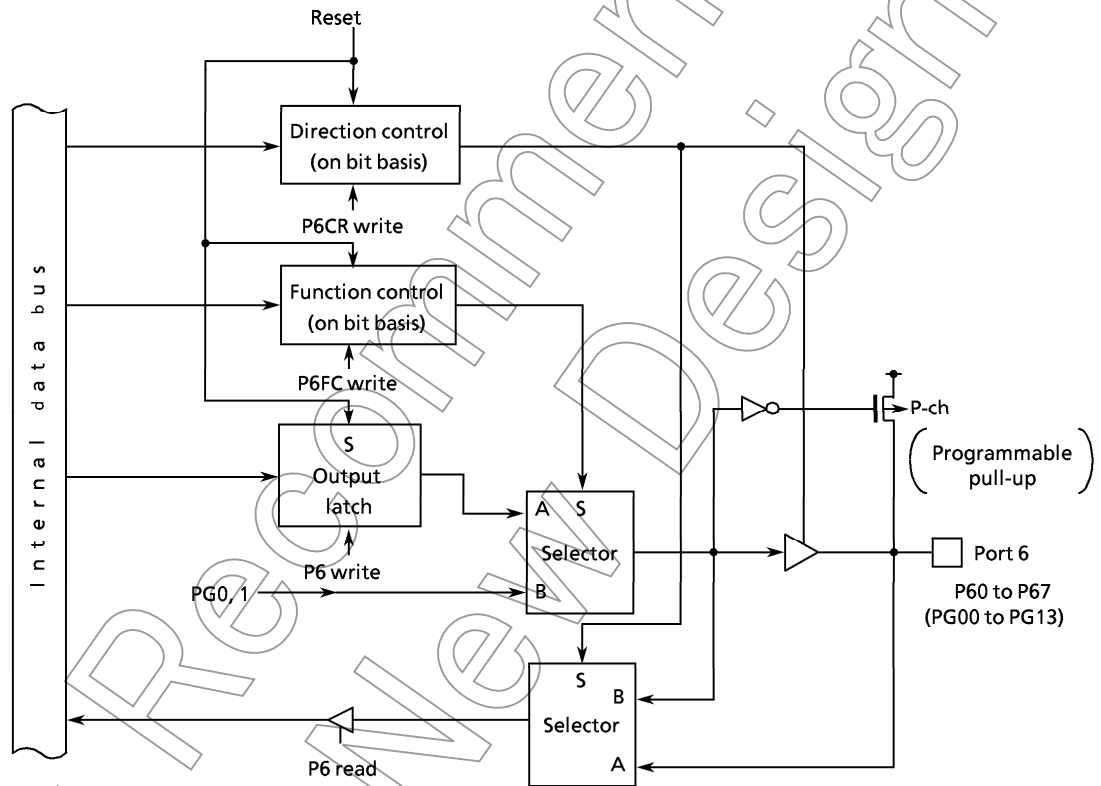

Figure 3.5 (10) Port 6

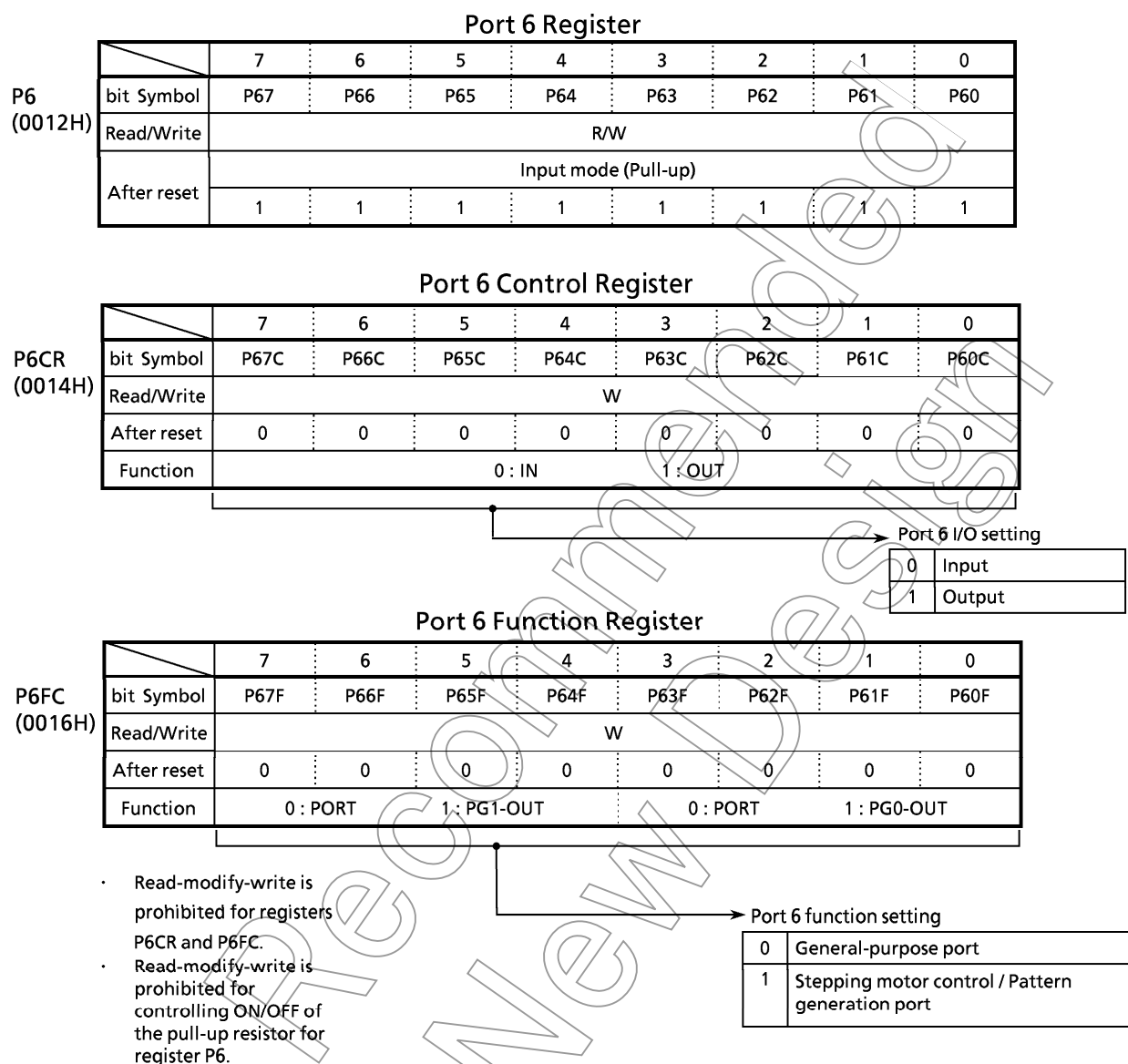

Figure3.5 (11) Registers for Port 6

3.5.6 Port 7 (P70 to P73)

Port 7 is a 4-bit general-purpose I/O port. I/O can be set on bit basis. Resetting sets Port 7 as an input port and connects a pull-up resistor. In addition to functioning as a general-purpose I/O port, Port 70 also functions as an input clock pin TIO; Port 71 as an 8-bit timer output (TO1), Port 72 as a PWM0 output (TO2), and Port 73 as a PWM1 output (TO3) pin. Writing 1 in the corresponding bit of the Port 7 function register (P7FC) enables output of the timer. Resetting resets the function register P7FC value to 0, and sets all bits to ports.

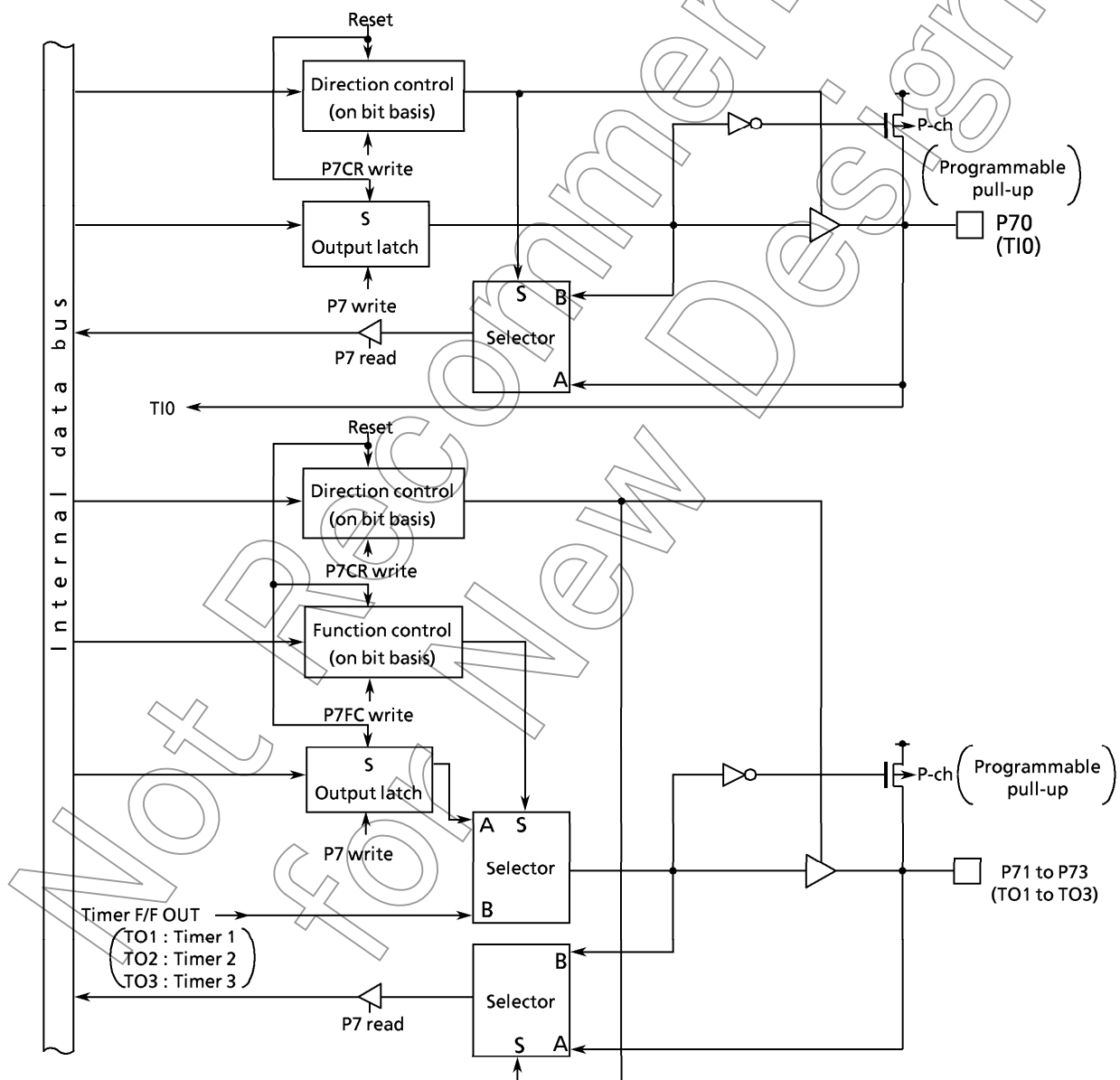

Figure 3.5 (12) Port 7

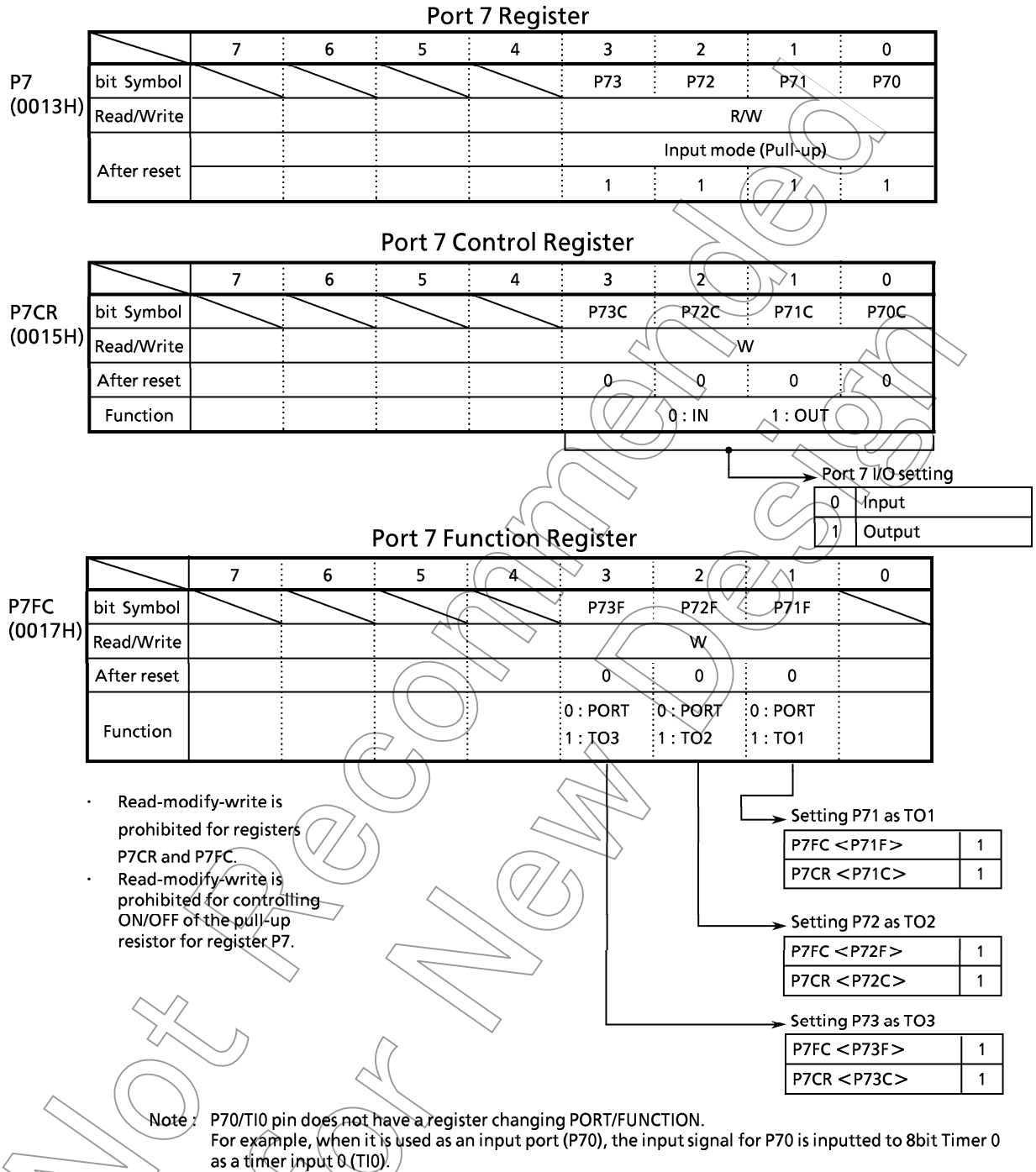

Figure3.5 (13) Registers for Port 7

3.5.7 Port 8 (P80 to P83)

Port 8 is an 8-bit general-purpose I/O port. I/O can be set on a bit basis. Resetting sets Port 8 as an input port and connects a pull-up resistor. It also sets all bits of the output latch register P8 to 1. In addition to functioning as a general-purpose I/O port, Port 8 also functions as an input for 16-bit timer 4 & 5 clocks, an output for 16-bit timer F/F 4, 5, & 6 output, and an input for INT0. Writing 1 in the corresponding bit of the Port 8 function register (P8FC) enables those functions. Resetting resets the function register P8FC value to 0 and sets all bits to ports.

(1) P80 to P86

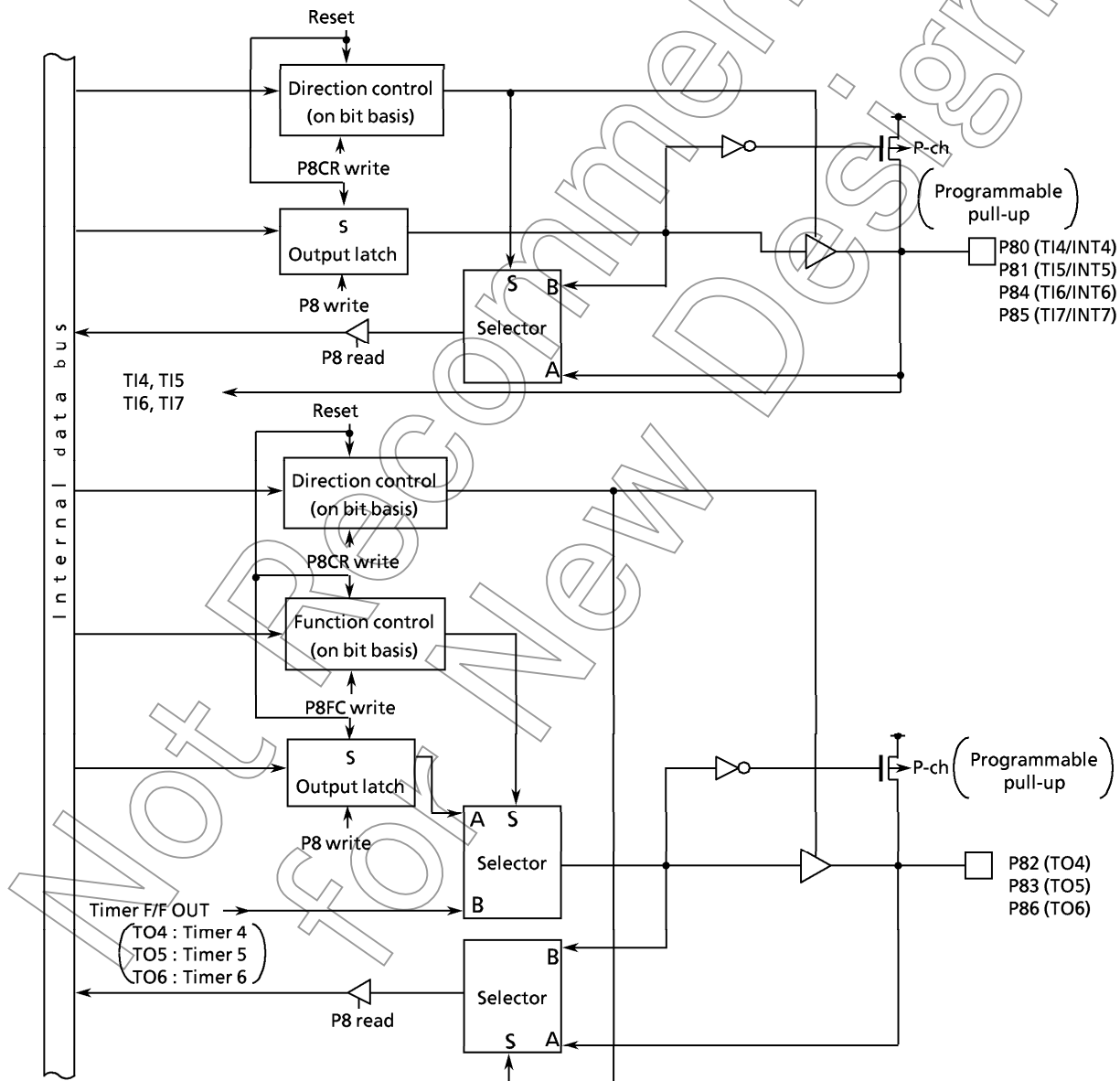

Figure 3.5 (14) Port 8 (P80 - P86)

(2) P87 (INT0)

Port 87 is a general-purpose I/O port, and also used as an INT0 pin for external interrupt request input.

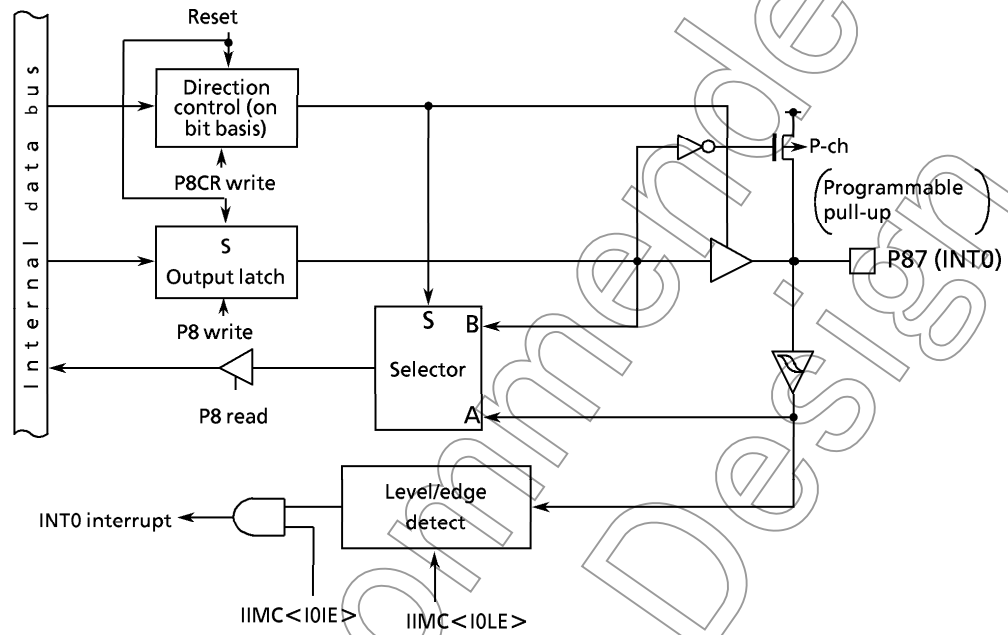

Figure 3.5 (15) Port 87

Not Recommended for New

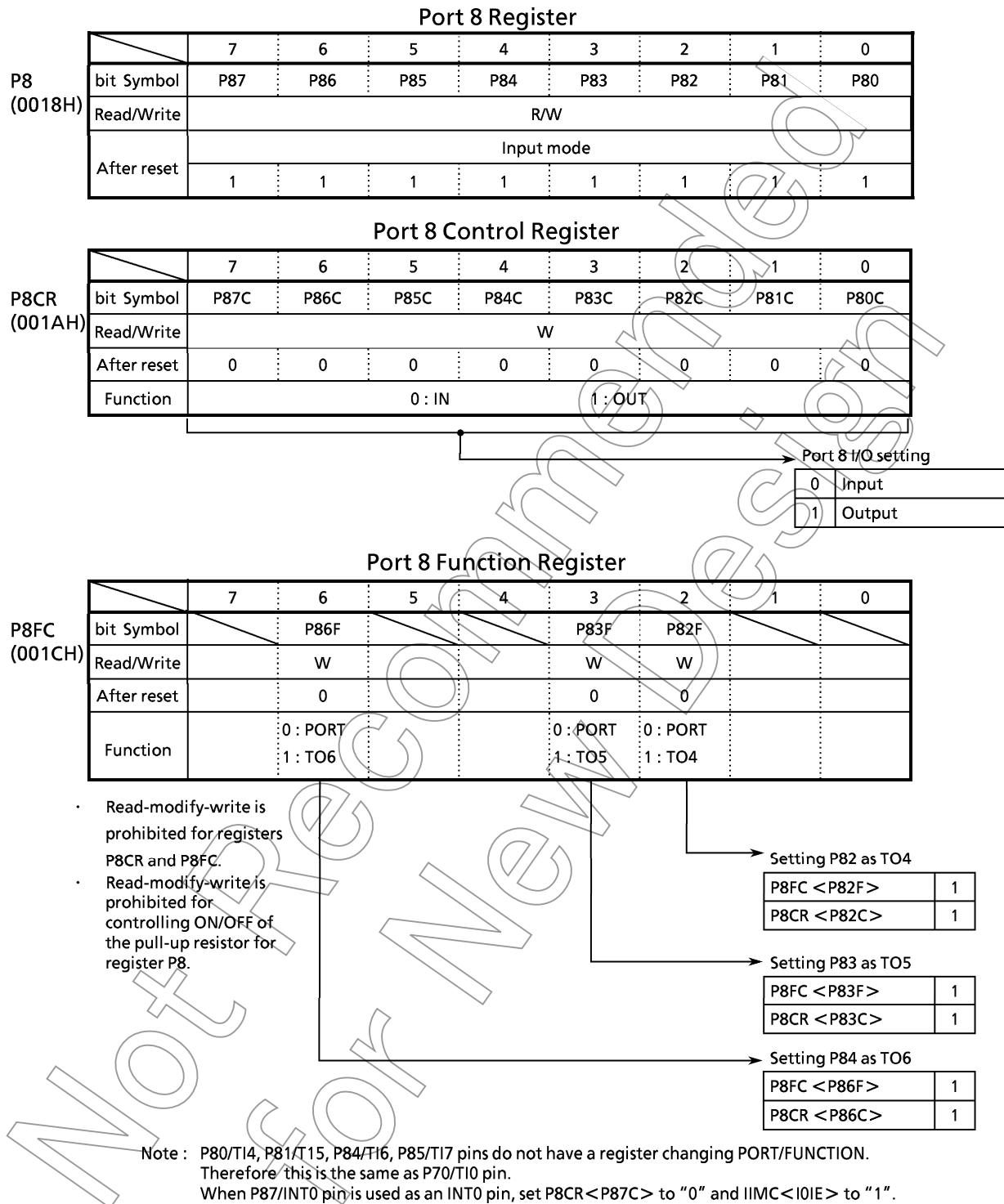

Figure3.5 (16) Registers for Port 8



### 3.5.8 Port 9 (P90 to P95)

Port 9 is a 6-bit general-purpose I/O port. I/Os can be set on a bit basis.

Resetting sets Port 9 to an input port and connects a pull-up resistor.

It also sets all bits of the output latch register to 1.

In addition to functioning as a general-purpose I/O port, Port 9 can also function as an I/O for serial channels 0 and 1. Writing 1 in the corresponding bit of the port 9 function register (P9FC) enables this function.

Resetting resets the function register value to 0 and sets all bits to ports.

#### (1) Port 90 and 93 (TXD0/TXD1)

Ports 90 and 93 also function as serial channel TXD output pins in addition to I/O ports.

They have a programmable open drain function.

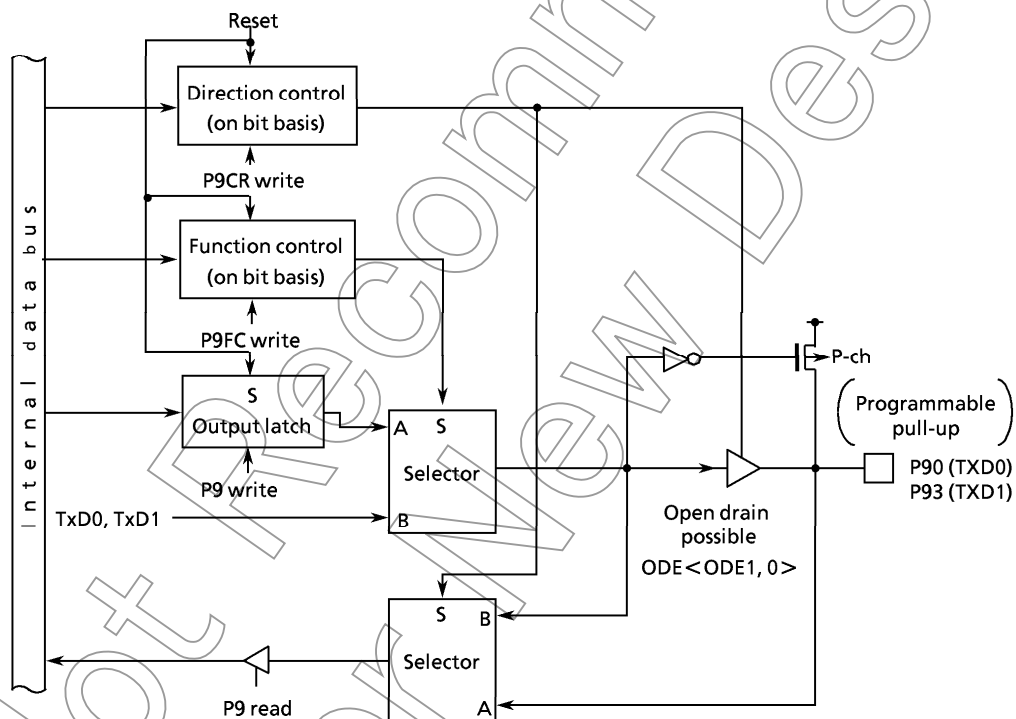

Figure 3.5 (17) Ports 90 and 93

(2) Ports 91 and 94 (RXD0, 1)

Ports 91 and 94 are I/O ports, and also used as RXD input pins for serial channels.

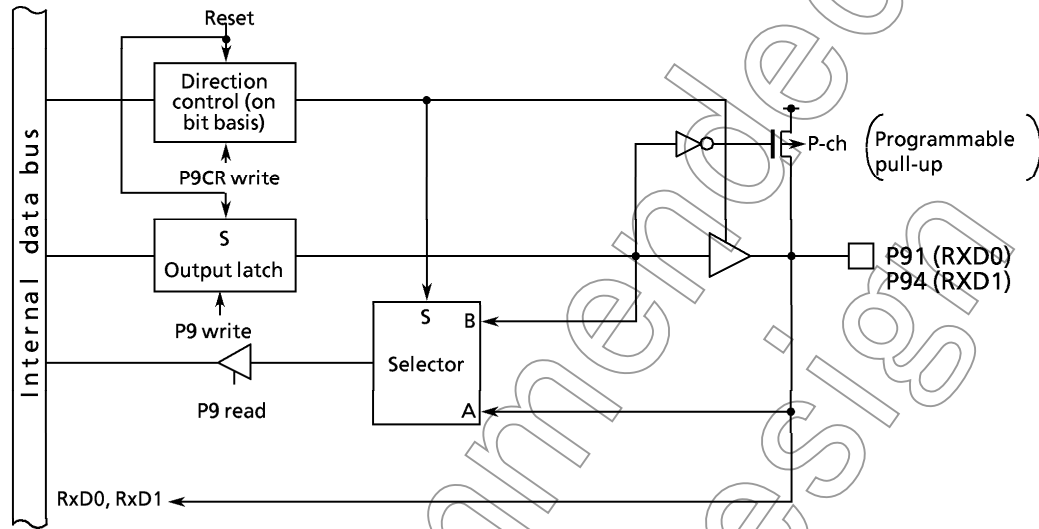

Figure3.5 (18) Ports 91 and 94

Not Recommended for New Design

(3) Port 92 ( $\overline{CTS0}/SCLK0$ )

Port 92 is an I/O port, and also used as a  $\overline{CTS0}$  input pin for serial channel0. Additionally, the  $\overline{CTS0}$  pin, and also as a SCLK0 I/O port.

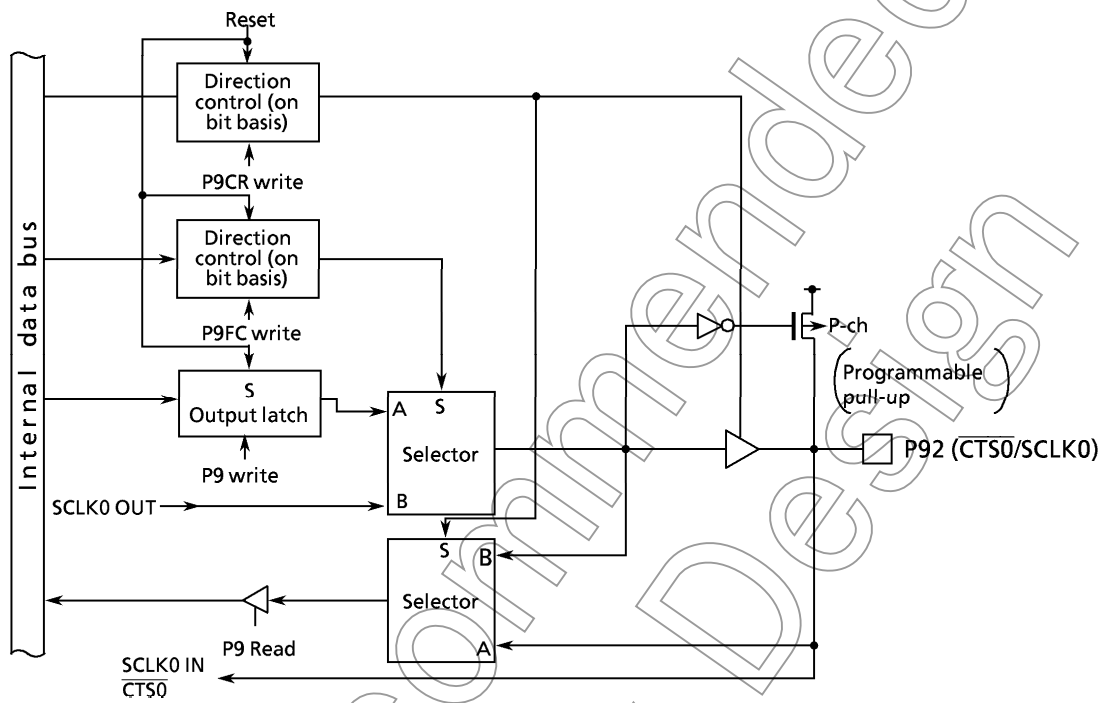

Figure3.5 (19) Ports 92

Not Recommended for New Design

(4) Port 95 (SCLK1)

Port 95 is a general-purpose I/O port. It is also used as an SCLK1 I/O pin for serial channel 1.

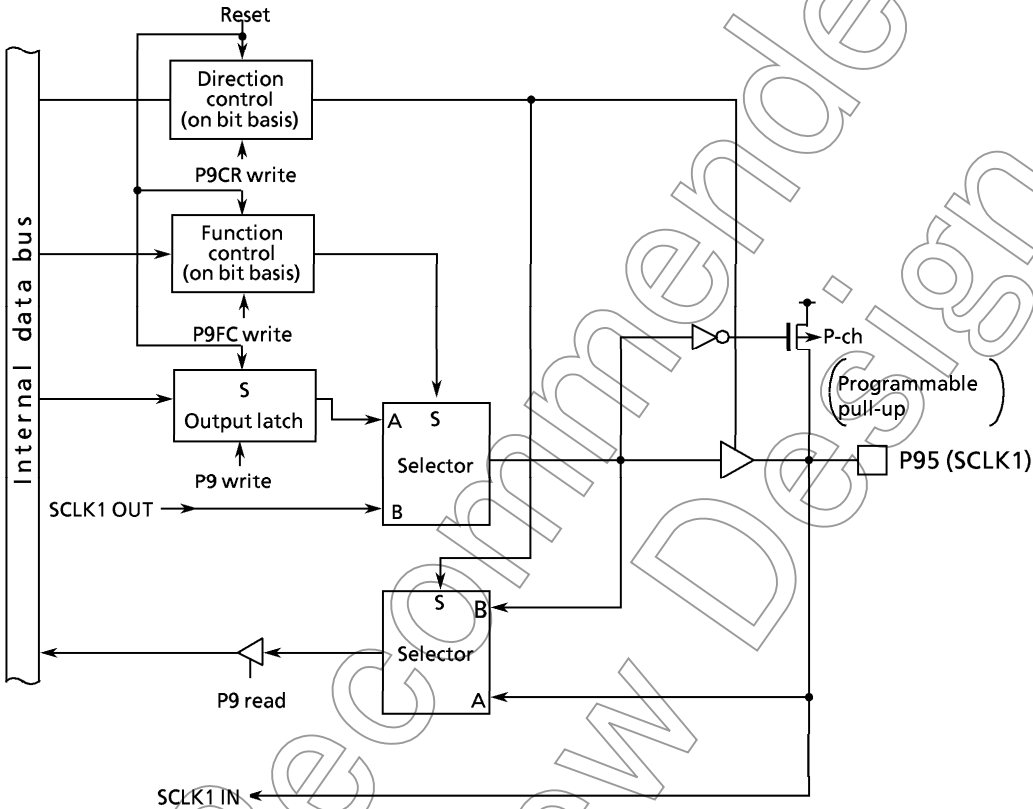

Figure3.5 (20) Port 95

Not Recommended for New Design

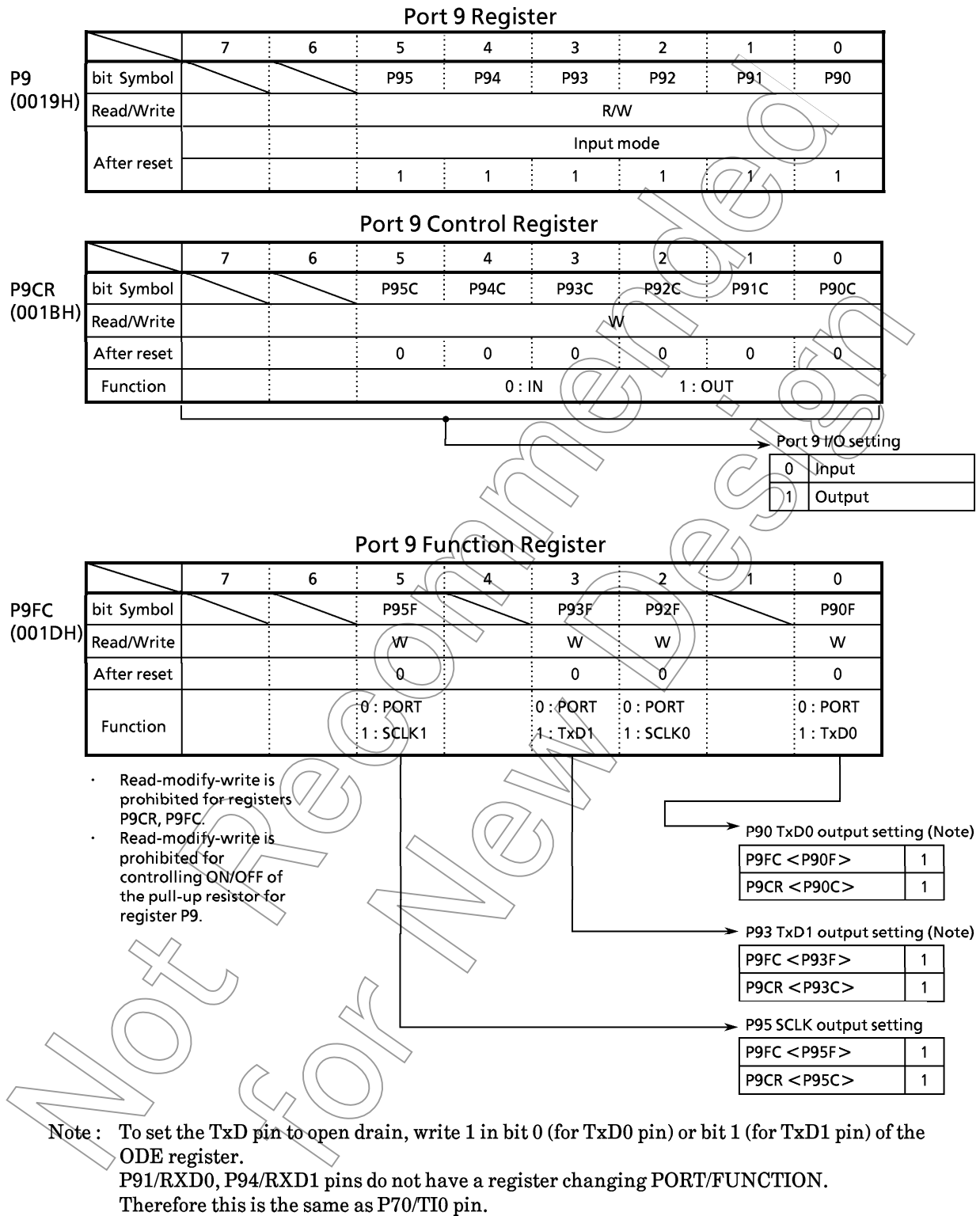

Figure 3.5 (21) Registers for Port 9

### 3.6 Chip Select / Wait Control

TMP96C141B has a built-in chip select / wait controller used to control chip select ( $\overline{CS0}$  to  $\overline{CS2}$  pins), wait ( $\overline{WAIT}$  pin), and data bus size (8 or 16 bits) for any of the three block address areas.

#### 3.6.1 Control Registers

Table 3.6.(1) shows control registers.

One block address areas are controlled by 1-byte CS/WAIT control registers (B0CS, B1CS, and B2CS). Registers can be written to only when the CPU is in system mode (there are two CPU modes: system and normal). The reason is that the settings of these registers have an important effect on the system.

##### (1) Enable

Control register bit 7 (B0E, B1E, and B2E) is a master bit used to specify enable (1) / disable (0) of the setting.

Resetting sets B0E and B1E to disable (0) and B2E to enable (1).

##### (2) System only specification

Control register bit 6 (B0SYS, B1SYS, and B2SYS) is used to specify enable / disable of the setting depending on the CPU operating mode (system or normal). Setting this bit to 0 enables setting (Address space for  $\overline{CS}$ , Wait state, Bus size, etc.) regardless of the CPU operating mode; setting it to 1 enables setting in system mode but disables setting in normal mode.

Resetting clears bit 6 to 0.

Bit 6 is mainly used when external memory data should not be accessed in normal mode (ie, for system mode only memory data for the operating system).

##### (3) CS/CAS Waveform select

Control register bit 5 (B0CAS, B1CAS, and B2CAS) is used to specify waveform mode output from the chip select pin ( $\overline{CS0/CAS0}$  to  $\overline{CS2/CAS2}$ ). Setting this bit to 0 specifies  $\overline{CS0}$  to  $\overline{CS2}$  waveforms; setting it to 1 specifies CAS0 to CAS2 waveforms.

Resetting clears bit 5 to 0.

#### (4) Data bus size select

Bit 4 (B0BUS, B1BUS, and B2BUS) of the control register is used to specify data bus size. Setting this bit to 0 accesses the memory in 16-bit data bus mode; setting it to 1 accesses the memory in 8-bit data bus mode.

Changing data bus size depending on the access address is called dynamic bus sizing. Table 3.6 (2) shows the details of the bus operation.

#### (5) Wait control

Control register bits 3 and 2 (B0W1,0; B1W1,0; B2W1,0) are used to specify the number of waits. Setting these bits to 00 inserts a 2-state wait regardless of the  $\overline{\text{WAIT}}$  pin status. Setting them to 01 inserts a 1-state wait regardless of the  $\overline{\text{WAIT}}$  status. Setting them to 10 inserts a 1-state wait and samples the  $\overline{\text{WAIT}}$  pin status. If the pin is low, inserting the wait maintains the bus cycle until the pin goes high. Setting them to 11 completes the bus cycle without a wait regardless of the  $\overline{\text{WAIT}}$  pin status.

Resetting sets these bits to 00 (2-state wait mode).

#### (6) Address area specification

Control register bits 1 and 0 (B0C1,0; B1C1,0; B2C1,0) are used to specify the target address area. Setting these bits to 00 enables settings (CS output, Wait state, Bus size, etc.) as follows:

- \* CS0 setting enabled when 7F00H to 7FFFH is accessed.
- \* CS1 setting enabled when 480H to 7FFFH is accessed.  
CS1 setting enable when 80H to 7FFFH is accessed for the TMP96C041B, which does not have a built-in RAM.
- \* CS2 setting enabled when 8000H to 3FFFFFFH is accessed.  
CS2 setting enabled when 10000H to 3FFFFFFH is accessed for the TMP96CM40/TMP96PM40, which has built-in 32 Kbyte ROM/PROM..

Setting bits to 01 enables setting for all CS's blocks and outputs a low strobe signal ( $\overline{\text{CS0/CAS0}}$  to  $\overline{\text{CS2/CAS2}}$ ) from chip select pins when 400000H to 7FFFFFFH is accessed. Setting bits to 10 enables them 800000H to BFFFFFFH is accessed. Setting bits to 11 enables them when C00000H to FFFFFFFH is accessed.

Table 3.6 (1) Chip select / wait control register

Code	Name	Address	7	6	5	4	3	2	1	0
B0CS	Block0 CS/WAIT control register	0068H	B0E	B0SYS	B0CAS	B0BUS	B0W1	B0W0	B0C1	B0C0
			W	W	W	W	W	W	W	W
			0	0	0	0	0	0	0	0
			1: CS/CAS Enable	1: SYSTEM only	0: CS0 1: CAS0	0: 16bit Bus 1: 8bit Bus	00: 2WAIT 01: 1WAIT 10: 1WAIT + n 11: 0WAIT		00: 7F00H to 7FFFH 01: 400000H to 10: 800000H to 11: C00000H to	
B1CS	Block1 CS/WAIT control register	0069H	B1E	B1SYS	B1CAS	B1BUS	B1W1	B1W0	B1C1	B1C0
			W	W	W	W	W	W	W	W
			0	0	0	0	0	0	0	0
			1: CS/CAS Enable	1: SYSTEM only	0: CS1 1: CAS1	0: 16bit Bus 1: 8bit Bus	00: 2WAIT 01: 1WAIT 10: 1WAIT + n 11: 0WAIT		*00: 480H to 7FFFH 01: 400000H to 10: 800000H to 11: C00000H to	
B2CS	Block2 CS/WAIT control register	006AH	B2E	B2SYS	B2CAS	B2BUS	B2W1	B2W0	B2C1	B2C0
			W	W	W	W	W	W	W	W
			1	0	0	0	0	0	0	0
			1: CS/CAS Enable	1: SYSTEM only	0: CS2 1: CAS2	0: 16bit Bus 1: 8bit Bus	00: 2WAIT 01: 1WAIT 10: 1WAIT + n 11: 0WAIT		00: 8000H to 01: 400000H to 10: 800000H to 11: C00000H to	

Note : With only block 2, enable (16-bit data bus, 2-wait mode) after reset.

Table 3.6 (2) Dynamic bus sizing

Operand data size	Operand start address	Memory data size	CPU address	CPU data	
				D15 to D8	D7 to D0
8 bits	2n + 0 (even number)	8 bits	2n + 0	xxxxx	b7 to b0
		16 bits	2n + 0	xxxxx	b7 to b0
	2n + 1 (odd number)	8 bits	2n + 1	xxxxx	b7 to b0
		16 bits	2n + 1	b7 to b0	xxxxx
16 bits	2n + 0 (even number)	8 bits	2n + 0	xxxxx	b7 to b0
		8 bits	2n + 1	xxxxx	b15 to b8
		16 bits	2n + 0	b15 to b8	b7 to b0
	2n + 1 (odd number)	8 bits	2n + 1	xxxxx	b7 to b0
		8 bits	2n + 2	xxxxx	b15 to b8
		16 bits	2n + 1	b7 to b0	xxxxx
32 bits	2n + 0 (even number)	8 bits	2n + 0	xxxxx	b7 to b0
			2n + 1	xxxxx	b15 to b8
			2n + 2	xxxxx	b23 to b16
			2n + 3	xxxxx	b31 to b24
		16 bits	2n + 0	b15 to b8	b7 to b0
			2n + 2	b31 to b24	b23 to b16
	2n + 1 (odd number)	8 bits	2n + 1	xxxxx	b7 to b0
			2n + 2	xxxxx	b15 to b8
			2n + 3	xxxxx	b23 to b16
			2n + 4	xxxxx	b31 to b24
		16 bits	2n + 1	b7 to b0	xxxxx
			2n + 2	b23 to b16	b15 to b8
			2n + 4	xxxxx	b31 to b24

xxxxx : During a read, data input to the bus is ignored. At write, the bus is at high impedance and the write strobe signal remains non-active.



### 3.6.2 Chip Select Image

An image of the actual chip select is shown below. Out of the whole memory area, address areas that can be specified are divided into four parts. Addresses from 000000H to 3FFFFFFH are divided differently: 7F00H to 7FFFH is specified for CS0; 480H to 7FFFH, for CS1; and 8000H to 3FFFFFFH, for CS2. The reason is that a device other than ROM (ie, RAM or I/O) might be connected externally.

7F00H to 7FFFH (256 bytes) for CS0 are mapped mainly for possible expansions to external I/O.

480H to 7FFFH (approx. 31 Kbytes) for CS1 are mapped there mainly for possible extensions to external RAM.

8000H to 3FFFFFFH (approx. 4 Mbytes) for CS2 are mapped mainly for possible extensions to external ROM. After reset, CS2 is enabled in 16-bit bus and 2-wait. With the TMP96C141B, which does not have a built-in ROM, the program is externally read at address 8000H in this setting (16-bit bus, 2-wait). With the TMP96CM40/TMP96PM40, which has a built-in ROM, addresses from 8000H to FFFFFFFH are used as the internal ROM area; CS2 is disabled in this area. After reset, the CPU reads the program from the built-in ROM in 16-bit bus, 0-wait mode.

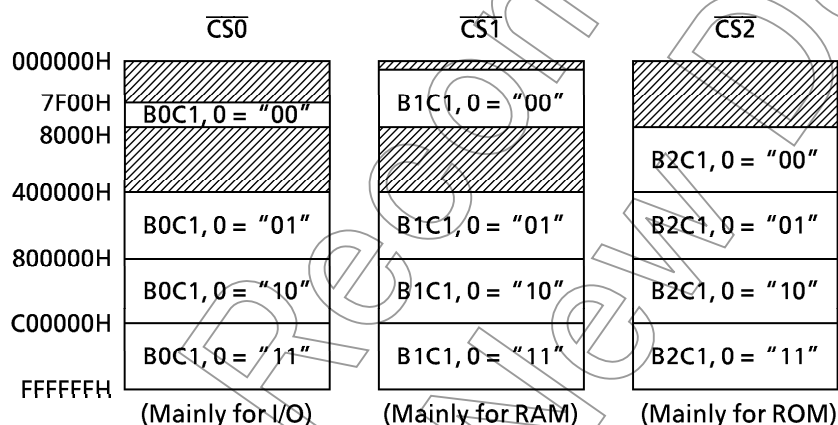

Supplement 1: Access priority is highest for built-in I/O, then built-in memory, and lowest for the chip select/wait controller.

Supplement 2: External areas other than  $\overline{CS0}$  to  $\overline{CS2}$  are accessed in 16-bit data bus ( 0 wait) mode.

When using the chip select/wait controller, do not specify the same address area more than once. (However, when addresses 7F00H to 7FFFH for CS0 and 480H to 7FFFH for CS1 are specified, in other words, specifications overlap, only the CS0 setting/pin is active.)

Note: When the bus is released ( $\overline{BUSA}K = "0"$ ),  $\overline{CS0}$  to  $\overline{CS2}$  pins are also released (the output buffer is OFF). Refer to 「 Note about the bus release 」 in 3.5 Functions of Ports about the state of pins.

3.6.3 Example of Usage

Figure 3.6 (1) is an example in which an external memory is connected to the TMP96C141B. In this example, a ROM is connected using 16 bit Bus; a RAM is connected using 8 bit Bus.

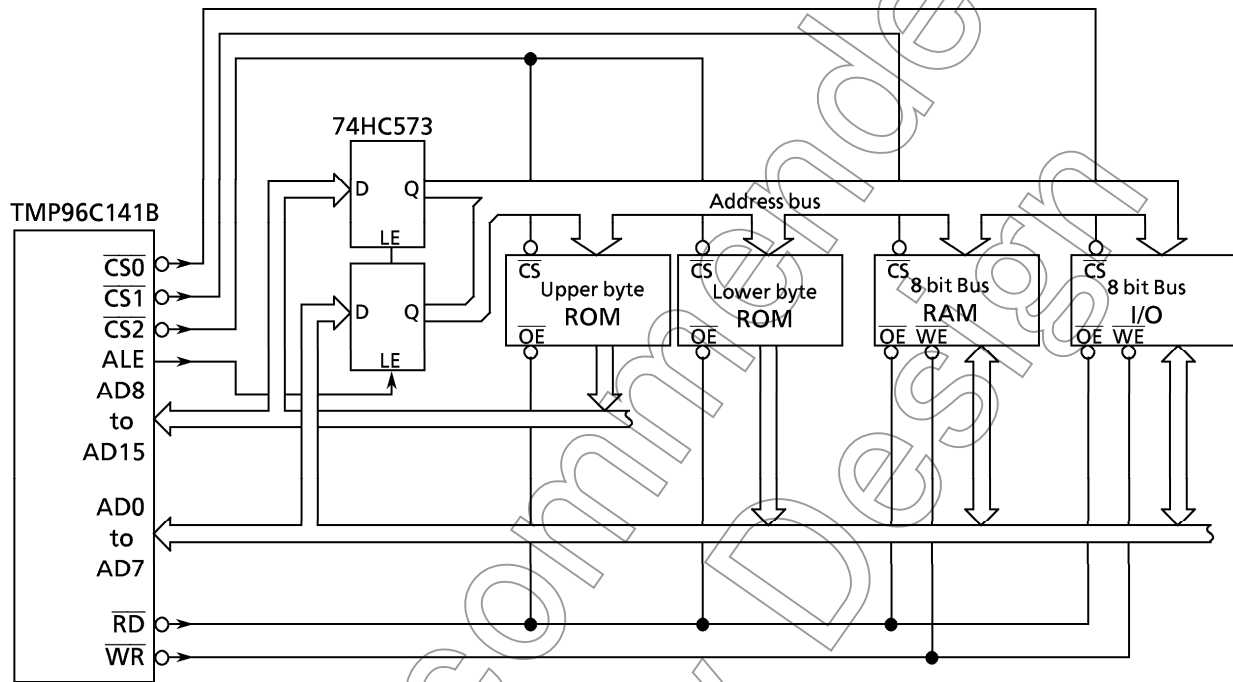

Figure 3.6 (1) Example of External Memory Connection (ROM = 16 bits, RAM & I/O = 8 bits)

Resetting sets pins CS0 to CS2 to input port mode. CS0 and CS1 are set high due to an internal pull-up resistor; CS2, low due to an internal pull-down resistor. The program used to set these pins is as follows.

```

P4CR EQU 0EH
P4FC EQU 10H
B0CS EQU 68H
B1CS EQU 69H
B2CS EQU 6AH
LD (B0CS), 90H ; CS0 = 8 bits, 2WAIT, 7F00H to 7FFFH
LD (B1CS), 9CH ; CS1 = 8 bits, 0WAIT, 480H to 7EFFH
LD (B2CS), 84H ; CS2 = 16 bits, 1WAIT, 8000H to 3FFFFFH
LD (P4CR), 07H
LD (P4FC), 07H
    
```

} CS0, CS1, CS2 output mode setting

### 3.6.4 How to Start with an 8-bit Data Bus

Resetting sets the  $\overline{CS2}$  pin low due to an internal pull-down resistor; memory access starts in 16-bit data bus (2-wait) mode. To start in 8-bit data bus mode, a special operation is required. Operation is as described in the example below.

```

B2CS EQU 6AH ; CS2 register address
ORG 8000H ; RESET address
LDX (B2CS), 9CH ; CS2 8bit, 0WAIT, 8000H to
    
```

After reset, the program reads the LDX(B2CS),9CH instruction in 16-bit data bus mode. LDX is a 6-byte instruction: the 2nd, 4th, and 6th bytes are handled as dummies (ie, only codes in the 1st, 3rd, and 5th bytes are actually used). Even if starting in 8-bit data bus mode, it is possible to program so that the LDX instruction is executed and the CS 2 area (8000H - 3FFFFFFH) is accessed in 8-bit data bus mode without any problem.

The above program does not include setting the P42/ $\overline{CS2}$  pin to output; add a program to set the P4CR and P4FC registers as required.

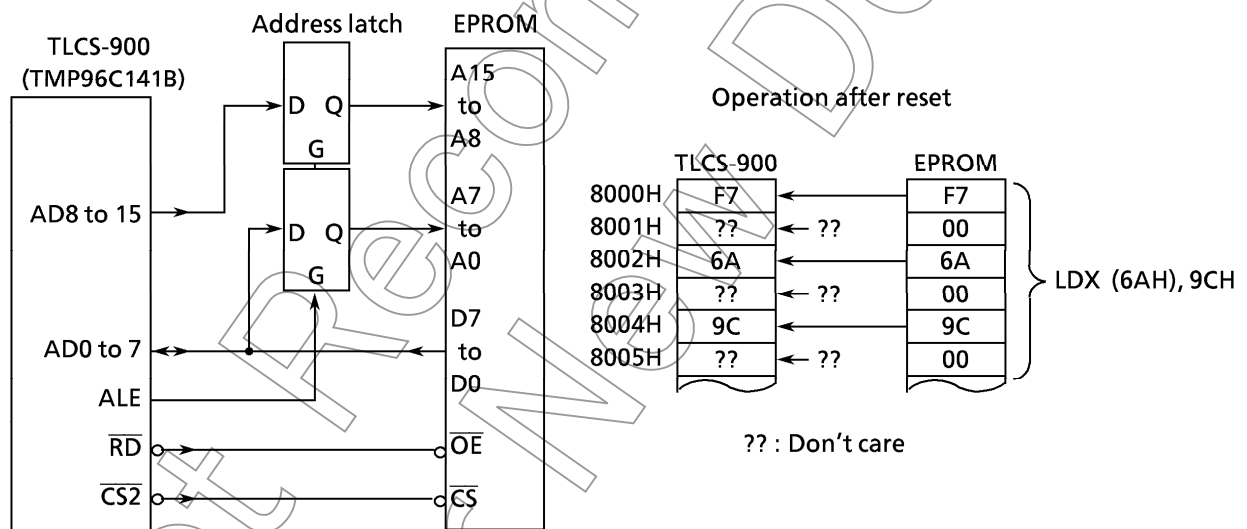

### 3.7 8-bit Timers

TMP96C141B has two 8-bit timers (timers 0 and 1), each of which can be operated independently. The cascade connection allows these timers to be used as 16-bit timer. The following four operating modes are provided for the 8-bit timers.

- 8-bit interval timer mode (2 timers)
- 16-bit interval timer mode (1 timer)
- 8-bit programmable square wave pulse generation (PPG: variable duty with variable cycle) output mode (1 timer)
- 8-bit pulse width modulation (PWM: variable duty with constant cycle) output mode (1 timer)

Figure 3.7 (1) shows the block diagram of 8-bit timer (timer 0 and timer 1).

Each interval timer consists of an 8-bit up-counter, 8-bit comparator, and 8-bit timer register. Besides, one timer flip-flop (TFF1) is provided for pair of timer 0 and timer 1.

Among the input clock sources for the interval timers, the internal clocks of  $\phi T1$ ,  $\phi T4$ ,  $\phi T16$ , and  $\phi T256$  are obtained from the 9-bit prescaler shown in Figure 3.7 (2).

The operation modes and timer flip-flops of the 8-bit timer are controlled by three control registers TMOD, TFFCR, and TRUN.

Not Recommended for New Design

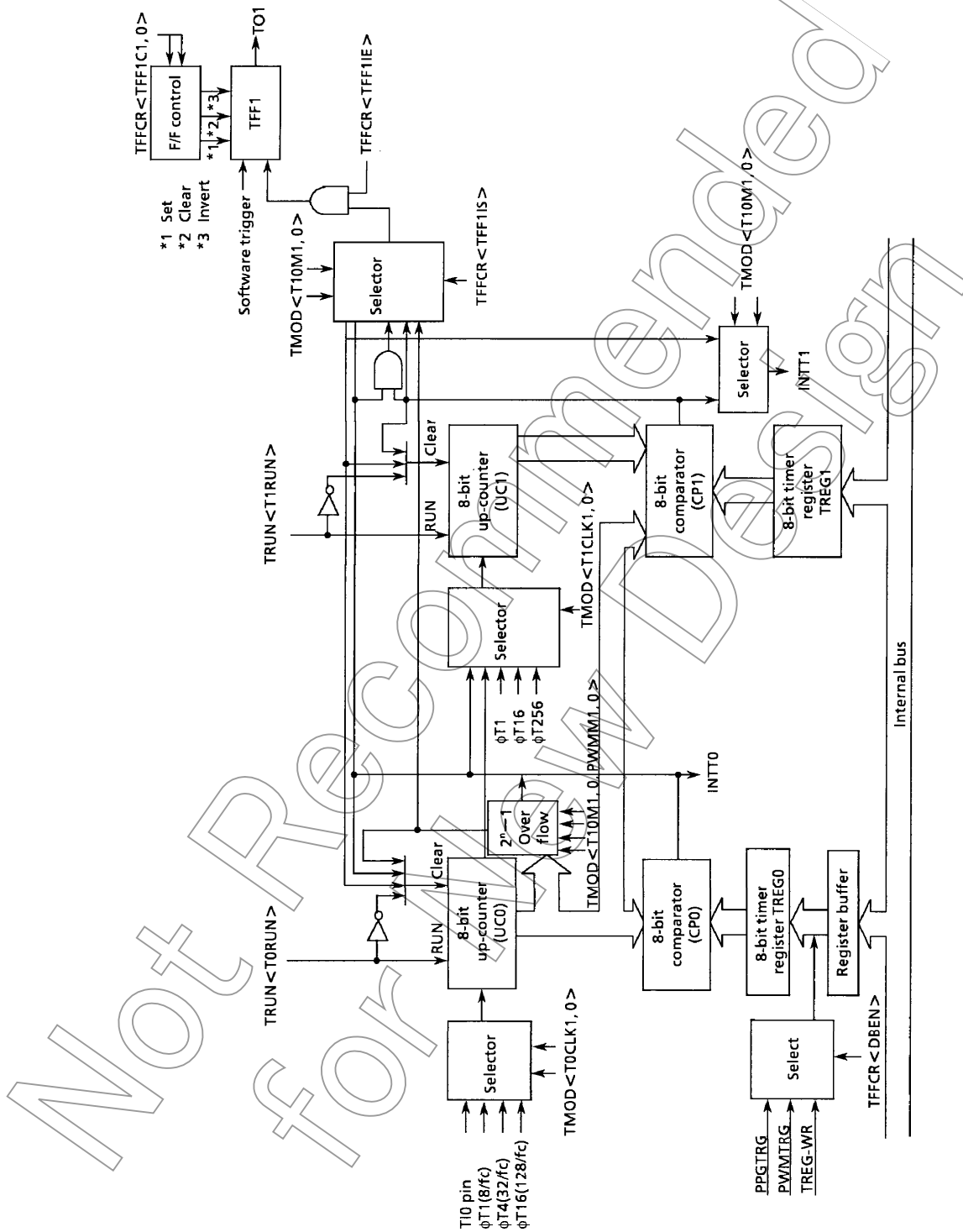

Figure 3.7 (1) Block Diagram of 8-bit Timers (Timers 0 and 1)

① Prescaler

This 9-bit prescaler generates the clock input to the 8-bit timers, 16-bit timer/event counters, and baud rate generators by further dividing the fundamental clock ( $f_c$ ) after it has been divided by 4 ( $f_c/4$ ).

Among them, 8-bit timer uses 4 types of clock:  $\phi T1$ ,  $\phi T4$ ,  $\phi T16$ , and  $\phi T256$ .

This prescaler can be run or stopped by the timer operation control register TRUN<PRRUN>. Counting starts when <PRRUN> is set to “1”, while the prescaler is cleared to zero and stops operation when <PRRUN> is set to “0”. Resetting clears <PRRUN> to “0”, which clears and stops the prescaler.

Input clock	Cycle	
	16 MHz	20 MHz
$\phi T1 (8/f_c)$	0.5 $\mu s$	0.4 $\mu s$
$\phi T4 (32/f_c)$	2.0 $\mu s$	1.6 $\mu s$
$\phi T16 (128/f_c)$	8.0 $\mu s$	6.4 $\mu s$
$\phi T256 (2048/f_c)$	128 $\mu s$	102 $\mu s$

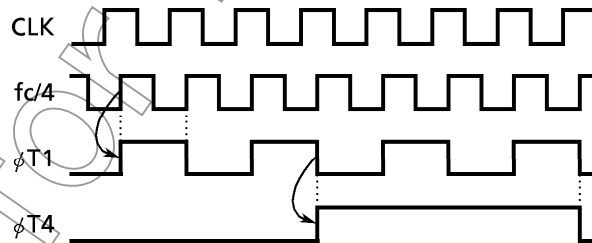
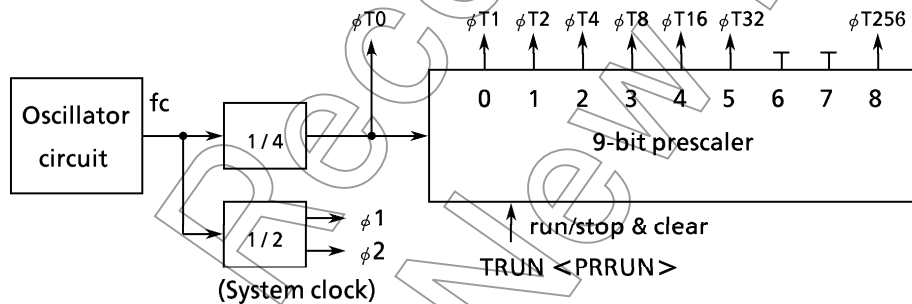

Figure 3.7 (2) Prescaler

## ② Up-counter

This is an 8-bit binary counter which counts up by the input clock pulse specified by TMOD.

The input clock of timer 0 is selected from the external clock from TI0 pin and the three internal clocks  $\phi$ T1 (8/fc),  $\phi$ T4 (32/fc), and  $\phi$ T16 (128/fc), according to the set value of TMOD register.

The input clock of timer 1 differs depending on the operation mode. When set to 16-bit timer mode, the overflow output of timer 0 is used as the input clock. When set to any other mode than 16-bit timer mode, the input clock is selected from the internal clocks  $\phi$ T1 (8/fc),  $\phi$ T16 (128/fc), and  $\phi$ T256 (2048/fc) as well as the comparator output (match detection signal) of timer 0 according to the set value of TMOD register.

Example: When TMOD<T10M1,0> = 01, the overflow output of timer 0 becomes the input clock of timer 1 (16-bit timer mode).

When TMOD<T10M1,0> = 00 and TMOD<T1CLK1,0> = 01,  $\phi$ T1 (8/fc) becomes the input of timer 1 (8bit timer mode).

Operation mode is also set by TMOD register. When reset, it is initialized to TMOD<T01M1, 0> = 00 whereby the up-counter is placed in the 8-bit timer mode.

The counting and stop & clear of up-counter can be controlled for each interval timer by the timer operation control register TRUN. When reset, all up-counters will be cleared to stop the timers.

## ③ Timer register

This is an 8-bit register for setting an interval time. When the set value of timer registers TREG0, TREG1, matches the value of up-counter, the comparator match detect signal becomes active. If the set value is 00H, this signal becomes active when the up-counter overflows.

Timer register TREG0 is of double buffer structure, each of which makes a pair with register buffer.

The timer flip-flop control register TFFCR<DBEN> bit controls whether the double buffer structure in the TREG0 should be enabled or disabled. It is disabled when <DBEN> = 0 and enabled when they are set to 1.

In the condition of double buffer enable state, the data is transferred from the register buffer to the timer register when the  $2^n - 1$  overflow occurs in PWM mode, or at the PPG cycle in PPG mode. Therefore, during timer mode, the double buffer can not be used.

When reset, it will be initialized to <DBEN> = 0 to disable the double buffer. To use the double buffer, write data in the timer register, set <DBEN> to 1, and

write the following data in the register buffer.

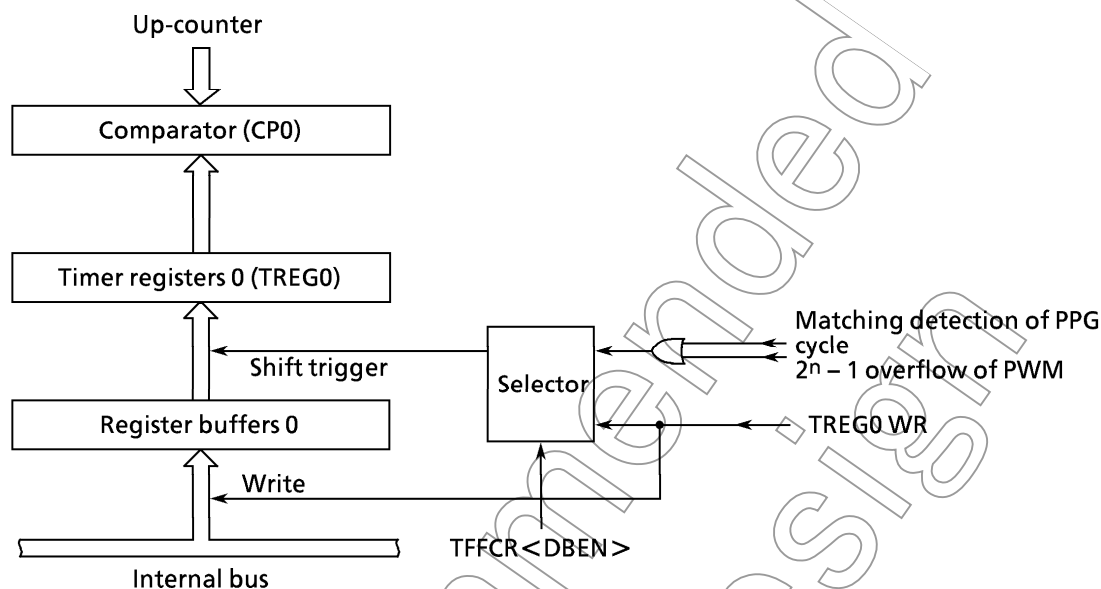

Figure 3.7 (3) Configuration of Timer Register 0

Note : Timer register and the register buffer are allocated to the same memory address. When  $\langle DBEN \rangle = 0$ , the same value is written in the register buffer as well as the timer register, while when  $\langle DBEN \rangle = 1$  only the register buffer is written.

The memory address of each timer register is as follows.

TREG0: 000022H

TREG1: 000023H

All the registers are write-only and cannot be read.

#### ④ Comparator

A comparator compares the value in the up-counter with the values to which the timer register is set. When they match, the up-counter is cleared to zero and an interrupt signal (INTT0, INTT1) is generated. If the timer flip-flop inversion is enabled, the timer flip-flop is inverted at the same time.

#### ⑤ Timer flip-flop (timer F/F : TFF1)

The status of the timer flip-flop is inverted by the match detect signal (comparator output) of each interval timer and the value can be output to the timer output pins TO1 (also used as P71).

A timer F/F is provided for a pair of timer 0 and timer 1 and is called TFF1. TFF1 is output to TO1 pin.



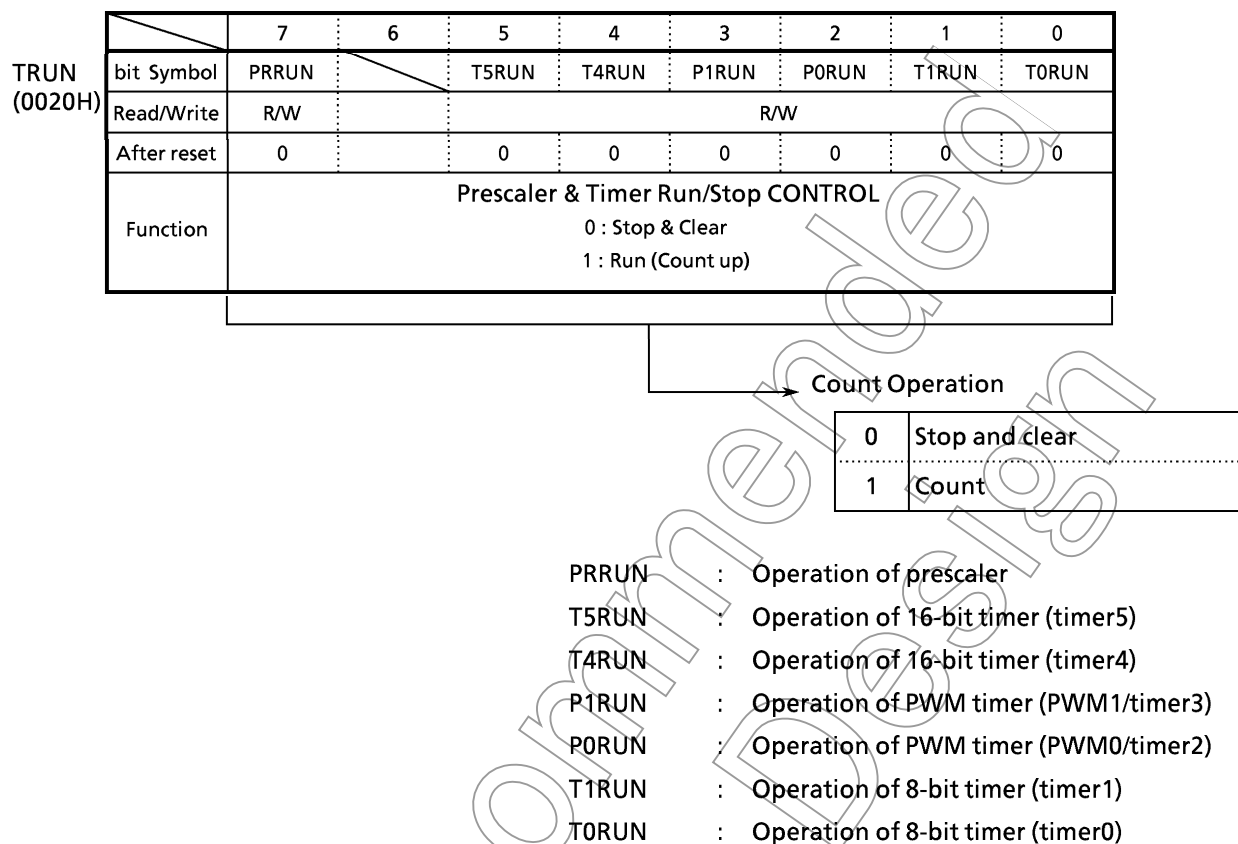

Figure 3.7 (4) Timer Operation Control Register (TRUN)

Not Recommended for New

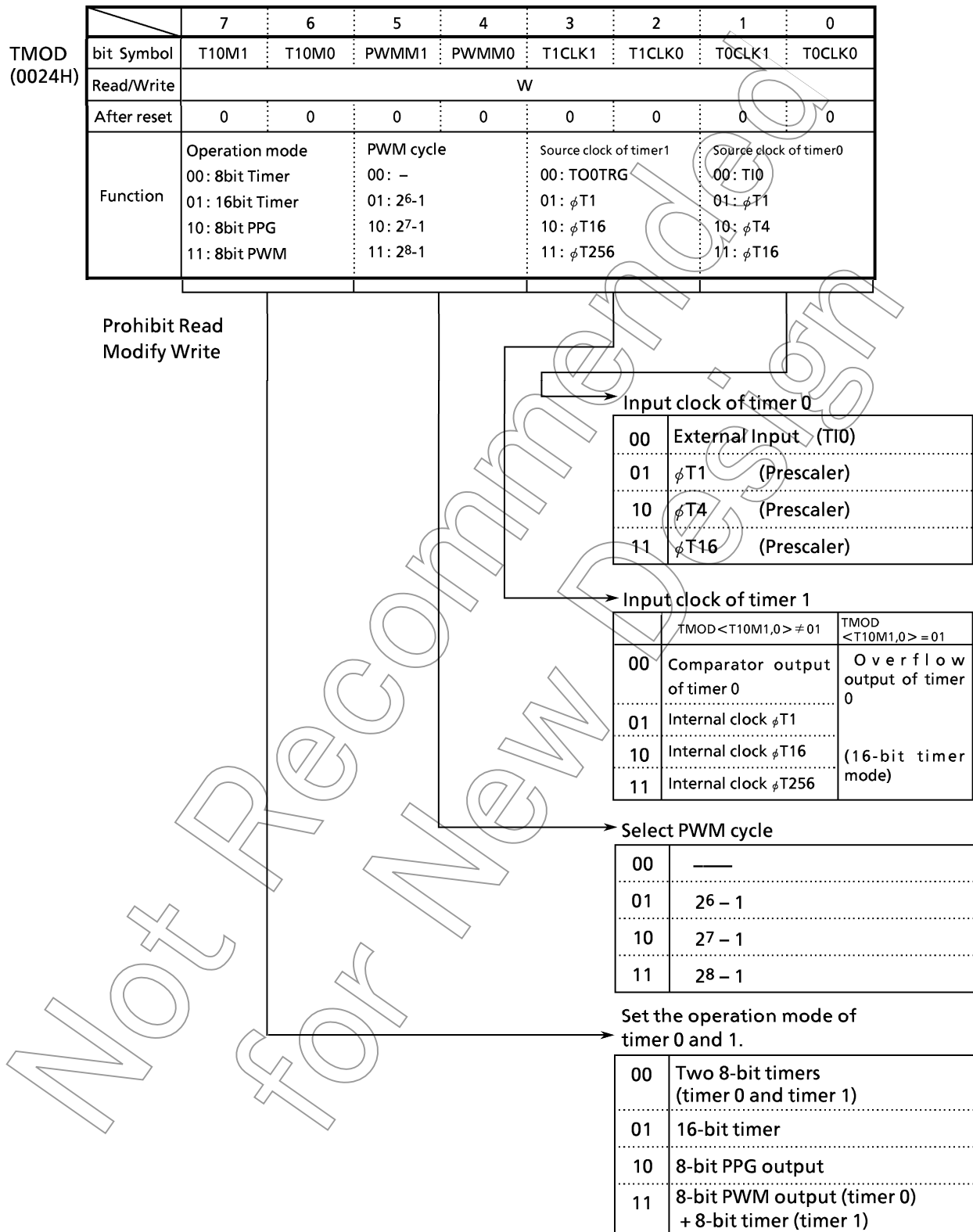

Figure 3.7 (5) Timer Mode control Register (TMOD)

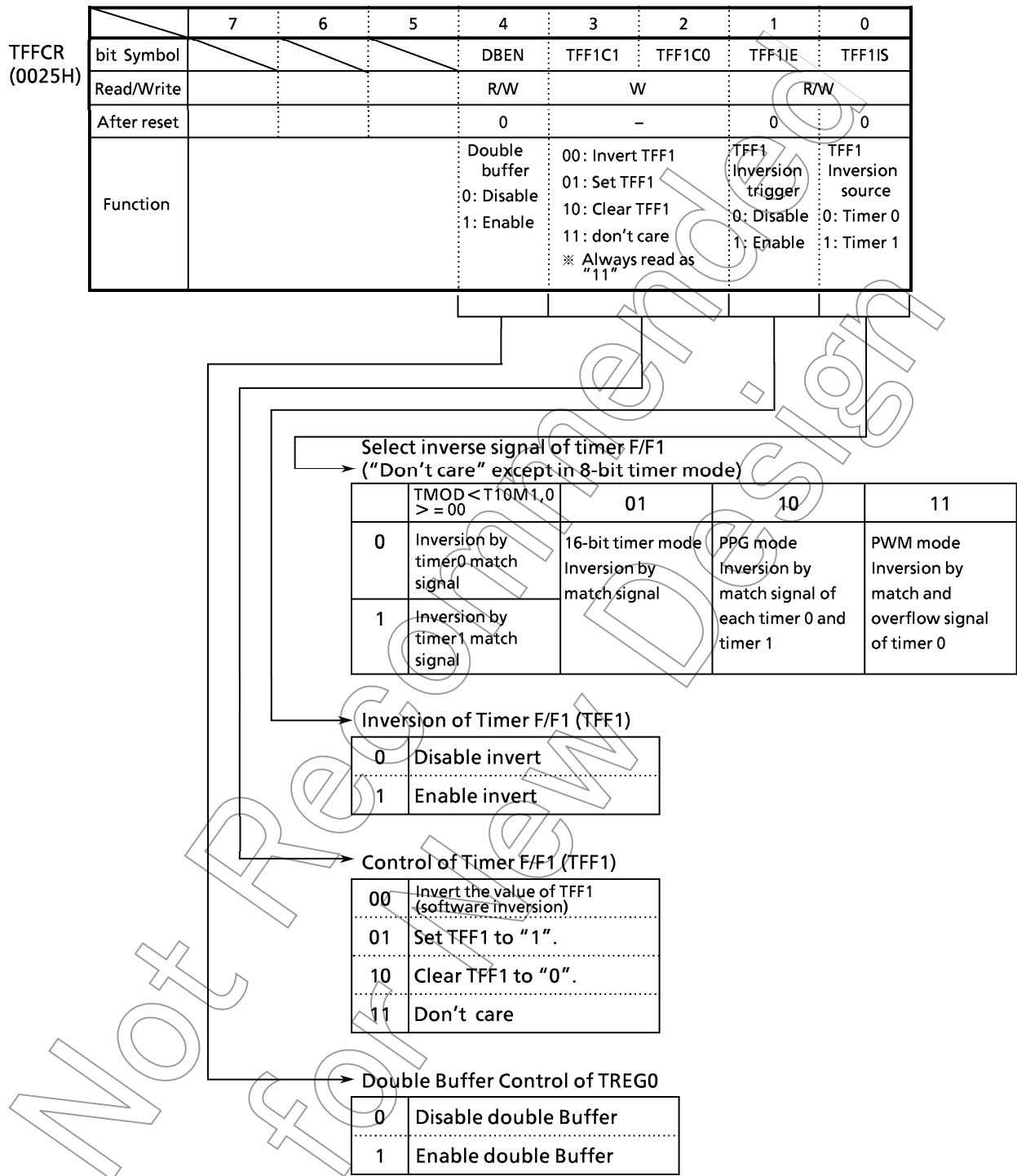

Figure 3.7 (6) Timer Flip-flop Control Register (TFFCR)

The operation of 8-bit timers will be described below:

(1) 8-bit timer mode

Two interval timers 0, 1, can be used independently as 8-bit interval timer. All interval timers operate in the same manner, and thus only the operation of timer 1 will be explained below.

① Generating interrupts in a fixed cycle

To generate timer 1 interrupt at constant intervals using timer 1 (INTT1), first stop timer 1 then set the operation mode, input clock, and a cycle to TMOD and TREG1 register, respectively. Then, enable interrupt INTT1 and start the counting of timer 1.

Example : To generate timer 1 interrupt every 40 microseconds at  $f_c = 16$  MHz, set each register in the following manner.

	MSB		LSB							
	7	6	5	4	3	2	1	0		
TRUN	←	-	X	-	-	-	-	0	-	Stop timer 1, and clear it to "0".
TMOD	←	0	0	X	X	0	1	-	-	Set the 8-bit timer mode, and select $\phi T1$ ( $0.5 \mu s$ @ $f_c = 16$ MHz) as the input clock.
TREG1	←	0	1	0	1	0	0	0	0	Set the timer register at $40 \mu s$ $\phi T1 = 50H$ .
INTET10	←	1	1	0	1	-	-	-	-	Enable INTT1, and set it to "Level 5".
TRUN	←	1	X	-	-	-	-	1	-	Start timer 1 counting.

Note : X: Don't care    -, no change

Use the following table for selecting the input clock.

Table 3.7 (1) 8-Bit Timer Interrupt Cycle and Input Clock

Input clock	Interrupt cycle (at $f_c = 16$ MHz)	Resolution	Interrupt cycle (at $f_c = 20$ MHz)	Resolution
$\phi T1$ (8/ $f_c$ )	$0.5 \mu s$ to $128 \mu s$	$0.5 \mu s$	$0.4 \mu s$ to $102.4 \mu s$	$0.4 \mu s$
$\phi T4$ (32/ $f_c$ )	$2 \mu s$ to $512 \mu s$	$2 \mu s$	$1.6 \mu s$ to $409.6 \mu s$	$1.6 \mu s$
$\phi T16$ (128/ $f_c$ )	$8 \mu s$ to $2.048$ ms	$8 \mu s$	$6.4 \mu s$ to $1.638$ ms	$6.4 \mu s$
$\phi T256$ (2048/ $f_c$ )	$128 \mu s$ to $32.708$ ms	$128 \mu s$	$102.4 \mu s$ to $2.621$ ms	$102.4 \mu s$

Note : The input clock of timer 0 and timer 1 are different from as follows.

Timer 0 : TI0 input,  $\phi T1$ ,  $\phi T4$ ,  $\phi T16$

Timer 1 : Match Output of Timer 0,  $\phi T1$ ,  $\phi T16$ ,  $\phi T256$

② Generating a 50% duty square wave pulse

The timer flip-flop (TFF1) is inverted at constant intervals, and its status is output to timer output pin (TO1).

Example : To output a 3.0  $\mu$ s square wave pulse from TO1 pin at  $f_c = 16$  MHz, set each register in the following procedures. Either timer 0 or timer 1 may be used, but this example uses timer 1.

7 6 5 4 3 2 1 0		
TRUN	← - X - - - - 0 -	Stop timer 1, and clear it to "0".
TMOD	← 0 0 X X 0 1 - -	Set the 8-bit timer mode, and select $\phi$ T1 (0.5 $\mu$ s @ $f_c = 16$ MHz) as the input clock.
TREG1	← 0 0 0 0 0 0 1 1	Set the timer register at $3.0 \mu\text{s} \div \phi\text{T1} \div 2 = 3$ .
TFFCR	← - - - - 1 0 1 1	Clear TFF1 to "0", and set to invert by the match detect signal from timer 1.
P7CR	← X X X X - - 1 -	} Select P71 as TO1 pin.
P7FC	← X X X X - - 1 X	
TRUN	← 1 X - - - - 1 -	Start timer 1 counting.

Note : X ; Don't care      - ; no change

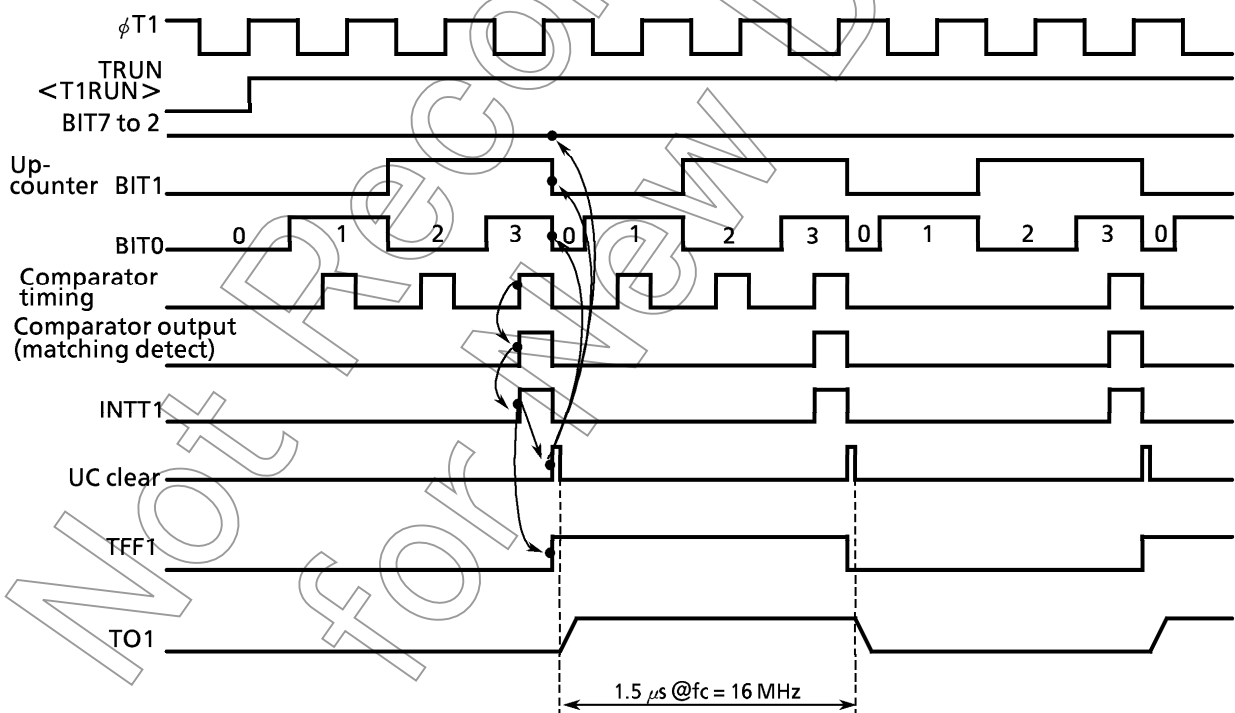

Figure 3.7 (7) Square Wave (50% Duty) Output Timing Chart

③ Making timer 1 count up by match signal from timer 0 comparator

Set the 8-bit timer mode, and set the comparator output of timer 0 as the input clock to timer 1.

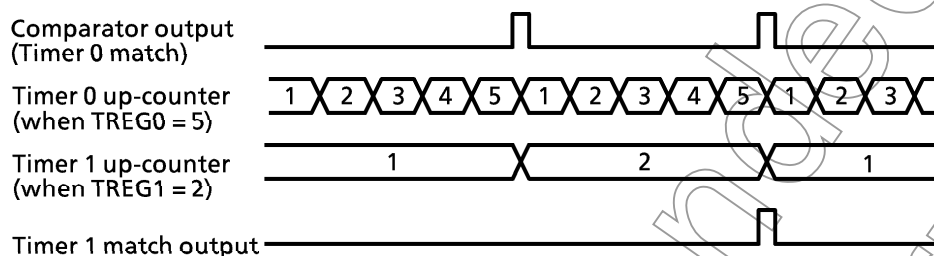

Figure 3.7 (8) Timer 1 count up by timer 0

④ Output inversion with software

The value of timer flip-flop (TFF1) can be inverted, independent of timer operation.

Writing “00” into TFFCR <TFF1C1, 0> (memory address : 000025h of bit 3 and bit 2) inverts the value of TFF1.

⑤ Initial setting of timer flip-flop (TFF1)

The value of TFF1 can be initialized to “0” or “1”, independent of timer operation.

For example, write “10” in TFFCR <TFF1C1,0> to clear TFF1 to “0”, while write “01” in TFFCR <TFF1C1,0> to set TFF1 to “1”.

Note: The value of timer register cannot be read.

(2) 16-bit timer mode

A 16-bit interval timer is configured by using the pair of timer 0 and timer 1.

To make a 16-bit interval timer by cascade connecting timer 0 and timer 1, set timer 0/timer 1 mode register TMOD <T10M1,0> to “0, 1”.

When set in 16-bit timer mode, the overflow output of timer 0 will become the input clock of timer 1, regardless of the set value of TMOD <T1CLK1, 0>. Table 3.7 (2) shows the relation between the cycle of timer (interrupt) and the selection of input clock.

Table 3.7 (2) 16-Bit Timer (Interrupt) and Input Clock

Input clock	Interrupt cycle (fc = 16 MHz)	Resolution	Interrupt cycle (fc = 20 MHz)	Resolution
$\phi$ T1 (8/fc)	0.5 $\mu$ s to 32.786 ms	0.5 $\mu$ s	0.4 $\mu$ s to 26.214 ms	0.4 $\mu$ s
$\phi$ T4 (32/fc)	2 $\mu$ s to 131.072 ms	2 $\mu$ s	1.6 $\mu$ s to 104.857 ms	1.6 $\mu$ s
$\phi$ T16 (128/fc)	8 $\mu$ s to 524.288 ms	8 $\mu$ s	6.4 $\mu$ s to 419.430 ms	6.4 $\mu$ s

The lower 8 bits of the timer (interrupt) cycle are set by the timer register TREG0, and the upper 8 bits are set by TREG1. Note that TREG0 always must be set first. (Writing data into TREG0 disables the comparator temporarily, and the comparator is restarted by writing data into TREG1.)

Setting example: To generate an interrupt INTT1 every 0.5 seconds at  $f_c = 16$  MHz, set the following values for timer registers TREG0 and TREG1.

When counting with input clock of  $\phi T16$  ( $8 \mu\text{s}$  @ 16 MHz)

$$0.5 \text{ s} \div 8 \mu\text{s} = 62500 = \text{F424H}$$

Therefore, set TREG1 = F4H and TREG0 = 24H, respectively.

The comparator match signal is output from timer 0 each time the up-counter UC0 matches TREG0, where the up-counter UC0 is not be cleared. And the interrupt INTO is not generated.

With the timer 1 comparator, the match detect signal is output at each comparator timing when up-counter UC1 and TREG1 values match. When the match detect signal is output simultaneously from both comparators of timer 0 and timer 1, the up-counters UC0 and UC1 are cleared to "0", and only the interrupt INTT1 is generated. If inversion is enabled, the value of the timer flip-flop TFF1 is inverted.

Example : When TREG1 = 04H and TREG0 = 80H

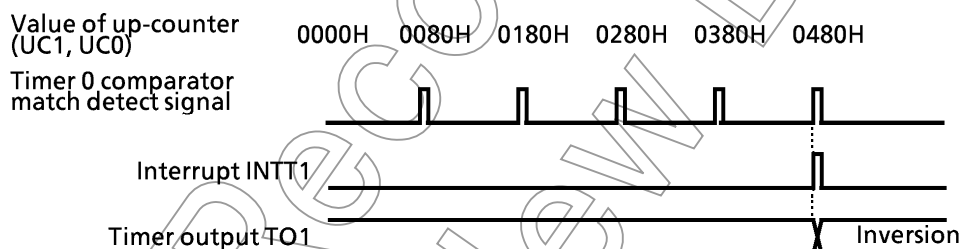

Figure 3.7 (9) Output timer by 16-bit timer mode

### (3) 8-bit PPG (Programmable Pulse Generation) Output mode

Square wave pulse can be generated at any frequency and duty by timer 0 and timer 1. The output pulse may be either low-active or high-active. In this mode, timer 1 cannot be used.

Timer 0 outputs pulse to TO1 pin (also used as P70).

In this mode, a programmable square wave is generated by inverting timer output each time the 8-bit up-counter (UC0) matches the timer registers TREG0 and TREG1.

However, it is required that the set value of TREG0 is smaller than that of TREG1.

Though the up-counter (UC1) of timer 1 is not used in this mode, UC1 should be set for counting by setting TRUN < T1RUN > to 1.

Figure 3.7 (11) shows the block diagram for this mode.

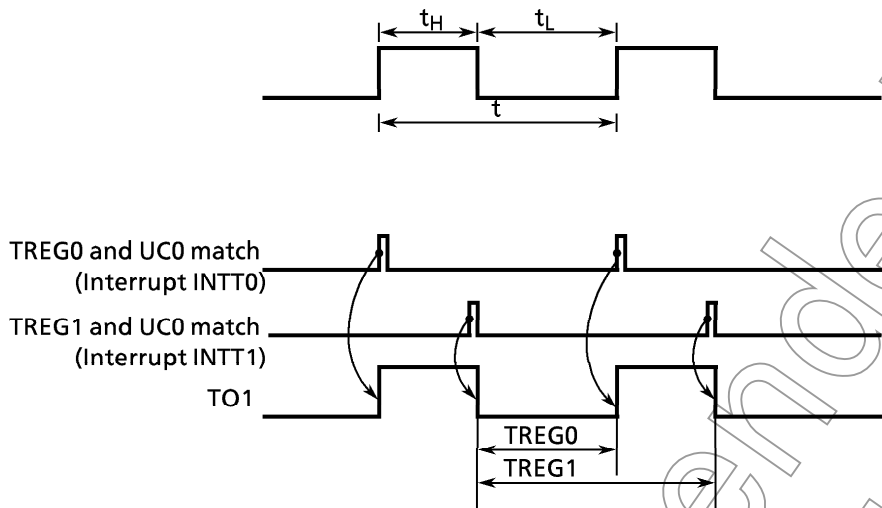

Figure 3.7 (10) 8bit PPG output waveforms

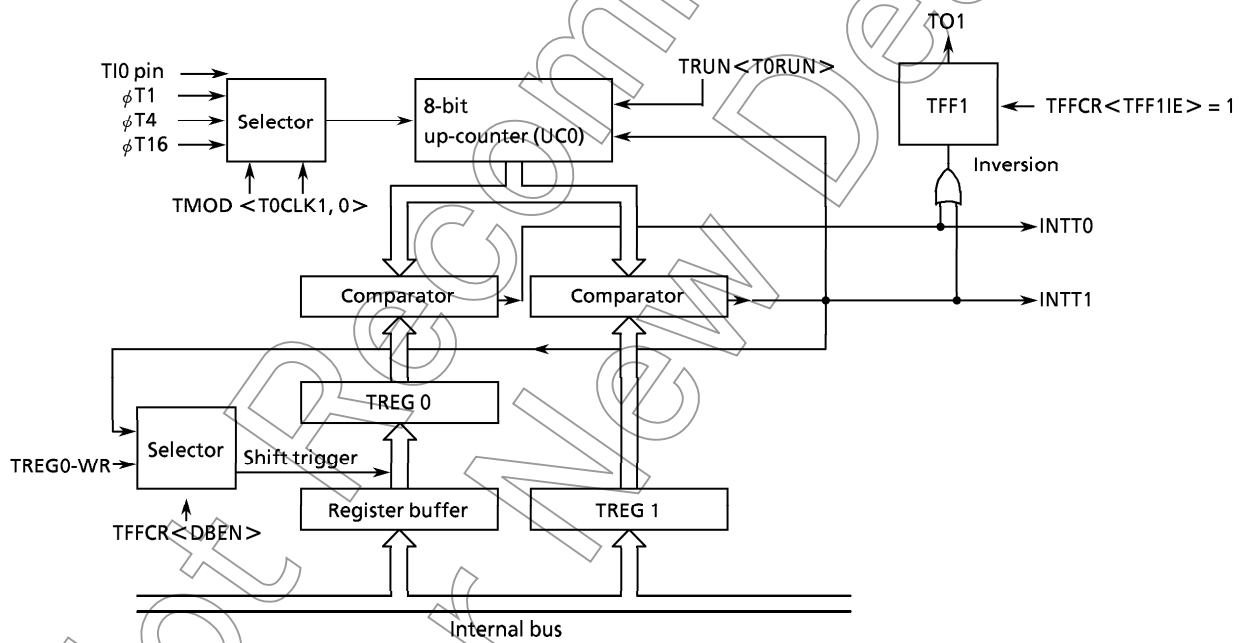

Figure 3.7 (11) Block Diagram of 8-Bit PPG Output Mode



When the double buffer of TREG0 is enabled in this mode, the value of register buffer will be shifted in TREG0 each time TREG1 matches UC0.

Use of the double buffer makes easy the handling of low duty waves (when duty is varied).

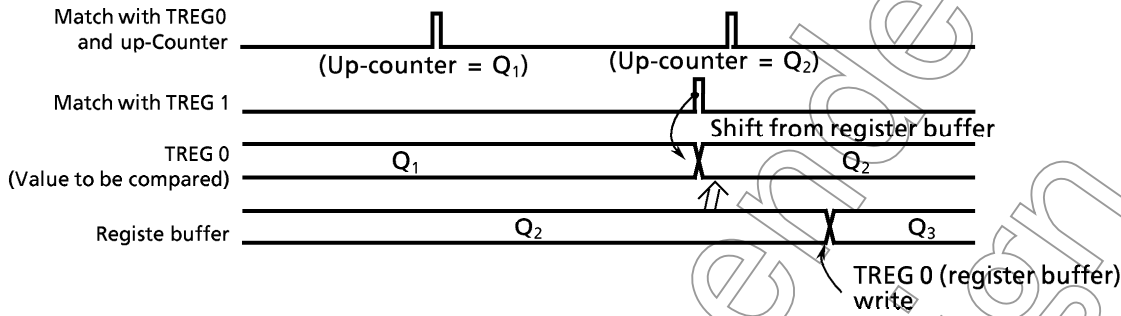

Figure 3.7 (12) Operation of Register buffer

Example : Generating 1/4 duty 50 kHz pulse (@ fc = 16 MHz)



- Calculate the value to be set for timer register.  
 To obtain the frequency 50 kHz, the pulse cycle  $t$  should be :  $t = 1/50 \text{ kHz} = 20 \mu\text{s}$ .  
 Given  $\phi T1 = 0.5 \mu\text{s} (@ 16 \text{ Hz})$ ,  
 $20 \mu\text{s} \div 0.5 \mu\text{s} = 40$   
 Consequently, to set the timer register 1 (TREG1) to  $TREG1 = 40 = 28\text{H}$   
 and then duty to 1/4,  $t \times 1/4 = 20 \mu\text{s} \times 1/4 = 5 \mu\text{s}$   
 $5 \mu\text{s} \div 0.5 \mu\text{s} = 10$   
 Therefore, set timer register 0 (TREG0) to  $TREG0 = 10 = 0\text{AH}$ .

	7	6	5	4	3	2	1	0		
TRUN	←	-	X	-	-	-	0	0	Stop timer 0, and clear it to "0".	
TMOD	←	1	0	X	X	X	X	0	1	Set the 8-bit PPG mode, and select $\phi T1$ as input clock.
TREG0	←	0	0	0	0	1	0	1	0	Write "0AH".
TREG1	←	0	0	1	0	1	0	0	0	Write "28H".
TFFCR	←	-	-	-	X	0	1	1	X	Sets TFF1 and enable the inversion.
										Writing "10" provides negative logic pulse.
P7CR	←	X	X	X	X	-	-	1	-	} Set P71 as the TO1 pin.
P7FC	←	X	X	X	X	-	-	1	X	
TRUN	←	1	X	-	-	-	-	1	1	Start timer 0 and timer 1 counting.

Note : X ; Don't care - ; No change

## (4) 8-bit PWM Output mode

This mode is valid only for timer 0. In this mode, maximum 8-bit resolution of PWM pulse can be output.

PWM pulse is output to TO1 pin (also used as P71) when using timer 0. Timer 1 can also be used as 8-bit timer.

Timer output is inverted when up-counter (UC0) matches the set value of timer register TREG0 or when  $2^n - 1$  ( $n=6, 7, \text{ or } 8$ ; specified by T01MOD<PWM01,0>) counter overflow occurs. Up-counter UC0 is cleared when  $2^n - 1$  counter overflow occurs. For example, when  $n=6$ , 6-bit PWM will be outputted, while when  $n=7$ , 7-bit PWM will be outputted.

To use this PWM mode, the following conditions must be satisfied.

(Set value of timer register) < (Set value of  $2^n - 1$  counter overflow)

(Set value of timer register)  $\neq 0$

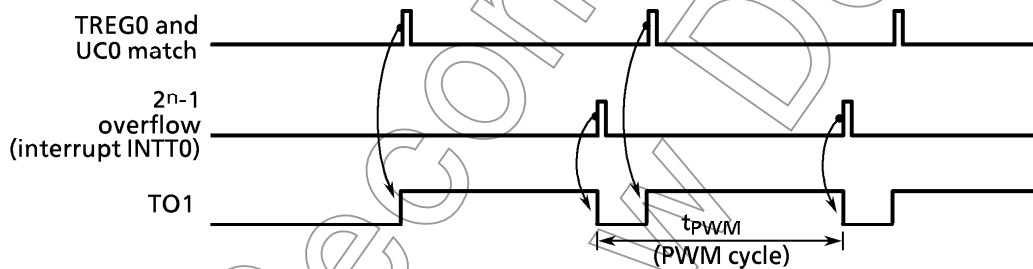

Figure 3.7(13) 8-bit PWM waveforms

Figure 3.7 (14) shows the block diagram of this mode.

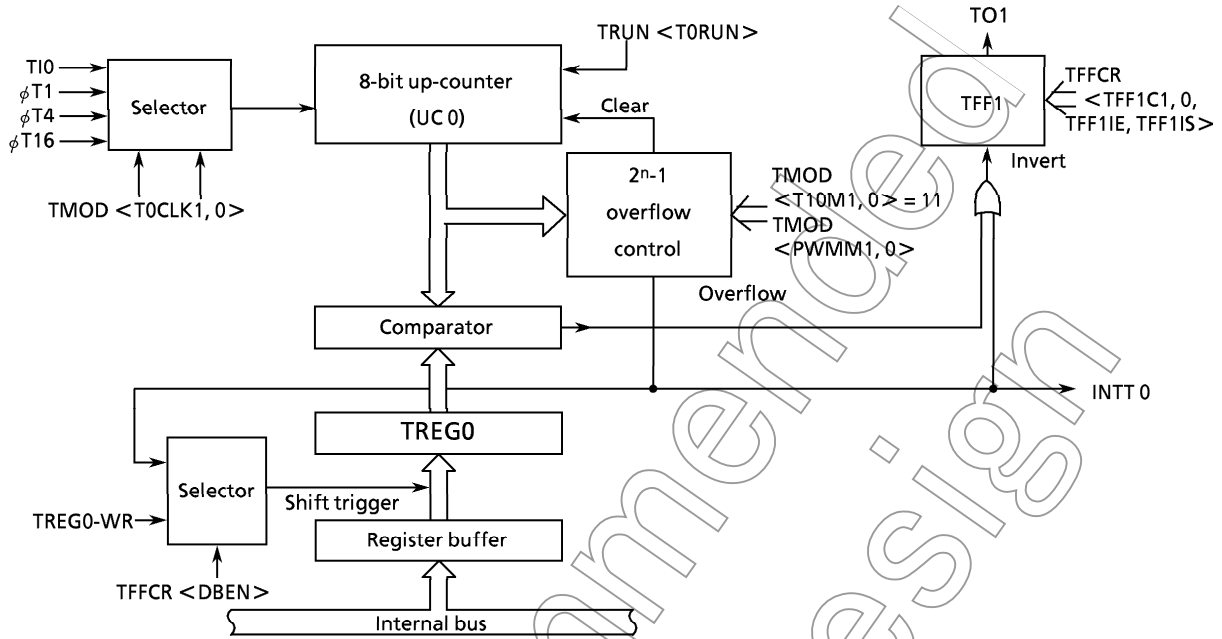

Figure 3.7 (14) Block Diagram of 8-Bit PWM Mode

In this mode, the value of register buffer will be shifted in TREG0 if  $2^n - 1$  overflow is detected when the double buffer of TREG0 is enabled.

Use of the double buffer makes easy the handling of small duty waves.

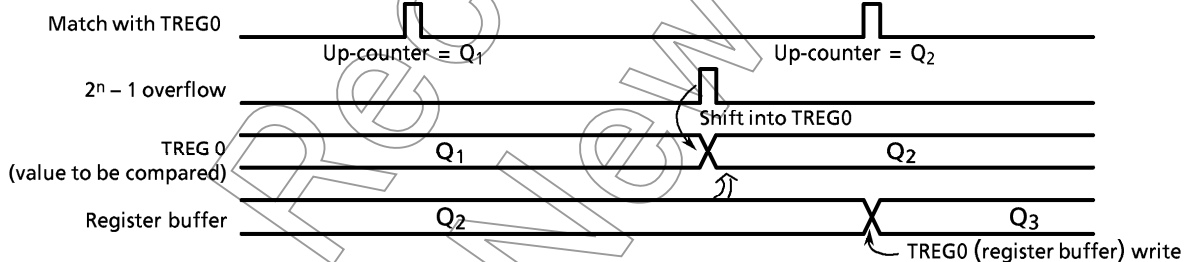
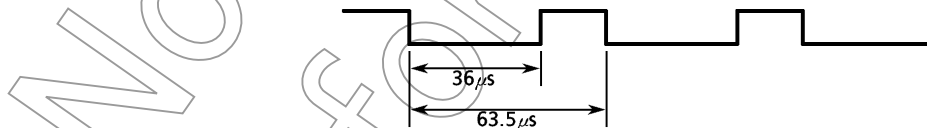

Figure 3.7 (15) Operation of Register buffer

Example : To output the following PWM waves to TO1 pin at  $f_c = 16$  MHz.



To realize  $63.5 \mu s$  of PWM cycle by  $\phi T1 = 0.5 \mu s$  (@ $f_c = 16$  MHz),

$$63.5 \mu s \div 0.5 \mu s = 127 = 2^7 - 1$$

Consequently, n should be set to 7.

As the period of low level is  $36 \mu s$ , for  $\phi T1 = 0.5 \mu s$ ,

set the following value for TREG0.

$$36 \mu s \div 0.5 \mu s = 72 = 48H$$

MSB	LSB	
7 6 5 4 3 2 1 0		
TRUN ← - X - - - - 0		Stop timer 0, and clear it to "0".
TMOD ← 1 1 1 0 - - 0 1		Set 8-bit PWM mode (cycle: 2 <sup>7</sup> - 1) and select φT1 as the input clock.
TREG0 ← 0 1 0 0 1 0 0 0		Writes "48H".
TFFCR ← X X X X 1 0 1 X		Clears TFF1, enable the inversion.
P7CR ← X X X X - - 1 -	}	Set P71 as the TO1 pin.
P7FC ← X X X X - - 1 X		
TRUN ← 1 X - - - - - 1		Start timer 0 counting.

Note : X ; Don't care - ; No change

Table 3.7 (3) PWM Cycle and the Setting of 2<sup>n</sup> - 1 Counter

	PWM cycle (@ fc = 16 MHz)			PWM cycle (@ fc = 20 MHz)		
	φT1	φT4	φT16	φT1	φT4	φT16
2 <sup>6</sup> -1	31.5 μs (31.7 kHz)	126 μs (7.9 kHz)	0.50 ms (1.9 kHz)	25.2 μs (39.0 kHz)	100 μs (10.0 kHz)	0.40 ms (2.4 kHz)
2 <sup>7</sup> -1	63.5 μs (15.7 kHz)	254 μs (3.9 kHz)	1.01 ms (0.98 kHz)	50.8 μs (19.7 kHz)	203 μs (4.9 kHz)	0.81 ms (1.2 kHz)
2 <sup>8</sup> -1	127 μs (7.8 kHz)	510 μs (1.9 kHz)	2.04 ms (0.49 kHz)	102 μs (9.80 kHz)	408 μs (2.4 kHz)	1.63 ms (0.61 kHz)

(5) Table 3.7 (4) shows the list of 8-bit timer modes.

Table 3.7 (4) Timer Mode Setting Registers

Register name	TMOD				TFFCR
Name of function in	T10M	PWMM	T1CLK	T0CLK	TFF1IS
Function	Timer mode	PWM0 cycle	Upper timer input clock	Lower timer input clock	Timer F/F invert signal select
16-bit timer mode	01	-	-	External clock, φT1, φT4, φT16 (00, 01, 10, 11)	-
8-bit timer × 2 channels	00	-	Lower timer match: φT1, 16, 256 (00, 01, 10, 11)	External clock, φT1, φT4, φT16 (00, 01, 10, 11)	0: Lower timer output 1: Upper timer output
8-bit PPG × 1 channel	10	-	-	External clock, φT1, φT4, φT16 (00, 01, 10, 11)	-
8-bit PWM × 1 channel	11	2 <sup>6</sup> -1, 2 <sup>7</sup> -1, 2 <sup>8</sup> -1 (01, 10, 11)	-	External clock, φT1, φT4, φT16 (00, 01, 10, 11)	-
8-bit timer × 1 channel	11	-	φT1, φT16, φT256 (01, 10, 11)	-	Output disabled

Note : - ; Don't care

### 3.8 8-bit PWM Timer

The TMP96C141B has two built-in 8-bit PWM timers (timers 2 and 3). They have two operating modes.

- 8-bit PWM (pulse width modulation: variable duty at fixed interval) output mode
- 8-bit interval timer mode

Figure 3.8 (1) is a block diagram of 8-bit PWM timer (timers 2 and 3).

PWM timers consist of an 8-bit up-counter, 8-bit comparator, and 8-bit timer register. Two timer flip-flops (TFF2 for timer 2 and TFF3 for timer 3) are provided.

Input clocks  $\phi P1$ ,  $\phi P4$ , and  $\phi P16$  for the PWM timers can be obtained using the built-in prescaler.

PWM timer operating mode and timer flip-flops are controlled by four control registers (P0MOD, P1MOD, PFFCR, and TRUN).

Not Recommended  
for New Design



## ① Prescaler

Generates input clocks dedicated to PWM timers by further dividing the fundamental clock ( $f_c$ ) after it has been divided by 2 ( $f_c/2$ ). Since the register used to control the prescaler is the same as the one for other timers, the prescaler cannot be operated independently.

The PWM timer uses three input clocks:  $\phi/P1$ ,  $\phi/P4$ , and  $\phi/P16$ .

Like the 9-bit prescaler described in the 8-bit timer section, this prescaler can be counted/stopped using bit 7 <PRRUN> of the timer operation control register TRUN. Setting <PRRUN> to 1 starts counting; setting it to 0 zero-clears and stops counting. Resetting clears <PRRUN> to 0, which clears and stops the prescaler.

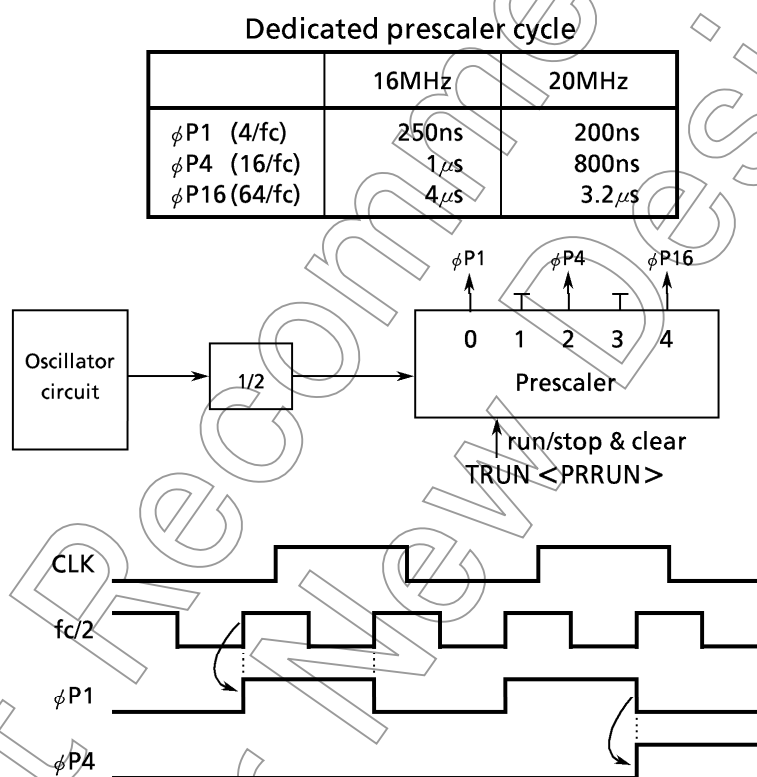

Figure3.8 (2) Prescaler

## ② Up-counter

An 8-bit binary counter which counts up using the input clock specified by PWM mode register (P0MOD or P1MOD).

The input clock for the PWM0/PWM1 is selected from the internal clocks  $\phi P1$ ,  $\phi P4$ , and  $\phi P16$  (PWM dedicated prescaler output) depending on the value set in the P0MOD/P1MOD register.

Operating mode is also set by P0MOD and P1MOD registers. At reset, they are initialized to P0MOD<PWM0M> = 0 and P1MOD<PWM1M> = 0, thus, the up-counter is in PWM mode. In PWM mode, the up-counter is cleared when a  $2^n-1$  overflow occurs; in timer mode, the up-counter is cleared at compare and match.

Count/stop & clear of the up-counter can be controlled for each PWM timer using the timer operation control register TRUN. Resetting clears all up-counters and stops timers.

### ③ Timer registers

Two 8-bit registers used for setting an interval time. When the value set in the timer registers (TREG2 and 3) matches the value in the up-counter, the match detect signal of the comparator becomes active.

Timer registers TREG2 and TREG3 are each paired with register buffer to make a double buffer structure.

TREG2 and TREG3 are controlled double buffer enable/disable by P0MOD <DB2EN> and P1MOD <DB3EN> : disabled when <DB2EN> / <DB3EN> = 0, enabled when <DB2EN> / <DB3EN> = 1.

Data is transferred from register buffer to timer register when a  $2^n-1$  overflow occurs in PWM mode, or when compare and match occurs in 8-bit timer mode. That is, with a PWM timer, the timer mode can be operated in double buffer enable state, unlike timer mode for timers 0 and 1.

At reset, <DB2EN>/<DB3EN> is initialized to 0 to disable double buffer. To use double buffer, write the data in the timer register at first, then set <DB2EN> / <DB3EN> to 1, and write the following data in the register buffer.

Not Ready for New



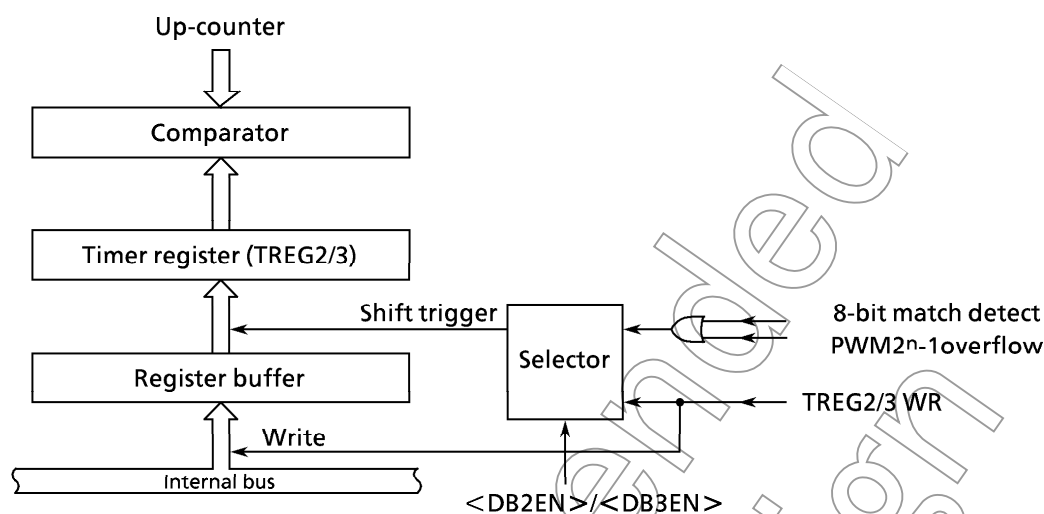

Figure3.8 (3) Structure of Timer Registers 2 and 3

Note : The timer register and register buffer are allocated to the same memory address. When  $\langle \text{DB2EN} \rangle / \langle \text{DB3EN} \rangle = 0$ , the same value is written to both register buffer and timer register. When  $\langle \text{DB2EN} \rangle / \langle \text{DB3EN} \rangle = 1$ , the value is written to the register buffer only.

Memory addresses of the timer registers are as follows:

TREG2 : 000026H

TREG3 : 000027H

Both timer registers are write only; however, register buffer values can be read when reading the above addresses.

#### ④ Comparator

Compares the value in the up-counter with the value in the timer register (TREG2/TREG3). When they match, the comparator outputs the match detect signal. A timer interrupt (INTT2/INTT3) is generated at compare and match if the interrupt select bit  $\langle \text{PWM0INT} \rangle / \langle \text{PWM1INT} \rangle$  of the mode register (P0MOD/P1MOD) is set to 1. In timer mode, the comparator clears the up-counter to 0 at compare and match. It also inverts the value of the timer flip-flop if timer flip-flop invert is enabled.

#### ⑤ Timer flip-flop

The value of the timer flip-flop is inverted by the match detect signal (comparator output) of each interval timer or  $2^n - 1$  overflow. The value can be output to the timer output pin TO2/TO3 (also used as P72/P73).

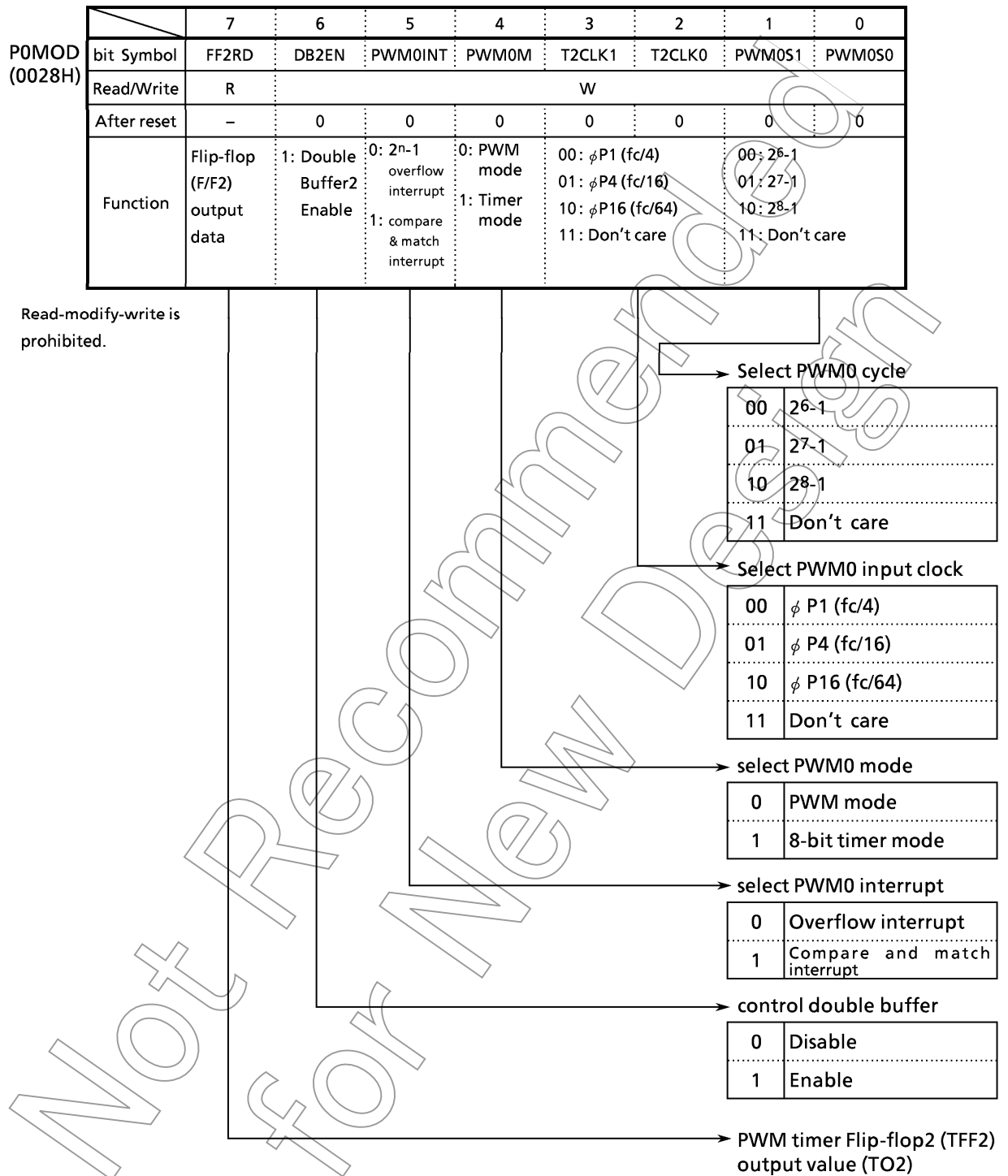

Figure3.8 (4) 8-bit PWM0 mode control register

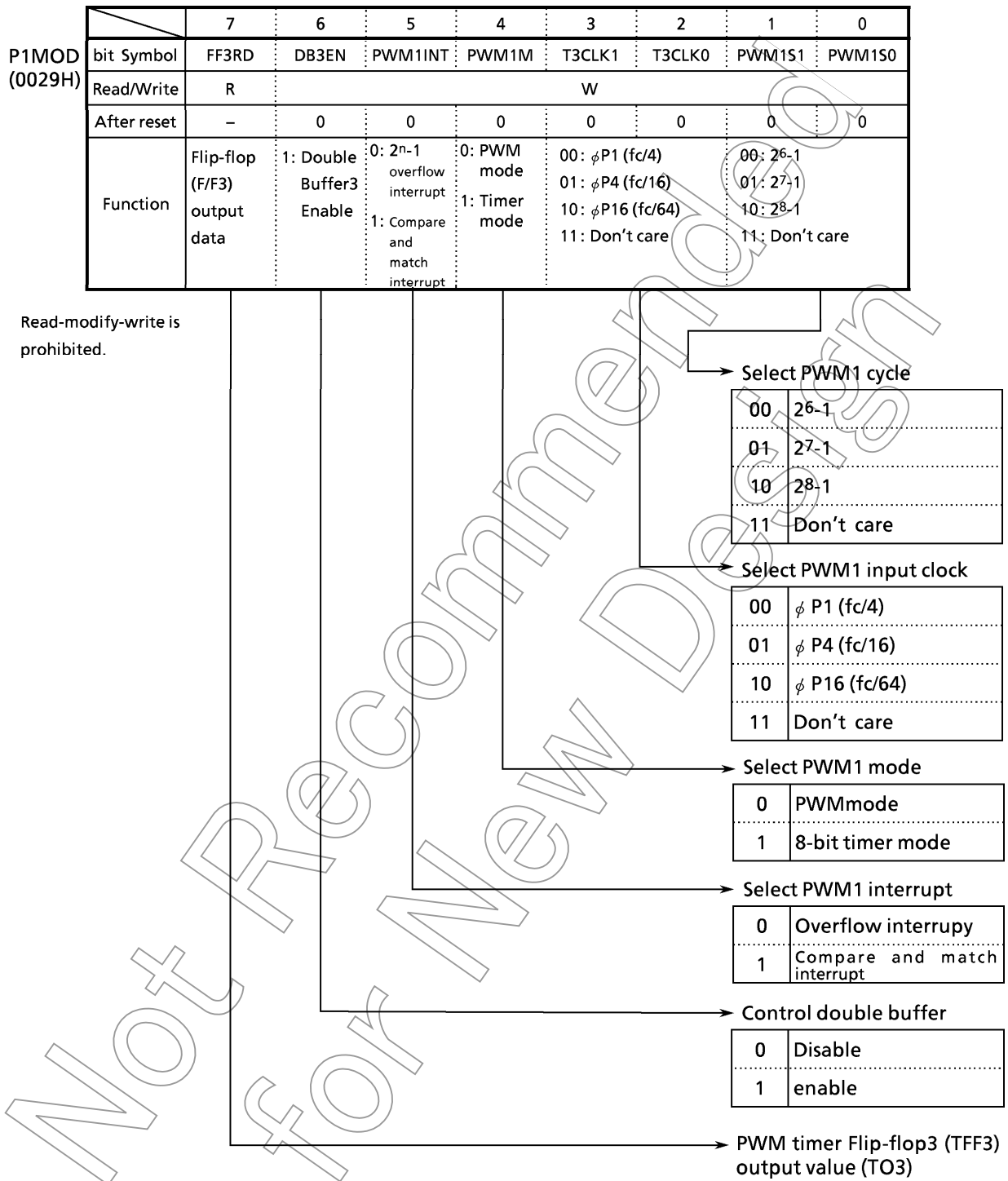

Figure 3.8 (5) 8-bit PWM1 mode control register

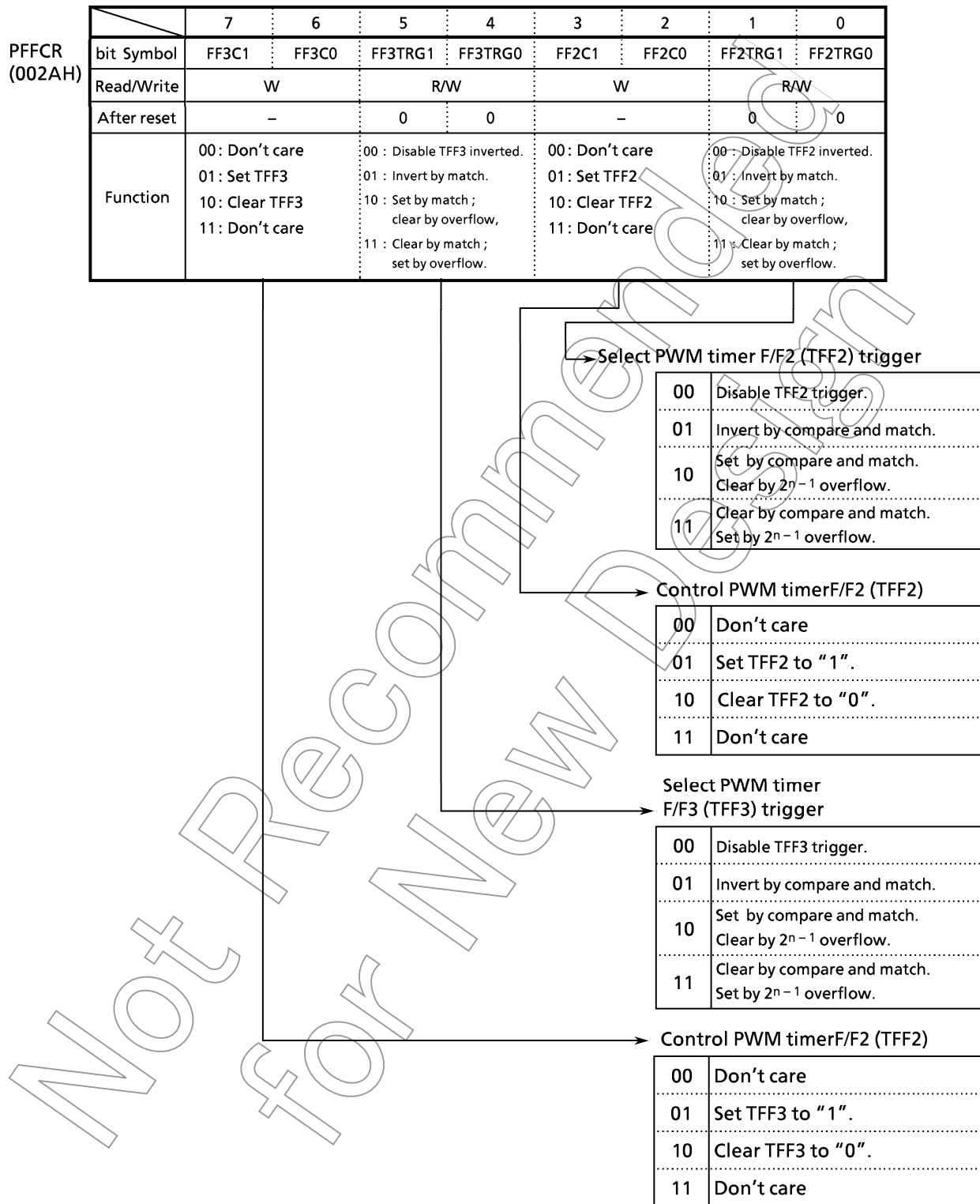

Figure 3.8 (6) 8-bit PWM F/F control register

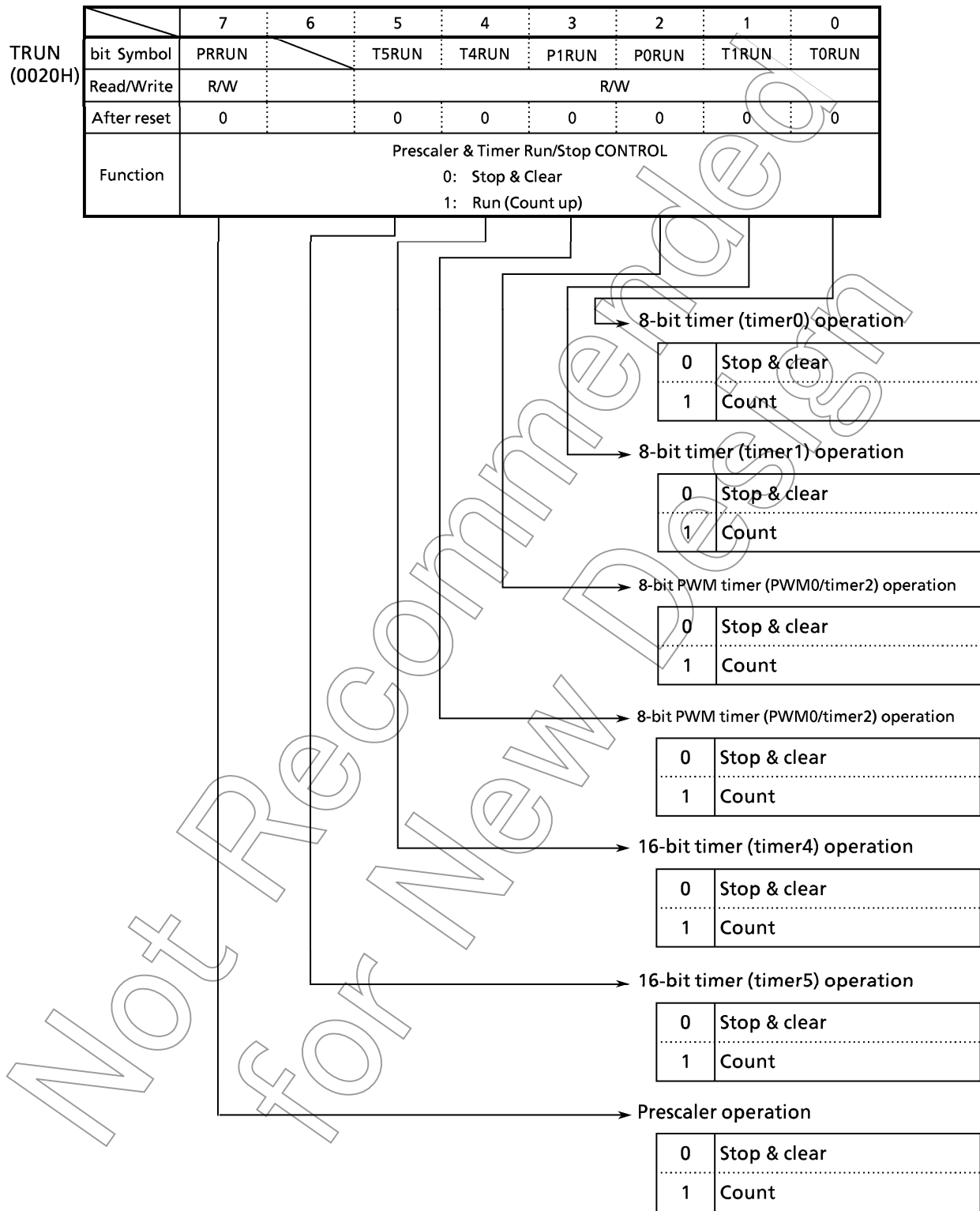

Figure 3.8 (7) Timer operation control register (TRUN)

The following explains PWM timer operations.

(1) PWM timer mode

Both PWM timers can output 8-bit resolution PWM independently. Since both timers operate in exactly the same way, PWM0 is used for the purposes of explanation.

PWM output changes under the following two conditions.

Condition 1:

- TFF2 is cleared to 0 when the value in the up-counter (UC2) and the value set in the TREG2 match.
- TFF2 is set to 1 when a  $2^n-1$  counter overflow ( $n = 6, 7, \text{ or } 8$ ) occurs.

Condition 2:

- TFF2 is set to 1 when the value in the up-counter (UC2) and the value set in TREG2 match.
- TFF2 is cleared to 0 when a  $2^n-1$  counter overflow ( $n = 6, 7, \text{ or } 8$ ) occurs.

The up-counter (UC2) is cleared by a  $2^n-1$  counter overflow.

The PWM timer can output 0%-100% duty pulses because a  $2^n-1$  counter overflow has a higher priority. That is, to obtain 0% output (always low), the mode used to set TFF2 to 0 due to overflow ( $\text{PFFCR} \langle \text{FF2TRG1,0} \rangle = 1,0$ ) must be set and  $2^n-1$  (Value for overflow) must be set in TREG2. To obtain 100% output (always high), the mode must be changed:  $\text{PFFCR} \langle \text{FF2TRG1,0} \rangle = 1,1$  then the same operation is required.

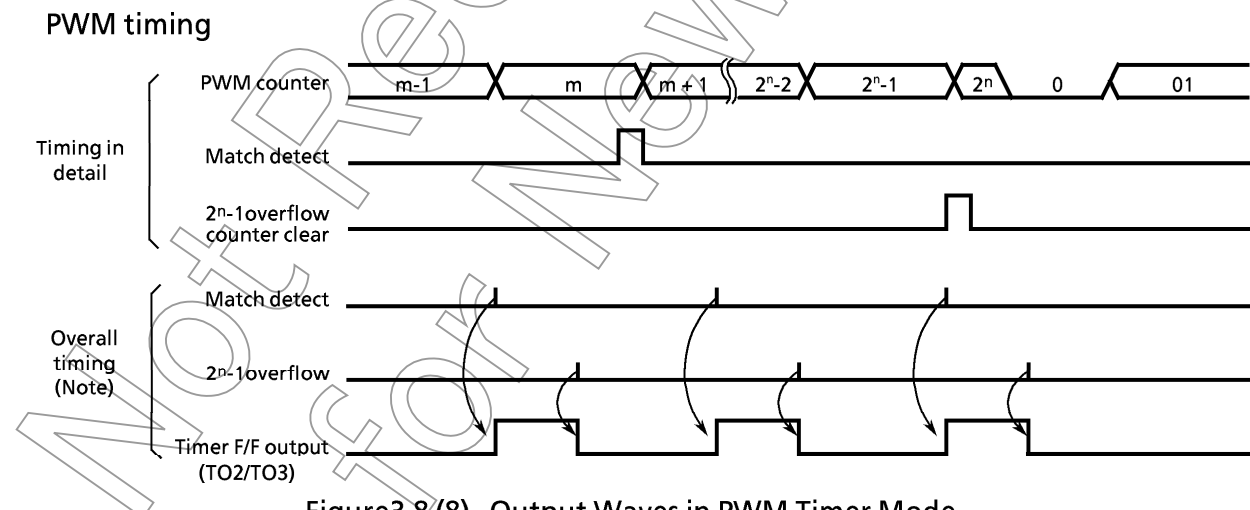
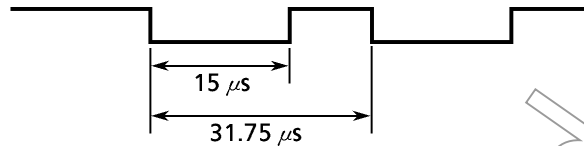

Figure3.8 (8) Output Waves in PWM Timer Mode

Note: The above waves are obtained in a mode where the F/F is set by a match with the timer register (TREG) and reset by an overflow.



Example: To output the following PWM waves to TO2 pin using PWM0 at  $f_c = 16 \text{ MHz}$



To implement  $31.75 \mu\text{s}$  PWM cycle by  $\phi P1 = 0.25 \mu\text{s}$  (@  $f_c = 16 \text{ MHz}$ )

$$31.75 \mu\text{s} \div 0.25 \mu\text{s} = 127 = 2^7 - 1.$$

Consequently, set n to 7.

Since the low level cycle =  $15 \mu\text{s}$ ; for  $\phi P1 = 0.25 \mu\text{s}$

$$15 \mu\text{s} \div 0.25 = 60 = 3\text{CH}$$

set the 3CH in TREG2.

7 6 5 4 3 2 1 0	
TRUN ← - X - - - 0 - -	Stops PWM0 and clears it to 0.
POMOD ← - 0 0 0 0 0 0 1	Sets PWM (27-1) mode, input clock $\phi P1$ , overflow interrupt, and disables double buffer.
TREG2 ← 0 0 1 1 1 1 0 0	Writes 3CH.
POMOD ← - 1 0 0 0 0 0 1	Enables double buffer.
PFFCR ← - - - - 0 1 1 1	Sets TFF2 and a mode where TFF2 is set by compare and match, and cleared by overflow.
P7CR ← X X X X - 1 - -	} Sets P72 as TO2 pin
P7FC ← X X X X - 1 - X	
TRUN ← 1 X - - - 1 - -	Starts PWM0 counting.

Note: X; Don't care -; No change

Table3.8 (1) PWM Cycle and  $2^n - 1$  Counter Setting

	Formula	16 MHz			20 MHz		
		$\phi P1$	$\phi P4$	$\phi P16$	$\phi P1$	$\phi P4$	$\phi P16$
26-1	$26-1 \times \phi Pn$	15.8 $\mu\text{s}$ (63 kHz)	63.0 $\mu\text{s}$ (16 kHz)	252 $\mu\text{s}$ (3.9 kHz)	12.6 $\mu\text{s}$ (79 kHz)	50.4 $\mu\text{s}$ (20 kHz)	201 $\mu\text{s}$ (4.9 kHz)
27-1	$27-1 \times \phi Pn$	31.8 $\mu\text{s}$ (31 kHz)	127.0 $\mu\text{s}$ (7.9 kHz)	508 $\mu\text{s}$ (1.9 kHz)	25.4 $\mu\text{s}$ (39 kHz)	101.6 $\mu\text{s}$ (9.8 kHz)	406 $\mu\text{s}$ (2.5 kHz)
28-1	$28-1 \times \phi Pn$	63.8 $\mu\text{s}$ (16 kHz)	255.0 $\mu\text{s}$ (3.9 kHz)	1020 $\mu\text{s}$ (0.98 kHz)	51.0 $\mu\text{s}$ (20 kHz)	204.0 $\mu\text{s}$ (4.9 kHz)	816 $\mu\text{s}$ (1.2 kHz)



## (2) 8-bit timer mode

Both PWM timers can be used independently as 8-bit interval timers. Since both timers operate in exactly the same way, PWM0 (timer 2) is used for the purposes of explanation.

## ① Generating interrupts at a fixed interval

To generate timer 2 interrupt (INTT2) at a fixed interval using PWM0 timer, first stop PWM0, then set the operating mode, input clock, and interval in the P0MOD and TREG2 registers. Next, enable INTT2 and start counting PWM0.

Example: To generate a timer 2 interrupt every 40  $\mu\text{s}$  at  $f_c = 16 \text{ MHz}$ , set registers as follows:

	7 6 5 4 3 2 1 0	
TRUN	← - X - - - 0 - -	Stops PWM0 and clears it to 0.
P0MOD	← X 0 1 1 0 0 X X	Sets 8-bit timer mode and selects $\phi\text{P1}$ (0.25 $\mu\text{s}$ ) and compare interrupt.
TREG2	← 1 0 1 0 0 0 0 0	Sets 40 $\mu\text{s}$ / 0.25 $\mu\text{s}$ = A0H in timer register.
INTEPW10	← - - - - 1 1 0 0	Enables INTT2 and sets interrupt level 4.
TRUN	← 1 X - - - 1 - -	Starts counting PWM0.

Note: X; Don't care -; No change

Select an input clock using the table below.

Table3.8 (2) Interrupt Cycle and Input Clock Selection using 8-bit timer mode

Input clock	Interrupt cycle (@ $f_c = 16 \text{ MHz}$ )	Resolution	Interrupt cycle (@ $f_c = 20 \text{ MHz}$ )	Resolution
$\phi\text{P1}$ (4/ $f_c$ )	0.25 $\mu\text{s}$ to 64 $\mu\text{s}$	0.25 $\mu\text{s}$	0.2 $\mu\text{s}$ to 51.2 $\mu\text{s}$	0.2 $\mu\text{s}$
$\phi\text{P4}$ (16/ $f_c$ )	1 $\mu\text{s}$ to 256 $\mu\text{s}$	1 $\mu\text{s}$	0.8 $\mu\text{s}$ to 204.8 $\mu\text{s}$	0.8 $\mu\text{s}$
$\phi\text{P16}$ (64/ $f_c$ )	4 $\mu\text{s}$ to 1024 $\mu\text{s}$	4 $\mu\text{s}$	3.2 $\mu\text{s}$ to 819.2 $\mu\text{s}$	3.2 $\mu\text{s}$

Note: To generate interrupts in 8-bit timer mode, bit 5 (interrupt control bit <PWM0INT> / <PWM1INT> of P0MOD/P1MOD) must be set to 1.

② Generating a 50 % square wave

To generate a 50 % square wave, invert the timer flip-flop at a fixed interval and output the timer flip-flop value to the timer output pin (TO2).

Example: To output a 3.0  $\mu\text{s}$  square wave at  $f_c = 16 \text{ MHz}$  from TO2 pin, set registers as follows.

	7 6 5 4 3 2 1 0	
TRUN	$\leftarrow$ - X - - - 0 - -	Stops PWM0 and clears it to 0.
POMOD	$\leftarrow$ X 0 1 1 0 0 X X	Sets 8-bit timer mode and selects $\phi\text{P1}$ ( $0.25 \mu\text{s}$ ) as the input clock.
TREG2	$\leftarrow$ 0 0 0 0 0 1 1 0	Sets $3.0 \mu\text{s} / 0.25 \mu\text{s} / 2 = 6$ in the timer register.
PFFCR	$\leftarrow$ - - - - 1 0 0 1	Clears TFF2 to 0 and inverts using comparator output.
P7CR	$\leftarrow$ X X X X - 1 - -	} Sets P72 as TO2 pin.
P7FC	$\leftarrow$ X X X X - 1 - X	
TRUN	$\leftarrow$ 1 X - - - 1 - -	Starts counting PWM0.

Note: X; Don't care -; No change

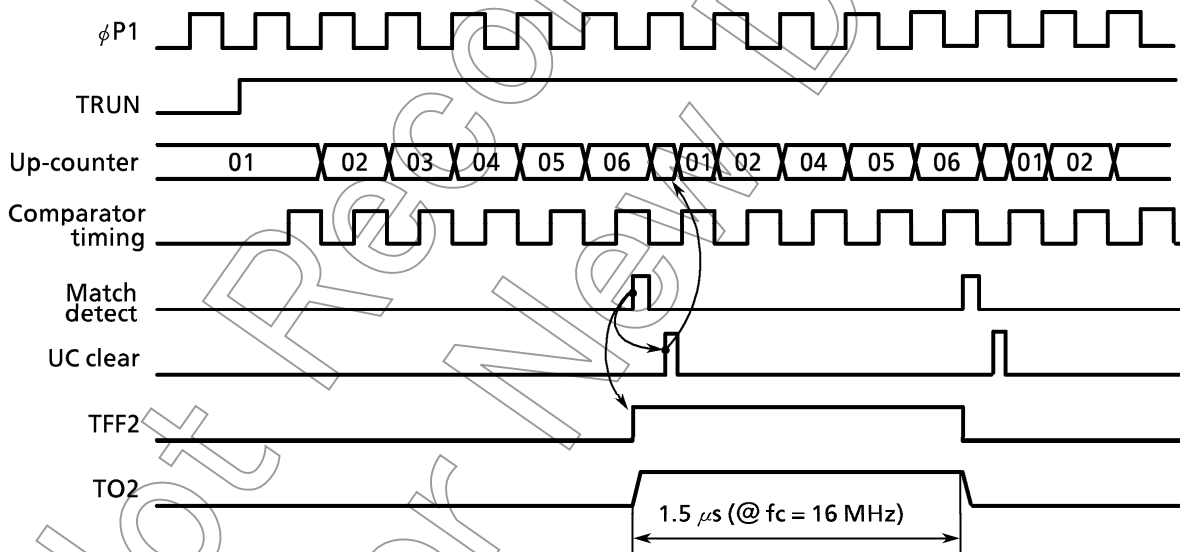

Figure3.8 (11) Square Wave (50 % Duty) Output Timing Chart

This mode is as shown in Figure 3.8 (12) below.

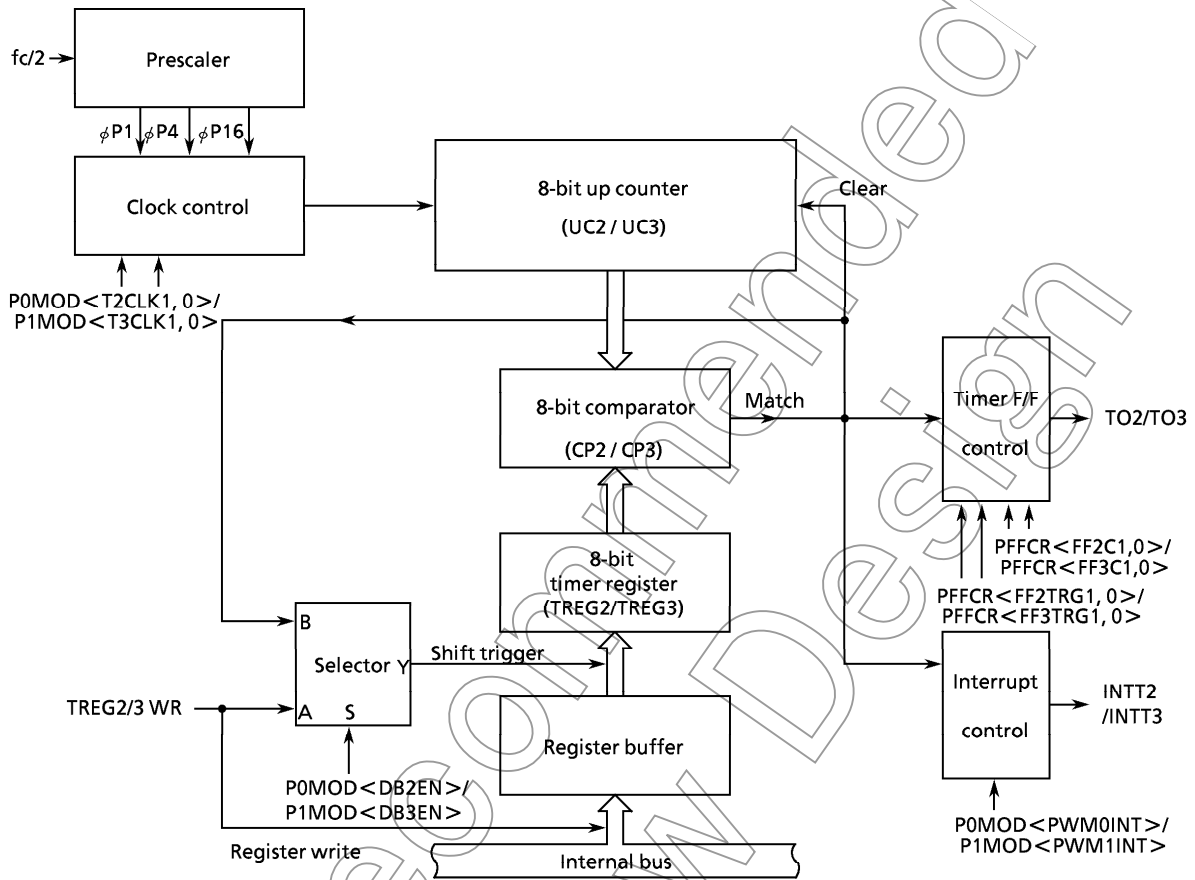

Figure3.8 (12) Block Diagram of 8-bit Timer Mode

### 3.9 16-bit Timer

TMP96C141B has two (timer 4 and timer 5) multifunctional 16-bit timer/event counter with the following operation modes.

- 16-bit interval timer mode
- 16-bit event counter mode
- 16-bit programmable pulse generation (PPG) mode
- Frequency measurement mode
- Pulse width measurement mode
- Time differential measurement mode

Timer/event counter consists of 16-bit up-counter, two 16-bit timer registers (One of them applies double-buffer), two 16-bit capture registers, two comparators, capture input controller, and timer flip-flop and the control circuit.

Timer/event counter is controlled by 4 control registers: T4MOD/T5MOD, T4FFCR / T5FFCR, TRUN and T45CR.

Figure 3.9 (1), (2) shows the block diagram of 16-bit timer/event counter (timer 4 and timer 5).

Not Recommended for New Design

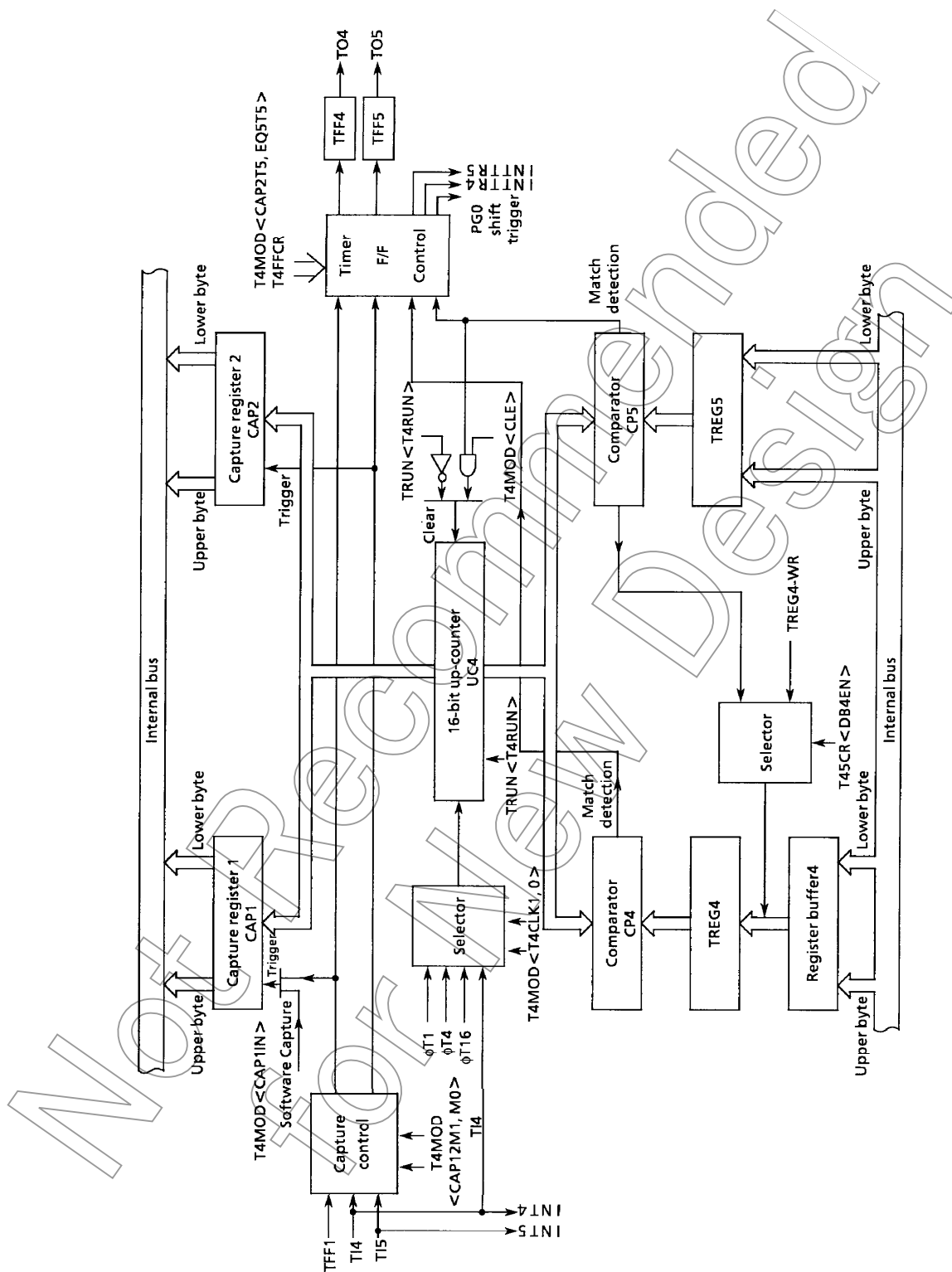

Figure 3.9 (1) Block Diagram of 16-Bit Timer (Timer 4)



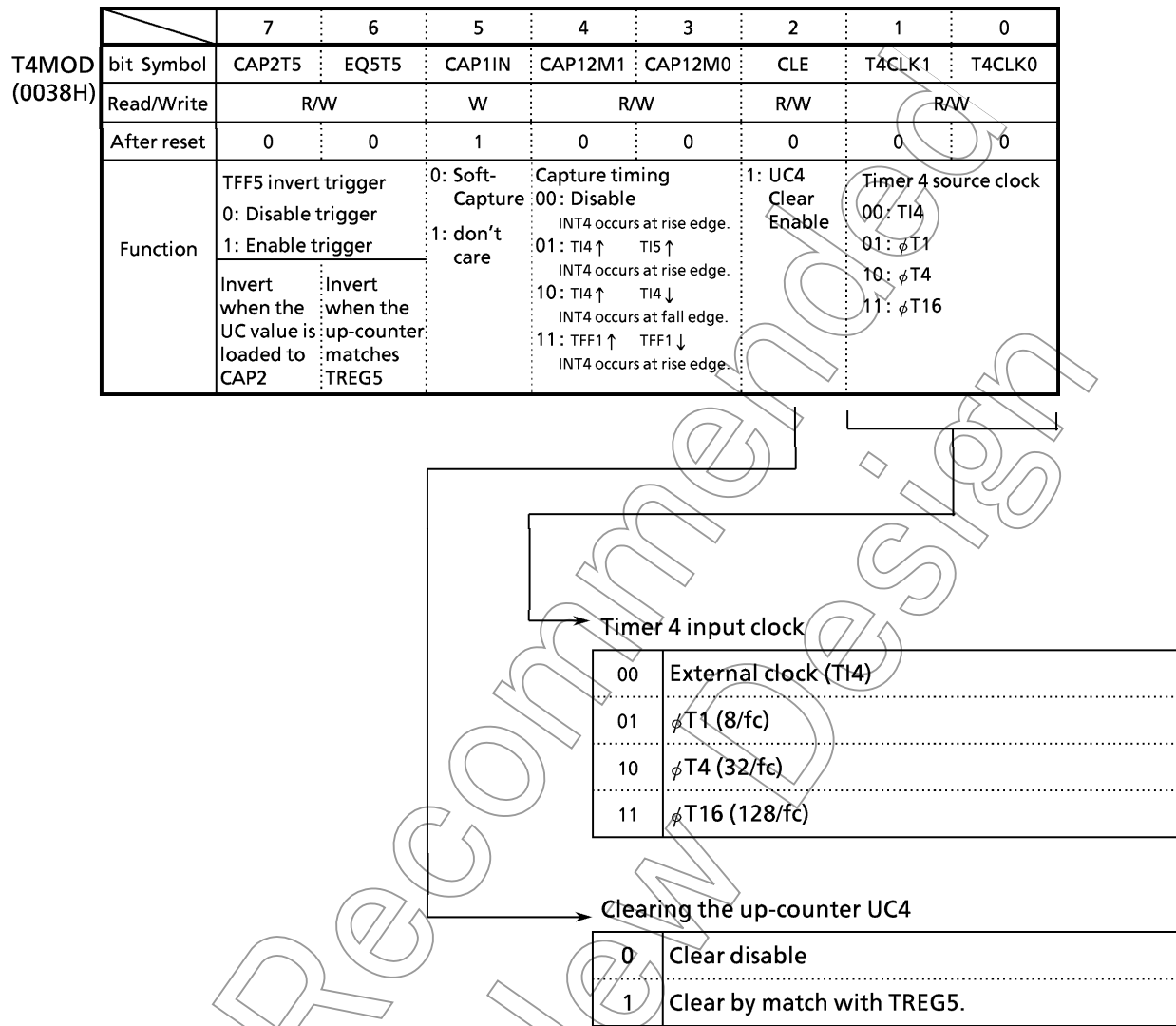
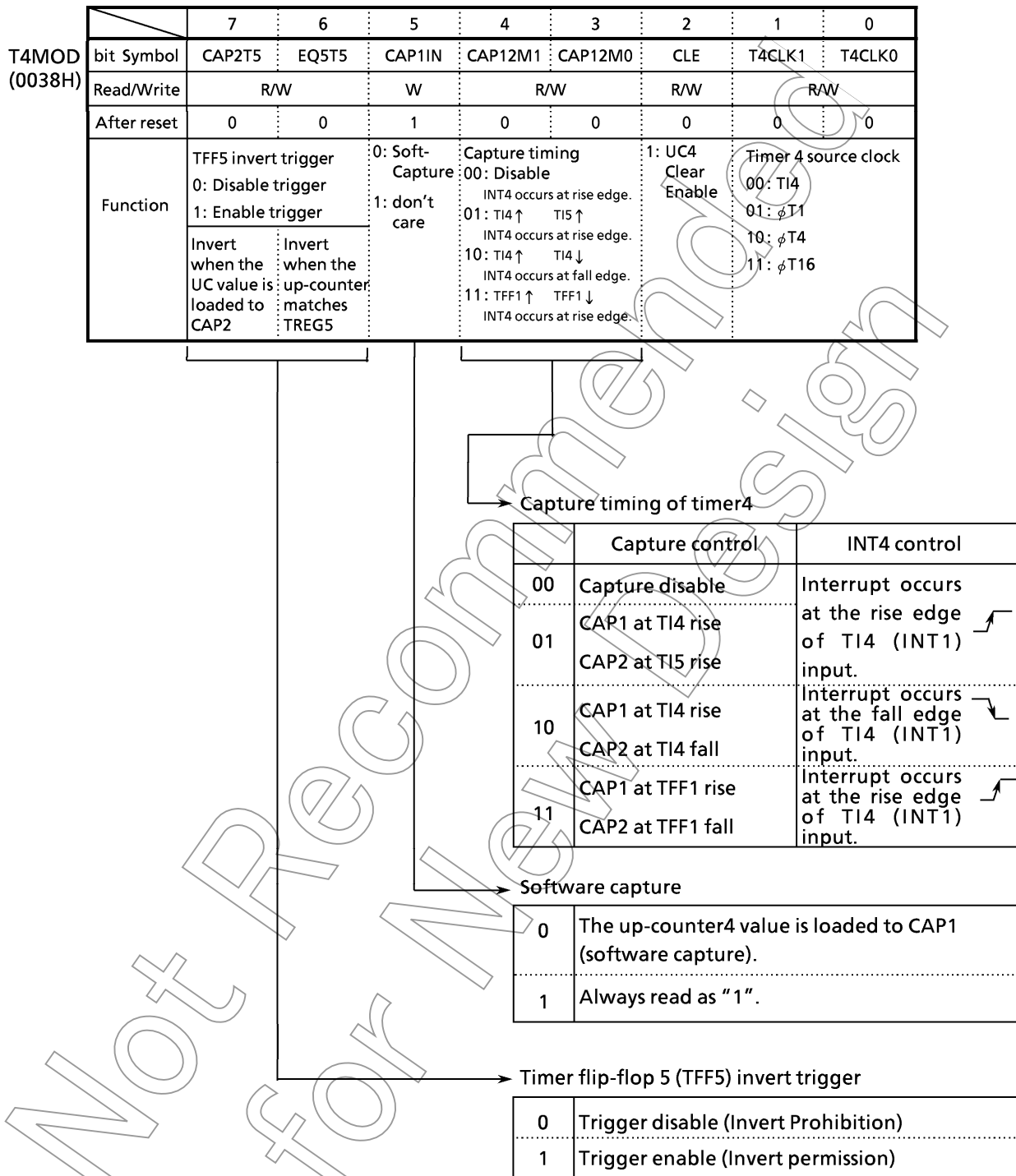

Figure 3.9 (3) 16-Bit Timer Mode Controller Register (T4MOD) (1/2)



CAP2T5 : Invert when the up-counter value is loaded to CAP2  
 EQ5T5 : Invert when the up-counter matches TREG5

Figure 3.9 (4) 16-Bit Timer Controller Register (T4MOD) (2/2)



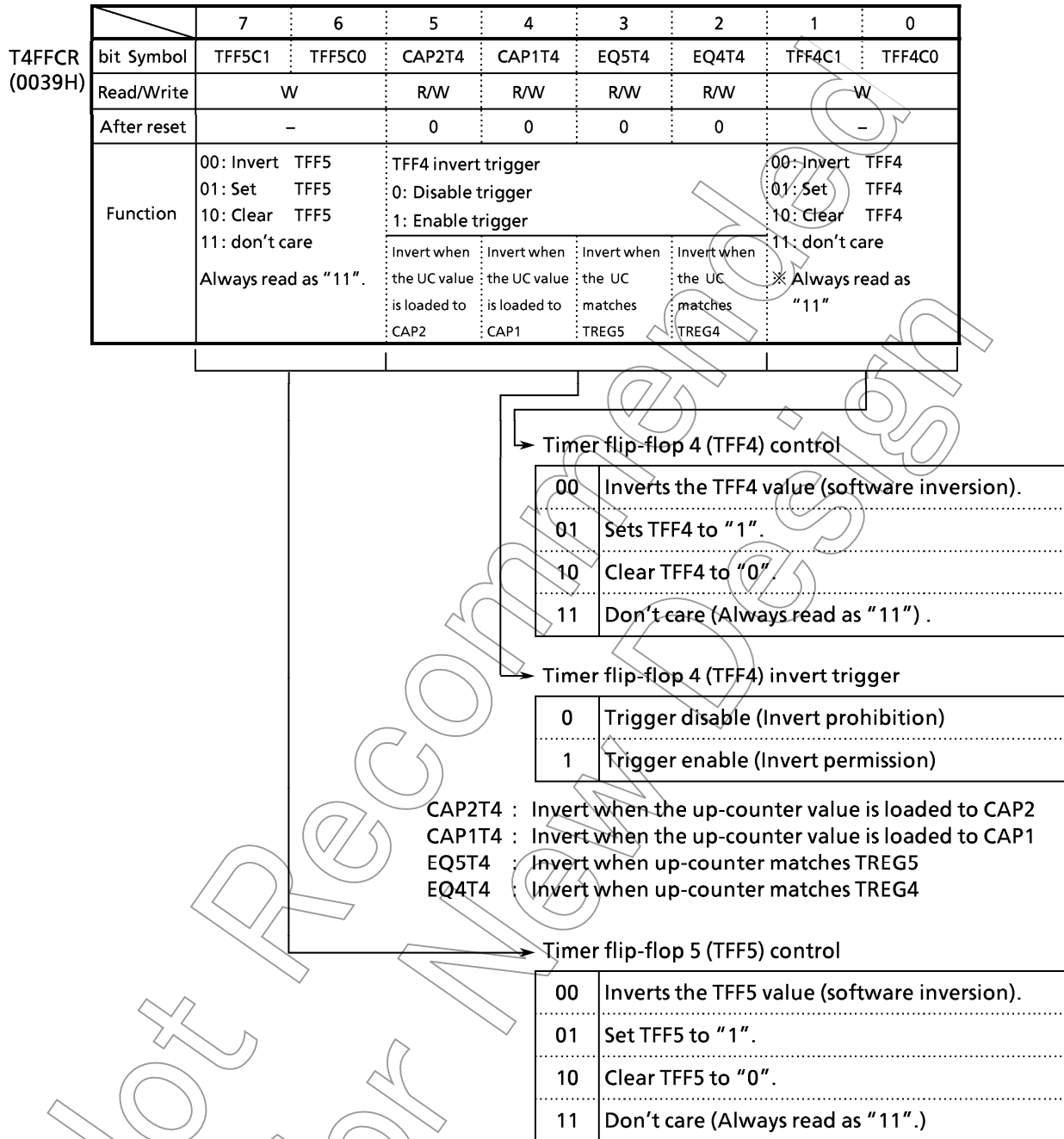

Figure 3.9 (5) 16-Bit Timer 4 F/F Control (T4FFCR)

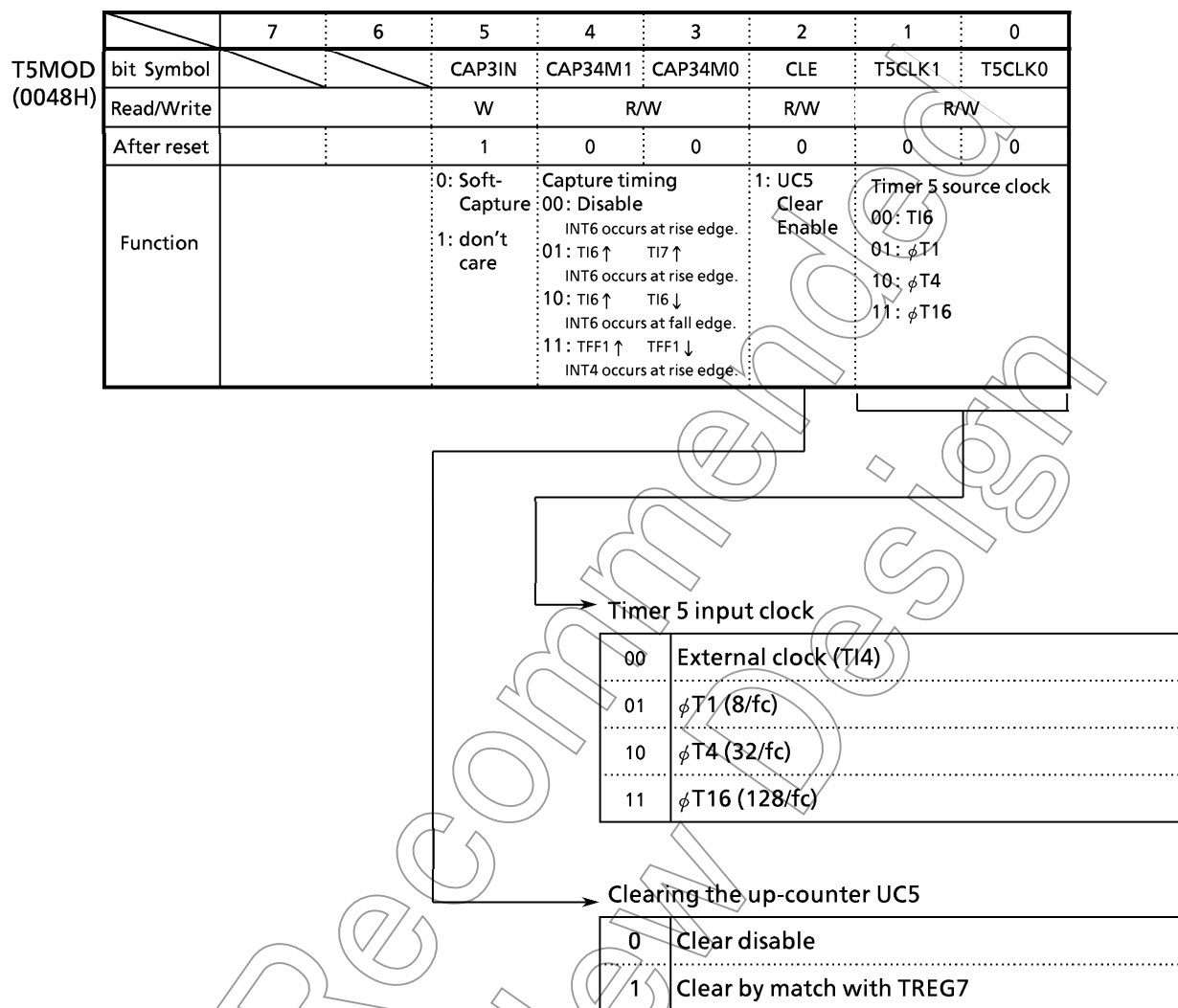

Figure 3.9 (6) 16-bit Timer Mode Control Register (T5MOD) (1/2)

Not Recommended for New Designs

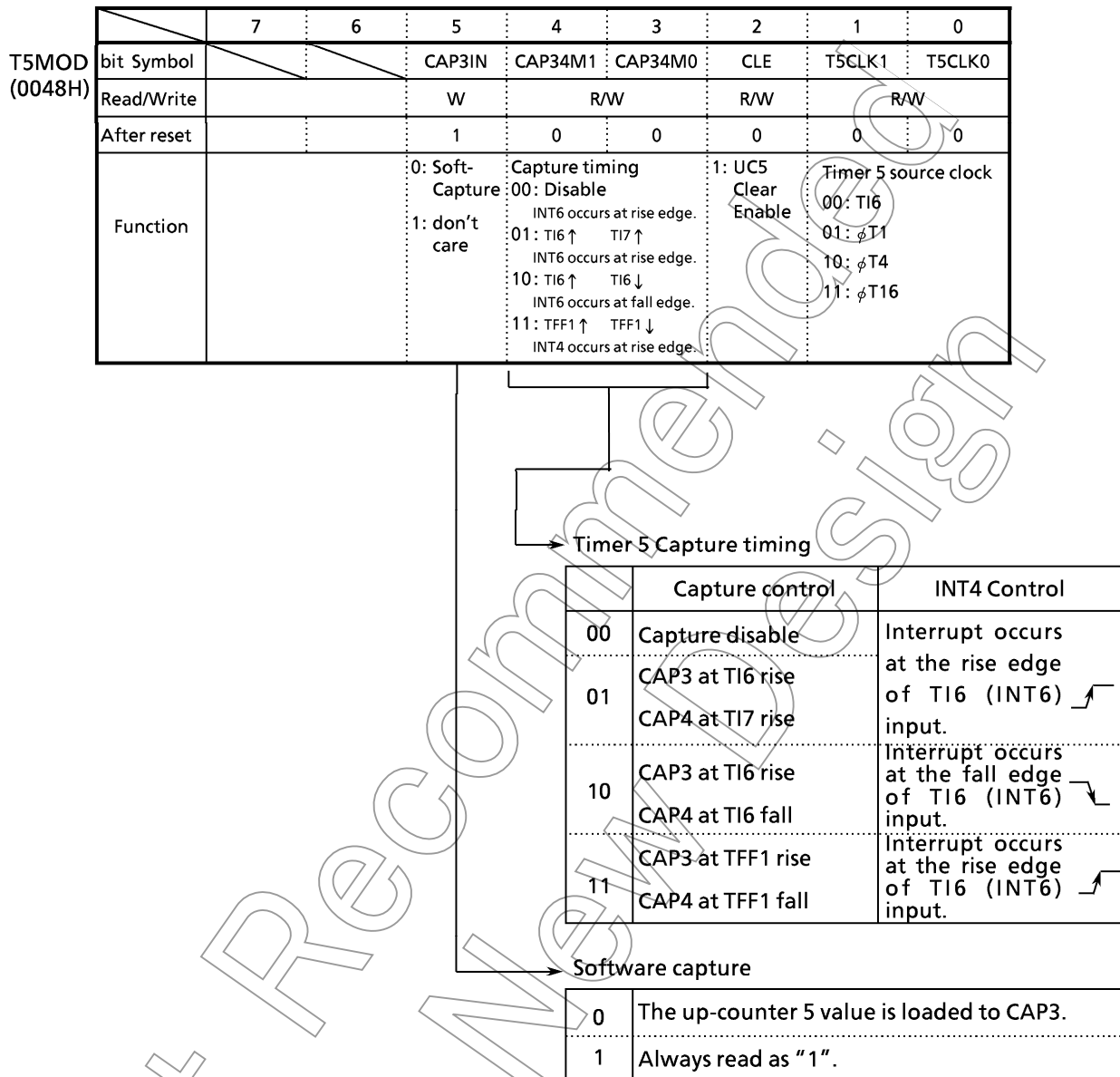

Figure 3.9 (7) 16-Bit Timer Control Register (T5MOD) (2/2)

	7	6	5	4	3	2	1	0
T5FFCR (0049H)			CAP4T6	CAP3T6	EQ7T6	EQ6T6	TFF6C1	TFF6C0
Read/Write			R/W	R/W	R/W	R/W	W	
After reset			0	0	0	0	—	
Function			TFF6 invert trigger 0: Disable trigger 1: Enable trigger  Invert when the UC value is loaded to CAP4 : Invert when the UC value is loaded to CAP3 : Invert when the UC matches TREG7 : Invert when the UC matches TREG6				00: Invert TFF6 01: Set TFF6 10: Clear TFF6 11: don't care ※ Always read as "11"	

→ Timer flip-flop 6 (TFF6) control

00	Inverts the TFF4 value (software inversion).
01	Sets TFF6 to "1".
10	Clear TFF6 to "0".
11	Don't care (Always read as "11").

→ Timer flip-flop 6 (TFF6) invert trigger

0	Trigger disable (Invert prohibition)
1	Trigger enable (Invert permission)

CAP4T6 : Invert when the up-counter value is loaded to CAP4  
 CAP3T6 : Invert when the up-counter value is loaded to CAP3  
 EQ7T6 : Invert when up-counter matches TREG7  
 EQ6T6 : Invert when up-counter matches TREG6

Figure 3.9 (8) 16-Bit Timer5 F/F Control (T5FFCR)

Not Recommended for New Design

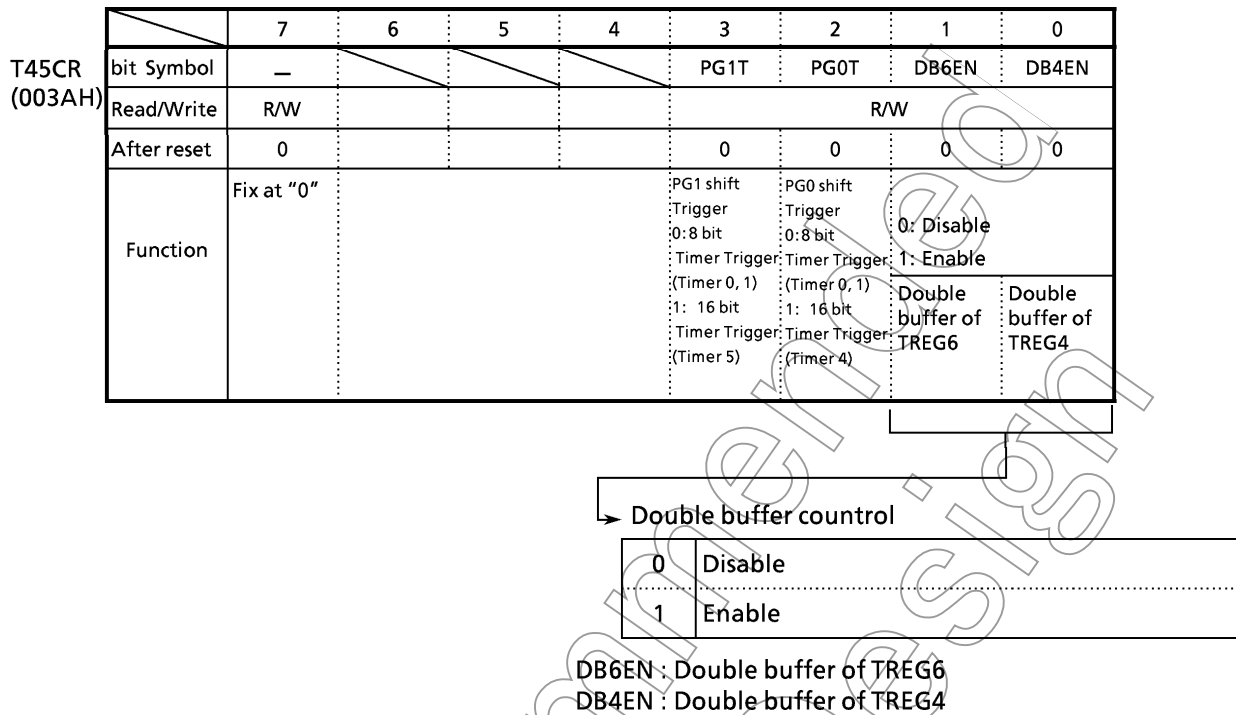

Figure 3.9 (9) 16-Bit Timer (Timer 4, 5) Control Register (T45CR)

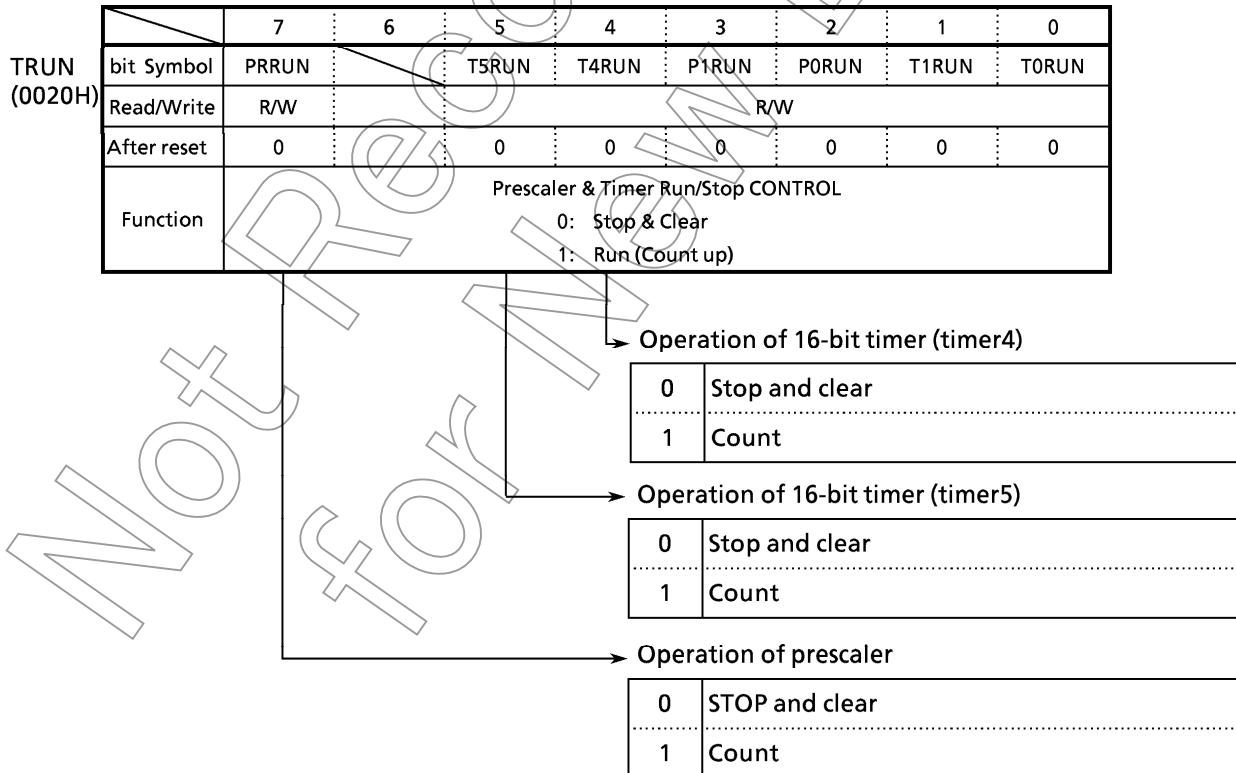

Figure 3.9 (10) Timer Operation Control Register (TRUN)

## ① Up-counter (UC4/UC5)

UC4/UC5 is a 16-bit binary counter which counts up according to the input clock specified by T4MOD<T4CLK1,0> or T5MOD<T5CLK1,0> register.

As the input clock, one of the internal clocks  $\phi$ T1 (8/fc),  $\phi$ T4 (32/fc), and  $\phi$ T16 (128/fc) from 9-bit prescaler (also used for 8-bit timer), and external clock from TI4 pin (also used as P80/INT4 pin) or TI6 (also used as P84/INT6 pin) can be selected. When reset, it will be initialized to <T4CLK1,0> / <T5CLK1,0> = 00 to select TI4/TI6 input mode. Counting or stop & clear of the counter is controlled by timer operation control register TRUN<T4RUN, T5RUN>.

When clearing is enabled, up-counter UC4/UC5 will be cleared to zero each time it coincides matches the timer register TREG5, TREG7. The “clear enable/disable” is set by T4MOD<CLE> and T5MOD<CLE>.

If clearing is disabled, the counter operates as a free-running counter.

## ② Timer Registers

These two 16-bit registers are used to set the interval time. When the value of up-counter UC4/UC5 matches the set value of this timer register, the comparator match detect signal will be active.

Setting data for timer register (TREG4, TREG5, TREG6 and TREG7) is executed using 2 byte data transfer instruction or using 1 byte data transfer instruction twice for lower 8 bits and upper 1 bits in order.

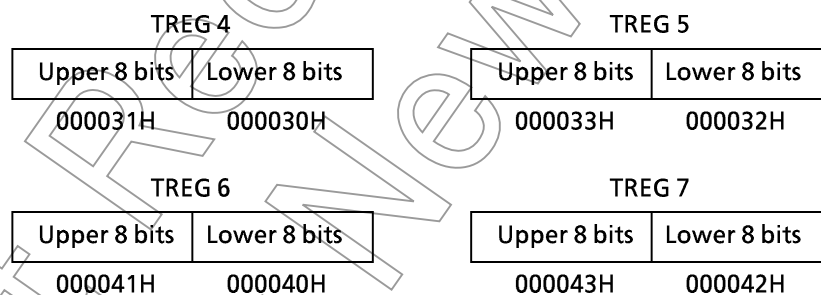

TREG4 and TREG6 timer register is of double buffer structure, which is paired with register buffer. The timer control register T45CR<DB4EN, DB6EN> controls whether the double buffer structure should be enabled or disabled. : disabled when <DB4EN, DB6EN> = 0, while enabled when <DB4EN, DB6EN> = 1.

When the double buffer is enabled, the timing to transfer data from the register buffer to the timer register is at the match between the up-counter (UC4/UC5) and timer register TREG5/TREG7.

When reset, it will be initialized to  $\langle \text{DB4EN}, \text{DB6EN} \rangle = 0$ , whereby the double buffer is disabled. To use the double buffer, write data in the timer register, set  $\langle \text{DB4EN}, \text{DB6EN} \rangle = 1$ , and then write the following data in the register buffer.

TREG4, TREG6 and register buffer are allocated to the same memory addresses 000030H/000031H/000040H/000041H. When  $\langle \text{DB4EN}, \text{DB6EN} \rangle = 0$ , same value will be written in both the timer register and register buffer. When  $\langle \text{DB4EN}, \text{DB6EN} \rangle = 1$ , the value is written into only the register buffer.

### ③ Capture Register

These 16-bit registers are used to hold the values of the up-counter.

Data in the capture registers should be read by a 2-byte data load instruction or two 1-byte data load instruction, from the lower 8 bits followed by the upper 8 bits.

CAP 1		CAP 2	
Upper 8 bits	Lower 8 bits	Upper 8 bits	Lower 8 bits
000035H	000034H	000037H	000036H

CAP 3		CAP 4	
Upper 8 bits	Lower 8 bits	Upper 8 bits	Lower 8 bits
000045H	000044H	000047H	000046H

### ④ Capture Input Control

This circuit controls the timing to latch the value of up-counter UC4/UC5 into (CAP1, CAP2) / (CAP3, CAP4). The latch timing of capture register is controlled by register T4MOD  $\langle \text{CAP12M1}, 0 \rangle$  / T5MOD  $\langle \text{CAP34M1}, 0 \rangle$ .

- When T4MOD  $\langle \text{CAP12M1}, 0 \rangle$  / T5MOD  $\langle \text{CAP34M1}, 0 \rangle = 00$

Capture function is disabled. Disable is the default on reset.

- When  $T4MOD \langle CAP12M1, 0 \rangle / T5MOD \langle CAP34M1, 0 \rangle = 01$

Data is loaded to CAP1, CAP3 at the rise edge of TI4 pin (also used as P80/INT4) and TI6 pin (also used as P84/INT6) input, while data is loaded to CAP2, CAP4 at the rise edge of TI5 pin (also used as P81/INT5) and TI7 pin (also used as P85/INT7) input. (Time difference measurement)

- When  $T4MOD \langle CAP12M1, 0 \rangle / T5MOD \langle CAP34M1, 0 \rangle = 10$

Data is loaded to CAP1 at the rise edge of TI4 pin input and to CAP3 at the rise edge of TI6, while to CAP2, CAP4 at the fall edge. Only in this setting, interrupt INT4/INT6 occurs at fall edge. (Pulse width measurement)

- When  $T4MOD \langle CAP12M1, 0 \rangle / T5MOD \langle CAP34M1, 0 \rangle = 11$

Data is loaded to CAP1, CAP3 at the rise edge of timer flip-flop TFF1, while to CAP2, CAP4 at the fall edge.

Besides, the value of up-counter can be loaded to capture registers by software. Whenever "0" is written in  $T4MOD \langle CAPIN \rangle$ ,  $T5MOD \langle CAP31N \rangle$  the current value of up-counter will be loaded to capture register CAP1/CAP3. It is necessary to keep the prescaler in RUN mode ( $TRUN \langle PRRUN \rangle$  to be "1").

#### ⑤ Comparator

These are 16-bit comparators which compare the up-counter UC4/UC5 value with the set value of (TREG4, TREG5) / (TREG6, TREG7) to detect the match. When a match is detected, the comparators generate an interrupt (INTT4, INTT5) / (INTT6, INTT7) respectively. The up-counter UC4/UC5 is cleared only when UC4/UC5 matches TREG5/TREG7. (The clearing of up-counter UC4/UC5 can be disabled by setting  $T4MOD \langle CLE \rangle / T5MOD \langle CLE \rangle = 0$ .)

#### ⑥ Timer Flip-flop (TFF4/TFF6)

This flip-flop is inverted by the match detect signal from the comparators and the latch signals to the capture registers. Disable/enable of inversion can be set for each element by  $T4FFCR \langle CAP2T4, CAP1T4, EQ5T4, EQ4T4 \rangle / T6FFCR \langle CAP4T6, CAP3T6, EQ7T6, EQ6T6 \rangle$ . TFF4/TFF6 will be inverted when "00" is written in  $T4FFCR \langle TFF4C1, 0 \rangle / T6FFCR \langle TFF6C1, 0 \rangle$ . Also it is set to "1" when "10" is written, and cleared to "0" when "10" is written. The value of TFF4/TFF6 can be output to the timer output pin TO4 (also used as P82) and TO6 (also used as P86).



### ⑦ Timer Flip-flop (TFF5)

This flip-flop is inverted by the match detect signal from the comparator and the latch signal to the capture register CAP2. TFF5 will be inverted when “00” is written in T4FFCR<TFF5C1,0>/T6FFCR<TFF6C1, 0>. Also it is set to “1” when “10” is written, and cleared to “0” when “10” is written. The value of TFF5 can be output to the timer output pin TO5 (also used as P82).

Note : This flip-flop (TFF5) is contained only in the 16-bit timer 4

### (1) 16-bit Timer Mode

Timers 4 and 5 operate independently.

Since both timers operate in exactly the same way, timer 4 is used for the purposes of explanation.

Generating interrupts at fixed intervals

In this example, the interval time is set in the timer register TREG5 to generate the interrupt INTTR5.

	7 6 5 4 3 2 1 0	
TRUN	← - X - 0 - - -	Stop timer 4.
INTET54	← 1 1 0 0 1 0 0 0	Enable INTTR5 and sets interrupt level 4. Disable INTTR4.
T4FFCR	← 1 1 0 0 0 0 1 1	Disable trigger.
T4MOD	← 0 0 1 0 0 1 * *	Select internal clock for input and disable the capture function.
	(** = 01, 10, 11)	
TREG5	← * * * * * * * *	Set the interval time (16 bits).
	* * * * * * * *	
TRUN	← 1 X - 1 - - -	Start timer 4.
Note :	X ; Don't care    - ; No change	

### (2) 16-bit Event Counter Mode

In 16-bit timer mode as described in above, the timer can be used as an event counter by selecting the external clock (TI4/TI6 pin input) as the input clock. To read the value of the counter, first perform “software capture” once and read the captured value.

The counter counts at the rise edge of TI4/TI6 pin input.

TI4/TI6 pin can also be used as P80/INT4 and P84/INT6.

Since both timers operate in exactly the same way, timer 4 is used for the purposes of explanation.

	7 6 5 4 3 2 1 0	
TRUN	← - X - 0 - - - -	Stop timer 4.
P8CR	← - - - - - - - 0	Set P80 to input mode
INTET54	← 1 1 0 0 1 0 0 0	Enable INTTR5 and sets interrupt level 4, while disables INTTR4.
T4FFCR	← 1 1 0 0 0 0 1 1	Disable trigger.
T4MOD	← 0 0 1 0 0 1 0 0	Select T14 as the input clock.
TREG5	← * * * * * * * *	Set the number of counts (16 bits).
TRUN	← 1 X - 1 - - - -	Start timer 4.

Note : When used as an event counter, set the prescaler in RUN mode.

(3) 16-bit Programmable Pulse Generation (PPG) Output Mode

Since both timers operate in exactly the same way, timer 4 is used for the purposes of explanation.

The PPG mode is obtained by inversion of the timer flip-flop TFF4 that is to be enabled by the match of the up-counter UC4 with the timer register TREG4 or 5 and to be output to TO4 (also used as P82). In this mode, the following conditions must be satisfied.

$$(\text{Set value of TREG4}) < (\text{Set value of TREG5})$$

	7 6 5 4 3 2 1 0	
TRUN	← - X - 0 - - - -	Stop timer 4.
TREG4	← * * * * * * * *	Set the duty. (16-Bit)
TREG5	← * * * * * * * *	Set the cycle. (16-Bit)
T45CR	← 0 X X X - - - 1	Double Buffer of TREG4 enable (Change the duty and cycle at the interrupt INTTR5)
T4FFCR	← 1 1 0 0 1 1 0 0	Set the mode to invert TFF4 at the match with TREG4/TREG5, and also set the TFF4 to "0".
T4MOD	← 0 0 1 0 0 1 * *	Select the internal clock for the input, and disable the capture function.
	(** = 01, 10, 11)	
P8CR	← - - - - - 1 - -	} Assign P82 as TO4.
P8FC	← X - X X - 1 X X	
TRUN	← 1 X - 1 - - - -	Start timer 4.

Note : X ; Don't care - ; No change

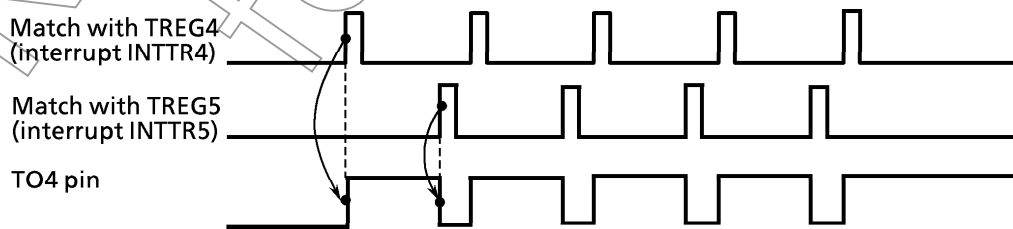

Figure 3.9 (11) Programmable Pulse Generation (PPG) Output Waveforms

When the double buffer of TREG4 is enabled in this mode, the value of register buffer 4 will be shifted in TREG4 at match with TREG5. This feature makes easy the handling of low duty waves.

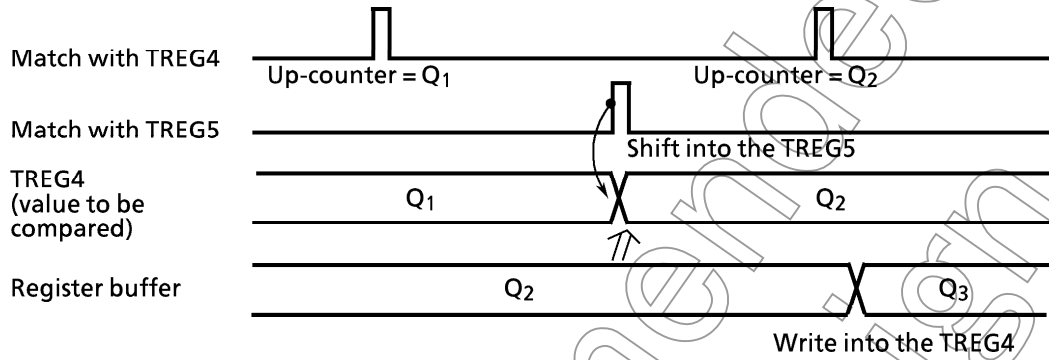

Figure 3.9 (12) Operation of Register Buffer

Shows the block diagram of this mode.

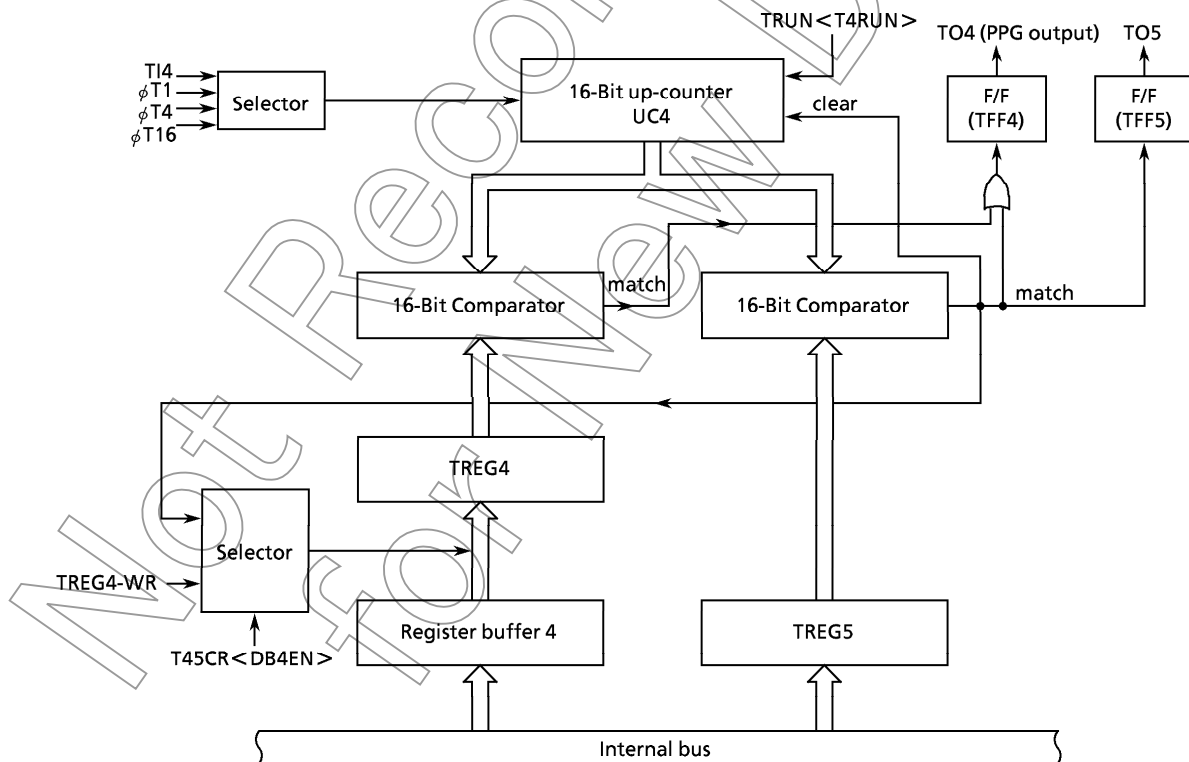

Figure 3.9 (13) Block Diagram of 16-Bit PPG Mode

## (4) Application Examples of Capture Function

The loading of up-counter (UC4) values into the capture registers CAP1 and CAP2, the timer flip-flop TFF4 inversion due to the match detection by comparators CP4 and CP5, and the output of the TFF4 status to TO4 pin can be enabled or disabled. Combined with interrupt function, they can be applied in many ways, for example:

- ① One-shot pulse output from external trigger pulse
- ② Frequency measurement
- ③ Pulse width measurement
- ④ Time difference measurement

## ① One-shot Pulse Output from External Trigger Pulse

Set the up-counter UC4 in free-running mode with the internal input clock, input the external trigger pulse from TI4 pin, and load the value of up-counter into capture register CAP1 at the rise edge of the TI4 pin. Then set to  $T4MOD < CAP12M1, 0 > = 01$ .

When the interrupt INT4 is generated at the rise edge of TI4 input, set the CAP1 value (c) plus a delay time (d) to TREG4 ( $= c + d$ ), and set the above set value ( $c + d$ ) plus a one-shot pulse width (p) to TREG5 ( $= c + d + p$ ). When the interrupt INT4 occurs the  $T4FFCR < EQ5T4, EQ4T4 >$  register should be set that the TFF4 inversion is enabled only when the up-counter value matches TREG4 or TREG5. When interrupt INTTR5 occurs, this inversion will be disabled.

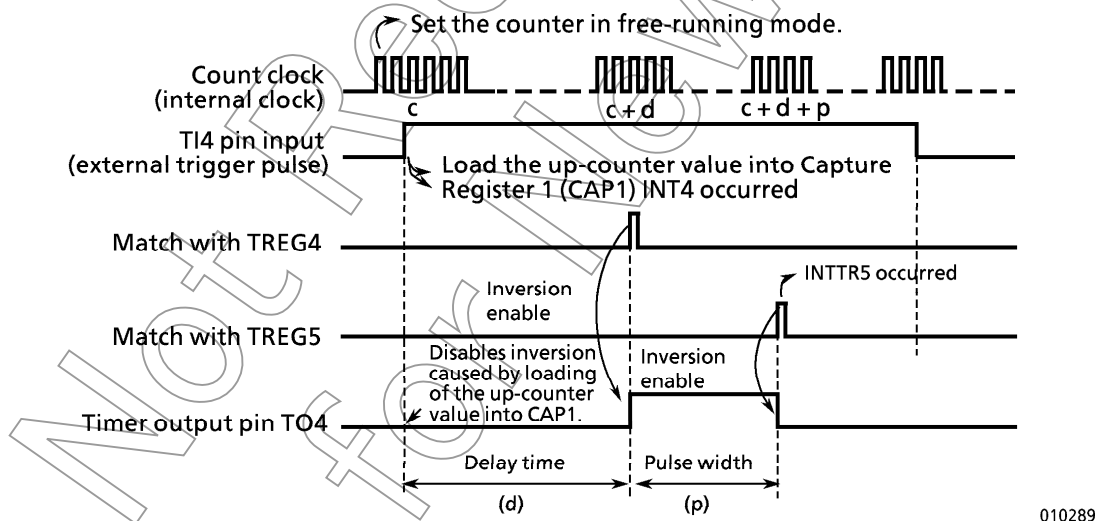

010289

Figure 3.9 (14) One-Shot Pulse Output (with Delay)

Setting example : To output 2ms one-shot pulse with 3ms delay to the external trigger pulse to TI4 pin

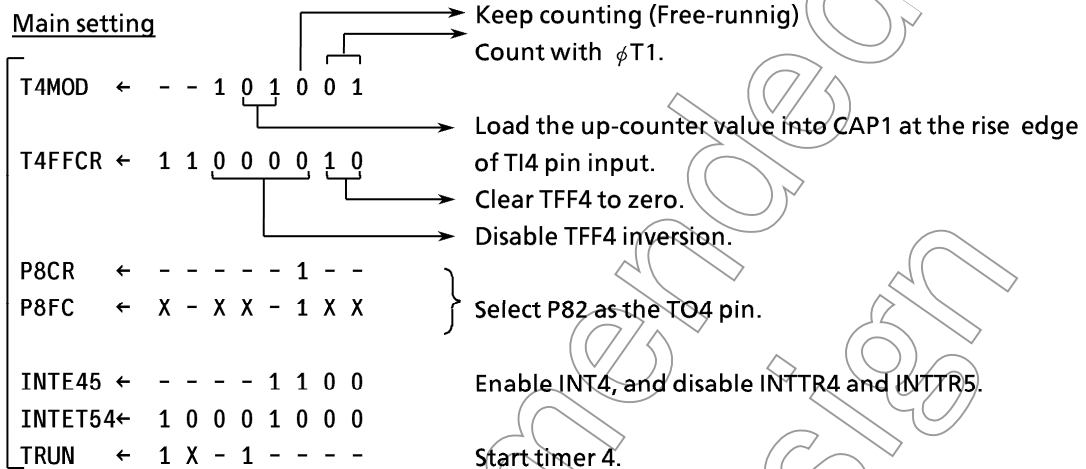

**Setting of INT4**

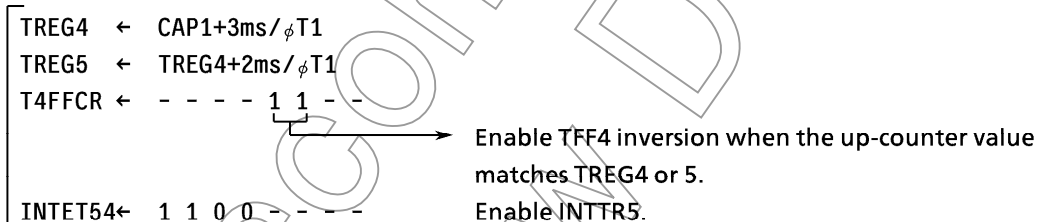

**Setting of INTTR5**

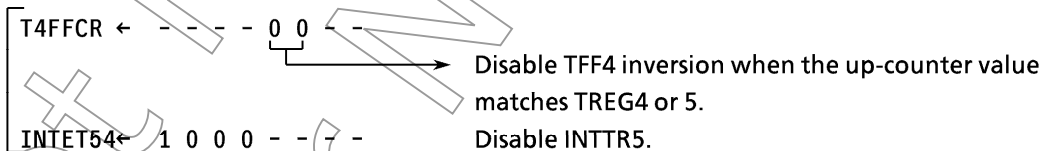

Note: X ; Don't care    - ; No change

When delay time is unnecessary, invert timer flip-flop TFF4 when the up-counter value is loaded into capture register 1 (CAP1), and set the CAP1 value (c) plus the one-shot pulse width (p) to TREG5 when the interrupt INT4 occurs. The TFF4 inversion should be enabled when the up-counter (UC4) value matches TREG5, and disabled when generating the interrupt INTTR5.

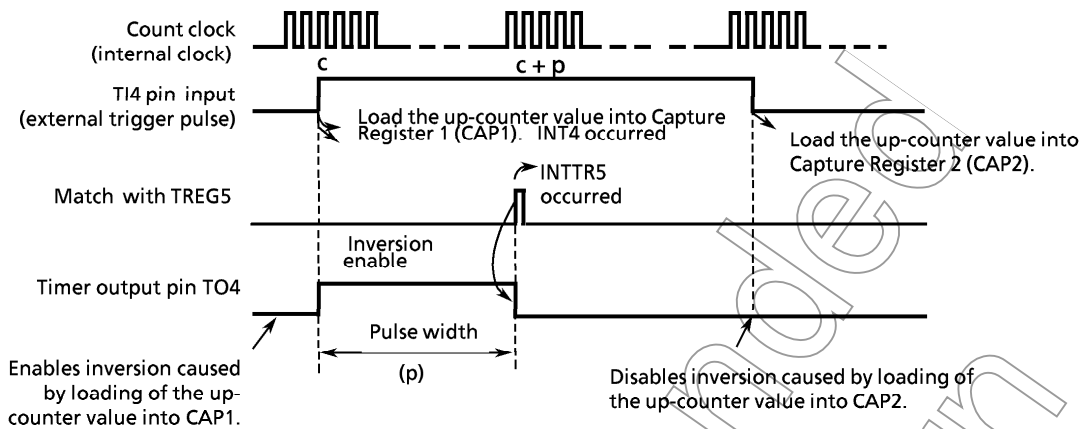

010289

Figure 3.9 (15) One-Shot Pulse Output (without Delay)

② Frequency Measurement

The frequency of the external clock can be measured in this mode. The clock is input through the TI4 pin, and its frequency is measured by the 8-bit timers (Timer 0 and Timer 1) and the 16-bit timer/event counter (Timer 4).

The TI4 pin input should be selected for the input clock of Timer 4. The value of the up-counter is loaded into the capture register CAP1 at the rise edge of the timer flip-flop TFF1 of 8-bit timers (Timer 0 and Timer 1), and into CAP2 at its fall edge.

The frequency is calculated by the difference between the loaded values in CAP1 and CAP2 when the interrupt (INTT0 or INTT1) is generated by either 8-bit timer.

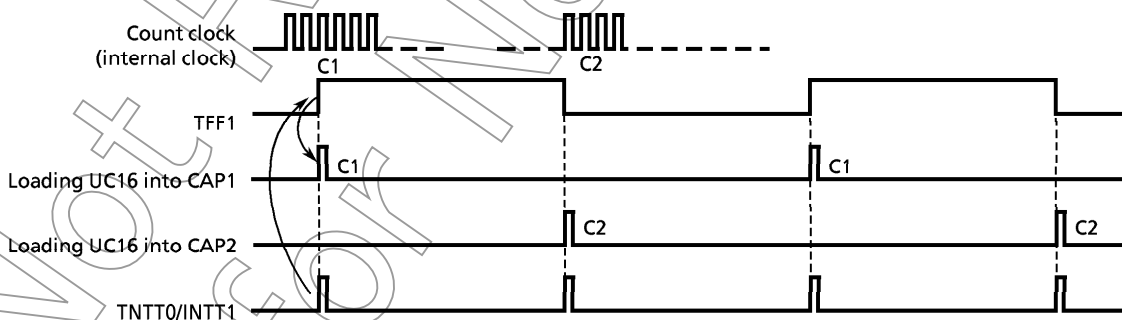

010289

Figure 3.9 (16) Frequency Measurement

For example, if the value for the level "1" width of TFF1 of the 8-bit timer is set to 0.5 s. and the difference between CAP1 and CAP2 is 100, the frequency will be  $100/0.5 [s] = 200[Hz]$ .

### ③ Pulse Width Measurement

This mode allows to measure the “H” level width of an external pulse. While keeping the 16-bit timer/event counter counting (free-running) with the internal clock input, the external pulse is input through the TI4 pin. Then the capture function is used to load the UC4 values into CAP1 and CAP2 at the rising edge and falling edge of the external trigger pulse respectively. The interrupt INT4 occurs at the falling edge of TI4.

The pulse width is obtained from the difference between the values of CAP1 and CAP2 and the internal clock cycle.

For example, if the internal clock is 0.8 microseconds and the difference between CAP1 and CAP2 is 100, the pulse width will be  $100 \times 0.8 = 80$  microseconds.

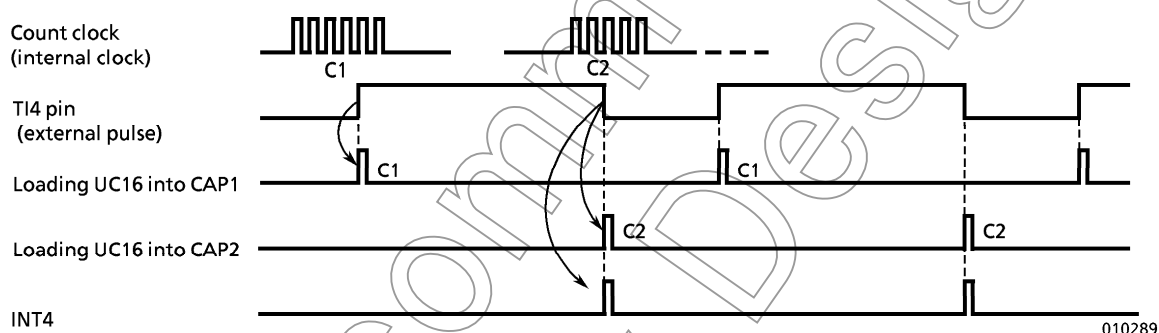

Figure 3.9 (17) Pulse Width Measurement

Note: Only in this pulse width measuring mode ( $T4MOD < CAP12M1, 0 > = 10$ ), external interrupt INT4 occurs at the falling edge of TI4 pin input. In other modes, it occurs at the rising edge.

The width of “L” level can be measured from the difference between the first C2 and the second C1 at the second INT4 interrupt.

### ④ Time Difference Measurement

This mode is used to measure the difference in time between the rising edges of external pulses input through TI4 and TI5.

Keep the 16-bit timer/event counter (Timer 4) counting (free-running) with the internal clock, and load the UC4 value into CAP1 at the rising edge of the input pulse to TI4. Then the interrupt INT4 is generated.

Similarly, the UC4 value is loaded into CAP2 at the rising edge of the input pulse to TI5, generating the interrupt INT5.

The time difference between these pulses can be obtained from the difference between the time counts at which loading the up-counter value into CAP1 and CAP2 has been done.

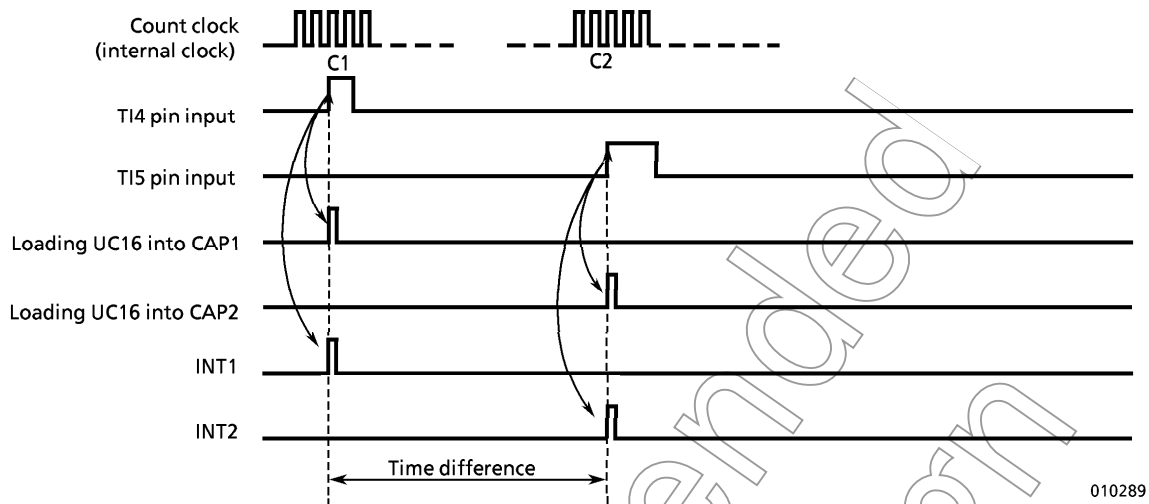

Figure 3.9 (18) Time Difference Measurement

(5) Different Phased Pulses Output Mode

In this mode, signals with any different phase can be outputted by free-running up-counter UC4.

When the value in up-counter UC4 and the value in TREG4 (TREG5) match, the value in TFF4 (TFF5) is inverted and output to TO4 (TO5).

This mode can only be used by 16-bit timer 4.

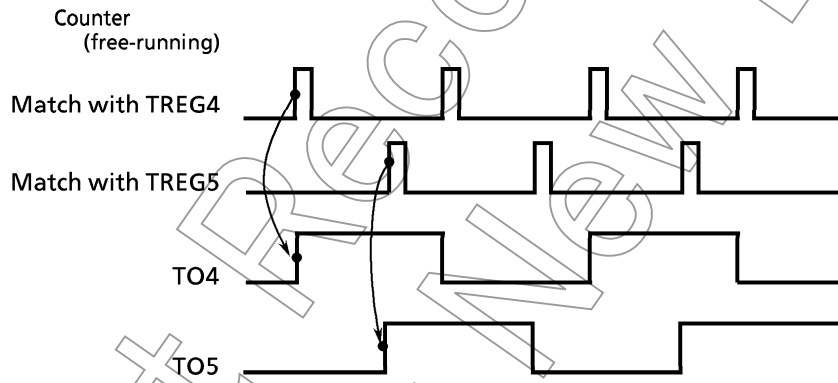

Figure 3.9 (19) Phase Output

Cycles (counter overflow time) of the above output waves are listed below.

	16 MHz	20 MHz
$\phi$ T1	32.768 ms	26.214 ms
$\phi$ T4	131.072 ms	104.856 ms
$\phi$ T16	524.288 ms	419.424 ms



3.10 Stepping Motor Control/Pattern Generation Port

TMP96C141B has 2 channels (PG0 and PG1) of 4-bit hardware stepping motor control/pattern generation (herein after called PG) which actuate in synchronization with the (8-bit/16-bit) timers. The PG (PG0 and PG1) are shared in 8-bit I/O ports P6.

Channel 0 (PG0) is synchronous with 8-bit timer 0 or timer 1, 16-bit timer 5, to update the output.

The PG ports are controlled by control registers (PG01CR) and can select either stepping motor control mode or pattern generation mode. Each bit of the P6 can be used as the PG port.

PG0 and PG1 can be used independently.

All PG operate in the same manner except the following points, and thus only the operation of PG0 will be explained below.

Different Points between PG0 and PG1

	PG0	PG1
Tigger Signal	from Timmer 4	from Timmer 5

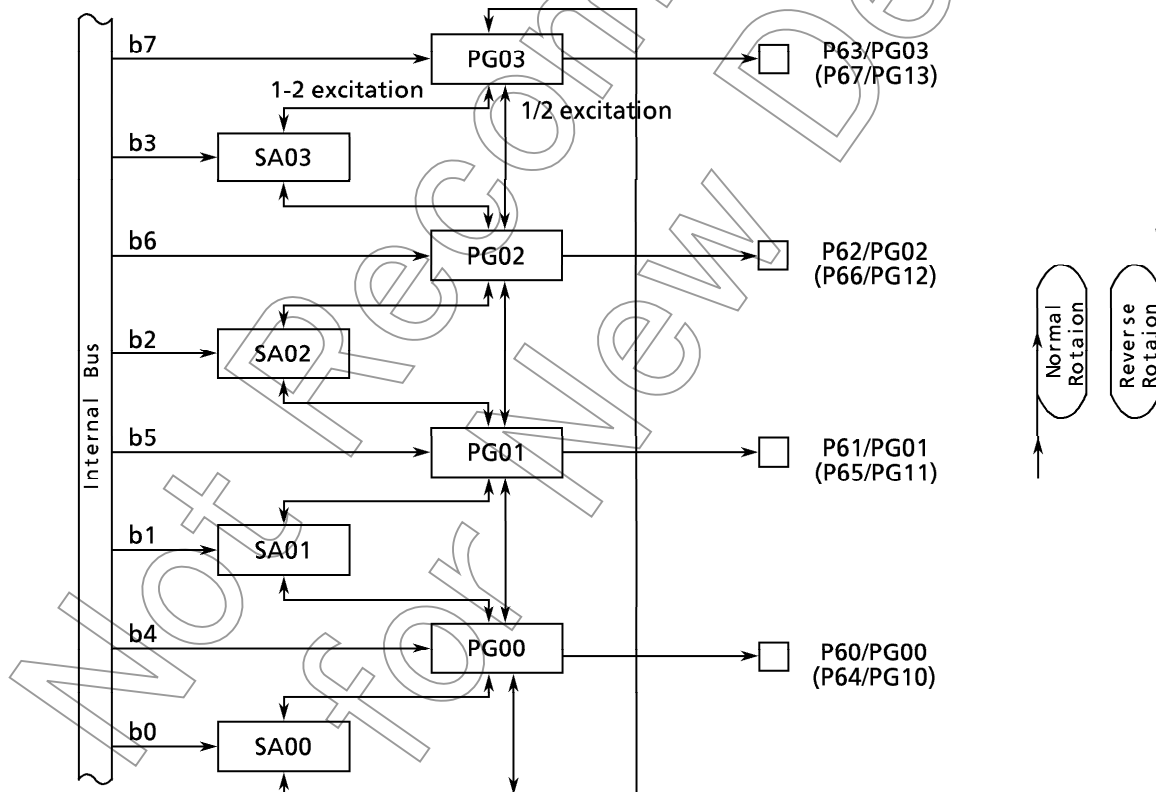

Figure 3.10 (1) PG Block Diagram

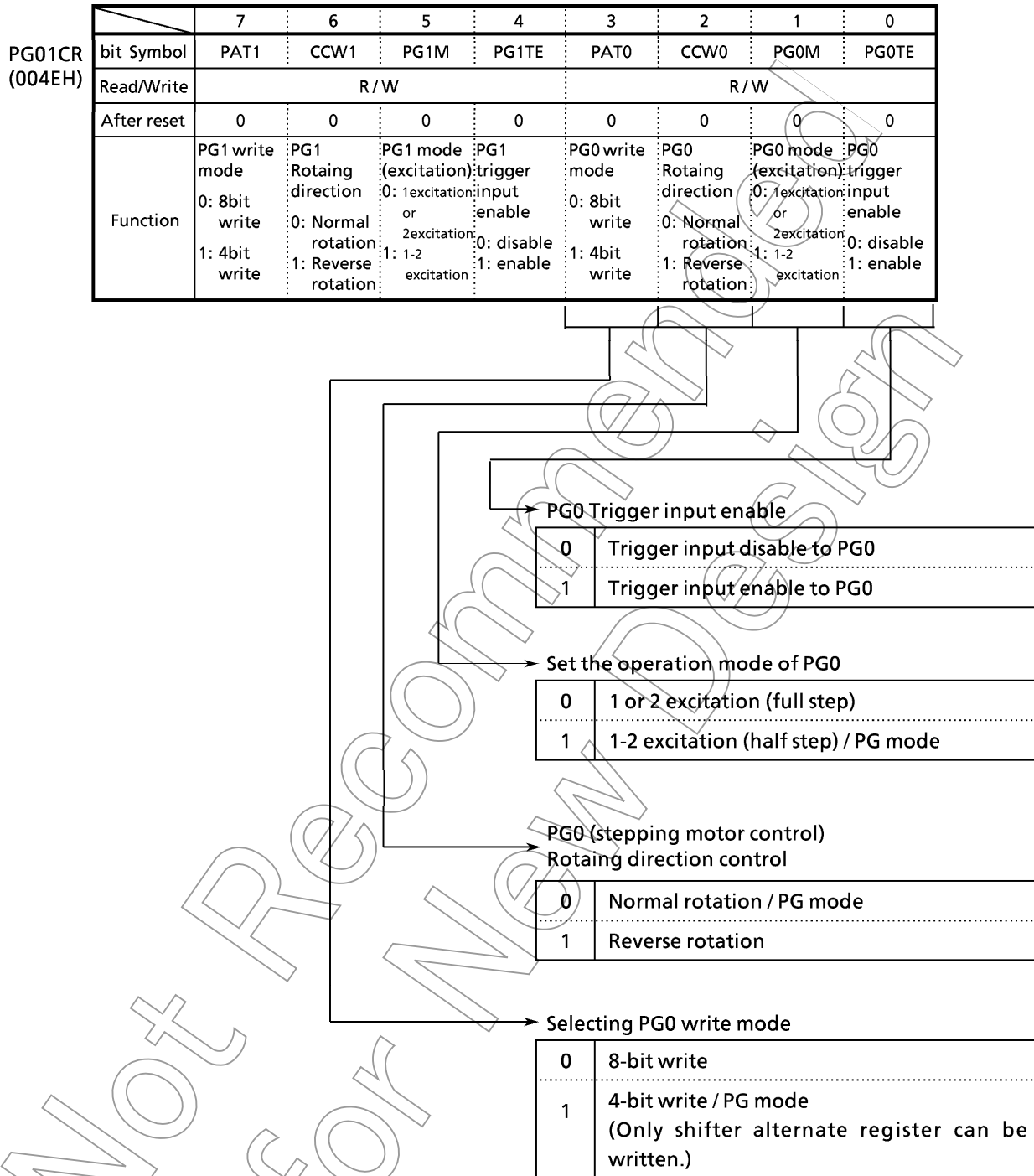

Figure 3.10 (2 a) Pattern Generation Control Register (PG01CR)

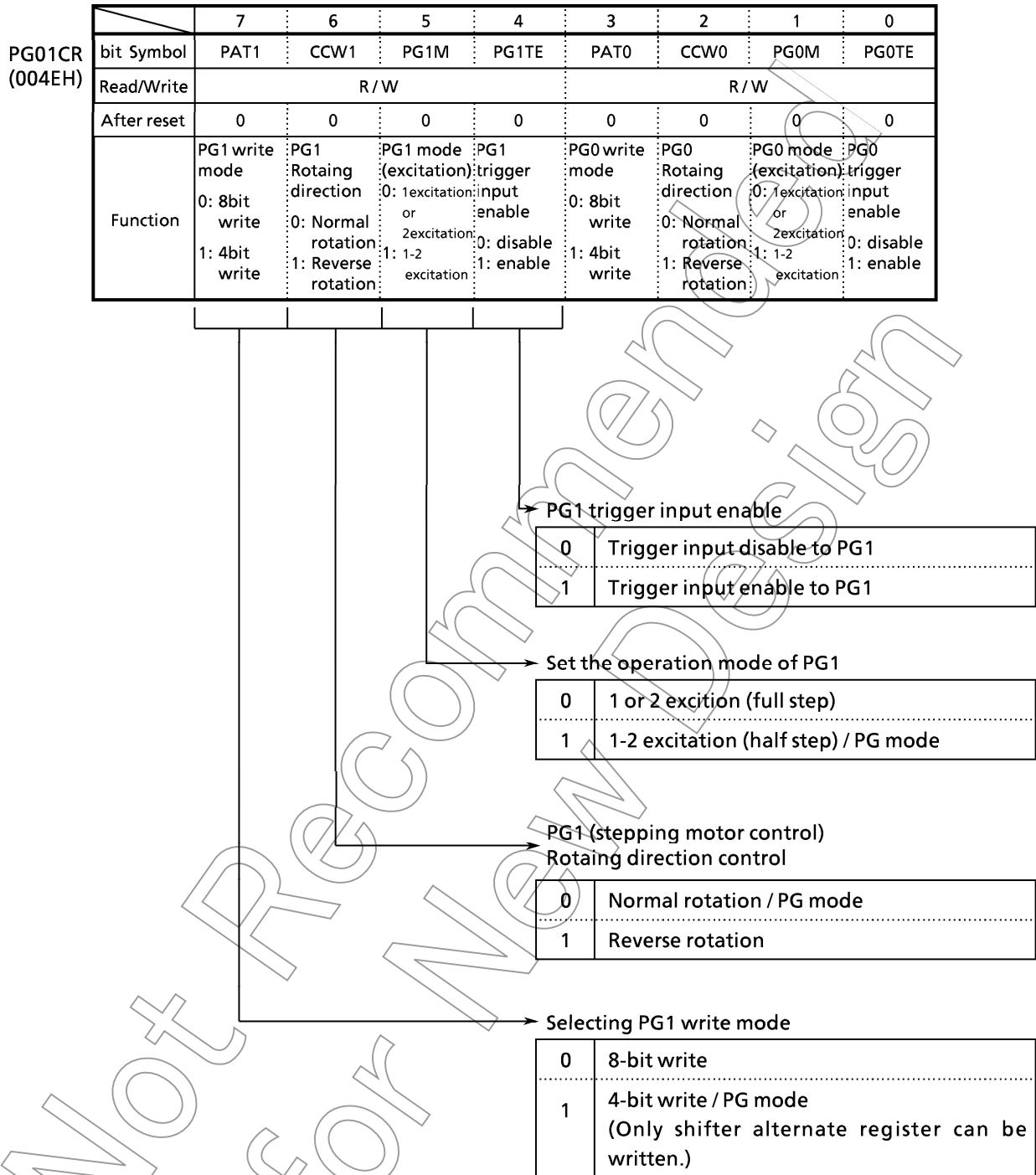

Figure 3.10 (2 b) Pattern Generation Control Register (PG01CR)

		7	6	5	4	3	2	1	0
PG0REG (004CH)	bit Symbol	PG03	PG02	PG01	PG00	SA03	SA02	SA01	SA00
	Read/Write	W				R / W			
	After reset	0	0	0	0	Undefined			
	Function	Pattern Generation 0 (PG0) output latch register (Reading the P6 that is set to the PG port allows to read-out.)				Shift alternate register 0 For the PG mode (4-bit write) register			

Prohibit Read  
modify write

Figure 3.10 (3) Pattern Generation 0 Register (PG0REG)

		7	6	5	4	3	2	1	0
PG1REG (004DH)	bit Symbol	PG13	PG12	PG11	PG10	SA13	SA12	SA11	SA10
	Read/Write	W				R / W			
	After reset	0	0	0	0	Undefined			
	Function	Pattern Generation 1 (PG1) output latch register (Reading the P6 that is set to the PG port allows to read-out.)				Shift alternate register 1 For the PG mode (4-bit write) register			

Prohibit Read  
modify write

Figure 3.10 (4) Pattern Generation 1 Register (PG1REG)

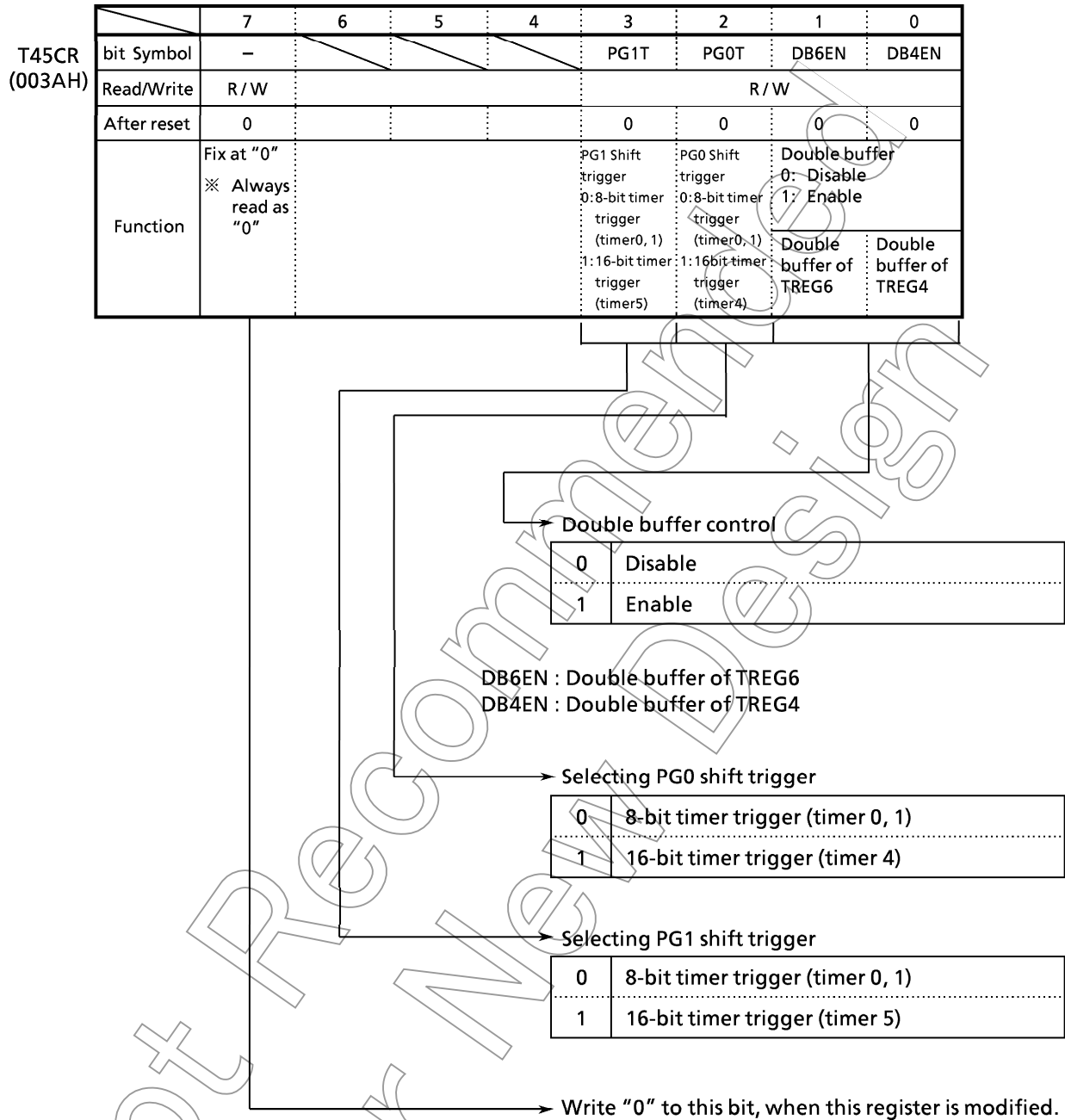

Figure 3.10(5) 16-bit Timer Trigger Control Register (T45CR)

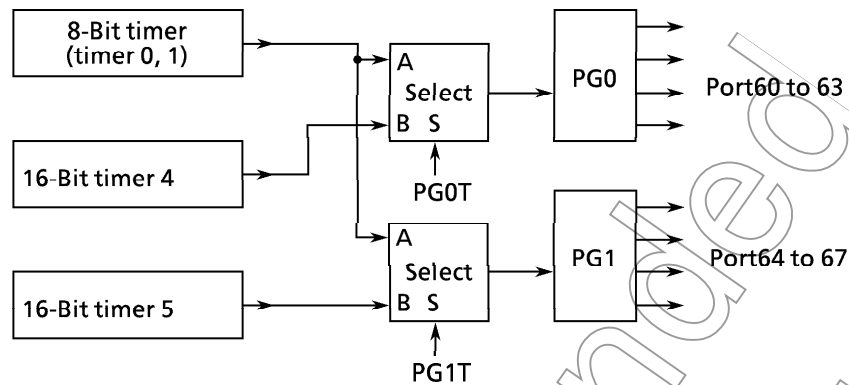

Figure 3.10 (6) Connection of Timer and Pattern Generator

(1) Pattern Generation Mode

PG functions as a pattern generation according to the setting of PG01CR <PAT1> / <PAT0>. In this mode, writing from CPU is executed only on the shifter alternate register. Writing a new data should be done during the interrupt operation of the timer for shift trigger and a pattern can be output, synchronous with the timer.

In this mode, set PG01CR <PG0M> and <PG1M> to 1, and PG01CR <CCW0> and <CCW1> to 0.

The output of this pattern generator is output to port 6 ; since port and functions can be switched on a bit basis using port function control register P6FC, any port pin can be assigned to pattern generator output.

Figure 3.10 (7) shows the block diagram of this mode.

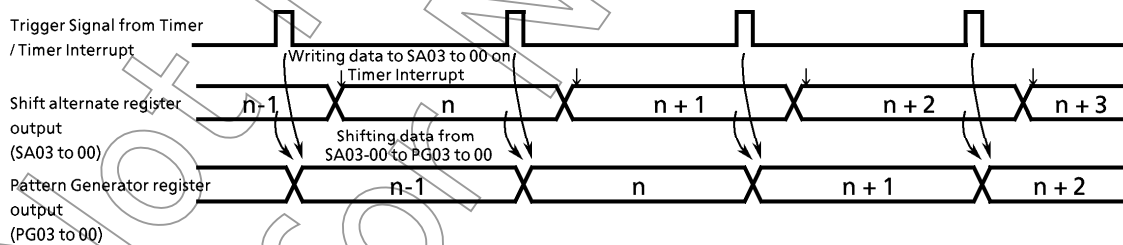

Example of pattern generation mode

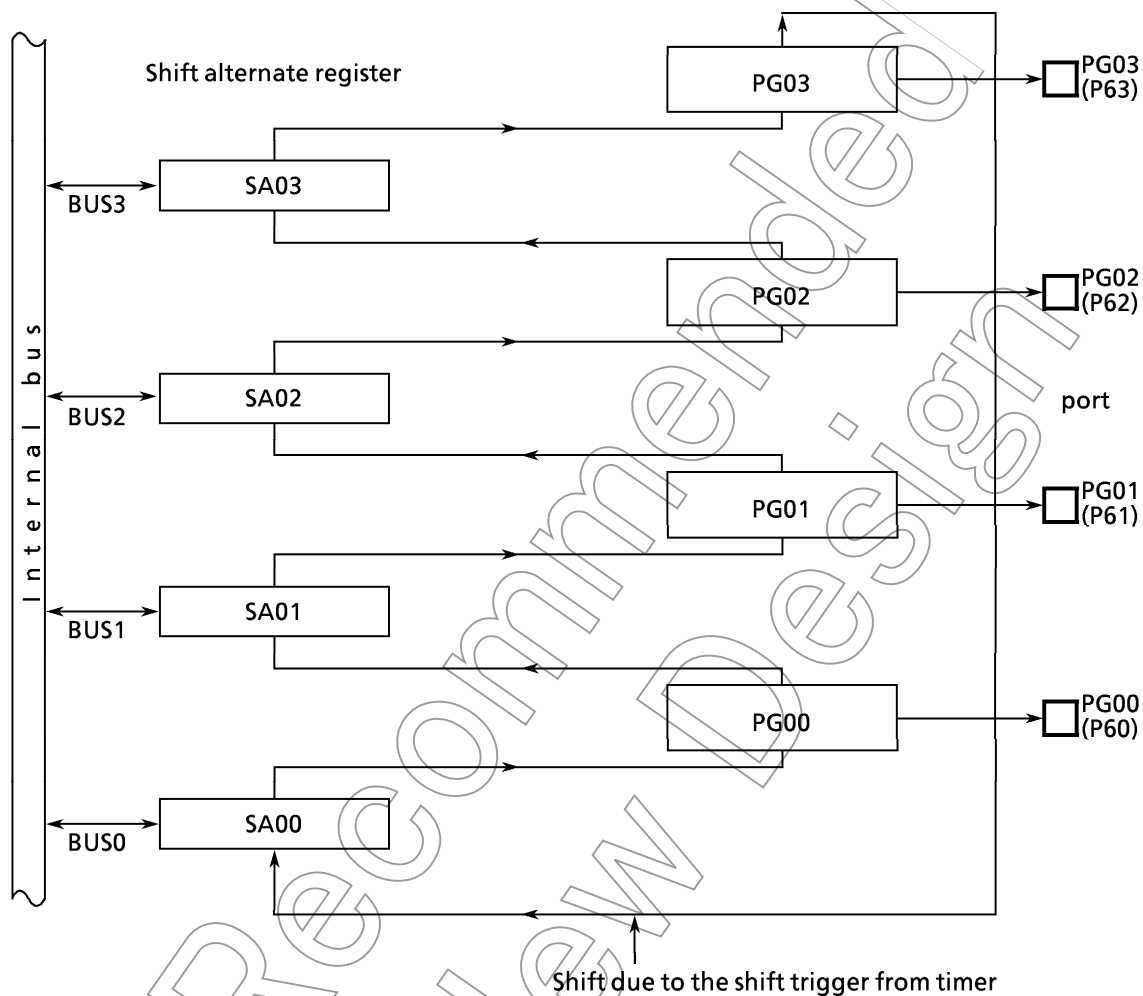

Figure 3.10 (7) Pattern Generation Mode Block Diagram (PG0)

In this pattern generation mode, only writing the output latch is disabled by hardware, but other functions do the same operation as 1-2 excitation in stepping motor control port mode. Accordingly, the data shifted by trigger signal from a timer must be written before the next trigger signal is output.

(2) Stepping Motor Control Mode

① 4-phase 1-Step/2-Step Excitation

Figure 3.10 (8) and Figure 3.10 (9) show the output waveforms of 4-phase 1 excitation and 4-phase 2 excitation, respectively when channel 0 (PG0) is selected.

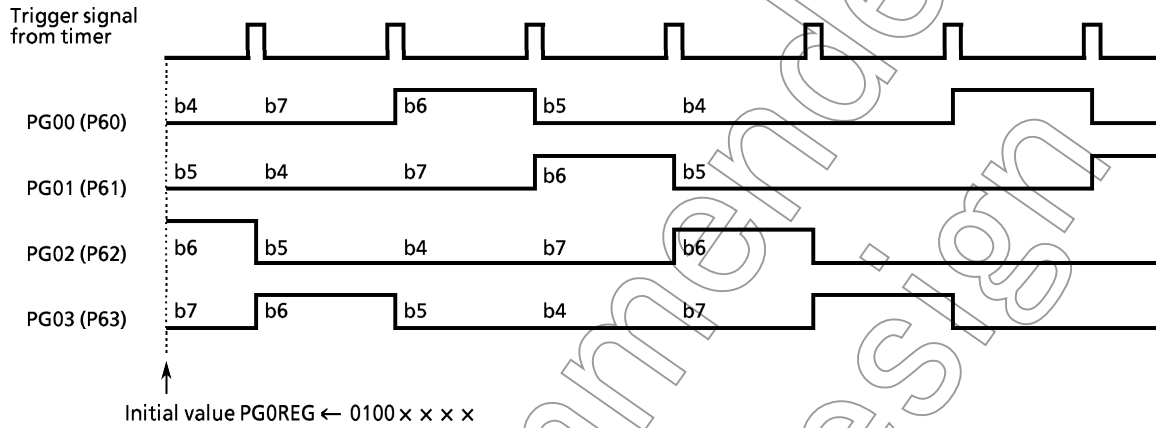

Note : bn indicates the initial value of PG0REG ← b7 b6 b5 b4 x x x x

① Normal Rotation

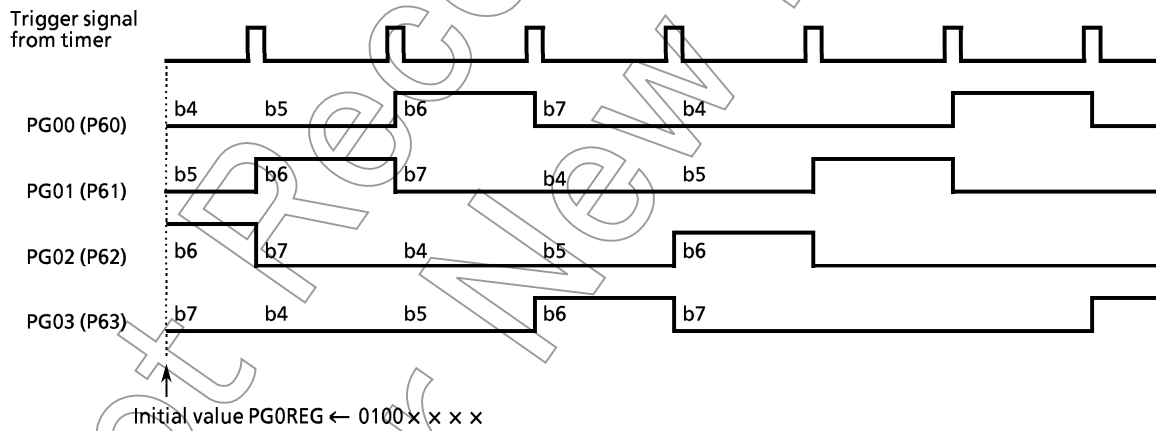

② Reverse Rotation

010289

Figure 3.10 (8) Output Waveforms of 4-Phase 1-step Excitation (Normal Rotation and Reverse Rotation)



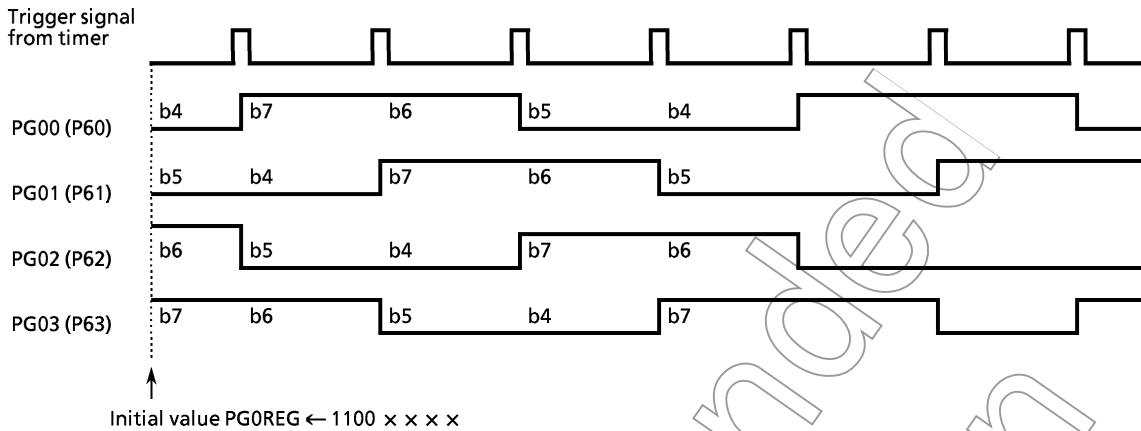

Figure 3.10 (9) Output Waveforms of 4-Phase 2-step Excitation (Normal Rotation)

The operation when channel 0 is selected is explained below.

The output latch of PG0 (also used as P6) is shifted at the rising edge of the trigger signal from the timer to be output to the port.

The direction of shift is specified by PG01CR<CCW0>: Normal rotation (PG00→PG01→PG02→PG03) when <CCW0> is set to “0”; reverse rotation (PG00←PG01←PG02←PG03) when “1”. 4-phase 1-step excitation will be selected when only one bit is set to “1” during the initialization of PG, while 4-phase 2-step excitation will be selected when two consecutive bits are set to “1”.

The value in the shift alternate registers are ignored when the 4-phase 1-step/2-step excitation mode is selected.

Figure 3.10 (10) shows the block diagram.

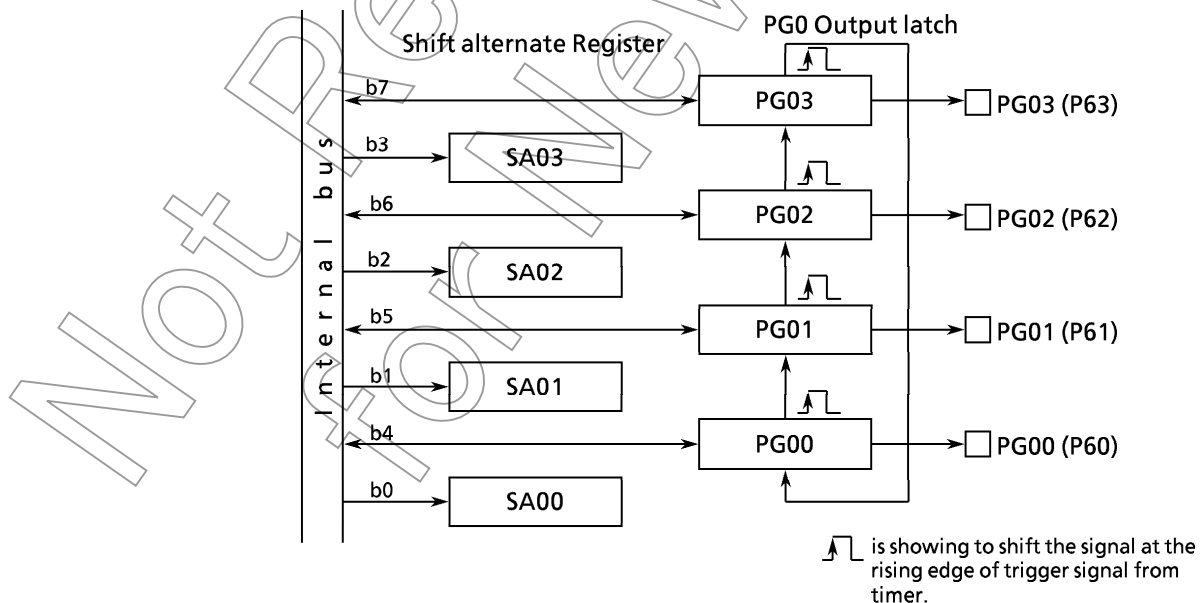
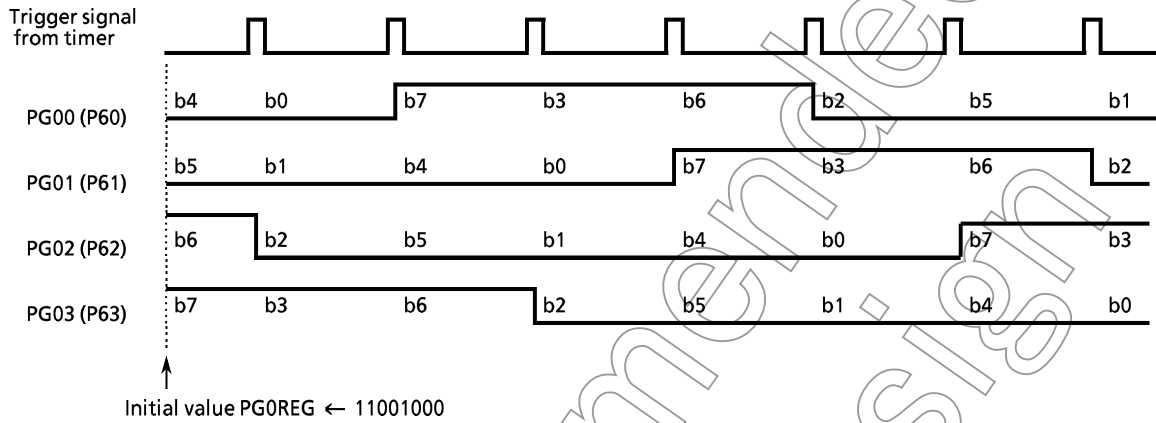

Figure 3.10 (10) Block Diagram of 4-Phase 1-step Excitation/2-step Excitation (Normal Rotation)

② 4-Phase 1-2 step Excitation

Figure 3.10 (11) shows the output waveforms of 4-phase 1-2 step excitation when channel 0 is selected.



Note: bn denotes the initial value PGOREG ← b7 b6 b5 b4 b3 b2 b1 b0

① Normal Rotation

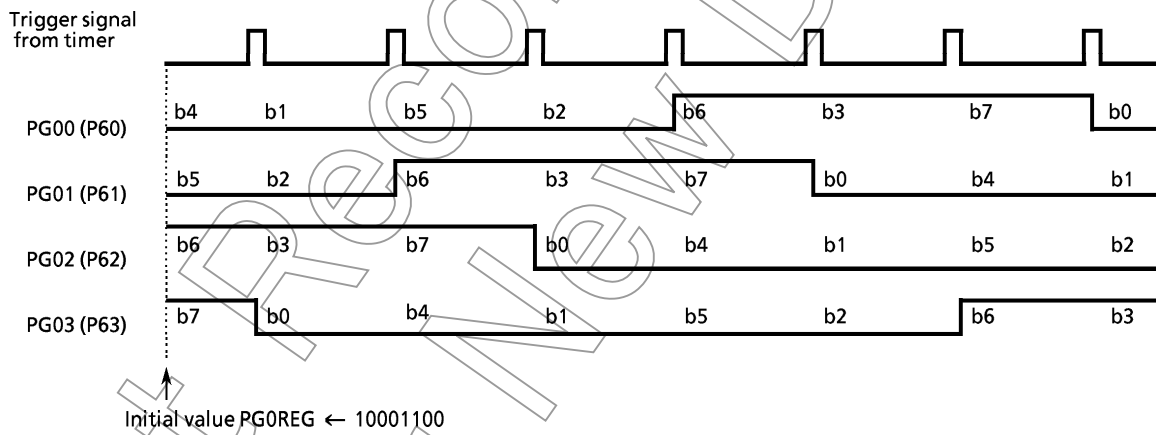

② Reverse Rotation

Figure 3.10 (11) Output Waveforms of 4-Phase 1-2 step Excitation (Normal Rotation and Reverse Rotation)

The initialization for 4-phase 1-2 step excitation is as follows.

By rearranging the initial value “b7 b6 b5 b4 b3 b2 b1 b0” to “b7 b3 b6 b2 b5 b1 b4 b0”, the consecutive 3 bits are set to “1” and other bits are set to “0” (positive logic).

For example, if b7, b3, and b6 are set to “1”, the initial value becomes “11001000”, obtaining the output waveforms as shown in Figure 3.10 (11).

To get an output waveform of negative logic, set values 1’s and 0’s of the initial value should be inverted. For example, to change the output waveform shown in Figure 3.10 (11) into negative logic, change the initial value to “00110111”.

The operation will be explained below for channel 0.

The output latch of PG0 (shared by P6) and the shifter alternate register (SA0) for Pattern Generation are shifted at the rising edge of trigger signal from the timer to be output to the port. The direction of shift is set by PG01CR <CCW0>.

Figure 3.10 (12) shows the block diagram.

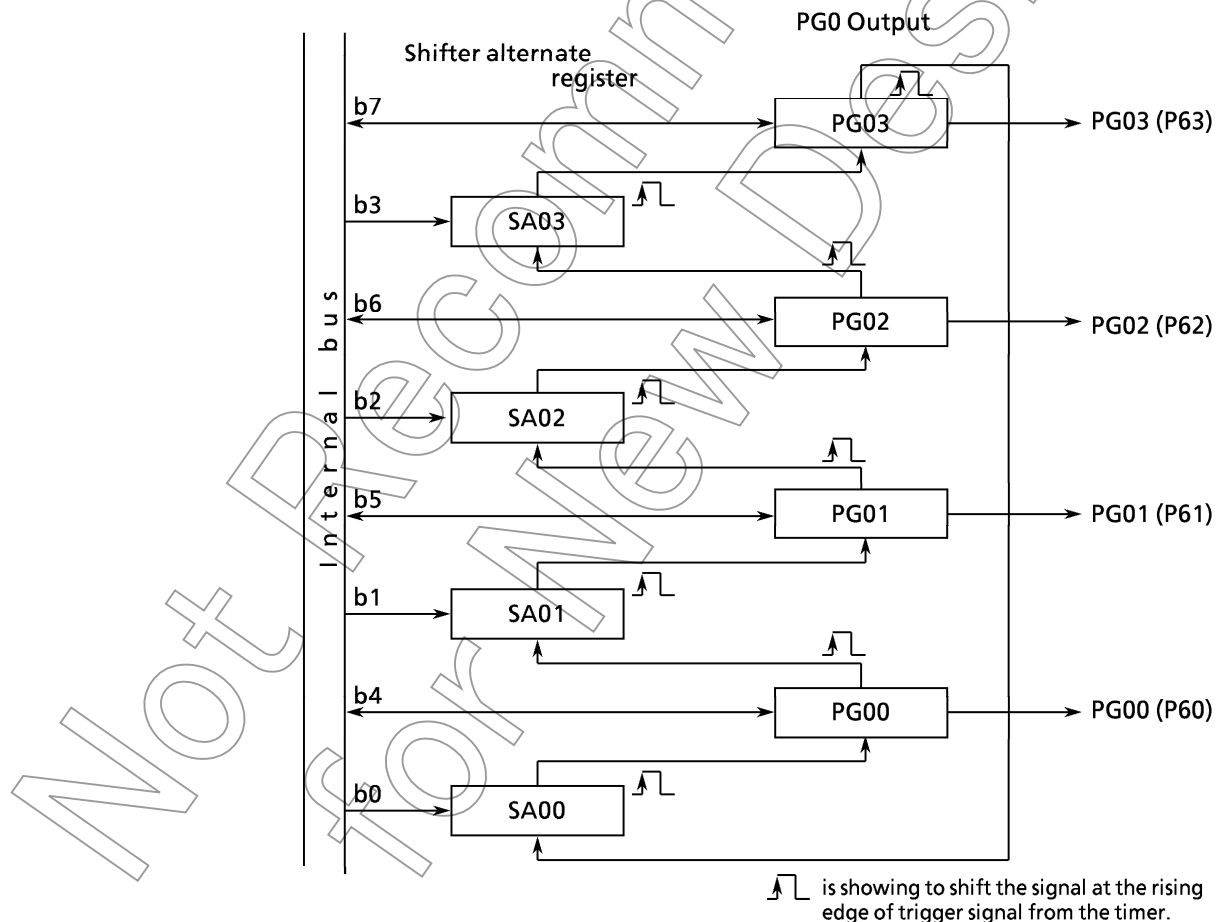

Figure 3.10 (12) Block Diagram of 4-Phase 1-2 step Excitation (Normal Rotation)

Setting example: To drive channel 0 (PG0) by 4-phase 1-2 step excitation (normal rotation) when timer 0 is selected, set each register as follows.

	7 6 5 4 3 2 1 0	
TRUN	← - X - - - - 0	Stop timer 0, and clear it to zero.
TMOD	← 0 0 X X - - 0 1	Set 8-bit timer mode and select $\phi$ T1 as the input clock of timer 0.
TFFCR	← X X X 0 1 0 1 0	Clear TFF1 to zero and enable the inversion trigger by timer 0.
TREG0	← * * * * * * * *	Set the cycle in timer register.
P6CR	← - - - - 1 1 1 1	Set P60~P63 bits to the output mode.
P6FC	← - - - - 1 1 1 1	Set P60~P63 bits to the PG output.
PG01CR	← - - - - 0 0 1 1	Select PG0 4-phase 1-2 step excitation mode and normal rotation .
PGOREG	← 1 1 0 0 1 0 0 0	Set an initial value.
TRUN	← 1 X - - - - - 1	Start timer 0.

Note: X; Don't care - ; No change

(3) Trigger Signal From Timer

The trigger signal from the timer which is used by PG is not equal to the trigger signal of timer flip-flop (TFF1, TFF4, TFF5, and TFF6) and differs as shown in Table 3.10 (1) depending on the operation mode of the timer.

Table 3.10 (1) Select of Trigger Signal

	TFF1 inversion	PG shift
8-bit timer mode	Selected by TFFCR <TFF1IS> when the up-counter value matches TREG0 or TREG1 value.	←
16-bit timer mode	When the up-counter value matches with both TREG0 and TREG1 values (The value of up-counter = $TREG1 * 2^8 + TREG0$ )	←
PPG output mode	When the up-counter value matches with both TREG0 and TREG1	When the up-counter value matches TREG1 value (PPG cycle)
PWM output mode	When the up-counter value matches TREG0 value and PWM cycle.	Trigger signal for PG is not generated.

Note: To shift PG, TFFCR <TFF1IE> must be set to "1" to enable TFF1 inversion.

Channel 1 of PG can be synchronized with the 16-bit timer Timer4/Timer5. In this case, the PG shift trigger signal from the 16-bit timer is output only when the up-counter UC4 / UC5 value matches TREG5/TREG7.

When using a trigger signal from Timer4, set either T4FFCR<EQ5T4> or T4MOD <EQ5T5> to “1” and a trigger is generated when the value in UC4 and the value in TREG5 match. When using a trigger signal from Timer5, set T5FFCR<EQ7T6> to 1. Generates a trigger when the value in UC5 and the value in TREG7 match.

(4) Application of PG and Timer Output

As explained “Trigger signal from timer”, the timing to shift PG and invert TFF differs depending on the mode of timer. An application to operate PG while operating an 8-bit timer in PPG mode will be explained below.

To drive a stepping motor, in addition to the value of each phase (PG output), synchronizing signal is often required at the timing when excitation is changed over. In this application, port 6 is used as a stepping motor control port to output a synchronizing signal to the TO1 pin (shared by P71).



Figure 3.10 (13) Output Waveforms of 4-Phase 1-step Excitation

Setting example:

	7	6	5	4	3	2	1	0		
TRUN	←	-	X	-	-	-	-	0	0	Stop timer 0, and clear it to zero.
TMOD	←	1	0	X	X	X	X	0	1	Set timer 0 and timer 1 in PPG output mode and select φT1 as the input clock.
TFFCR	←	X	X	X	0	0	1	1	X	Enable TFF1 inversion and set TFF1 to “1”.
TREG0	←	*	*	*	*	*	*	*	*	Set the duty of TO1 to TREG0.
TREG1	←	*	*	*	*	*	*	*	*	Set the cycle of TO1 to TREG1.
P7CR	←	X	X	X	X	-	-	1	-	} Assign P71 as TO1.
P7FC	←	X	X	X	X	-	-	1	X	
P6CR	←	-	-	-	-	1	1	1	1	} Assign P60 to 63 as PG0.
P6FC	←	-	-	-	-	1	1	1	1	
PG01CR	←	-	-	-	-	0	0	0	1	Set PG0 in 4-phase 1-step excitation mode.
PGOREG	←	*	*	*	*	*	*	*	*	Set an initial value.
TRUN	←	1	X	-	-	-	-	1	1	Start timer 0 and timer 1.

Note: X; Don't care    - ; No change

3.11 Serial ChannelA

TMP96C141B contains 2 serial I/O channels for full duplex universal asynchronous receiver transmission (UART) as well as for I/O extension (I/O interface mode). Channel 1 cannot control  $\overline{CTS}$  pin.

The serial channel has the following operation modes.

- I/O interface mode (channel 0 and 1)
  - Mode 0: For receiving and transmitting I/O data for I/O extension, and for receiving and transmitting synchronous I/O data signals (SCLK).
- Universal asynchronous receiver transmitter (UART) mode (channel 0 and 1)
  - Mode 1: 7-bit transmit/receive data
  - Mode 2: 8-bit transmit/receive data
  - Mode 3: 9-bit transmit/receive data

In mode 1 and mode 2, a parity bit can be added. Mode 3 has wake-up function for making the master controller start slave controllers in serial link (multi-controller system).

Figure 3.11 (1) shows the data format (for one frame) in each mode.

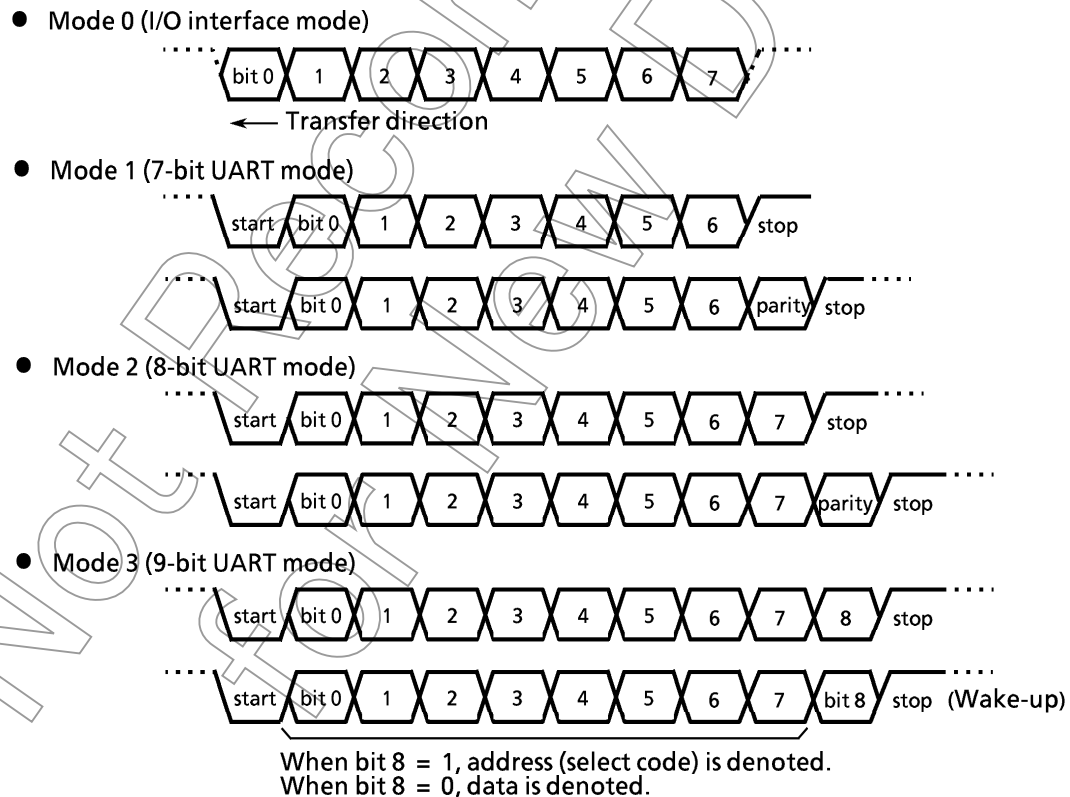

Figure 3.11 (1) Data Formats

The serial channel has a buffer register for transmitting and receiving operations, in order to temporarily store transmitted or received data, so that transmitting and receiving operations can be done independently (full duplex).

However, in I/O interface mode, SCLK (serial clock) pin is used for both transmission and receiving, the channel becomes half-duplex.

The receiving data register is of a double buffer structure to prevent the occurrence of overrun error and provides one frame of margin before CPU reads the received data. The receiving data register stores the already received data while the buffer register receives the next frame data.

By using CTS and RTS (there is no RTS pin, so any 1 port must be controlled by software), it is possible to halt data send until the CPU finishes reading receive data every time a frame is received. (Handshake function)

In the UART mode, a check function is added not to start the receiving operation by error start bits due to noise. The channel starts receiving data only when the start bit is detected to be normal at least twice in three samplings.

When the transmission buffer becomes empty and requests the CPU to send the next transmission data, or when data is stored in the receiving data register and the CPU is requested to read the data, INTTX or INTRX interrupt occurs. Besides, if an overrun error, parity error, or framing error occurs during receiving operation, flag SC0CR/SC1CR < OERR, PERR, FERR > will be set.

The serial channel 0/1 includes a special baud rate generator, which can set any baud rate by dividing the frequency of 4 clocks ( $\phi T0$ ,  $\phi T2$ ,  $\phi T8$ , and  $\phi T32$ ) from the internal prescaler (shared by 8-bit/16-bit timer) by the value 2 to 16.

In I/O interface mode, it is possible to input synchronous signals as well as to transmit or receive data by external clock.

### 3.11.1 Control Registers

The serial channel is controlled by 3 control registers SC0CR, SC0MOD and BR0CR. Transmitted and received data are stored in register SC0BUF.

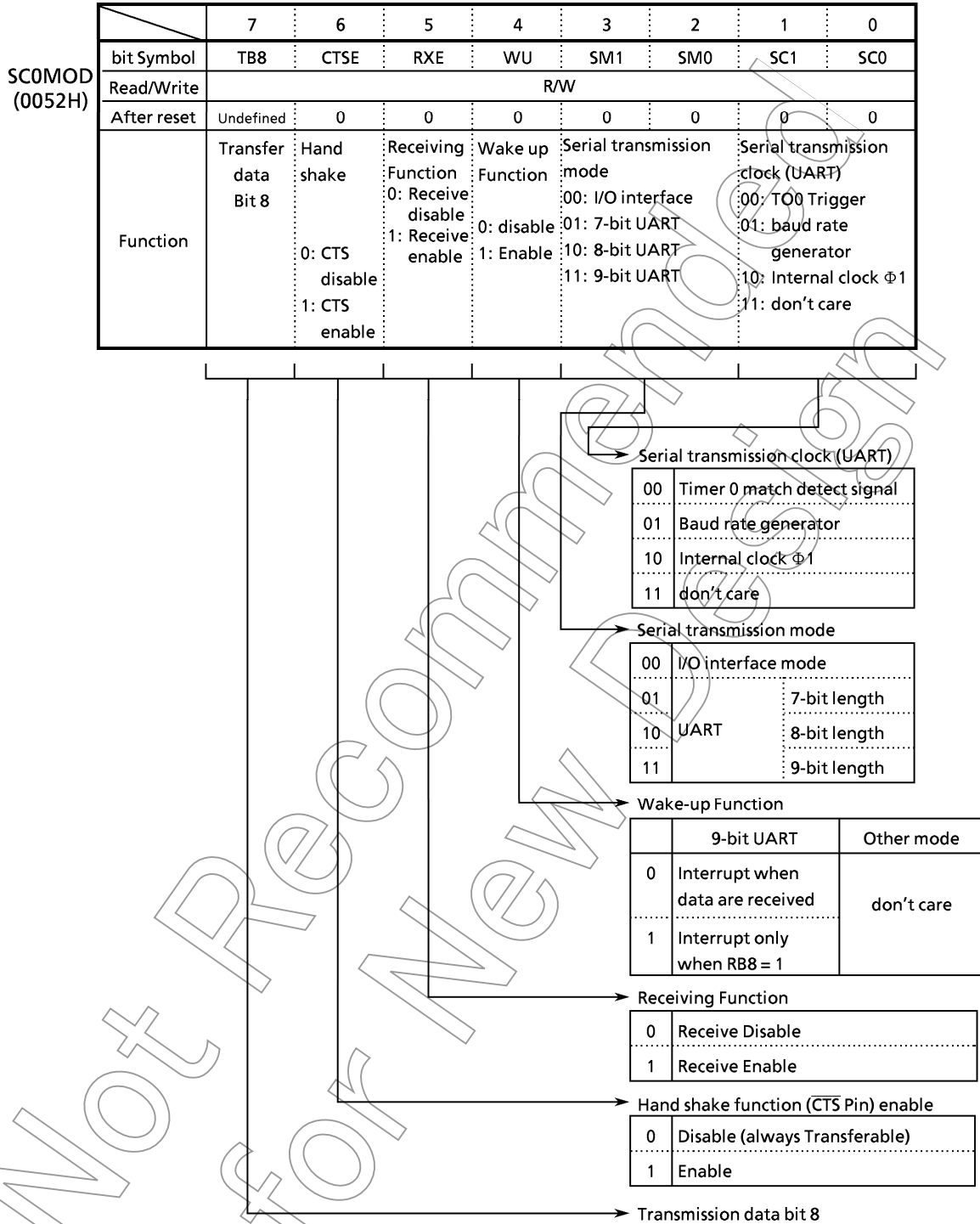

Note : There is SC1MOD (56H) in Channel1

Figure 3.11 (2) Serial Mode Control Register (channel 0, SC0MOD)



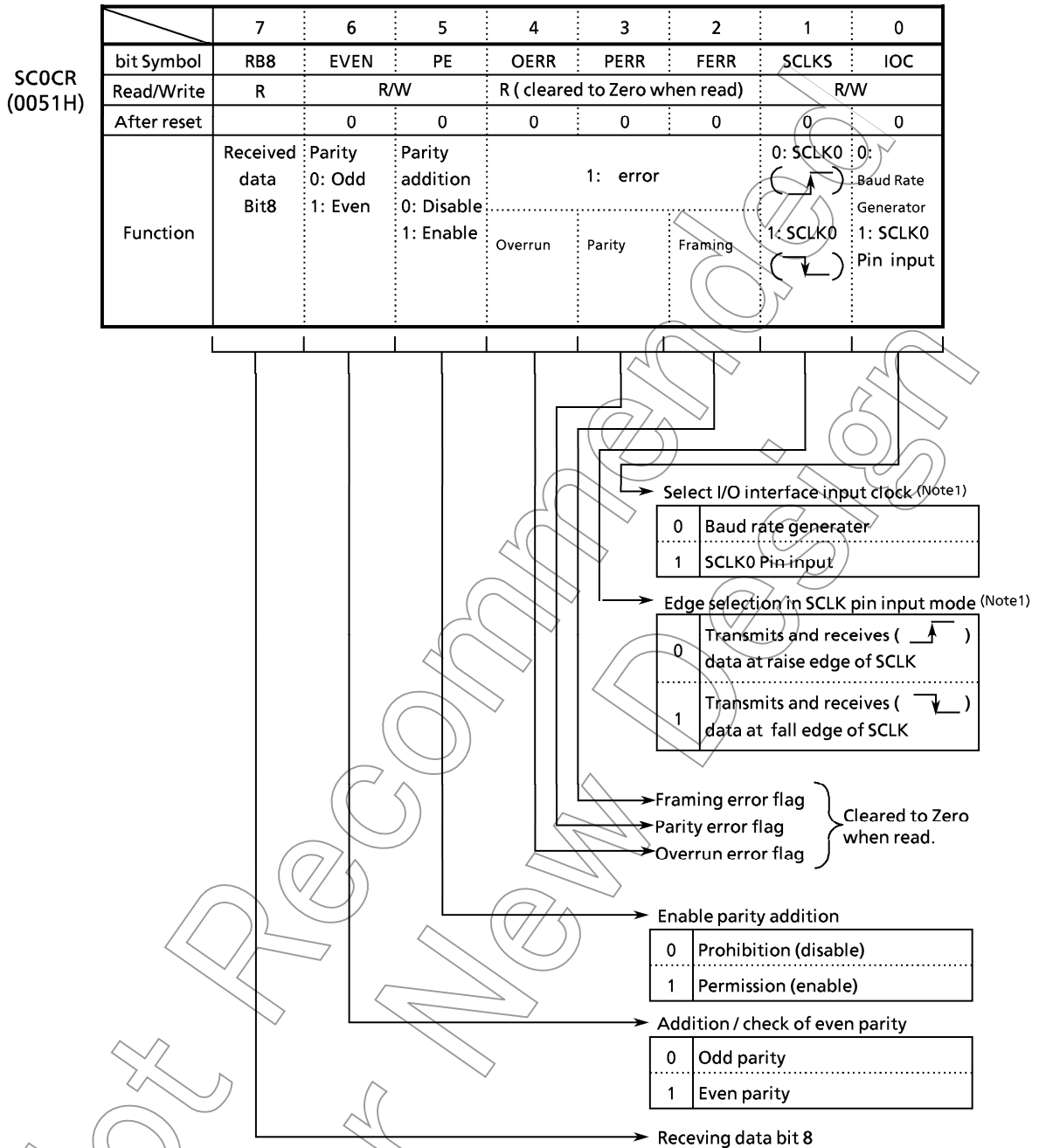

Note : Serial control register for channel 1 is SC1CR (55H).

Note : As all error flags are cleared after reading do not test only a single bit with a bit-testing instruction.

Figure 3.11 (3) Serial Control Register (channel, SC0CR)

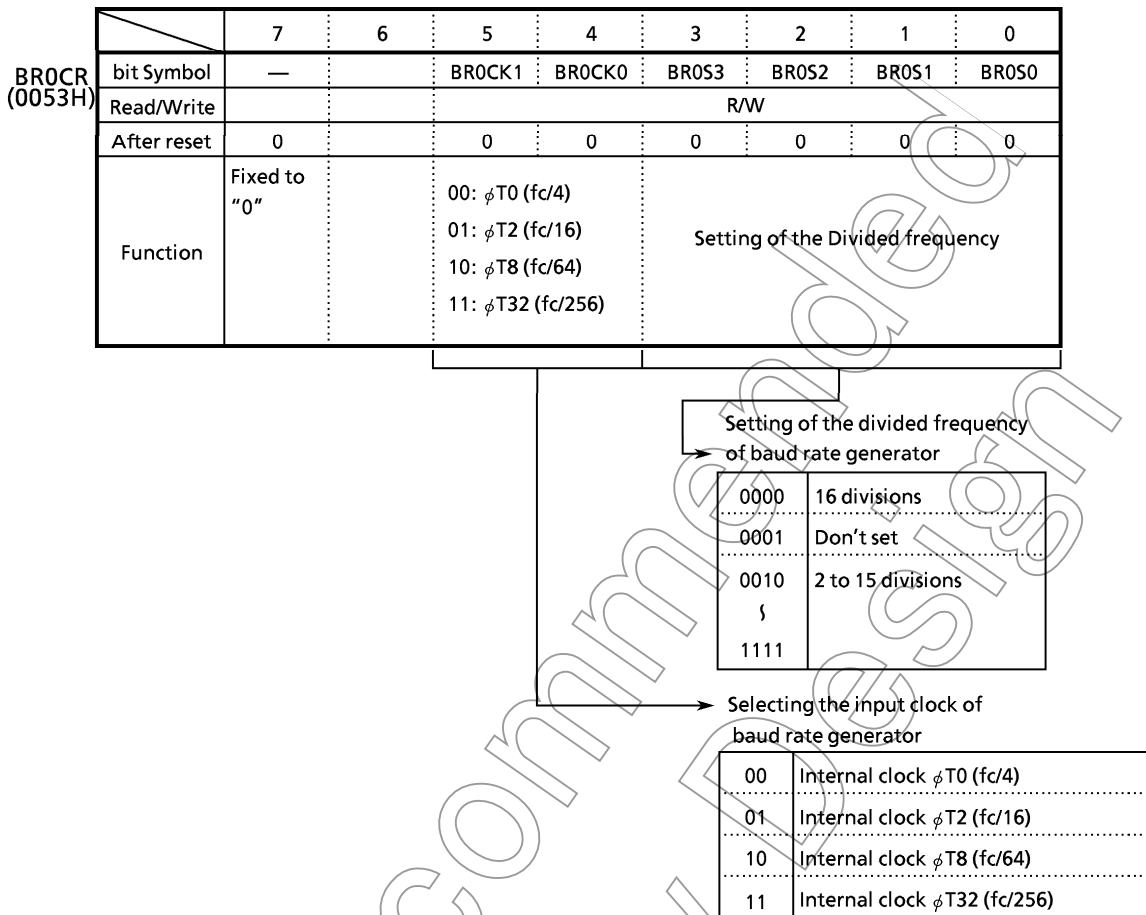

- Note :
- Set TRUN < PRRUN > to "1" when the baud rate generator is used.
  - Don't read from or write to BR0CR register during sending or receiving.

Figure 3.11 (4) Serial Channel Control (channel 0, BR0CR)

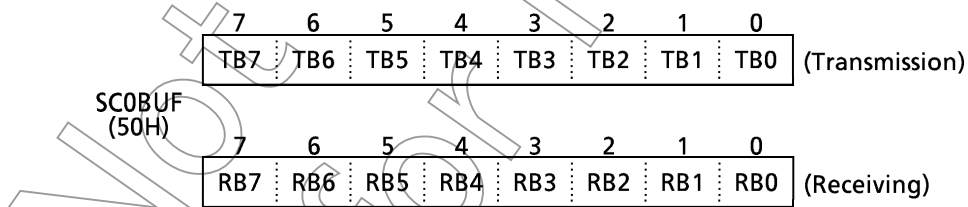

Figure 3.11 (5) Serial Transmission / Receiving Buffer Registers (channel 0, SC0BUF)

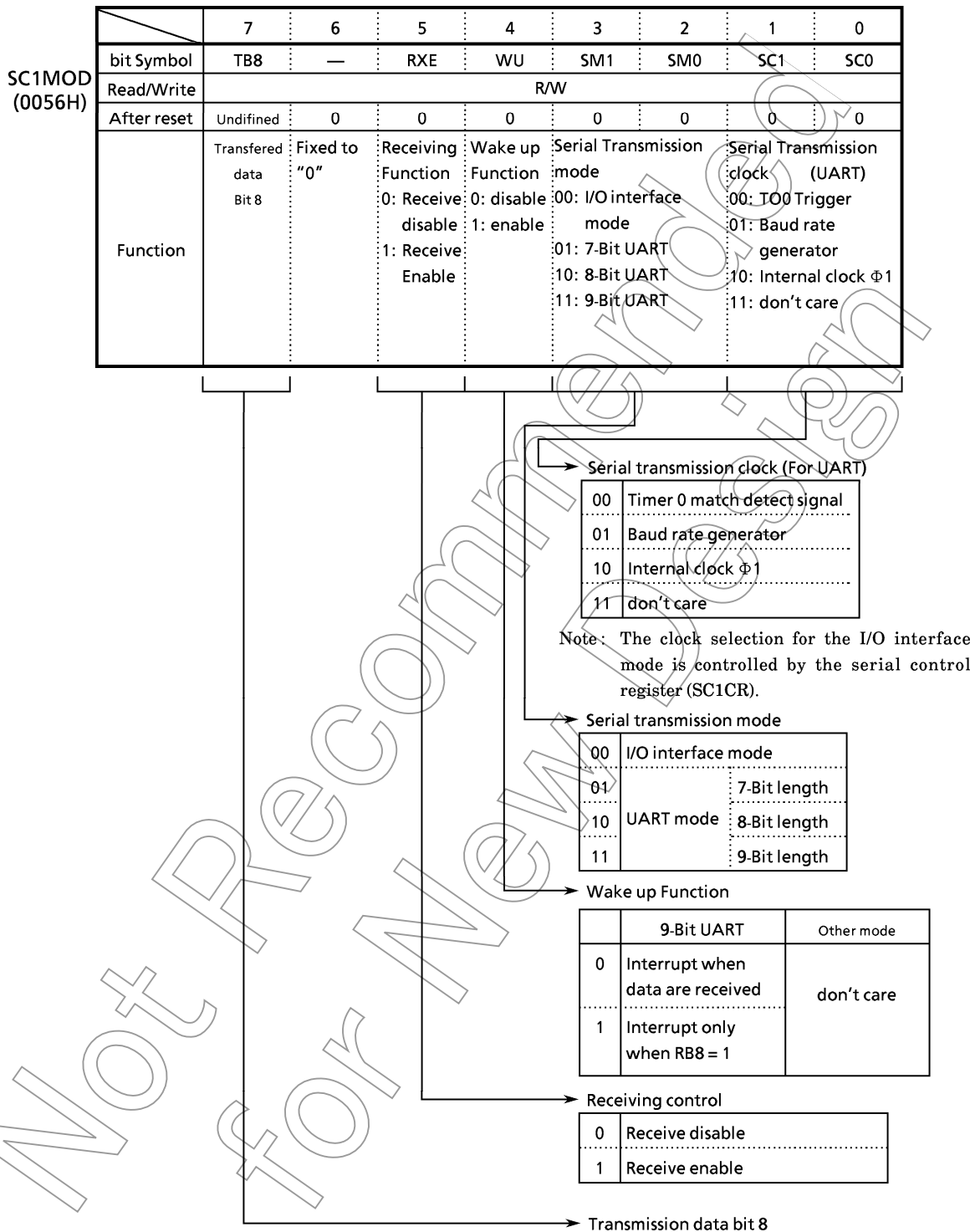
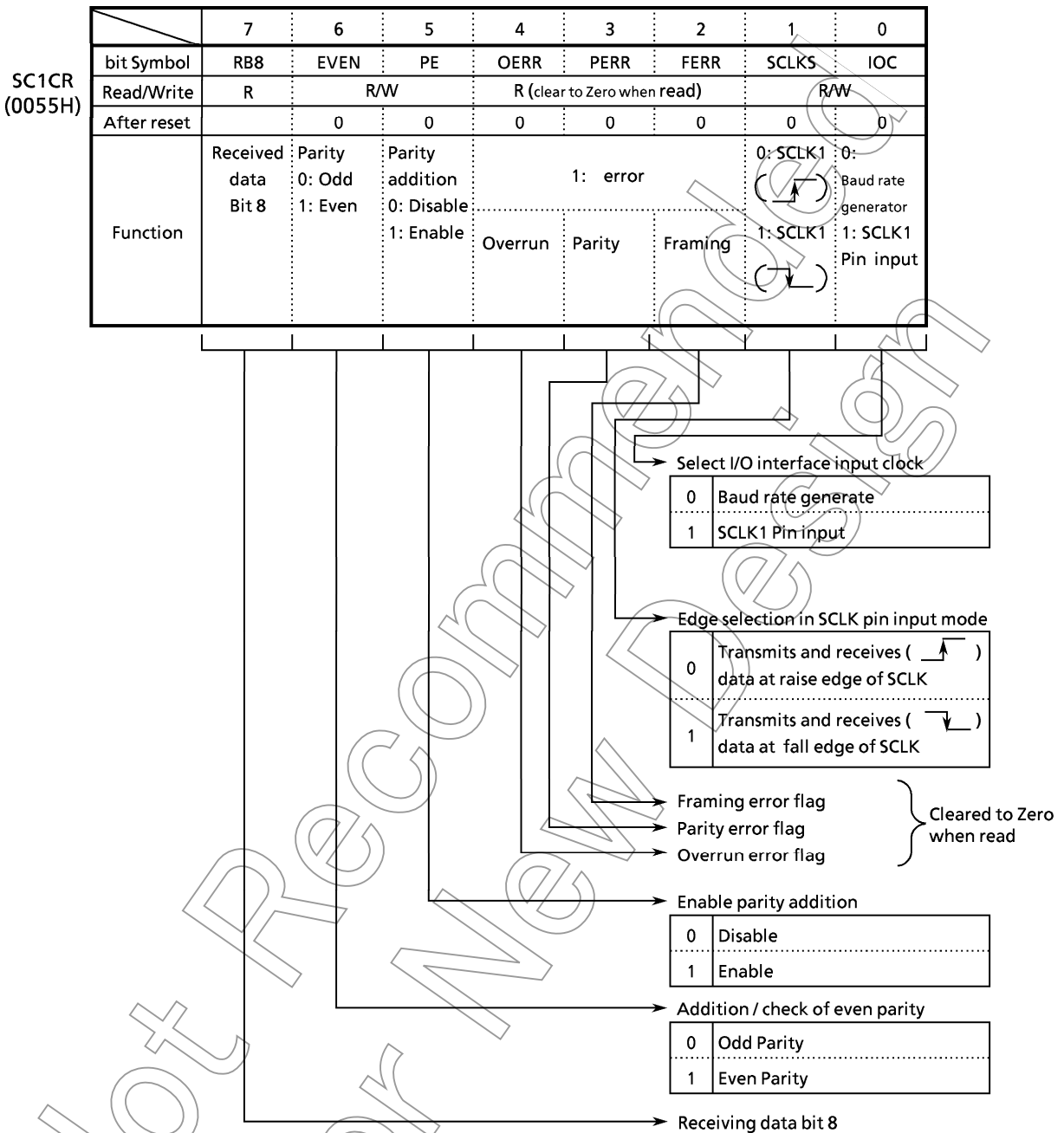
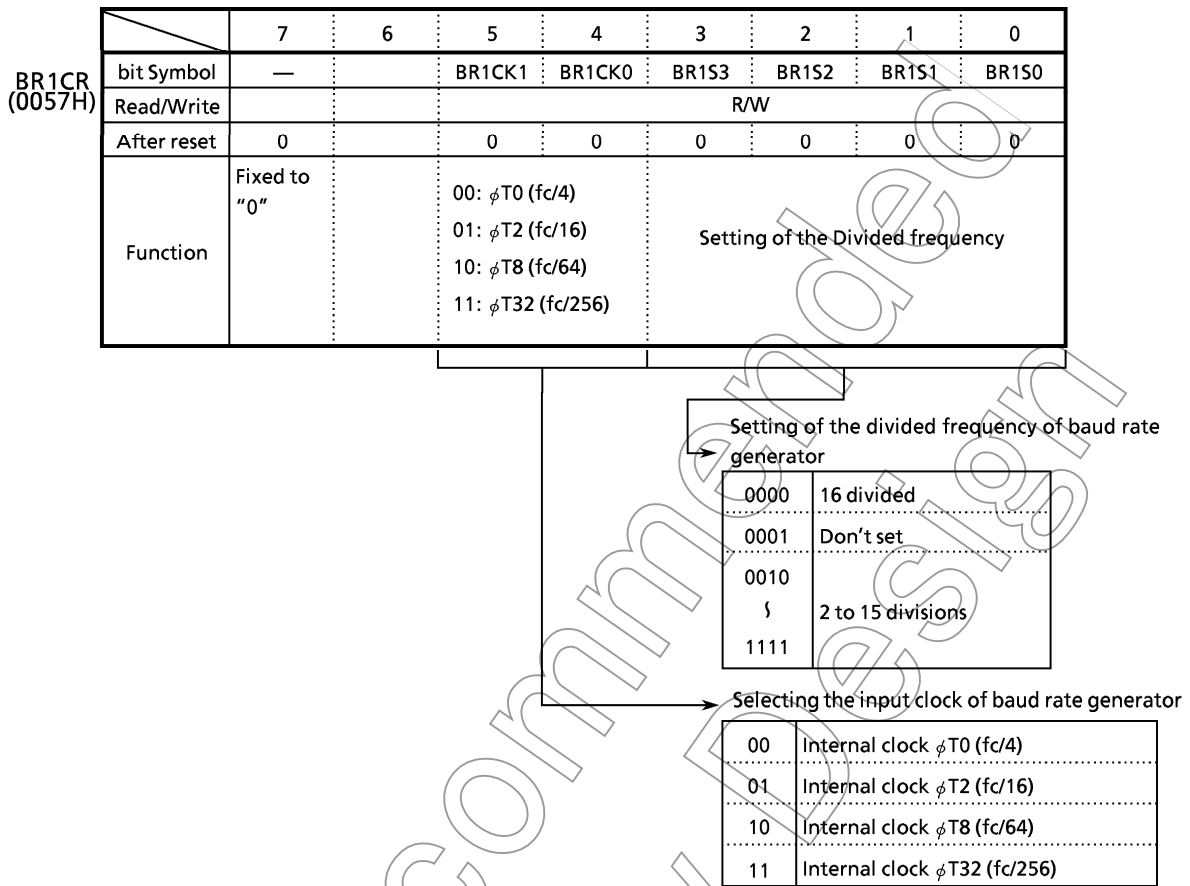

Figure 3.11 (6) Serial Mode Control Register (Channel 1, SC1MOD)



Note : As all error flags are cleared after reading, do not test only a single bit with a bit-testing instruction.

Figure 3.11 (7) Serial Control Register (Channel 1, SC1CR)



- Note :
- To use baud rate generator, set TRUN < PRRUN > to "1", putting the prescaler in RUN mode.
  - Don't read from or write to BR1CR register during sending or receiving.

Figure 3.11 (8) Baud Rate Generator Control Register (channel 0, BR0CR)

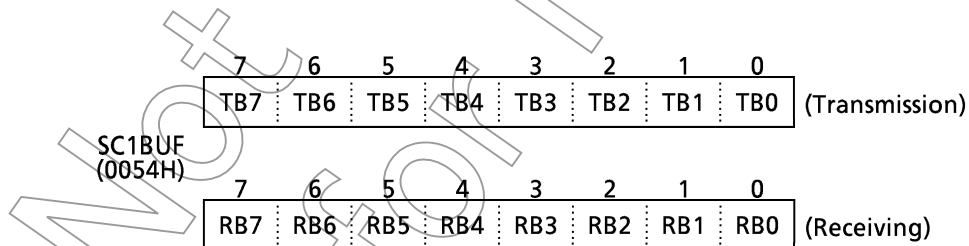

Figure 3.11 (9) Serial Transmission / Receiving Buffer Registers (channel 1, SC1BUF)

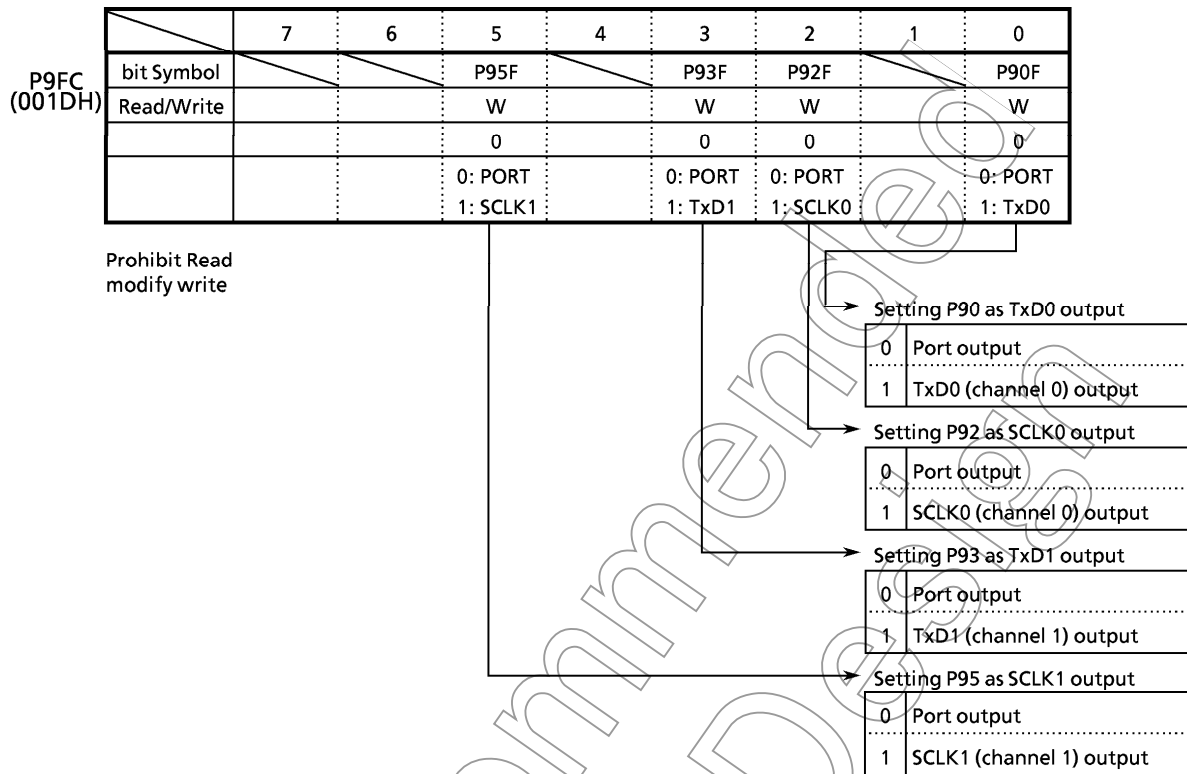

Figure 3.11 (10) Port 9 Function Register (P9FC)

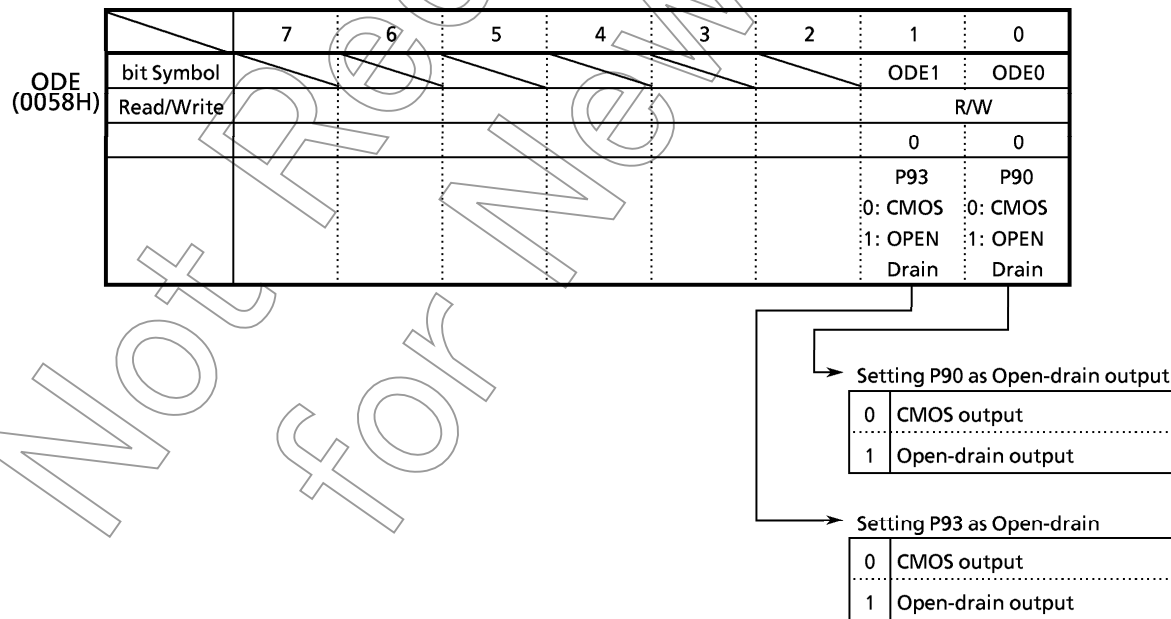

Figure 3.11 (11) Port 9 Open Drain Enable Register (ODE)

3.11.2 Configuration

Figure 3.11 (12) shows the block diagram of the serial channel 0.

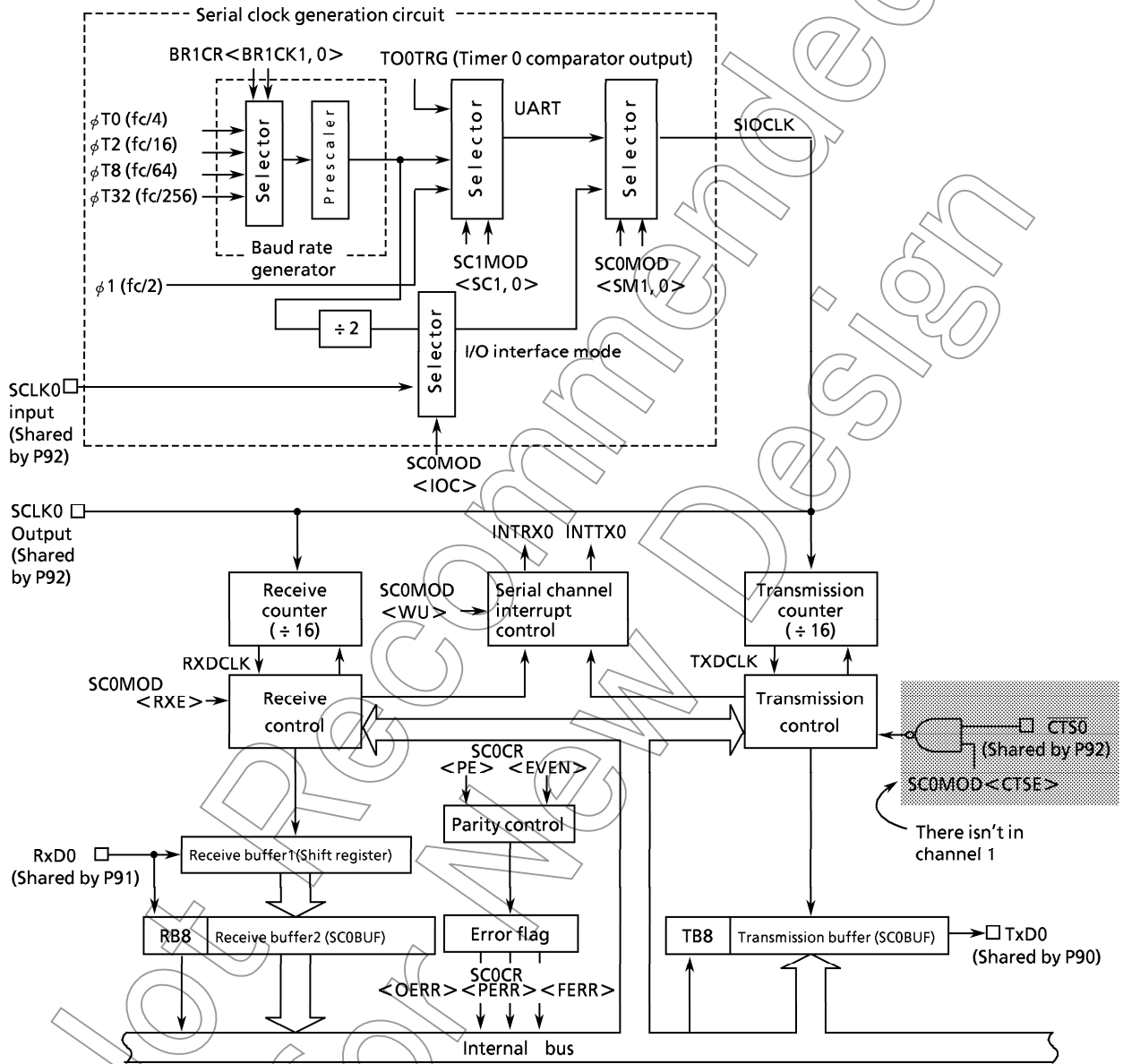

Figure 3.11 (12) Block Diagram of the Serial Channel 0

Figure 3.11 (13) shows the block diagram of the serial channel 1.

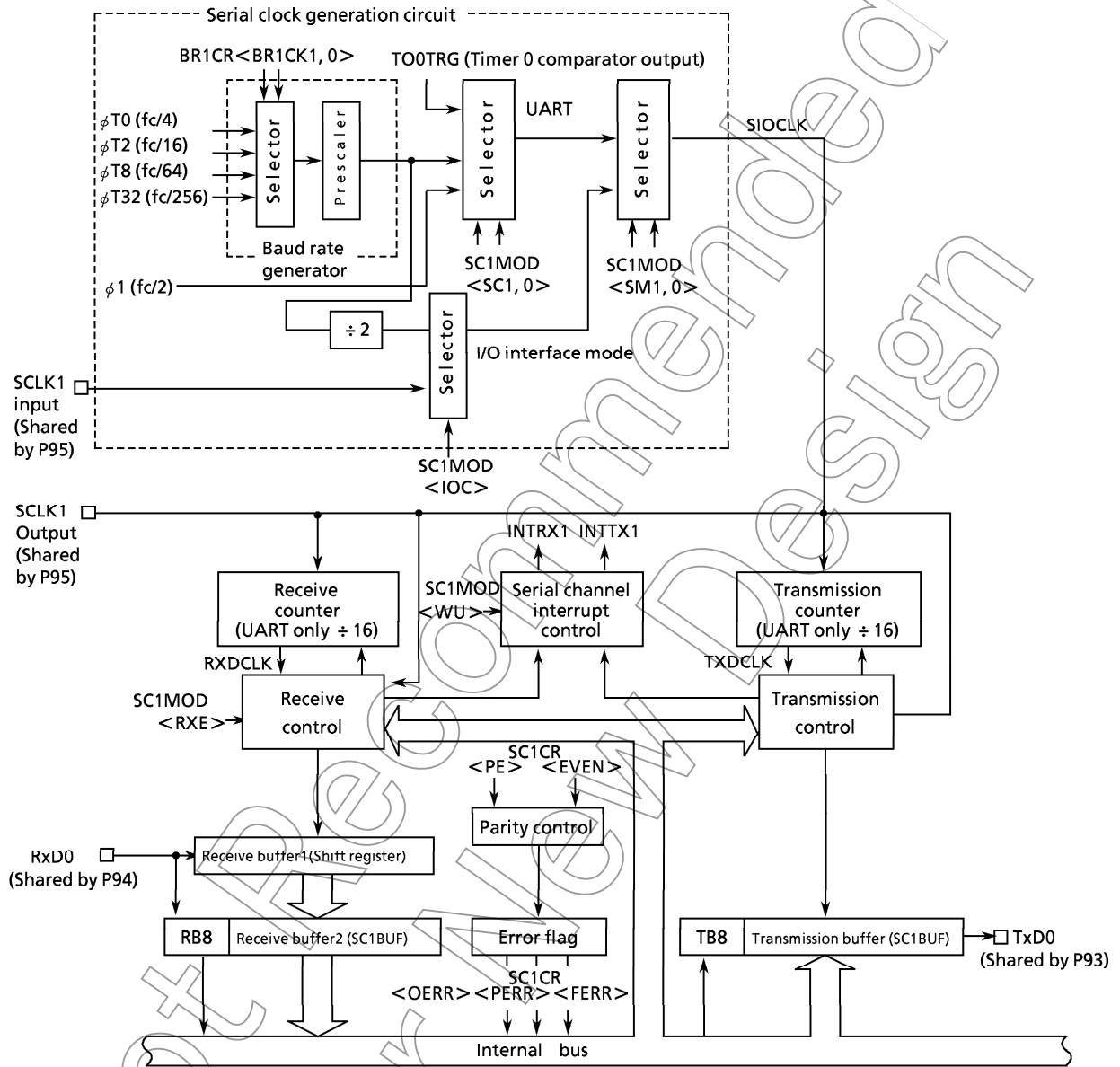

Figure 3.11 (13) Block Diagram of the Serial Channel 1



## ① Baud Rate Generator

Baud rate generator comprises a circuit that generates transmission and receiving clocks to determine the transfer rate of the serial channel.

The input clock to the baud rate generator,  $\phi T0$  ( $fc/4$ ),  $\phi T2$  ( $fc/16$ ),  $\phi T8$  ( $fc/64$ ), or  $\phi T32$  ( $fc/256$ ) is generated by the 9-bit prescaler which is shared by the timers. One of these input clocks is selected by the baud rate generator control register  $BR0CR/BR1CR < BR0CK1, 0/BR1CK1, 0 >$ .

The baud rate generator includes a 4-bit frequency divider, which divides frequency by 2 to 16 values to determine the transfer rate.

How to calculate a transfer rate when the baud rate generator is used is explained below.

## ● UART mode

$$\text{Transfer rate} = \frac{\text{Input clock of baud rate generator}}{\text{Frequency divisor of baud rate generator}} \div 16$$

## ● I/O interface mode

$$\text{Transfer rate} = \frac{\text{Input clock of baud rate generator}}{\text{Frequency divisor of baud rate generator}} \div 2$$

The relation between the input clock and the source clock ( $fc$ ) is as follows.

$$\phi T0 = fc/4$$

$$\phi T2 = fc/16$$

$$\phi T8 = fc/64$$

$$\phi T32 = fc/256$$

Accordingly, when source clock  $fc$  is 12.288 MHz, input clock is  $\phi T2$  ( $fc/16$ ), and frequency divisor is 5, the transfer rate in UART mode becomes as follows:

$$\begin{aligned} \text{Transfer rate} &= \frac{fc/16}{5} \div 16 \\ &= 12.288 \times 10^6 / 16 / 5 / 16 = 9600 \text{ (bps)} \end{aligned}$$

Table 3.11 (1) shows an example of the transfer rate in UART mode.

Also with 8-bit timer 0, the serial channel can get a transfer rate. Table 3.9 (2) shows an example of baud rate using timer 0.

Table 3.11 (1) Selection of Transfer Rate (1) (When Baud Rate Generator Is Used)  
Unit (kbps)

fc [MHz]	Input clock		$\phi$ T0 (fc/4)	$\phi$ T2 (fc/16)	$\phi$ T8 (fc/64)	$\phi$ T32 (fc/256)
	Frequency divisor					
9.830400	2		76.800	19.200	4.800	1.200
↑	4		38.400	9.600	2.400	0.600
↑	8		19.200	4.800	1.200	0.300
↑	0		9.600	2.400	0.600	0.150
12.288000	5		38.400	9.600	2.400	0.600
↑	A		19.200	4.800	1.200	0.300
14.745600	3		76.800	19.200	4.800	1.200
↑	6		38.400	9.600	2.400	0.600
↑	C		19.200	4.800	1.200	0.300

Note: Transfer rate in I/O interface mode is 8 times as fast as the values given in the above table.

Table 3.11 (2) Selection of Transfer Rate (1) (When timer 0 (input Clock  $\phi$ T1) is used)  
Unit (kbps)

TREG0	fc	12.288 MHz	12 MHz	9.8304 MHz	8 MHz	6.144 MHz
1H		96		76.8	62.5	48
2H		48		38.4	31.25	24
3H		32	31.25			16
4H		24		19.2		12
5H		19.2				9.6
8H		12		9.6		6
AH		9.6				4.8
10H		6		4.8		3
14H		4.8				2.4

How to calculate the transfer rate (when timer 0 is used):

$$\text{Transfer rate} = \frac{fc}{\text{TREG0} \times 8 \times 16}$$

(When Timer 0 (input clock  $\phi$ T1) is used)

Input clock of timer 0

$$\begin{aligned}\phi T1 &= fc/8 \\ \phi T4 &= fc/32 \\ \phi T16 &= fc/128\end{aligned}$$

Note: Timer 0 match detect signal cannot be used as the transfer clock in I/O interface mode.

## ② Serial Clock Generation Circuit

This circuit generates the basic clock for transmitting and receiving data.

### 1) I/O interface mode (channel 1 only)

When in SCLK output mode with the setting of SC0CR/SC1CR<IOC> = "0", the basic clock will be generated by dividing by 2 the output of the baud rate generator described before. When in SCLK input mode with the setting of SC0CR/SC1CR<IOC> = "1", the rising edge or falling edge will be detected according to the setting of SC0CR/SC1CR<SCLKS> register to generate the basic clock.

### 2) Asynchronous Communication (UART) mode

According to the setting of SC0CR/SC1CR <SC1, 0>, the above baud rate generator clock, internal clock  $\phi 1$  (500 kbps @  $f_c = 16$  MHz), or the match detect signal from timer 0 will be selected to generate the basic clock SIOCLK.

## ③ Receiving Counter

The receiving counter is a 4-bit binary counter used in asynchronous communication (UART) mode and counts up by SIOCLK clock. 16 pulses of SIOCLK are used for receiving 1 bit of data, and the data bit is sampled three times at 7th, 8th and 9th clock.

With the three samples, the received data is evaluated by the rule of majority.

For example, if the sampled data bit is "1", "0" and "1" at 7th, 8th and 9th clock respectively, the received data is evaluated as "1". The sampled data "0", "0" and "1" is evaluated that the received data is "0".

## ④ Receiving Control

### 1) I/O interface mode

When in SCLK output mode with the setting of SC0CR/SC1CR<IOC> = "0", RxD0/1 signal will be sampled at the rising edge of shift clock which is output to SCLK0/1 pin.

When in SCLK input mode with the setting SC0CR/SC1CR<IOC> = "1" RxD0/1 signal will be sampled at the rising edge or falling edge of SCLK input according to the setting of SC0CR/SC1CR<SCLKS> register.

### 2) Asynchronous communication (UART) mode

The receiving control has a circuit for detecting the start bit by the rule of majority. When two or more "0" are detected during 3 samples, it is recognized as start bit and the receiving operation is started.

Data being received are also evaluated by the rule of majority.

## ⑤ Receiving Buffer

To prevent overrun error, the receiving buffer has a double buffer structure.

Received data are stored one bit by one bit in the receiving buffer 1 (shift register type). When 7 bits or 8 bits of data is stored in the receiving buffer 1, the stored data are transferred to another receiving buffer 2 (SC0BUF/SC1BUF), generating an interrupt INTRX0/INTRX1. The CPU reads only receiving buffer 2 (SC0BUF/SC1BUF). Even before the CPU reads the receiving buffer 2 (SC0BUF/SC1BUF), the received data can be stored in the receiving buffer 1. However, unless the receiving buffer 2 (SC0BUF/SC1BUF) is read before all bits of the next data are received by the receiving buffer 1, an overrun error occurs. If an overrun error occurs, the contents of the receiving buffer 1 will be lost, although the contents of the receiving buffer 2 and SC0CR<RB8>/SC1CR<RB8> is still preserved.

The parity bit added in 8-bit UART mode and the most significant bit (MSB) in 9-bit UART mode are stored in SC0CR<RB8>/SC1CR<RB8>.

When in 9-bit UART mode, the wake-up function of the slave controllers is enabled by setting SC0MOD<WU>/SC1MOD<WU> to "1", and interrupt INTRX0/INTRX1 occurs only when SC0CR<RB8>/SC1CR<RB8> is set to "1".

## ⑥ Transmission Counter

Transmission counter is a 4-bit binary counter which is used in asynchronous communication (UART) mode and, like a receiving counter, counts by SIOCLK clock, generating TxDCLK every 16 clock pulses.

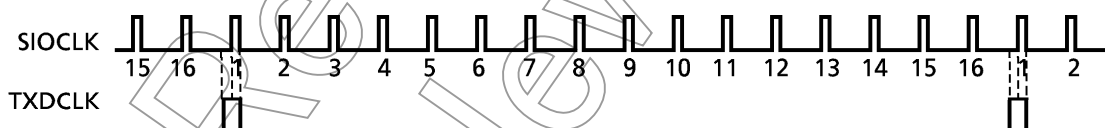

Figure 3.11 (14) Generation of Transmission Clock

## ⑦ Transmission Controller

## 1) I/O interface mode

In SCLK output mode with the setting of SC0CR/SC1CR<IOC> = "0", the data in the transmission buffer are output bit by bit to TxD0/1 pin at the rising edge of shift clock which is output from SCLK0/1 pin.

In SCLK input mode with the setting of SC0CR/SC1CR<IOC> = "1", the data in the transmission buffer are output bit by bit to TxD0/1 pin at the rising edge or falling edge of SCLK input according to the setting of SC0CR/SC1CR<SCLKS> register.

2) Asynchronous communication (UART) mode

When transmission data are written in the transmission buffer sent from the CPU, transmission starts at the rising edge of the next TxDCLK, generating a transmission shift clock TxDSFT.

Handshake function

Serial channel 0 has a  $\overline{CTS0}$  pin. Using this pin, data can be sent in units of one frame ; thus, overrun errors can be avoided. The handshake function is enabled/ disabled by SC0MOD < CTSE > .

When the  $\overline{CTS0}$  pin goes high, after completion of the current data send, data send is halted until the  $\overline{CTS0}$  pin goes low again. The INTTX0 Interrupts are generated, requests the next send data to the CPU.

Though there is no  $\overline{RTS}$  pin, a handshake function can be easily configured by setting any port assigned to the  $\overline{RTS}$  function. The  $\overline{RTS}$  should be output "High" to request data send halt after data receive is completed by a software in the RXD interrupt routine.

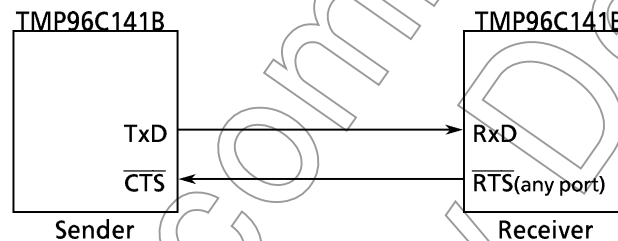
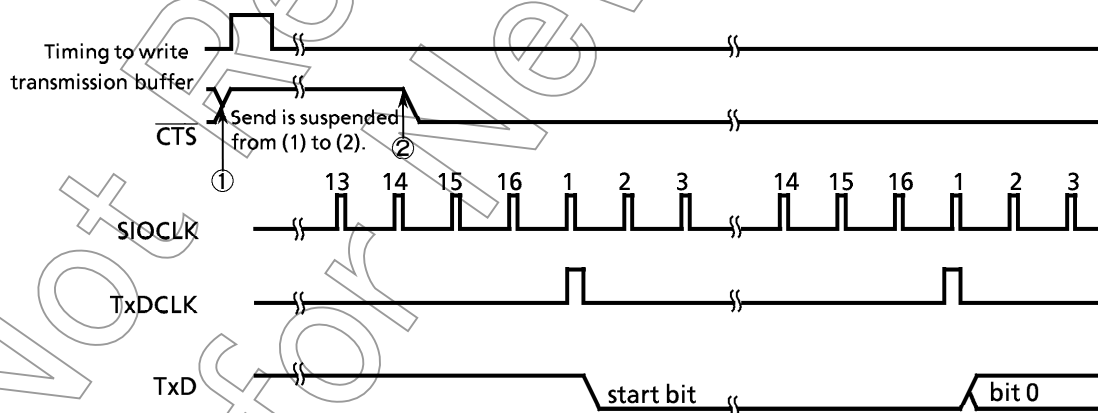

Figure 3.11 (15) Handshake Function



- Note 1 : If the  $\overline{CTS}$  signal falls during transmission, the next data is not sent after the completion of the current transmission.
- Note 2 : Transmission starts at the first TxDCLK clock fall after the  $\overline{CTS}$  signal falls.

010289

Figure 3.11 (16) Timing of  $\overline{CTS}$  (Clear to send)

### ⑧ Transmission Buffer

Transmission buffer (SC0BUF/SC1BUF) shifts out and sends the transmission data written from the CPU from the least significant bit (LSB) in order, using transmission shift clock TxDSFT which is generated by the transmission control. When all bits are shifted out, the transmission buffer becomes empty and generates INTTX0/INTTX1 interrupt.

### ⑨ Parity Control Circuit

When serial channel control register SC0CR<PE>/SC1CR<PE> is set to "1", it is possible to transmit and receive data with parity. However, parity can be added only in 7-bit UART or 8-bit UART mode. With SC0CR <EVEN> / SC1CR <EVEN> register, even (odd) parity can be selected.

For transmission, parity is automatically generated according to the data written in the transmission buffer SCBUF, and data are transmitted after being stored in SC0BUF<TB7>/SC1BUF<TB7> when in 7-bit UART mode while in SC0MOD <TB8> / SC1MOD <TB8> when in 8-bit UART mode. <PE> and <EVEN> must be set before transmission data are written in the transmission buffer.

For receiving, data are shifted in the receiving buffer 1, and parity is added after the data are transferred in the receiving buffer 2 (SC0BUF/SC1BUF), and then compared with SC0BUF<RB7>/SC1BUF<RB7> when in 7-bit UART mode and with SC0MOD<RB8>/SC1MOD<RB8> when in 8-bit UART mode. If they are not equal, a parity error occurs, and SC0CR<PERR>/SC1CR<PERR> flag is set.

### ⑩ Error Flag

Three error flags are provided to increase the reliability of receiving data.

#### 1. Overrun error <OERR>

If all bits of the next data are received in receiving buffer 1 while valid data are stored in receiving buffer 2 (SCBUF0/1), an overrun error will occur.

#### 2. Parity error <PERR>

The parity generated for the data shifted in receiving buffer 2 (SCBUF0/1) is compared with the parity bit received from RxD pin. If they are not equal, a parity error occurs.

#### 3. Framing error <FERR>

The stop bit of received data is sampled three times around the center. If the majority is "0", a framing error occurs.

① Generating Timing

1) UART mode

Receiving

Mode	9 Bit	8 Bit + parity	8 Bit, 7 Bit + parity, 7 Bit
Interrupt timing	Center of last bit (Bit 8)	Center of last bit (parity bit)	Center of stop bit
Framing error timing	Center of stop bit	Center of stop bit	Center of stop bit
Parity error timing	—	Center of last bit (parity bit)	←
Overrun error timing	Center of last bit (Bit 8)	Center of last bit (parity bit)	Center of stop bit

Transmitting

Mode	9 Bit	8 Bit + parity	8 Bit, 7 Bit + parity, 7 Bit
Interrupt timing	Just before stop bit is transmitted.	←	←

2) I/O interface mode

Transmission Interrupt timing	SCLK output mode	Immediately after rise of last SCLK signal. (See figure 3.11 (19).)
	SCLK input mode	Immediately after rise of last SCLK signal (rising mode), or immediately after fall in falling mode. (See figure 3.11 (20).)
Receiving Interrupt timing	SCLK output mode	Timing used to transfer received data to data receive buffer 2 (SC0BUF/SC1BUF) (that is, immediately after last SCLK). (See figure 3.11 (21).)
	SCLK input mode	Timing used to transfer received data to data receive buffer 2 (SC0BUF/SC1BUF) (that is, immediately after last SCLK). (See figure 3.11 (22).)

3.11.3 Operational Description

(1) Mode 0 (I/O interface mode)

This mode is used to increase the number of I/O pins of for transmitting or receiving data to or from the external shifter register.

This mode includes SCLK output mode to output synchronous clock SCLK and SCLK input mode to input external synchronous clock SCLK.

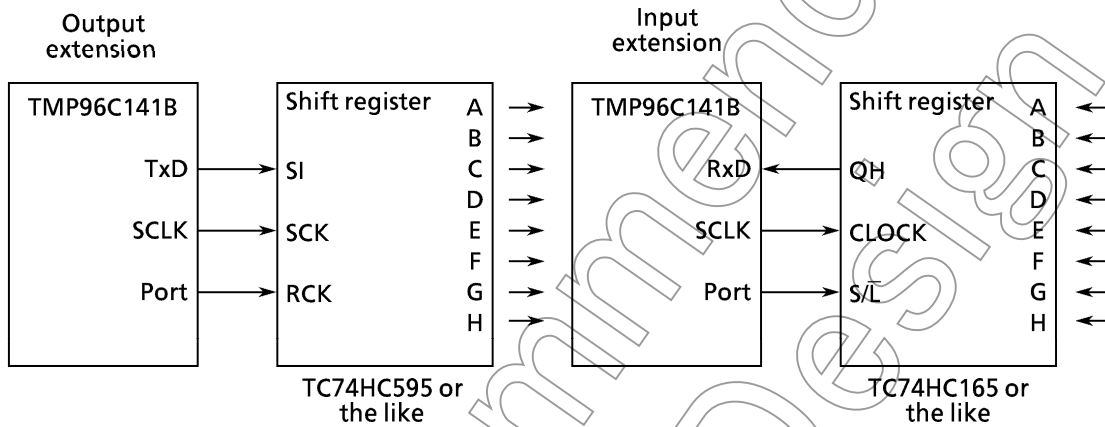

Figure 3.11 (17) Example of SCLK Output Mode Connection

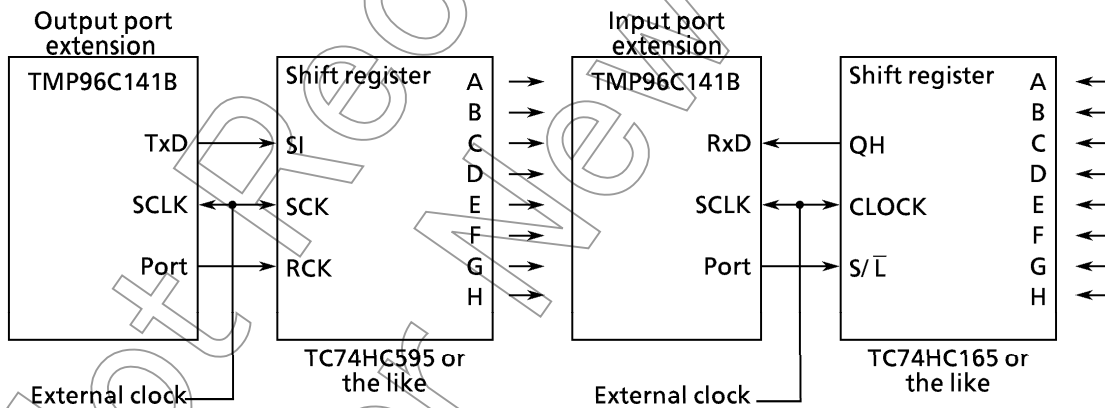

Figure 3.11 (18) Example of SCLK Input Mode Connection



## ① Transmission

In SCLK output mode, 8-bit data and synchronous clock are output from TxD pin and SCLK pin, respectively, each time the CPU writes data in the transmission buffer. When all data is output, INTES0 <ITX0C>/INTES1 <ITX1C> will be set to generate INTTX0/1 interrupt.

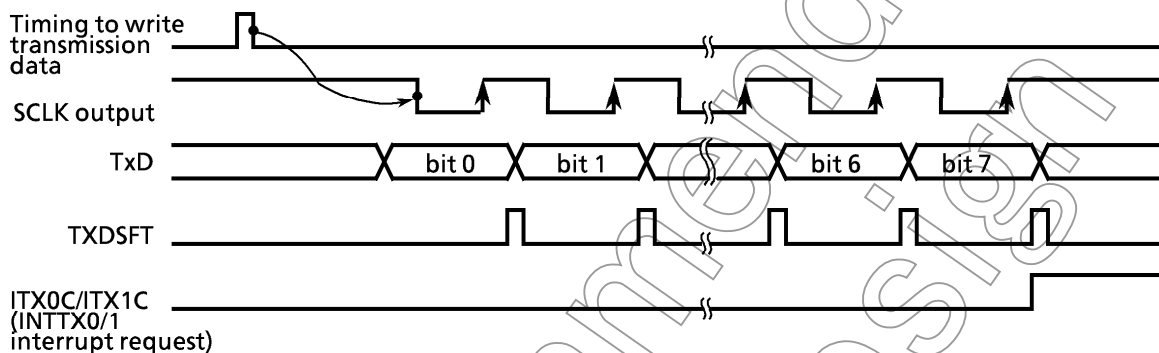

Figure 3.11 (19) Transmitting Operation in I/O Interface Mode (SCLK Output Mode)

In SCLK input mode, 8-bit data are output from TxD0/1 pin when SCLK input becomes active while data are written in the transmission buffer by CPU.

When all data are output, INTES0 <ITX0C>/INTES1 <ITX1C> will be set to generate INTTX0/1 interrupt.

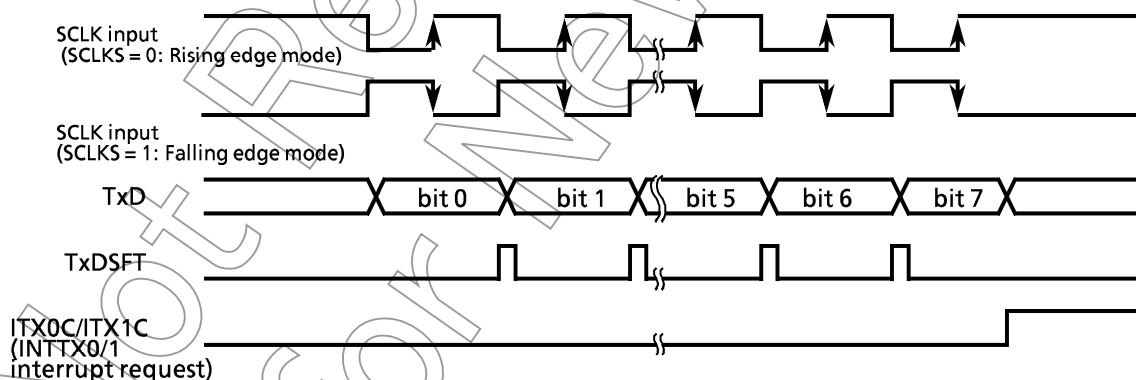

Figure 3.11 (20) Transmitting Operation in I/O Interface Mode (SCLK Input Mode)

② Receiving

In SCLK output mode, synchronous clock is outputted from SCLK pin and the data are shifted in the receiving buffer 1 whenever the receive interrupt flag INTES0<IRX0C>/INTES1<IRX1C> is cleared by reading the received data. When 8-bit data are received, the data will be transferred in the receiving buffer 2 (SC0BUF/SC1BUF) at the timing shown below, and INTES0<IRX0C>/INTES1<IRX1C> will be set again to generate INTRX0/1 interrupt.

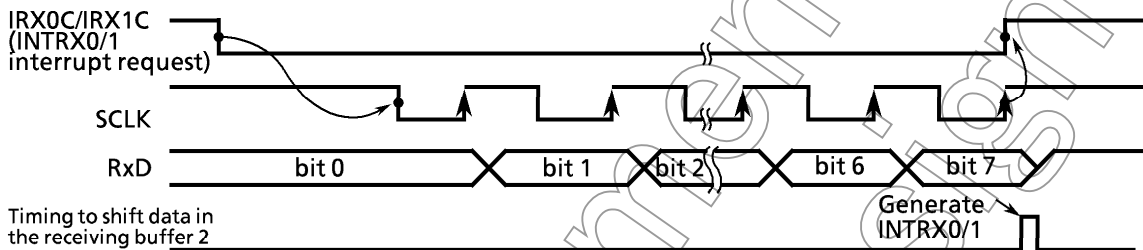

Figure 3.11 (21) Receiving Operation in I/O Interface Mode (SCLK Output Mode)

In SCLK input mode, the data is shifted in the receiving buffer 1 when SCLK input becomes active while the receive interrupt flag INTES0<IRX0C>/INTES1<IRX1C> is cleared by reading the received data. When 8-bit data is received, the data will be shifted in the receiving buffer 2 (SC0BUF/SC1BUF) at the timing shown below, and INTES0<IRX0C>/INTES1<IRX1C> will be set again to generate INTRX0/1 interrupt.

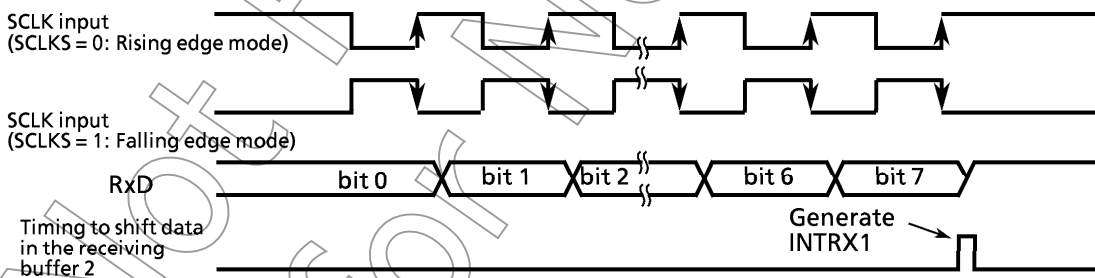

Figure 3.11 (22) Receiving Operation in I/O Interface Mode (SCLK Input Mode)

Note : For data receiving, the system must be placed in the receive enable state (SC0MOD/SC1MOD<RXE> = "1")

(2) Mode 1 (7-bit UART Mode)

7-bit mode can be set by setting serial channel mode register SC0MOD <SM1,0> / SC1MOD<SM1, 0> to “01”.

In this mode, a parity bit can be added, and the addition of a parity bit can be enabled or disabled by serial channel control register SC0CR<PE>/SC1CR<PE>, and even parity or odd parity is selected by SC0CR <EVEN>/SC1CR<EVEN> when <PE> is set to “1” (enable).

Setting example: When transmitting data with the following format, the control registers should be set as described below. Channel 0 is explained here.



	7	6	5	4	3	2	1	0		
P9CR	←	X	X	-	-	-	-	1	} Select P90 as the TxD pin.	
P9FC	←	X	X	-	X	-	X	X		
SC0MOD	←	X	0	-	X	0	1	0	1	Set 7-bit UART mode.
SC0CR	←	X	1	1	X	X	X	0	0	Add an even parity.
BR0CR	←	0	X	1	0	0	1	0	1	Set transfer rate at 2400 bps.
TRUN	←	1	X	-	-	-	-	-	-	Start the prescaler for the baud rate generator.
INTES0	←	1	1	0	0	-	-	-	-	Enable INTTX0 interrupt and set interrupt level 4.
SC0BUF	←	*	*	*	*	*	*	*	*	Set data for transmission.

Note: X; Don't care -; No change

(3) Mode 2 (8-bit UART Mode)

8-bit UART mode can be specified by setting SC0MOD<SM1, 0>/SC1MOD<SM1, 0> to “10”. In this mode, parity bit can be added, the addition of a parity bit is enabled or disabled by SC0CR<PE>/SC1CR<PE>, and even parity or odd parity is selected by SC0CR<EVEN>/SC1CR<EVEN> when <PE> is set to “1” (enable).

Setting example: When receiving data with the following format, the control register should be set as described below.

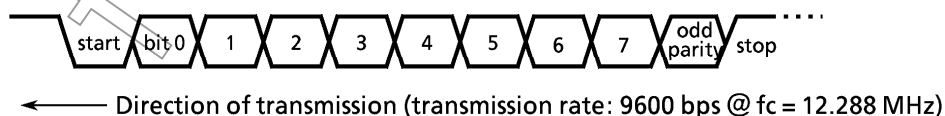

Main setting

	7 6 5 4 3 2 1 0	
P9CR	← X X - - - 0 -	Select P91 (RxD) as the input pin.
SC0MOD	← - 0 1 X 1 0 0 1	Enable receiving in 8-bit UART mode.
SC0CR	← X 0 1 X X X 0 0	Add an odd parity.
BR0CR	← 0 X 0 1 0 1 0 1	Set transfer rate at 9600 bps.
TRUN	← 1 X - - - - -	Start the prescaler for the baud rate generator.
INTES0	← - - - - 1 1 0 0	Enable INTTX0 interrupt and set interrupt level 4.

Interrupt processing

```

Acc ← SC0CR AND 00011100    } Check for error.
if Acc ≠ 0 then ERROR
Acc ← SC0BUF                } Read the received data.
    
```

Note: X; Don't care      -; No change

(4) Mode 3 (9-bit UART Mode)

9-bit UART mode can be specified by setting SC0MOD<SM1, 0>/SC1MOD<SM 1, 0> to "11". In this mode, parity bit cannot be added.

For transmission, the MSB (9th bit) is written in SCMOD <TB8>, while in receiving it is stored in SCCR<RB8>. For writing and reading the buffer, the MSB is read or written first then SC0BUF/SC1BUF.

Wake-up function

In 9-bit UART mode, the wake-up function of slave controllers is enabled by setting SC0MOD<WU>/SC1MOD<WU> to "1". The interrupt INTRX1/INTRX0 occurs only when <RB8> = 1.

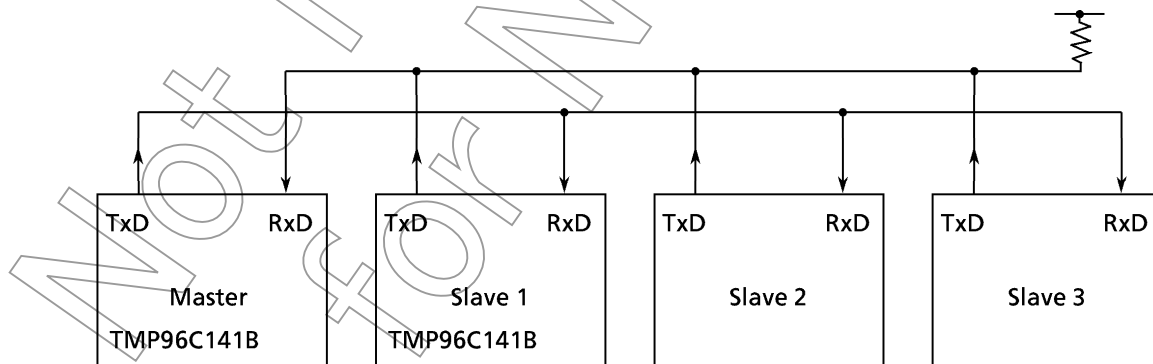

Note : TxD pin of the slave controllers must be in open drain output mode.

Figure 3.11 (23) Serial Link Using Wake-Up Function

## Protocol

- ① Select the 9-bit UART mode for the master and slave controllers.
- ② Set SC0MOD<WU>/SC1MOD<WU> bit of each slave controller to “1” to enable data receiving.
- ③ The master controller transmits one-frame data including the 8-bit select code for the slave controllers. The MSB (bit 8) <TB8> is set to “1”.

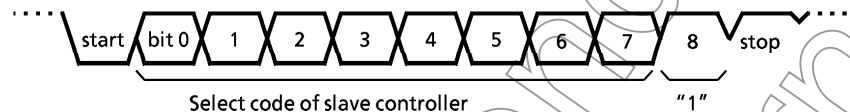

- ④ Each slave controller receives the above frame, and clears WU bit to “0” if the above select code matches its own select code.
- ⑤ The master controller transmits data to the specified slave controller whose SC0MOD<WU>/SC1MOD<WU> bit is cleared to “0”. The MSB (bit 8) <TB8> is cleared to “0”.

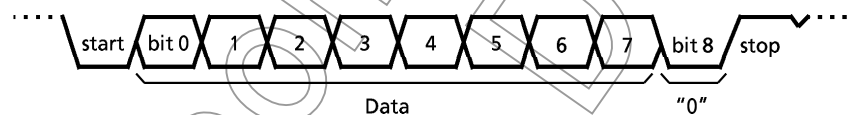

- ⑥ The other slave controllers (with the <WU> bit remaining at “1”) ignore the receiving data because their MSBs (bit 8 or <RB8>) are set to “0” to disable the interrupt INTRX0/INTRX1.

The slave controllers (<WU>=0) can transmit data to the master controller, and it is possible to indicate the end of data receiving to the master controller by this transmission.

Setting example: To link two slave controllers serially with the master controller, and use the internal clock  $\phi 1$  ( $fc/2$ ) as the transfer clock.

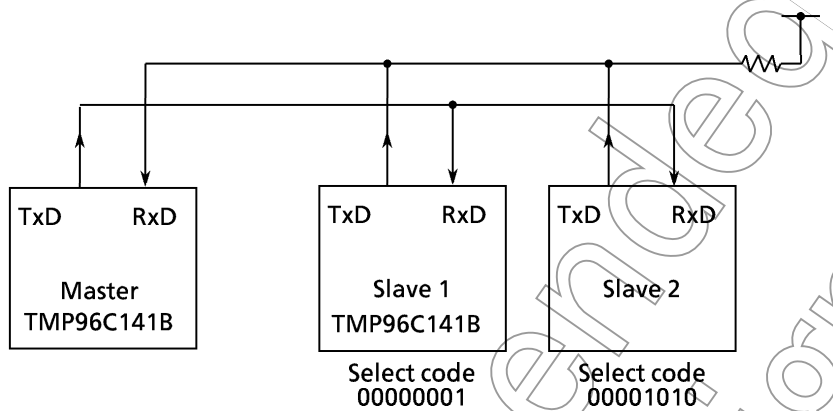

Since serial channels 0 and 1 operate in exactly the same way, channel 0 is used for the purposes of explanation.

● Setting the master controller

Main

P9CR ← X X - - - 0 1 } Select P90 as TxD pin and P91 as RxD pin.  
 P9FC ← X X - X - X X 1  
 INTES0 ← 1 1 0 0 1 1 0 1 Enable INTTX0 and set the interrupt level 4.  
 Enable INTTX0 and set the interrupt level 5.  
 SCOMOD ← 1 0 1 0 1 1 1 0 Set  $\phi 1$  ( $fc/2$ ) as the transmission clock in 9-bit UART mode.  
 SC0BUF ← 0 0 0 0 0 0 0 1 Set the select code for slave controller 1.

INTTX0 interrupt

SCOMOD ← 0 - - - - - Sets TB8 to "0".  
 SC0BUF ← \* \* \* \* \* Set data for transmission.

● Setting the slave controller 2

Main

P9CR ← X X - - - 0 1 } Select P91 as RxD pin and P90 as TxD pin (open drain  
 P9FC ← X X - X - X X 1 } output).  
 ODE ← X X X X X X - 1  
 INTES0 ← 1 1 0 1 1 1 1 0 Enable INTRX0 and INTTX0.  
 SCOMOD ← 0 0 1 1 1 1 1 0 Set <WU> to "1" in the 9-bit UART transmission mode  
 with transfer clock  $\phi 1$  ( $fc/2$ ).

INTRX0 interrupt

Acc ← SC0BUF  
 if Acc = Select code  
 Then SCOMOD4 ← - - - 0 - - - - Clear <WU> to "0".

### 3.12 Analog/Digital Converter

TMP96C141B has a high-speed analog / digital converter (A/D converter) with 4-channel analog input that features 10-bit successive approximation.

Figure 3.12 (1) shows the block diagram of the A/D converter. 4-channel analog input pins (AN3 to AN0) are shared by input-only port P5 and so can be used as input port.

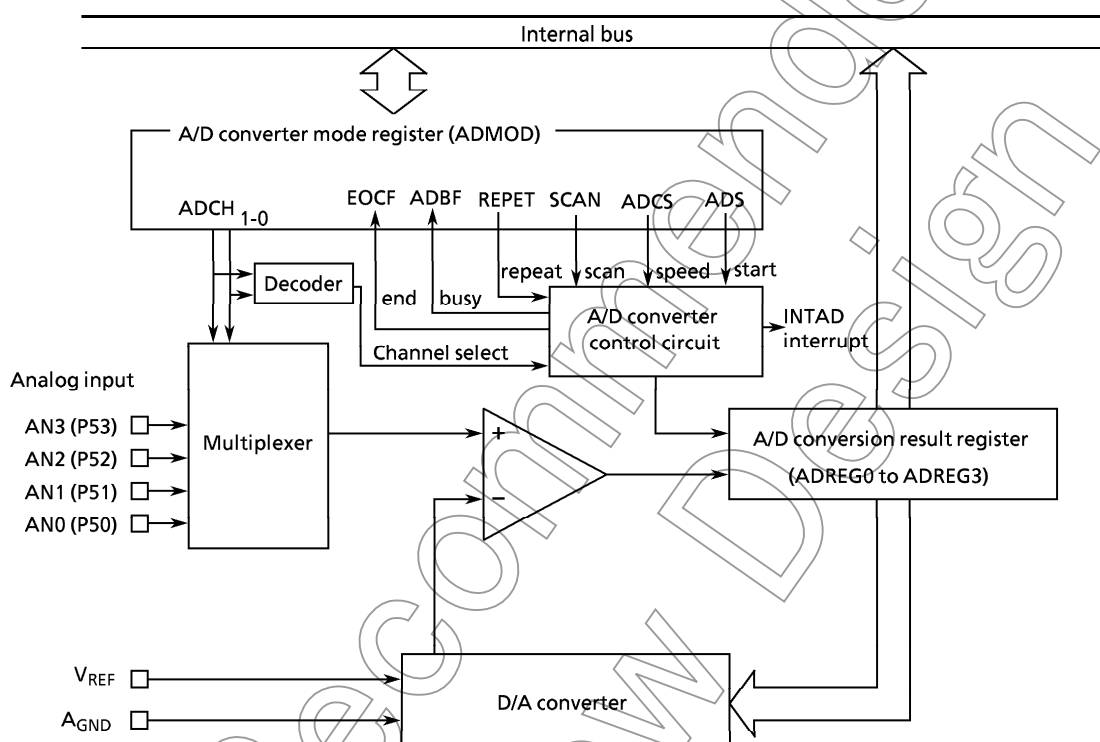

Figure 3.12 (1) Block Diagram of A/D Converter

Note 1 : This A/D converter does not have a built-in sample and hold circuit.

Therefore, when A/D converting high-frequency signals, connect a sample and hold circuit externally.

Note 2 : To lower the power supply current in IDLE or STOP mode, depending on the timing, standby mode can be entered with the internal comparator in enable state. Thus, stop A/D conversion before executing the HALT instruction.

The ladder resistor between V<sub>REF</sub> – AGND cannot be disconnected internally.

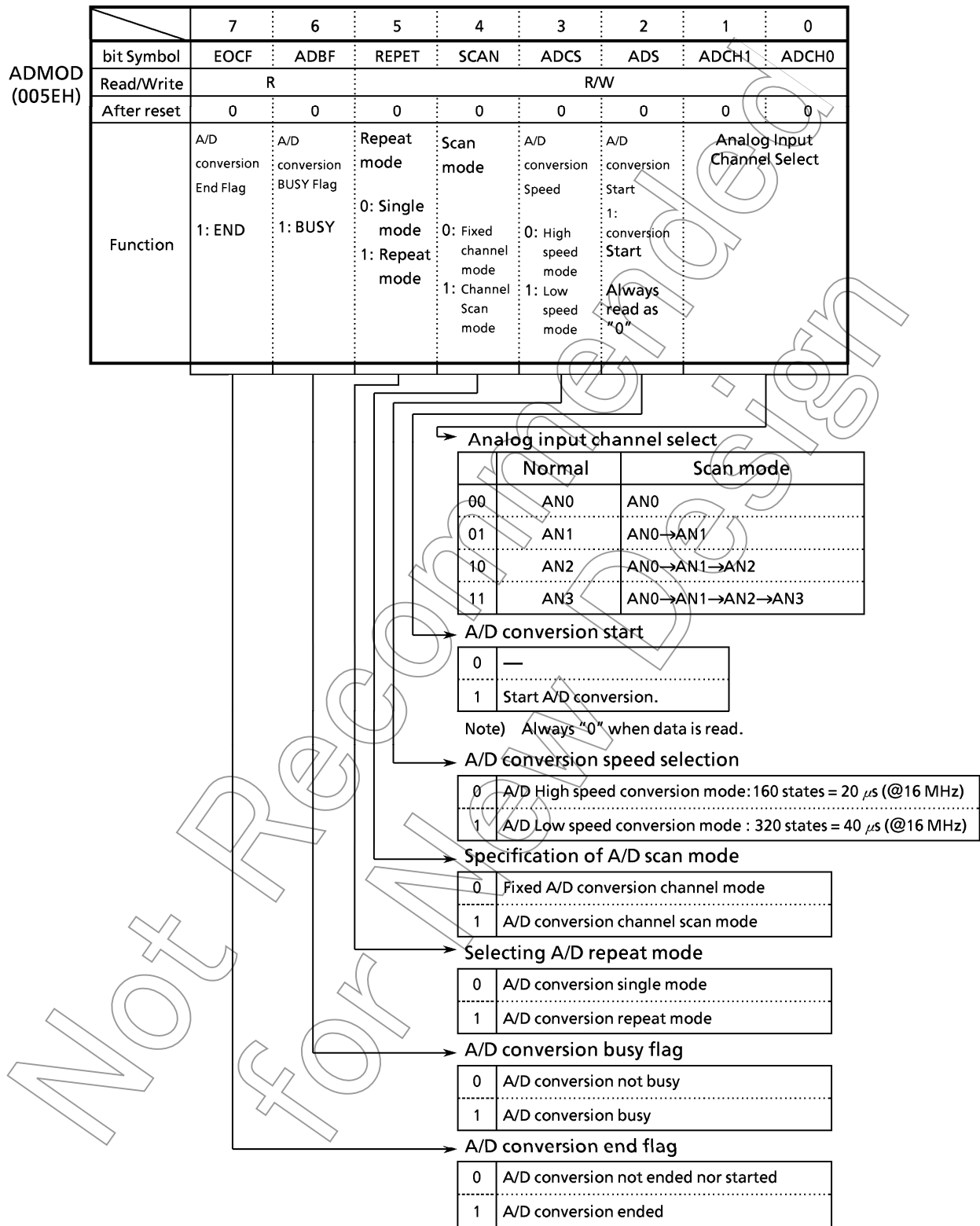

Figure 3.12 (2) A/D Control Register



	7	6	5	4	3	2	1	0
ADREG0L (0060H)	bit Symbol		ADR01	ADR00				
	Read/Write							
	R							
	After reset		Undefined	1	1	1	1	1
	Function							
	Lower 2 bits of A/D result for AN0 are stored.							

	7	6	5	4	3	2	1	0		
ADREG0H (0061H)	bit Symbol		ADR09	ADR08	ADR07	ADR06	ADR05	ADR04	ADR03	ADR02
	Read/Write									
	R									
	After reset									
	Undefined									
	Function									
	Upper 8 bits of A/D result for AN0 are stored.									

	7	6	5	4	3	2	1	0
ADREG1L (0062H)	bit Symbol		ADR11	ADR10				
	Read/Write							
	R							
	After reset		Undefined	1	1	1	1	1
	Function							
	Lower 2 bits of A/D result for AN1 are stored.							

	7	6	5	4	3	2	1	0		
ADREG1H (0063H)	bit Symbol		ADR19	ADR18	ADR17	ADR16	ADR15	ADR14	ADR13	ADR12
	Read/Write									
	R									
	After reset									
	Undefined									
	Function									
	Upper 8 bits of A/D result for AN1 are stored.									

Figure 3.12 (3-1) A/D Conversion Result Register (ADREG0, 1)

	7	6	5	4	3	2	1	0
ADREG2L (0064H)	bit Symbol	ADR21	ADR20	/				
	Read/Write	R						
	After reset	Undefined	1	1	1	1	1	1
	Function	Lower 2 bits of A/D result for AN2 are stored.						

	7	6	5	4	3	2	1	0	
ADREG2H (0065H)	bit Symbol	ADR29	ADR28	ADR27	ADR26	ADR25	ADR24	ADR23	ADR22
	Read/Write	R							
	After reset	Undefined							
	Function	Upper 8 bits of A/D result for AN2 are stored.							

	7	6	5	4	3	2	1	0
ADREG3L (0066H)	bit Symbol	ADR31	ADR30	/				
	Read/Write	R						
	After reset	Undefined	1	1	1	1	1	1
	Function	Lower 2 bits of A/D result for AN3 are stored.						

	7	6	5	4	3	2	1	0	
ADREG3H (0067H)	bit Symbol	ADR39	ADR38	ADR37	ADR36	ADR35	ADR34	ADR33	ADR32
	Read/Write	R							
	After reset	Undefined							
	Function	Upper 8 bits of A/D result for AN3 are stored.							

Figure 3.12 (3-2) A/D Conversion Result Register (ADREG2, 3)

### 3.12.1 Operation

#### (1) Analog Reference Voltage

High analog reference voltage is applied to the VREF pin, and the low analog reference voltage is applied to AGND pin.

The reference voltage between VREF and AGND is divided by 1024 using ladder resistance, and compared with the analog input voltage for A/D conversion.

#### (2) Analog Input Channels

Analog input channel to select depends on the operation mode of the A/D converter.

In fixed analog input mode, one channel is selected by  $ADMOD \langle ADCH1,0 \rangle$  among four pins: AN0 to AN3.

In analog input channel scan mode, the number of channels to be scanned from AN0 is specified by  $ADMOD \langle ADCH1,0 \rangle$ , such as AN0→AN1, AN0→AN1→AN2, and AN0→AN1→AN2→AN3.

When reset, A/D conversion channel register will be initialized to  $ADMOD \langle ADCH1,0 \rangle = 00$ , so that AN0 pin will be selected.

The pins which are not used as analog input channel can be used as ordinary input port P5.

#### (3) Starting A/D Conversion

A/D conversion starts when A/D conversion register  $ADMOD \langle ADS \rangle$  is written "1". When A/D conversion starts, A/D conversion busy flag  $ADMOD \langle ADBF \rangle$  which indicates "A/D conversion is in progress" will be set to "1".

#### (4) A/D Conversion Mode

Both fixed A/D conversion channel mode and A/D conversion channel scan mode have two conversion modes, i.e., single and repeat conversion modes.

In fixed channel repeat mode, conversion of specified one channel is executed repeatedly.

In scan repeat mode, scanning from AN0, ... →AN3 is executed repeatedly.

A/D conversion mode is selected by  $ADMOD \langle REPET, SCAN \rangle$ .

#### (5) A/D Conversion Speed Selection

There are two A/D conversion speed modes: high speed mode and low speed mode. The selection is executed by  $ADMOD \langle ADCS \rangle$  register.

When reset,  $ADMOD \langle ADCS \rangle$  will be initialized to "0", so that high speed conversion mode will be selected.

#### (6) A/D Conversion End and Interrupt

- A/D conversion single mode

ADMOD<EOCF> for A/D conversion end will be set to “1”, ADMOD<ADBF> flag will be reset to “0”, and INTAD interrupt will be enabled when A/D conversion of specified channel ends in fixed conversion channel mode or when A/D conversion of the last channel ends in channel scan mode.

- A/D conversion repeat mode

For both fixed conversion channel mode and conversion channel scan mode, INTAD should be disabled when in repeat mode. Always set the INTE0AD at “000”, that disables the interrupt request.

Write “0” to ADMOD<REPET> to end the repeat mode. Then, the repeat mode will be exited as soon as the conversion in progress is completed.

When A/D conversion changes to the halt state of IDLE and STOP mode, even if in A/D converting state, A/D converter immediately stops the operation. After releasing the halt, the conversion does not restart.

### (7) Storing the A/D Conversion Result

The results of A/D conversion are stored in ADREG0 to ADREG3 registers for each channel. In repeat mode, the registers are updated whenever conversion ends.

ADREG0 to ADREG3 are read-only registers.

### (8) Reading the A/D Conversion Result

The results of A/D conversion are stored in ADREG0 to ADREG3 registers. When the contents of one of ADREG0 to ADREG3 registers are read, ADMOD<EOCF> will be cleared to “0”.

Setting example: ① When the analog input voltage of the AN3 pin is A/D converted and the result is stored in the memory address FF10H by A/D interrupt INTAD routine

Main setting		
INTE0AD	← 1 1 0 0 - - - -	Enable INTAD and set interrupt level 4.
ADMOD	← X X 0 0 0 1 1 1	Specify AN3 pin as an analog input channel and starts A/D conversion in high speed mode.
INTAD routine		
WA	← ADREG3	Read ADREG3L and ADREG3H values and write to WA (16 bit)
WA	>> 6	Right-shifts WA six times and writes 0 in upper bits.
(00FF10H)	← WA	Writes contents of WA in memory at FF10H

When the analog input voltage of AN0 to AN2 pins is A/D converted in high speed conversion channel scan repeat mode

INTE0AD	← 1 0 0 0 - - - -	Disable INTAD.
ADMOD	← X X 1 1 0 1 1 0	Start the A/D conversion of analog input channels AN0 to AN2 in the high-speed scan repeat mode.

Note: X ; Don't care      - ; No change



The watchdog timer is a 22-stage binary counter which uses  $\phi(fc/2)$  as the input clock. There are four outputs from the binary counter:  $2^{16}/fc$ ,  $2^{18}/fc$ ,  $2^{20}/fc$ , and  $2^{22}/fc$ . Selecting one of the outputs with the WDMOD register generates a watchdog interrupt, and outputs watchdog timer out when an overflow occurs.

Since the watchdog timer out pin ( $\overline{\text{WDTOUT}}$ ) outputs "0" due to a watchdog timer overflow, the peripheral devices can be reset. The watchdog timer out pin is set to 1 by clearing the watchdog timer (by writing a clear code 4EH in the WDCR register). In other words, the  $\overline{\text{WDTOUT}}$  keeps outputting "0" until the clear code is written.

The watchdog timer out pin can also be connected to the reset pin internally. In this case, the watchdog timer out pin ( $\overline{\text{WDTOUT}}$ ) outputs 0 at 8 to 20 states (800 ns to 2  $\mu\text{s}$  @ 20 MHz) and resets itself.

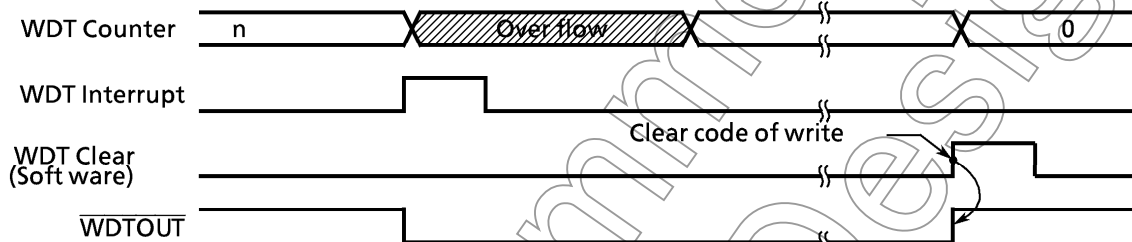

Figure 3.13 (2) Normal Mode

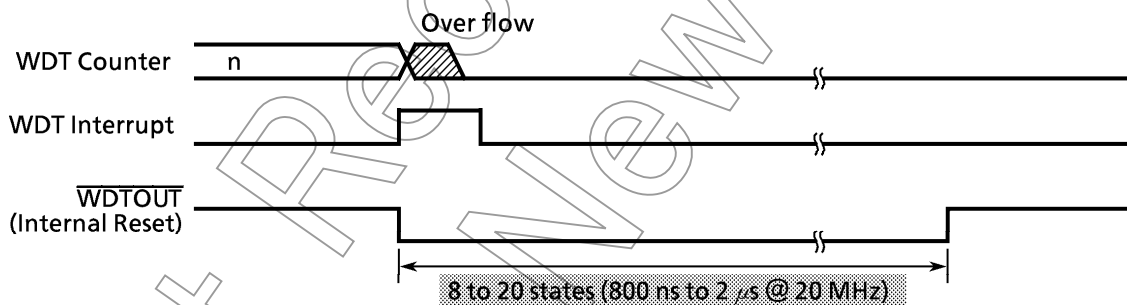

Figure 3.13 (3) Reset Mode

## 3.13.2 Control Registers

Watchdog timer WDT is controlled by two control registers WDMOD and WDCR.

## (1) Watchdog Timer Mode Register (WDMOD)

## ① Setting the detecting time of watchdog timer &lt;WDTP&gt;

This 2-bit register is used to set the watchdog timer interrupt time for detecting the runaway. This register is initialized to WDMOD<WDTP1, 0>=00 when reset, and therefore  $2^{16}/f_c$  is set. (The number of states is approx. 32,768.)

## ② Watchdog timer enable/disable control register &lt;WDTE&gt;

When reset, WDMOD<WDTE> is initialized to "1" enable the watchdog timer. To disable, it is necessary to clear this bit to "0" and write the disable code (B1H) in the watchdog timer control register WDCR. This makes it difficult for the watchdog timer to be disabled by runaway.

However, it is possible to return from the disable state to enable state by merely setting <WDTE> to "1".

## ③ Watchdog timer out reset connection &lt;RESCR&gt;

This register is used to connect the output of the watchdog timer with RESET terminal, internally. Since WDMOD<RESCR> is initialized to 0 at reset, a reset by the watchdog timer will not be performed.

## (2) Watchdog Timer Control Register (WDCR)

This register is used to disable and clear of binary counter the watchdog timer function.

## ● Disable control

By writing the disable code (B1H) in this WDCR register after clearing WDMOD<WDTE> to "0", the watchdog timer can be disabled.

WDMOD	← 0 - - - - X X	Clear WDMOD<WDTE> to "0".
WDCR	← 1 0 1 1 0 0 0 1	Write the disable code (B1H).

## ● Enable control

Set WDMOD<WDTE> to "1".

## ● Watchdog timer clear control

The binary counter can be cleared and resume counting by writing clear code (4EH) into the WDCR register.

WDCR	← 0 1 0 0 1 1 1 0	Write the clear code (4EH).
------	-------------------	-----------------------------

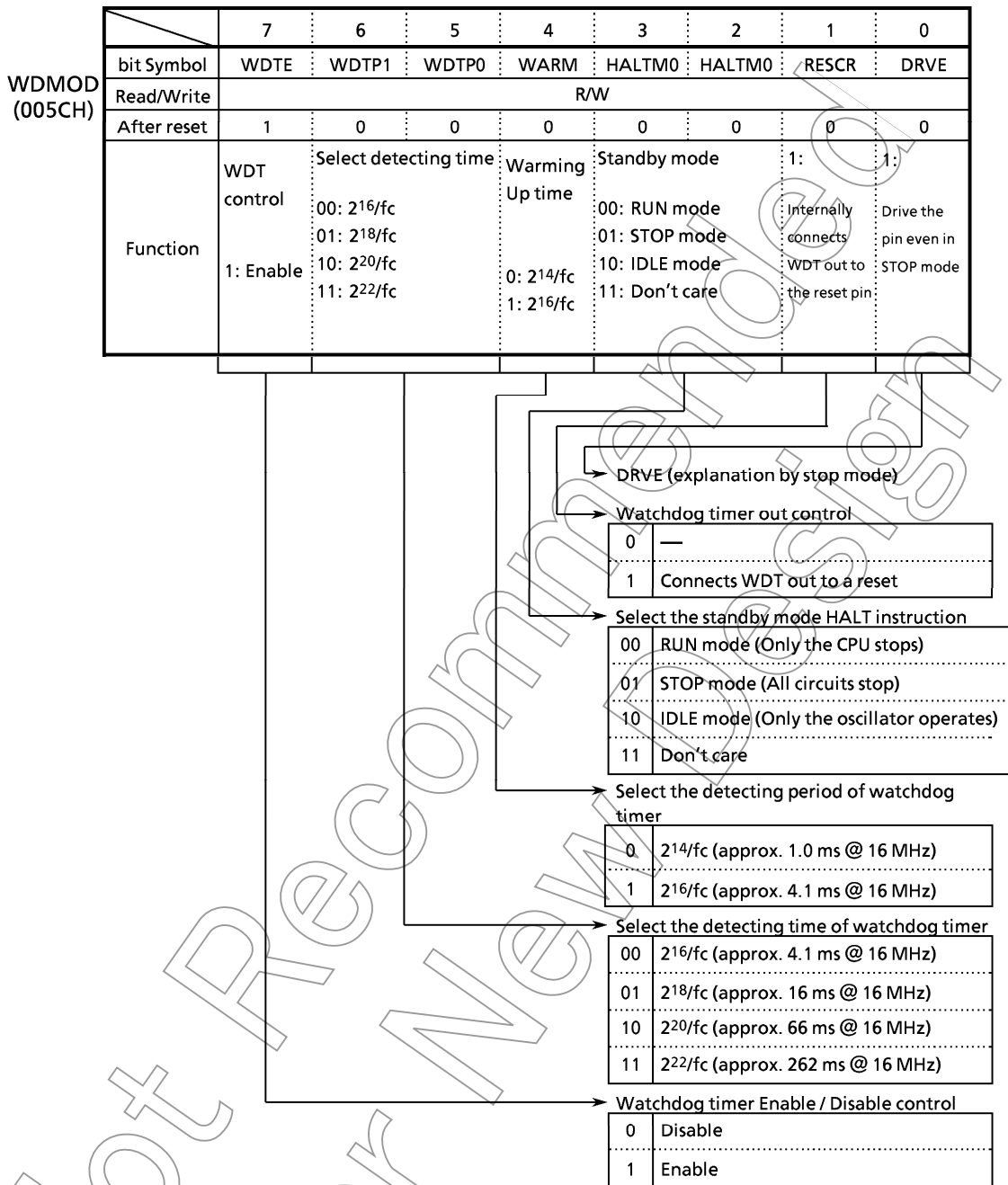

Figure 3.13 (4) Watchdog Timer Mode Register



		7	6	5	4	3	2	1	0	
WDCR (005DH)	bit Symbol					-				
	Read/Write					W				
	After reset					-				
	Function	B1H : WDT disable code 4EH : WDT clear code								

		Disable/clear WDT	
B1H	Disable code		
4EH	Clear code		
Others	—		

Figure 3.13 (5) Watchdog Timer Control Register

Not Recommended for New Design

## 3.13.3 Operation

The watchdog timer generates interrupt INTWD after the detecting time set in the WDMOD<WDTP1, 0>register and outputs a low level signal. The watchdog timer must be zero-cleared by software before an INTWD interrupt is generated. If the CPU malfunctions (runaway) due to causes such as noise, but does not execute the instruction used to clear the binary counter, the binary counter overflows and an INTWD interrupt is generated. The CPU detects malfunction (runaway) due to the INTWD Interrupt and it is possible to return to normal operation by an anti-mulfunction program. By connecting the watchdog timer out pin to peripheral devices' resets, a CPU malfunction can also be acknowledged to other devices.

The watchdog timer restarts operation immediately after resetting is released.

The watchdog timer stops its operation in the IDLE and STOP modes. In the bus releasing, the watchdog timer continues the counting. In the RUN mode, the watchdog timer is enabled.

However, the function can be disabled when entering the RUN mode.

Example : ① Clear the binary counter

WDCR ← 0 1 0 0 1 1 1 0      Write clear code (4EH).

② Set the watchdog timer detecting time to  $2^{18}/f_c$

WDMOD ← 1 0 1 - - - X X

③ Disable the watchdog timer.

WDMOD ← 0 - - - - X X      Clear WDTE to "0".  
WDCR ← 1 0 1 1 0 0 0 1      Write disable code (B1H).

④ Set IDLE mode.

WDMOD ← 0 - - - 1 0 X X      Disables WDT and sets IDLE mode.  
WDCR ← 1 0 1 1 0 0 0 1      Set the standby mode  
Executes HALT command

⑤ Set the STOP mode (warming up time:  $2^{16}/f_c$ )

WDMOD ← - - - 1 0 1 X X      Set the STOP mode.  
Executes HALT command.      Execute HALT instruction. Set the standby mode.

## 4. Electrical Characteristics

### 4.1 Absolute Maximum Ratings (TMP96C141BF)

Parameter	Symbol	Rating	Unit
Power Supply voltage	V <sub>CC</sub>	-0.5 to 6.5	V
Input voltage	V <sub>IN</sub>	-0.5 to V <sub>CC</sub> + 0.5	V
Output Current (total)	∑ I <sub>OL</sub>	100	mA
Output Current (total)	∑ I <sub>OH</sub>	-100	mA
Power Dissipation (T <sub>a</sub> = 70°C)	P <sub>D</sub>	500	mW
Soldering Temperature (10 s)	T <sub>SOLDER</sub>	260	°C
Storage temperature	T <sub>STG</sub>	-65 to 150	°C
Operating temperature	T <sub>OPR</sub>	-40 to 85	°C

Note : The absolute maximum ratings are rated values which must not be exceeded during operation, even for an instant. Any one of the ratings must not be exceeded. If any absolute maximum rating is exceeded, a device may break down or its performance may be degraded, causing it to catch fire or explode resulting in injury to the user. Thus, when designing products which include this device, ensure that no absolute maximum rating value will ever be exceeded.

Not Recommended for New Design

## 4.2 DC Characteristics (TMP96C141BF)

 $V_{CC} = 5\text{ V} \pm 10\%$ ,  $T_A = -40\text{ to }85^\circ\text{C}$  (4 to 16 MHz)  $T_A = -20\text{ to }70^\circ\text{C}$  (4 to 20 MHz)
(Typical values are for  $T_a = 25^\circ\text{C}$  and  $V_{CC} = 5\text{ V}$ )

Parameter	Symbol	Test Condition	Min	Max	Unit
Input Low Voltage (AD0 – 15)	V <sub>IL</sub>		-0.3	0.8	V
P2, P3, P4, P5, P6, P7, P8, P9	V <sub>IL1</sub>		-0.3	0.3 V <sub>CC</sub>	V
RESET, NMI, INT0 (P87)	V <sub>IL2</sub>		-0.3	0.25 V <sub>CC</sub>	V
EA	V <sub>IL3</sub>		-0.3	0.3	V
X1	V <sub>IL4</sub>		-0.3	0.2 V <sub>CC</sub>	V
Input High Voltage (AD0 – 15)	V <sub>IH</sub>		2.2	V <sub>CC</sub> + 0.3	V
P2, P3, P4, P5, P6, P7, P8, P9	V <sub>IH1</sub>		0.7 V <sub>CC</sub>	V <sub>CC</sub> + 0.3	V
RESET, NMI, INT0 (P87)	V <sub>IH2</sub>		0.75 V <sub>CC</sub>	V <sub>CC</sub> + 0.3	V
EA	V <sub>IH3</sub>		V <sub>CC</sub> - 0.3	V <sub>CC</sub> + 0.3	V
X1	V <sub>IH4</sub>		0.8 V <sub>CC</sub>	V <sub>CC</sub> + 0.3	V
Output Low Voltage	V <sub>OL</sub>	I <sub>OL</sub> = 1.6 mA		0.45	V
Output High Voltage	V <sub>OH</sub>	I <sub>OH</sub> = -400 $\mu$ A	2.4		V
	V <sub>OH1</sub>	I <sub>OH</sub> = -100 $\mu$ A	0.75 V <sub>CC</sub>		V
	V <sub>OH2</sub>	I <sub>OH</sub> = -20 $\mu$ A	0.9 V <sub>CC</sub>		V
Darlington Drive Current (8 Output Pins max.)	I <sub>DAR</sub>	V <sub>EXT</sub> = 1.5 V R <sub>EXT</sub> = 1.1 k $\Omega$	-1.0	-3.5	mA
Input Leakage Current	I <sub>LI</sub>	0.0 $\leq$ V <sub>in</sub> $\leq$ V <sub>CC</sub>	0.02 (Typ)	$\pm$ 5	$\mu$ A
Output Leakage Current	I <sub>LO</sub>	0.2 $\leq$ V <sub>in</sub> $\leq$ V <sub>CC</sub> - 0.2	0.05 (Typ)	$\pm$ 10	$\mu$ A
Operating Current (RUN)	I <sub>CC</sub>	f <sub>osc</sub> = 20MHz	21 (Typ)	50	mA
IDLE			1.7 (Typ)	10	mA
STOP (T <sub>a</sub> = -40 to 85 $^\circ$ C)		0.2 $\leq$ V <sub>in</sub> $\leq$ V <sub>CC</sub> - 0.2	0.2 (Typ)	50	$\mu$ A
STOP (T <sub>a</sub> = 0 to 50 $^\circ$ C)		0.2 $\leq$ V <sub>in</sub> $\leq$ V <sub>CC</sub> - 0.2		10	$\mu$ A
Power Down Voltage (@ STOP, RAM Back up)	V <sub>STOP</sub>	V <sub>IL2</sub> = 0.2V <sub>CC</sub> , V <sub>IH2</sub> = 0.8V <sub>CC</sub>	2.0	6.0	V
RESET Pull Up Resistor	R <sub>RST</sub>		50	150	k $\Omega$
Pin Capacitance	C <sub>IO</sub>	t <sub>osc</sub> = 1 MHz		10	pF
Schmitt Width RESET, NMI, INT0 (P87)	V <sub>TH</sub>		0.4	1.0 (Typ)	V
Programmable Pull Down Resistor	R <sub>KL</sub>		10	80	k $\Omega$
Programmable Pull Up Resistor	R <sub>KH</sub>		50	150	k $\Omega$

Note: I-DAR is guaranteed for a total of up to 8 ports.

## 4.3 AC Electrical Characteristics (TMP96C141BF)

V<sub>cc</sub> = 5 V ± 10%, T<sub>A</sub> = -40 to 85°C (4 to 16 MHz) T<sub>A</sub> = -20 to 70°C (4 to 20 MHz)

No.	Parameter	Symbol	Variable		16 MHz		20 MHz		Unit
			Min	Max	Min	Max	Min	Max	
1	Osc. Period (= x)	t <sub>OSC</sub>	50	250	62.5		50		ns
2	CLK width	t <sub>CLK</sub>	2x - 40		85		60		ns
3	A0 to 23 Valid → CLK Hold	t <sub>AK</sub>	0.5x - 20		11		5		ns
4	CLK Valid → A0 to 23 Hold	t <sub>KA</sub>	1.5x - 70		24		5		ns
5	A0 to 15 Valid → ALE fall	t <sub>AL</sub>	0.5x - 15		16		10		ns
6	ALE fall → A0 to 15 Hold	t <sub>LA</sub>	0.5x - 15		16		10		ns
7	ALE High width	t <sub>LL</sub>	x - 40		23		10		ns
8	ALE fall → RD/WR fall	t <sub>LC</sub>	0.5x - 30		1		-5		ns
9	R <sub>D</sub> /W <sub>R</sub> rise → ALE rise	t <sub>CL</sub>	0.5x - 20		11		5		ns
10	A0 to 15 Valid → R <sub>D</sub> /W <sub>R</sub> fall	t <sub>ACL</sub>	x - 25		38		25		ns
11	A0 to 23 Valid → R <sub>D</sub> /W <sub>R</sub> fall	t <sub>ACH</sub>	1.5x - 50		44		25		ns
12	R <sub>D</sub> /W <sub>R</sub> rise → A0 to 23 Hold	t <sub>CA</sub>	0.5x - 20		11		5		ns
13	A0 to 15 Valid → D0 to 15 input	t <sub>ADL</sub>		3.0x - 45		143		105	ns
14	A0 to 23 Valid → D0 to 15 input	t <sub>ADH</sub>		3.5x - 65		154		110	ns
15	R <sub>D</sub> fall → D0 to 15 input	t <sub>RD</sub>		2.0x - 50		75		50	ns
16	R <sub>D</sub> Low width	t <sub>RR</sub>	2.0x - 40		85		60		ns
17	R <sub>D</sub> rise → D0 to 15 Hold	t <sub>HR</sub>	0		0		0		ns
18	R <sub>D</sub> rise → A0 to 15output	t <sub>RAE</sub>	x - 15		48		35		ns
19	W <sub>R</sub> Low width	t <sub>WW</sub>	2.0x - 40		85		60		ns
20	D0 to 15 Valid → W <sub>R</sub> rise	t <sub>DW</sub>	2.0x - 50		75		50		ns
21	W <sub>R</sub> rise → D0 to 15 Hold	t <sub>WD</sub>	0.5x - 10		21		15		ns
22	A0 to 23 Valid → W <sub>A</sub> I <sub>T</sub> input <sup>(1WAIT +n mode)</sup>	t <sub>AEH</sub>		3.5x - 90		129		85	ns
23	A0 to 15 Valid → W <sub>A</sub> I <sub>T</sub> input <sup>(1WAIT +n mode)</sup>	t <sub>AWL</sub>		3.0x - 80		108		70	ns
24	R <sub>D</sub> /W <sub>R</sub> fall → W <sub>A</sub> I <sub>T</sub> Hold <sup>(1WAIT +n mode)</sup>	t <sub>CW</sub>	2.0x + 0		125		100		ns
25	A0 to 23 Valid → PORT input	t <sub>APH</sub>		2.5x - 120		36		5	ns
26	A0 to 23 Valid → PORT Hold	t <sub>APH2</sub>	2.5x + 50		206		175		ns
27	W <sub>R</sub> rise → PORT Valid	t <sub>CP</sub>		200		200		200	ns
28	A0 to 23 Valid → R <sub>A</sub> S fall	t <sub>ASRH</sub>	1.0x - 40		23		10		ns
29	A0 to 15 Valid → R <sub>A</sub> S fall	t <sub>ASRL</sub>	0.5x - 15		16		10		ns
30	R <sub>A</sub> S fall → D0 to 15 input	t <sub>RAC</sub>		2.5x - 70		86		55	ns
31	R <sub>A</sub> S fall → A0 to 15 Hold	t <sub>RAH</sub>	0.5x - 15		16		10		ns
32	R <sub>A</sub> S Low width	t <sub>RAS</sub>	2.0x - 40		85		60		ns
33	R <sub>A</sub> S High width	t <sub>RP</sub>	2.0x - 40		85		60		ns
34	C <sub>A</sub> S fall → R <sub>A</sub> S rise	t <sub>RSH</sub>	1.0x - 35		28		15		ns
35	R <sub>A</sub> S rise → C <sub>A</sub> S rise	t <sub>RSC</sub>	0.5x - 25		6		0		ns
36	R <sub>A</sub> S fall → C <sub>A</sub> S fall	t <sub>RCD</sub>	1.0x - 40		23		10		ns
37	C <sub>A</sub> S fall → D0 to 15 input	t <sub>CAC</sub>		1.5x - 65		29		10	ns
38	C <sub>A</sub> S Low width	t <sub>CAS</sub>	1.5x - 30		64		40		ns
39	D0 to 15 Valid → C <sub>A</sub> S fall	t <sub>DS</sub>	0.5x - 15		16		10		ns

## AC Measuring Conditions

- Output Level : High 2.2 V /Low 0.8 V , CL = 50 pF  
(However CL = 100pF for AD0 to AD15, A0 to A23, ALE, R<sub>D</sub>, W<sub>R</sub>, H<sub>W</sub>R, R/W, CLK, R<sub>A</sub>S, C<sub>A</sub>S0 to C<sub>A</sub>S2)
- Input Level : High 2.4 V /Low 0.45 V (AD0 to AD15)  
High 0.8 V<sub>cc</sub> /Low 0.2 V<sub>cc</sub> (Except for AD0 to AD15)



(2) Write Cycle

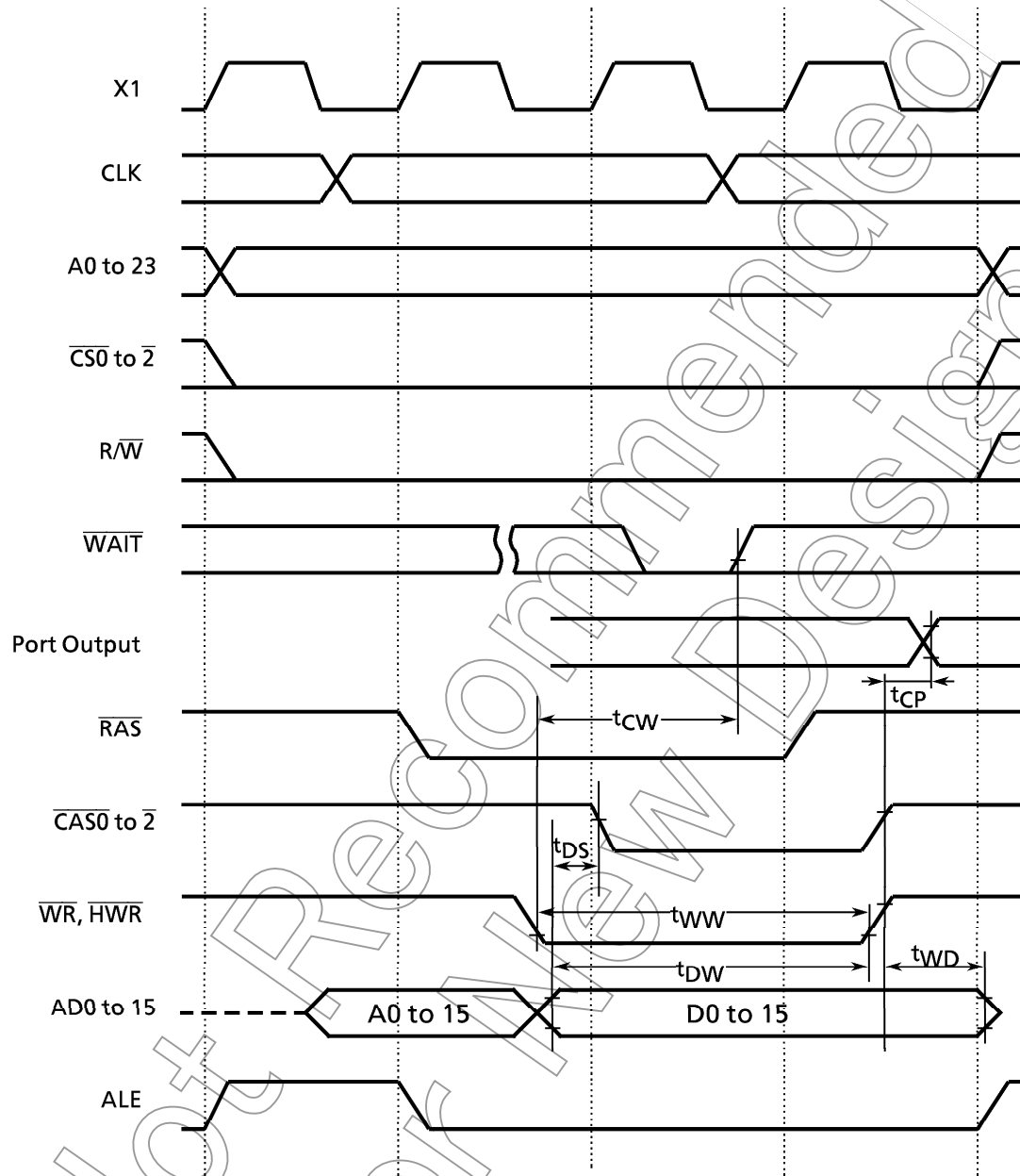

## 4.4 A/D Conversion Characteristics (TMP96C141BF)

 $V_{CC} = 5V \pm 10\%$ ,  $T_A = -40$  to  $85^\circ\text{C}$  (4 to 16 MHz)  $T_A = -20$  to  $70^\circ\text{C}$  (4 to 20 MHz)

Parameter		Symbol	Min	Typ.	Max	Unit
Analog reference voltage		$V_{REF}$	$V_{CC} - 1.5$		$V_{CC}$	V
Analog reference voltage		$A_{GND}$	$V_{SS}$		$V_{SS}$	
Analog input voltage range		$V_{AIN}$	$V_{SS}$		$V_{CC}$	
Analog current for analog reference voltage		$I_{REF}$		0.5	1.5	mA
$4 \leq f_c$ $\leq 16$ MHz	Low speed conversion mode	Error(Quantize error of $\pm 0.5$ LSB not included)		$\pm 1.5$	$\pm 4.0$	LSB
	High speed conversion mode			$\pm 3.0$	$\pm 6.0$	
$16 \leq f_c$ $\leq 20$ MHz	Low speed conversion mode		$\pm 1.5$	$\pm 4.0$		
	High speed conversion mode		$\pm 4.0$	$\pm 8.0$		

## 4.5 Serial Channel Timing – I/O Interface Mode

## (1) SCLK Input Mode

 $V_{CC} = 5V \pm 10\%$ ,  $T_A = -40$  to  $85^\circ\text{C}$  (4 to 16 MHz)  $T_A = -20$  to  $70^\circ\text{C}$  (4 to 20 MHz)

Parameter	Symbol	Variable		16 MHz		20 MHz		Unit
		Min	Max	Min	Max	Min	Max	
SCLK cycle	$t_{SCY}$	16X		1		0.8		$\mu\text{s}$
Output Data → Rising edge of SCLK	$t_{OSS}$	$t_{SCY}/2 - 5X - 50$		137		100		ns
SCLK rising edge → Output Data hold	$t_{OHS}$	$5X - 100$		212		150		ns
SCLK rising edge → Input Data hold	$t_{HSR}$	0		0		0		ns
SCLK rising edge → effective data input	$t_{SRD}$			$t_{SCY} - 5X - 100$	587		450	ns

## (2) SCLK Output Mode

 $V_{CC} = 5V \pm 10\%$ ,  $T_A = -40$  to  $85^\circ\text{C}$  (4 to 16 MHz)  $T_A = -20$  to  $70^\circ\text{C}$  (4 to 20 MHz)

Parameter	Symbol	Variable		16 MHz		20 MHz		Unit
		Min	Max	Min	Max	Min	Max	
SCLK cycle (programmable)	$t_{SCY}$	16X	8192X	1	512	0.8	409.6	$\mu\text{s}$
Output Data → SCLK rising edge	$t_{OSS}$	$t_{SCY} - 2X - 150$		725		550		ns
SCLK rising edge → Output Data hold	$t_{OHS}$	$2X - 80$		45		20		ns
SCLK rising edge → Input Data hold	$t_{HSR}$	0		0		0		ns
SCLK rising edge → effective data input	$t_{SRD}$			$t_{SCY} - 2X - 150$	725		550	ns

## 4.6 Timer/Counter Input Clock (TI0, TI4, TI5, TI6, TI7)

 $V_{CC} = 5V \pm 10\%$ ,  $T_A = -40$  to  $85^\circ\text{C}$  (4 to 16 MHz)  $T_A = -20$  to  $70^\circ\text{C}$  (4 to 20 MHz)

Parameter	Symbol	Variable		16 MHz		20 MHz		Unit
		Min	Max	Min	Max	Min	Max	
Clock Cycle	$t_{VCK}$	$8X + 100$		600		500		ns
Low level clock Pulse width	$t_{VCKL}$	$4X + 40$		290		240		ns
High level clock Pulse width	$t_{VCKH}$	$4X + 40$		290		240		ns

## 4.7 Interrupt Operation

 $V_{CC} = 5V \pm 10\%$ ,  $T_A = -40$  to  $85^\circ\text{C}$  (4 to 16 MHz)  $T_A = -20$  to  $70^\circ\text{C}$  (4 to 20 MHz)

Parameter	Symbol	Variable		16 MHz		20 MHz		Unit
		Min	Max	Min	Max	Min	Max	
NMI, INT0 Low level Pulse width	$t_{INTAL}$	4X		250		200		ns
NMI, INT0 High level Pulse width	$t_{INTAH}$	4X		250		200		ns
INT4 to INT7 Low level Pulse width	$t_{INTBL}$	$8X + 100$		600		500		ns
INT4 to INT7 High level Pulse width	$t_{INTBH}$	$8X + 100$		600		500		ns



4.8 Timing Chart for I/O Interface Mode

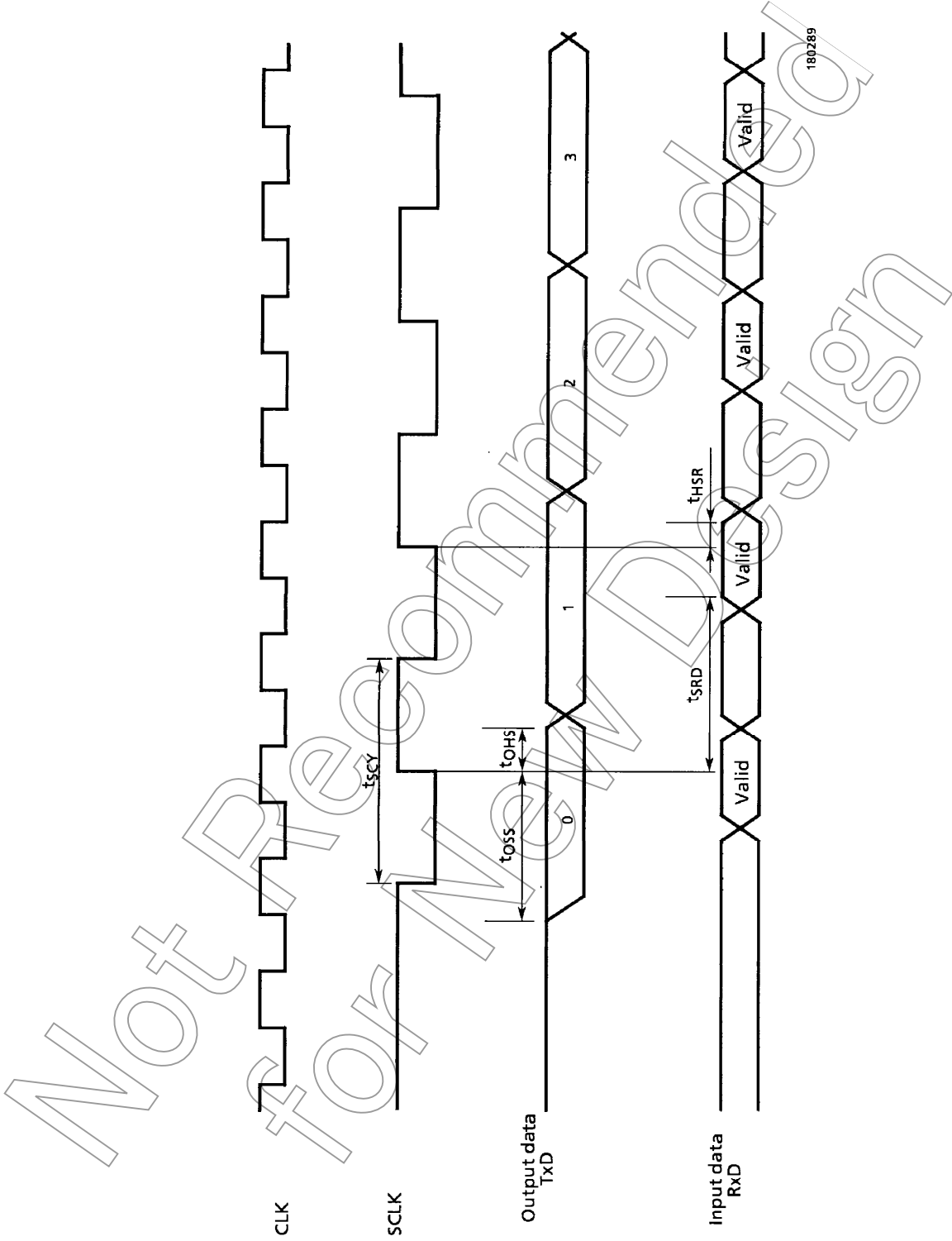

4.9 Timing Chart for Bus Request ( $\overline{\text{BUSRQ}}$ ) / BUS Acknowledge ( $\overline{\text{BUSAK}}$ )

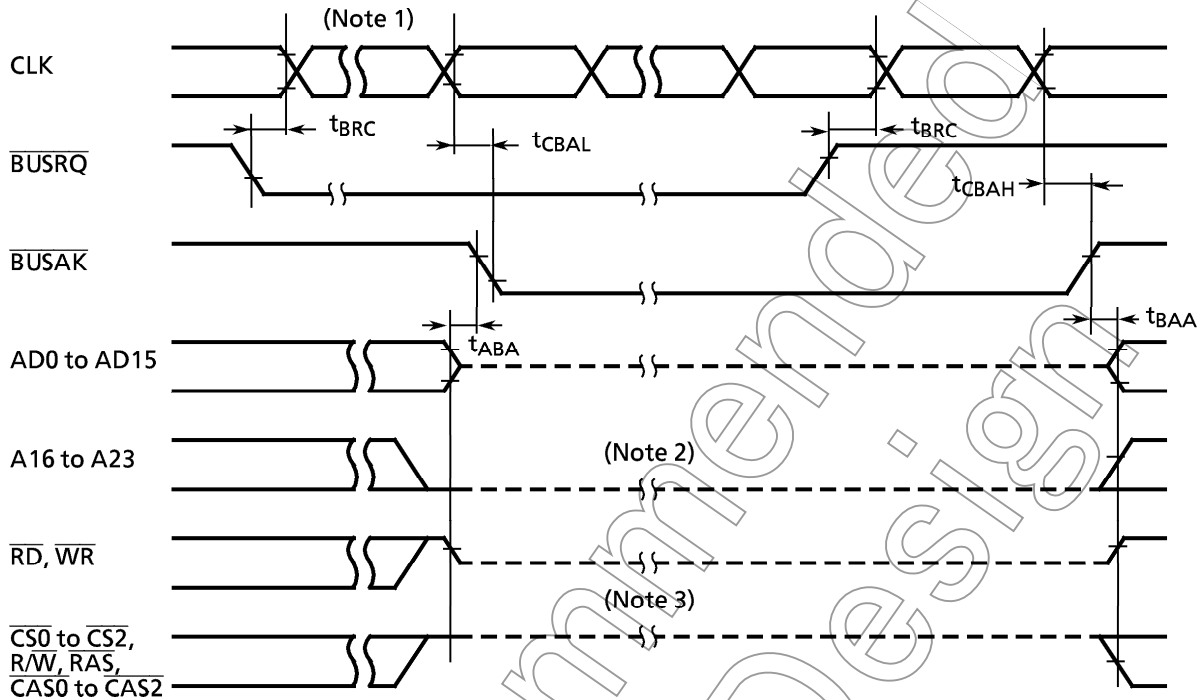

Symbol	Parameter	Variable		16 MHz		20 MHz		Unit
		Min	Max	Min	Max	Min	Max	
$t_{BRC}$	$\overline{\text{BUSRQ}}$ set-up time for CLK	120		120		120		ns
$t_{CBAL}$	CLK → $\overline{\text{BUSAK}}$ falling edge		$2.0x + 120$		245		220	ns
$t_{CBAH}$	CLK → $\overline{\text{BUSAK}}$ rising edge		$0.5x + 40$		71		65	ns
$t_{ABA}$	Output Buffer is off to $\overline{\text{BUSAK}}$	0	80	0	80	0	80	ns
$t_{BAA}$	$\overline{\text{BUSAK}}$ to Output buffer is on.	0	80	0	80	0	80	ns

Note 1: The Bus will be released after the WAIT request is inactive, when the  $\overline{\text{BUSRQ}}$  is set to "0" during "Wait" cycle.

Note 2: The internal programmable pull-down resistance is attached.

Note 3: The internal programmable pull-up resistance is attached.

CS2/CAS2 pin doesn't have programmable resistance. But pull-up resistance is attached, when bus is released.

4.10 Typical characteristics

$V_{CC}=5\text{ V}$ ,  $T_a=25^\circ\text{C}$ , unless otherwise noted.

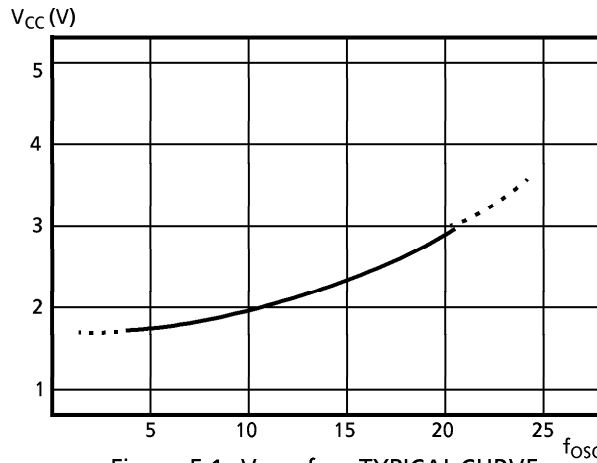

Figure 5.1  $V_{CC} - f_{osc}$  TYPICAL CURVE

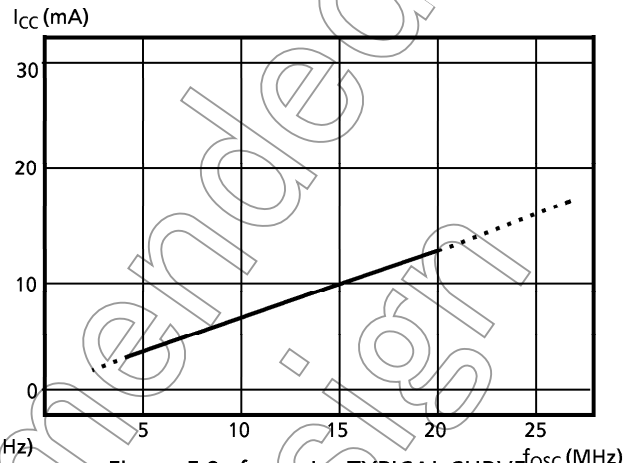

Figure 5.2  $f_{osc} - I_{CC}$  TYPICAL CURVE

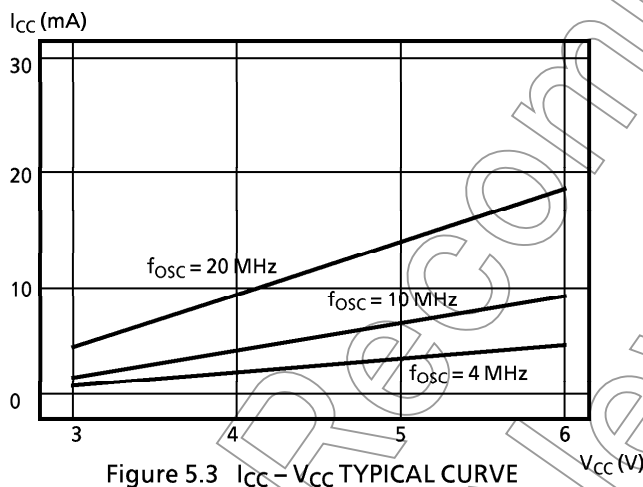

Figure 5.3  $I_{CC} - V_{CC}$  TYPICAL CURVE

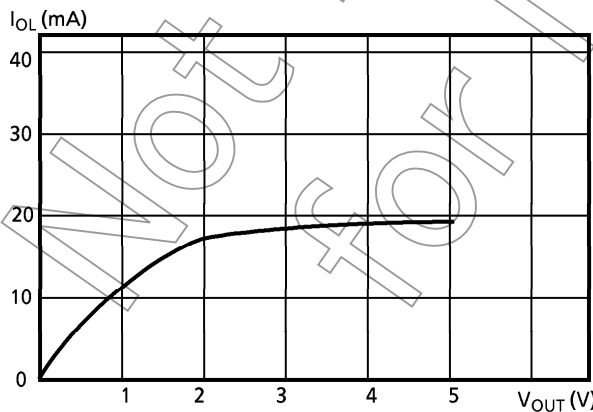

Figure 5.4  $V_{OUT} - I_{OL}$  TYPICAL CURVE

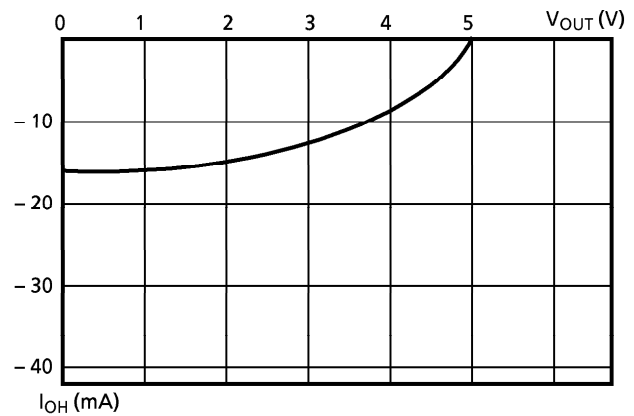

Figure 5.5  $V_{OUT} - I_{OH}$  TYPICAL CURVE

## 5. Table of Special Function Registers (SFRs)

(SFR ; Special Function Register)

The special function registers (SFRs) include the I/O ports and peripheral control registers allocated to the 128-byte addresses from 000000H to 00007FH.

- (1) I/O port
- (2) I/O port control
- (3) Timer control
- (4) Pattern Generator control
- (5) Watch Dog Timer control
- (6) Serial Channel control
- (7) A / D converter control
- (8) Interrupt control
- (9) Chip Select / Wait control

Configuration of the table

Symbol	Name	Address	7	6	5	4	3	2	1	0	
											→ bit Symbol
											→ Read / Write
											→ Initial value after reset
											→ Remarks

Not Recommended for New Design

Table5 I/O register address map

Address	Name	Address	Name	Address	Name	Address	Name
000000H	P0	20H	TRUN	40H	TREG6L	60H	ADREG0L
1H	P1	21H		41H	TREG6H	61H	ADREG0H
2H	P0CR	22H	TREG0	42H	TREG7L	62H	ADREG1L
3H		23H	TREG1	43H	TREG7H	63H	ADREG1H
4H	P1CR	24H	TMOD	44H	CAP3L	64H	ADREG2L
5H	P1FC	25H	TFFCR	45H	CAP3H	65H	ADREG2H
6H	P2	26H	TREG2	46H	CAP4L	66H	ADREG3L
7H	P3	27H	TREG3	47H	CAP4H	67H	ADREG3H
8H	P2CR	28H	P0MOD	48H	T5MOD	68H	BOCS
9H	P2FC	29H	P1MOD	49H	T5FFCR	69H	B1CS
AH	P3CR	2AH	PFFCR	4AH		6AH	B2CS
BH	P3FC	2BH		4BH		6BH	
CH	P4	2CH		4CH	PG0REG	6CH	
DH	P5	2DH		4DH	PG1REG	6DH	
EH	P4CR	2EH		4EH	PG01CR	6EH	
FH		2FH		4FH		6FH	
10H	P4FC	30H	TREG4L	50H	SC0BUF	70H	INTE0AD
11H		31H	TREG4H	51H	SC0CR	71H	INTE45
12H	P6	32H	TREG5L	52H	SC0MOD	72H	INTE67
13H	P7	33H	TREG5H	53H	BR0CR	73H	INTE10
14H	P6CR	34H	CAP1L	54H	SC1BUF	74H	INTEPW10
15H	P7CR	35H	CAP1H	55H	SC1CR	75H	INTE54
16H	P6FC	36H	CAP2L	56H	SC1MOD	76H	INTE76
17H	P7FC	37H	CAP2H	57H	BR1CR	77H	INTE50
18H	P8	38H	T4MOD	58H	ODE	78H	INTE51
19H	P9	39H	TFF4CR	59H		79H	
1AH	P8CR	3AH	T45CR	5AH		7AH	
1BH	P9CR	3BH		5BH		7BH	IIMC
1CH	P8FC	3CH		5CH	WDMOD	7CH	DMA0V
1DH	P9FC	3DH		5DH	WDCR	7DH	DMA1V
1EH		3EH		5EH	ADMOD	7EH	DMA2V
1FH		3FH		5FH		7FH	DMA3V

Note: TMP96C141B/041B doesn't have P0, P1, P0CR, P1CR, P1FC registers.

## (1) I/O Port

Symbol	Name	Address	7	6	5	4	3	2	1	0				
P0	PORT0	00H	P07	P06	P05	P04	P03	P02	P01	P00				
			R/W											
			Input mode Undefined											
P1	PORT1	01H	P17	P16	P15	P14	P13	P12	P11	P10				
			R/W											
			Input mode 0 0 0 0 0 0 0 0											
P2	PORT2	06H	P27	P26	P25	P24	P23	P22	P21	P20				
			* R/W											
			Input mode 0 0 0 0 0 0 0 0											
P3	PORT3	07H	P37	P36	P35	P34	P33	P32	P31	P30				
			* R/W											
			Input mode				Output mode 1 1 1 1 1 1 1 1							
P4	PORT4	0CH							P42	P41	P40			
			* R/W											
			Input mode 0 1 1 1											
P5	PORT5	0DH							P53	P52	P51	P50		
			R											
			Input mode											
P6	PORT6	12H	P67	P66	P65	P64	P63	P62	P61	P60				
			* R/W											
			Input mode 1 1 1 1 1 1 1 1											
P7	PORT7	13H							P73	P72	P71	P70		
			* R/W											
			Input mode 1 1 1 1											
P8	PORT8	18H	P87	P86	P85	P84	P83	P82	P81	P80				
			* R/W											
			Input mode 1 1 1 1 1 1 1 1											
P9	PORT9	19H							P95	P94	P93	P92	P91	P90
			* R/W											
			Input mode 1 1 1 1 1 1 1 1											

Note : When P30 pin is defined as  $\overline{RD}$  signal output mode (P30F = 1), clearing the output latch register P30 to "0" outputs the  $\overline{RD}$  strobe from P30 pin for PSRAM, even when the internal address is accessed. If the output latch register P30 remains "1", the  $\overline{RD}$  strobe is output only when the external address is accessed.

## Read/Write

R/W ; Either read or write is possible

R ; Only read is possible

W ; Only write is possible

Prohibit RMW ; Prohibit Read Modify Write. (Cannot use the RES, SET, TEST, CHG, STCF, EX, ADD, ADC, SUB, SBC, INC, DEC, RLC, RRC, RL, RR, SLA, SRA, SLL, SRL, RLD, RRD, AND, OR, or XOR instructions.)

\*R/W ; RMW instructions are prohibited for controlling ON/OFF of the pull-up/pull-down resistors.

## (2) I/O Port Control (1/2)

Symbol	Name	Address	7	6	5	4	3	2	1	0		
P0CR	PORT0 Control (Prohibit RMW)	02H	P07C	P06C	P05C	P04C	P03C	P02C	P01C	P00C		
			W							0	0	0
			0 : IN 1 : OUT (When external access, set as AD7-0 and cleared to "0".)									
P1CR	PORT1 Control (Prohibit RMW)	04H	P17C	P16C	P15C	P14C	P13C	P12C	P11C	P10C		
			W							0	0	0
			<< Refer to the "P1FC" >>									
P1FC	PORT1 Function (Prohibit RMW)	05H	P17F	P16F	P15F	P14F	P13F	P12F	P11F	P10F		
			W							0	0	0
			P1FC/P1CR = 00 : IN, 01 : OUT, 10 : AD15-8, 11 : A15-8									
P2CR	PORT2 Control (Prohibit RMW)	08H	P27C	P26C	P25C	P24C	P23C	P22C	P21C	P20C		
			W							0	0	0
			<< Refer to the "P2FC" >>									
P2FC	PORT2 Function (Prohibit RMW)	09H	P27F	P26F	P25F	P24F	P23F	P22F	P21F	P20F		
			W							0	0	0
			P2FC/P2CR = 00 : IN, 01 : OUT, 10 : A7-0, 11 : A23-16									
P3CR	PORT3 Control (Prohibit RMW)	0AH	P37C	P36C	P35C	P34C	P33C	P32C				
			W							0	0	
			0 : IN 1 : OUT									
P3FC	PORT3 Function (Prohibit RMW)	0BH	P37F	P36F	P35F	P34F		P32F	P31F	P30F		
			W							0	0	0
			0 : PORT 1 : RAS	0 : PORT 1 : R/W	0 : PORT 1 : BUSAK	0 : PORT 1 : BUSRQ		0 : PORT 1 : HWR	0 : PORT 1 : WR	0 : PORT 1 : RD		
P4CR	PORT4 Control (Prohibit RMW)	0EH						P42C	P41C	P40C		
										W	0	0
			0 : IN 1 : OUT									
P4FC	PORT4 Function (Prohibit RMW)	10H						P42F	P41F	P40F		
										W	0	0
			0 : PORT 1 : CS/CAS									

Note : With the TMP96C141B/TMP96C041B, which requires an external ROM, PORT0 functions as AD0 to AD7; PORT1, AD8 to AD15; P30, the  $\overline{RD}$  signal; P31, the  $\overline{WR}$  signal, regardless of the values set in P0CR, P1CR, P1FC, P30F and P31F.





(3) Timer Control (1/3)

Symbol	Name	Address	7	6	5	4	3	2	1	0			
TRUN	Timer Control	20H	PRRUN		T5RUN	T4RUN	P1RUN	P0RUN	T1RUN	T0RUN			
			R/W										
			0		0	0	0	0	0	0	0		
Prescaler & Timer Run/Stop CONTROL 0 : Stop & Clear 1 : Run (Count up)													
TREG0	8bit Timer Register 0	22H (Prohibit RMW)	-								W		
Undefined													
TREG1	8bit Timer Register 1	23H (Prohibit RMW)	-								W		
Undefined													
TMOD	8bit Timer Source CLK & MODE	24H (Prohibit RMW)	T10M1	T10M0	PWMM1	PWMM0	T1CLK1	T1CLK0	T0CLK1	T0CLK0			
			W										
			0	0	0	0	0	0	0	0	0		
			00 : 8bit Timer 01 : 16bit Timer 10 : 8bit PPG 11 : 8bit PWM		00 : - 01 : 2 <sup>6</sup> -1 10 : 2 <sup>7</sup> -1 11 : 2 <sup>8</sup> -1	PWM	00 : T00TRG 01 : φT1 10 : φT16 11 : φT256		00 : T10 Input 01 : φT1 10 : φT4 11 : φT16				
TFFCR	8bit Timer Flip-Flop Control	25H			DBEN	TFF1C1	TFF1C0	TFF1IE	TFF1IS				
					R/W	W		R/W					
					0	-	0	0					
		1 : Double Buffer Enable	00 : Invert TFF1 01 : Set TFF1 10 : Clear TFF1 11 : Don't care	1 : TFF1 Invert Enable	0 : Inverted by Timer 0								
TREG2	PWM Timer Register 2	26H	-								(R/W) (Can read register buffer values.)		
Undefined													
TREG3	PWM Timer Register 3	27H	-								(R/W) (Can read register buffer values.)		
Undefined													
P0MOD	PWM0 Mode	28H (Prohibit RMW)	FF2RD	DB2EN	PWM0INT	PWM0M	T2CLK1	T2CLK0	PWM0S1	PWM0S0			
			R	W									
			-	0	0	0	0	0	0	0			
			TFF2 output value	1 : Double Buffer Enable	0 : Overflow interrupt 1 : Compare match interrupt	0 : PWM Mode 1 : Timer Mode	00 : φP1 (fc/4) 01 : φP4 (fc/16) 10 : φP16 (fc/64) 11 : Don't care	00 : 2 <sup>6</sup> -1 01 : 2 <sup>7</sup> -1 10 : 2 <sup>8</sup> -1 11 : Don't care					
P1MOD	PWM1 Mode	29H (Prohibit RMW)	FF3RD	DB3EN	PWM1INT	PWM1M	T3CLK1	T3CLK0	PWM1S1	PWM1S0			
			R	W									
			-	0	0	0	0	0	0	0			
			TFF3 output value	1 : Double Buffer Enable	0 : Overflow interrupt 1 : Compare match interrupt	0 : PWM Mode 1 : Timer Mode	00 : φP1 (fc/4) 01 : φP4 (fc/16) 10 : φP16 (fc/64) 11 : Don't care	00 : 2 <sup>6</sup> -1 01 : 2 <sup>7</sup> -1 10 : 2 <sup>8</sup> -1 11 : Don't care					

Timer Control (2/3)

Symbol	Name	Address	7		6		5		4		3		2		1		0	
			FF3C1	FF3C0	FF3TRG1	FF3TRG0	FF2C1	FF2C0	FF2TRG1	FF2TRG0								
PFFCR	PWM Flip-Flop Control	2AH	W		R/W		W		R/W		W		R/W		W		R/W	
			-		0		0		-		-		0		0		0	
			00 : Don't care 01 : Set TFF3 10 : Clear TFF3 11 : Don't care		00 : Prohibit TFF3 inverted 01 : Invert if matched 10 : Set if matched; clear if overflowed 11 : Clear if matched; set if overflowed		00 : Don't care 01 : Set TFF2 10 : Clear TFF2 11 : Don't care		00 : Prohibit TFF2 inverted 01 : Invert if matched 10 : Set if matched; clear if overflowed 11 : Clear if matched; set if overflowed									
TREG4L	16bit Timer Register4L	30H (Prohibit RMW)	-		-		W		Undefined		-		-		-		-	
TREG4H	16bit Timer Register4H	31H (Prohibit RMW)	-		-		W		Undefined		-		-		-		-	
TREG5L	16bit Timer Register5L	32H (Prohibit RMW)	-		-		W		Undefined		-		-		-		-	
TREG5H	16bit Timer Register5H	33H (Prohibit RMW)	-		-		W		Undefined		-		-		-		-	
CAP1L	Capture Register1L	34H	-		-		R		Undefined		-		-		-		-	
CAP1H	Capture Register1H	35H	-		-		R		Undefined		-		-		-		-	
CAP2L	Capture Register2L	36H	-		-		R		Undefined		-		-		-		-	
CAP2H	Capture Register2H	37H	-		-		R		Undefined		-		-		-		-	
T4MOD	16bit Timer 4 Source CLK & MODE	38H	CAP2T5	EQ5T5	CAP1IN	CAP12M1	CAP12M0	CLE	T4CLK1	T4CLK0								
			R/W		W			R/W										
			0	0	0	0	0	0	0	0	0	0						
			TFF5 INV TRG 0 : TRG Disable 1 : TRG Enable		0 : Soft-Capture 1 : Don't care		Capture Timing 00 : Disable 01 : TI4 ↑ TI5 ↑ 10 : TI4 ↑ TI4 ↓ 11 : TFF1 ↑ TFF1 ↓			1 : UC4 Clear Enable		Source Clock 00 : TI4 01 : φT1 10 : φT4 11 : φT16						
T4FFCR	16bit Timer 4 Flip-Flop Control	39H	TFF5C1	TFF5C0	CAP2T4	CAP1T4	EQ5T4	EQ4T4	TFF4C1	TFF4C0								
			W				R/W		W									
			-		0	0	0	0	-									
			00 : Invert TFF5 01 : Set TFF5 10 : Clear TFF5 11 : Don't care		TFF4 Invert Trigger 0 : Trigger Disable 1 : Trigger Enable			00 : Invert TFF4 01 : Set TFF4 10 : Clear TFF4 11 : Don't care										

Timer Control (3/3)

Symbol	Name	Address	7	6	5	4	3	2	1	0	
T45CR	T4, T5 Control	3AH	-				PG1T	PG0T	DB6EN	DB4EN	
			R/W						R/W		
			0				0	0	0	0	
			Fix at "0"				PG1 shift trigger 0 : Timer 0, 1 1 : Timer 5	PG0 shift trigger 0 : Timer 0, 1 1 : Timer 4	1 : Double Buffer Enable		
TREG6L	16bit Timer Register6L	40H (Prohibit RMW)	-				W			Undefined	
TREG6H	16bit Timer Register6H	41H (Prohibit RMW)	-				W			Undefined	
TREG7L	16bit Timer Register7L	42H (Prohibit RMW)	-				W			Undefined	
TREG7H	16bit Timer Register7H	43H (Prohibit RMW)	-				W			Undefined	
CAP3L	Capture Register3L	44H	-				R			Undefined	
CAP3H	Capture Register3H	45H	-				R			Undefined	
CAP4L	Capture Register4L	46H	-				R			Undefined	
CAP4H	Capture Register4H	47H	-				R			Undefined	
T5MOD	16bit Timer 5 Source CLK & MODE	48H			CAP3IN	CAP34M1	CAP34M0	CLE	T5CLK1	T5CLK0	
					W			R/W			
			0	0	0	0	0	0	0		
					0: Soft-Capture 1: Don't care		Capture Timing 00: Disable 01: T16 ↑ T17 ↓ 10: T16 ↑ T16 ↓ 11: TFF1 ↑ TFF1 ↓		Source Clock 00: T16 01: φT1 10: φT4 11: φT16		
T5FFCR	16bit Timer 5 Flip-Flop Control	49H			CAP4T6	CAP3T6	EQ7T6	EQ6T6	TFF6C1	TFF6C0	
										W	
			0	0	0	0					
						TFF6 Invert Trigger 0 : Trigger Disable 1 : Trigger Enable		00 : Invert TFF6 01 : Set TFF6 10 : Clear TFF6 11 : Don't care			

(4) Pattern Generator

Symbol	Name	Address	7	6	5	4	3	2	1	0		
PG0REG	PG0 Register (Prohibit RMW)	4CH	PG03	PG02	PG01	PG00	SA03	SA02	SA01	SA00		
			W				R/W					
			0	0	0	0	Undefined					
PG1REG	PG1 Register (Prohibit RMW)	4DH	PG13	PG12	PG11	PG10	SA13	SA12	SA11	SA10		
			W				R/W					
			0	0	0	0	Undefined					
PG01CR	PG0, 1 Control	4EH	PAT1	CCW1	PG1M	PG1TE	PAT0	CCW0	PG0M	PG0TE		
			R/W									
			0	0	0	0	0	0	0	0	0	
			0: 8bit write 1: 4bit write	0: Normal Rotation 1: Reverse Rotation	0: 4bit Step 1: 8bit Step	PG1 trigger input enable 1: Enable	0: 8bit write 1: 4bit write	0: Normal Rotation 1: Reverse Rotation	0: 4bit Step 1: 8bit Step	PG0 trigger input enable 1: Enable		

(5) Watch Dog Timer

Symbol	Name	Address	7	6	5	4	3	2	1	0		
WD-MOD	Watch Dog Timer Mode	5CH	WDTE	WDTP1	WDTP0	WARM	HALTM1	HALTM0	RESCR	DRVE		
			R/W									
			1	0	0	0	0	0	0	0	0	
			1: WDT Enable	00: 2 <sup>16</sup> /fc 01: 2 <sup>18</sup> /fc 10: 2 <sup>20</sup> /fc 11: 2 <sup>22</sup> /fc	Warming up Time 0: 2 <sup>14</sup> /fc 1: 2 <sup>16</sup> /fc	Standby Mode 00: RUN Mode 01: STOP Mode 10: IDLE Mode 11: Don't care	1: Connect internally WDT out pin to Reset Pin	1: Drive the pin in STOP mode				
WDCR	Watch Dog Timer Control Register	5DH	W									
			-									
			B1H: WDT Disable Code					4EH: WDT Clear Code				

(6) Serial Channel (1/2)

Symbol	Name	Address	7	6	5	4	3	2	1	0	
SC0BUF	Serial Channel 0 Buffer	50H	RB7 TB7	RB6 TB6	RB5 TB5	RB4 TB4	RB3 TB3	RB2 TB2	RB1 RB1	RB0 TB0	
			R (Receiving)/W (Transmission)								
			Undefined								
SC0CR	Serial Channel 0 Control	51H	RB8	EVEN	PE	OERR	PERR	FERR	SCLKS	IOC	
			R	R/W		R (Cleared to 0 by reading)			R/W		
			0	0	0	0	0	0	0	0	
			Receiving data bit 8	Parity 0: Odd 1: Even	1: Parity Enable	Overrun	1: Error Parity	Framing	0: SCLK0 1: SCLK0	1: Input SCLK0 pin	
SC0-MOD	Serial Channel 0 Mode	52H	TB8	CTSE	RXE	WU	SM1	SM0	SC1	SC0	
			R/W								
			Undefined	0	0	0	0	0	0	0	
			Transmission data bit 8	1: CTS Enable	1: Receive Enable	1: Wake up Enable	00: Unused 01: UART 7bit 10: UART 8bit 11: UART 9bit	00: TO0 Trigger 01: Baud rate generator 10: Internal clock $\phi$ 1 11: Don't care			
BR0CR	Baud Rate Control	53H	-	BR0CK1		BR0CK0	BR0S3	BR0S2	BR0S1	BR0S0	
			R/W	R/W							
			0	0	0	0	0	0	0	0	
			Fix at "0"	00: $\phi$ T0 (fc/4) 01: $\phi$ T2 (fc/16) 10: $\phi$ T8 (fc/64) 11: $\phi$ T32 (fc/256)	Set frequency divisor 0~F ("1" prohibited)						
SC1BUF	Serial Channel 1 Buffer	54H	RB7 TB7	RB6 TB6	RB5 TB5	RB4 TB4	RB3 TB3	RB2 TB2	RB1 RB1	RB0 TB0	
			R (Receiving) /W (Transmission)								
			Undefined								
SC1CR	Serial Channel 1 Control	55H	RB8	EVEN	PE	OERR	PERR	FERR	SCLKS	IOC	
			R	R/W		R (Cleared to 0 by reading)			R/W		
			0	0	0	0	0	0	0	0	
			Receiving data bit 8	Parity 0: Odd 1: Even	1: Parity Enable	Overrun	1: Error Parity	Framing	0: SCLK1 1: SCLK1	1: Input SCLK1 pin	
SC1-MOD	Serial Channel 1 Mode	56H	TB8	-	RXE	WU	SM1	SM0	SC1	SC0	
			R/W								
			Undefined	0	0	0	0	0	0	0	
			Transmission data bit 8	Fix at "0"	1: Receive Enable	1: Wake up Enable	00: I/O Interface 01: UART 7bit 10: UART 8bit 11: UART 9bit	00: TO0 Trigger 01: Baud rate generator 10: Internal clock $\phi$ 1 11: Don't care			

(6) Serial Channel (2/2)

Symbol	Name	Address	7	6	5	4	3	2	1	0	
BR1CR	Baud Rate Control	57H	-		BR1CK1	BR1CK0	BR1S3	BR1S2	BR1S1	BR1S0	
			R/W								
			0		0	0	0	0	0	0	
			Fix at "0"		00: $\phi$ T0 (fc/4)	01: $\phi$ T2 (fc/16)	10: $\phi$ T8 (fc/64)	11: $\phi$ T32 (fc/256)	Set frequency divisor 0~F ("1" prohibited)		
ODE	Serial Open Drain Enable	58H							ODE1	ODE0	
										R/W	
										0	0
										1:P93 Open-drain	1:P90 Open-drain

(7) A/D Converter Control

Symbol	Name	Address	7	6	5	4	3	2	1	0
ADM0D	A/D Converter Mode reg	5EH	EOCF	ADBF	REPET	SCAN	ADCS	ADS	ADCH1	ADCH0
			R							
			0	0	0	0	0	0	0	0
			1: End	1: Busy	1: Repeat mode	1: Scan mode	1: Slow mode	1: START	Analog Input Channel Select	
*1) AD REG0L	AD Result Reg 0 low	60H	ADR01	ADR00						
			Undefined		1	1	1	1	1	1
AD REG0H	AD Result Reg 0 high	61H	ADR09	ADR08	ADR07	ADR06	ADR05	ADR04	ADR03	ADR02
			R							
			Undefined							
*1) AD REG1L	AD Result Reg 1 low	62H	ADR11	ADR10						
			Undefined		1	1	1	1	1	1
AD REG1H	AD Result Reg 1 high	63H	ADR19	ADR18	ADR17	ADR16	ADR15	ADR14	ADR13	ADR12
			R							
			Undefined							
*1) AD REG2L	AD Result Reg 2 low	64H	ADR21	ADR20						
			Undefined		1	1	1	1	1	1
AD REG2H	AD Result Reg 2 high	65H	ADR29	ADR28	ADR27	ADR26	ADR25	ADR24	ADR23	ADR22
			R							
			Undefined							
*1) AD REG3L	AD Result Reg 3 low	66H	ADR31	ADR30						
			Undefined		1	1	1	1	1	1
AD REG3H	AD Result Reg 3 high	67H	ADR39	ADR38	ADR37	ADR36	ADR35	ADR34	ADR33	ADR32
			R							
			Undefined							

\*1: Data to be stored in A/D Conversion Result Reg Low are the lower 2 bits of the conversion result. The contents of the lower 6 bits of this register are always read as "1".

(8) Interrupt Control (1/2)

Symbol	Name	Address	7	6	5	4	3	2	1	0
INTE-0AD	INTerrupt Enable 0 & A/D	70H (Prohibit RMW)	INTAD				INT0			
			IADC	IADM2	IADM1	IADM0	IOC	IOM2	IOM1	IOM0
			R/W	W			R/W	W		
			0	0	0	0	0	0	0	0
INTE45	INTerrupt Enable 4/5	71H (Prohibit RMW)	INT5				INT4			
			I5C	I5M2	I5M1	I5M0	I4C	I4M2	I4M1	I4M0
			R/W	W			R/W	W		
			0	0	0	0	0	0	0	0
INTE67	INTerrupt Enable 6/7	72H (Prohibit RMW)	INT7				INT6			
			I7C	I7M2	I7M1	I7M0	I6C	I6M2	I6M1	I6M0
			R/W	W			R/W	W		
			0	0	0	0	0	0	0	0
INTE10	INTerrupt Enable Timer 1/0	73H (Prohibit RMW)	INTT1 (Timer 1)				INTT0 (Timer 0)			
			IT1C	IT1M2	IT1M1	IT1M0	IT0C	IT0M2	IT0M1	IT0M0
			R/W	W			R/W	W		
			0	0	0	0	0	0	0	0
INTE-PW10	INTerrupt Enable PWm 1/0	74H (Prohibit RMW)	INTT3 (Timer 3/PWM1)				INTT2 (Timer 2/PWM0)			
			IPW1C	IPW1M2	IPW1M1	IPW1M0	IPW0C	IPW0M2	IPW0M1	IPW0M0
			R/W	W			R/W	W		
			0	0	0	0	0	0	0	0
INTE54	INTerrupt Enable Treg 5/4	75H (Prohibit RMW)	INTTR5 (TREG5)				INTTR4 (TREG4)			
			IT5C	IT5M2	IT5M1	IT5M0	IT4C	IT4M2	IT4M1	IT4M0
			R/W	W			R/W	W		
			0	0	0	0	0	0	0	0
INTE76	INTerrupt Enable Treg 7/6	76H (Prohibit RMW)	INTTR7 (TREG7)				INTTR6 (TREG6)			
			IT7C	IT7M2	IT7M1	IT7M0	IT6C	IT6M2	IT6M1	IT6M0
			R/W	W			R/W	W		
			0	0	0	0	0	0	0	0
INTES0	INTerrupt Enable Serial 0	77H (Prohibit RMW)	INTTX0				INTRX0			
			ITX0C	ITX0M2	ITX0M1	ITX0M0	IRX0C	IRX0M2	IRX0M1	IRX0M0
			R/W	W			R/W	W		
			0	0	0	0	0	0	0	0
INTES1	INTerrupt Enable Serial 1	78H (Prohibit RMW)	INTTX1				INTRX1			
			ITX1C	ITX1M2	ITX1M1	ITX1M0	IRX1C	IRX1M2	IRX1M1	IRX1M0
			R/W	W			R/W	W		
			0	0	0	0	0	0	0	0

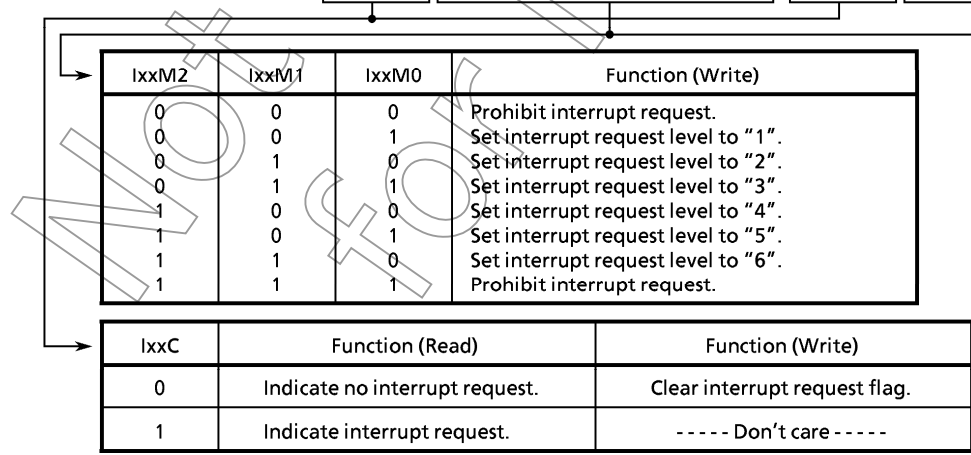

Interrupt Control (2/2)

Symbol	Name	Address	7	6	5	4	3	2	1	0
DMA0V	DMA 0 request Vector	7CH (Prohibit RMW)	μDMA0 start vector							
			DMA0V8	DMA0V7	DMA0V6	DMA0V5	DMA0V4			
			W							
			0	0	0	0	0			
DMA1V	DMA 1 request Vector	7DH (Prohibit RMW)	μDMA1 start vector							
			DMA1V8	DMA1V7	DMA1V6	DMA1V5	DMA1V4			
			W							
			0	0	0	0	0			
DMA2V	DMA 2 request Vector	7EH (Prohibit RMW)	μDMA2 start vector							
			DMA2V8	DMA2V7	DMA2V6	DMA2V5	DMA2V4			
			W							
			0	0	0	0	0			
DMA3V	DMA 3 request Vector	7FH (Prohibit RMW)	μDMA3 start vector							
			DMA3V8	DMA3V7	DMA3V6	DMA3V5	DMA3V4			
			W							
			0	0	0	0	0			
IIMC	Interrupt Input Mode Control	7BH (Prohibit RMW)	IOIE							
			W							
			0							
			1: INTO input enable							
IOLE								NMIREE		
W								W		
0								0		
1: INTO edge mode								1: Operate even at NMI rise edge		
1: INTO level mode										

Not Recommended for New Design



## (9) Chip Select / Wait Controller

Symbol	Name	Address	7	6	5	4	3	2	1	0
B0CS	Block 0 CS/WAIT control register	68H  (Prohibit RMW)	B0E	B0SYS	B0CAS	B0BUS	B0W1	B0W0	B0C1	B0C0
			W	W	W	W	W	W	W	W
			0	0	0	0	0	0	0	0
			1: CS Enable	1: SYSTEM only	0: CS0 1: CAS0	0: 16bit Bus 1: 8bit Bus	00: 2WAIT 01: 1WAIT 10: 1WAIT + n 11: 0WAIT	00: 7F00H to 7FFFH 01: 400000H to 10: 800000 to 11: C00000 to		
B1CS	Block 1 CS/WAIT control register	69H  (Prohibit RMW)	B1E	B1SYS	B1CAS	B1BUS	B1W1	B1W0	B1C1	B1C0
			W	W	W	W	W	W	W	W
			0	0	0	0	0	0	0	0
			1: CS Enable	1: SYSTEM only	0: CS1 1: CAS1	0: 16bit Bus 1: 8bit Bus	00: 2WAIT 01: 1WAIT 10: 1WAIT + n 11: 0WAIT	00: 480H to 7FFFH (Note3) 01: 400000H to 10: 800000H to 11: C00000H to		
B2CS	Block 2 CS/WAIT control register	6AH  (Prohibit RMW)	B2E	B2SYS	B2CAS	B2BUS	B2W1	B2W0	B2C1	B2C0
			W	W	W	W	W	W	W	W
			1	0	0	0	0	0	0	0
			1: CS Enable	1: SYSTEM only	0: CS2 1: CAS2	0: 16bit Bus 1: 8bit Bus	00: 2WAIT 01: 1WAIT 10: 1WAIT + n 11: 0WAIT	00: 8000H to 01: 400000H to 10: 800000H to 11: C00000H to		

Note 1: After reset, only "Block 2" is set to enable.

→ After reset, the program starts in 16-bit data bus, 2-wait state.

Note 2: These registers can be accessed only in system mode.

Note 3: TMP96C041B for internal RAM less is 80H to 7FFFH.

Not Recommended for New

## 6. Port Section Equivalent Circuit Diagram

- Reading The Circuit Diagram

Basically, the gate symbols written are the same as those used for the standard CMOS logic IC [74HCXX] series.

The dedicated signal is described below.

**STOP** : This signal becomes active “1” when the halt mode setting register is set to the STOP mode and the CPU executes the HALT instruction. When the drive enable bit [DRIVE] is set to “1”, however, STOP remains at “0”.

- The input protection resistans ranges from several tens of ohms to several hundreds of ohms.

- P0 (AD0 to AD7), P1 (AD8 to 15, A8 to 15), P2(A16 to 23, A0 to 7)

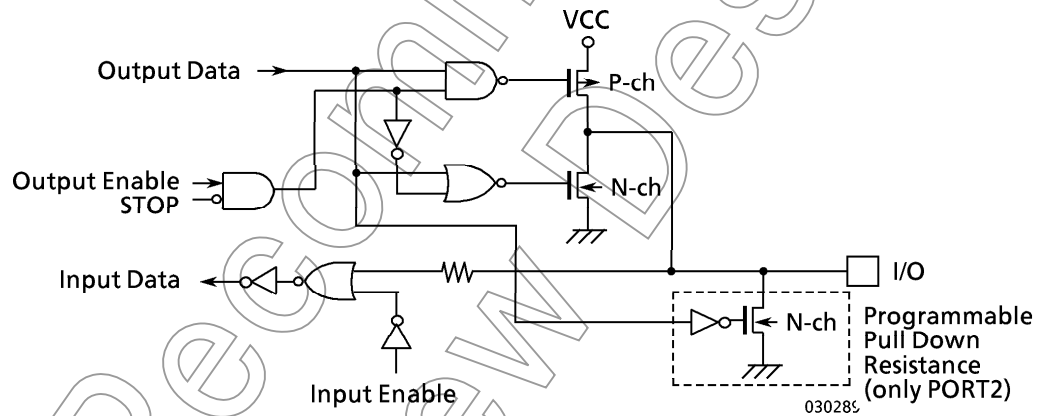

- P30(RD), P31(WR)

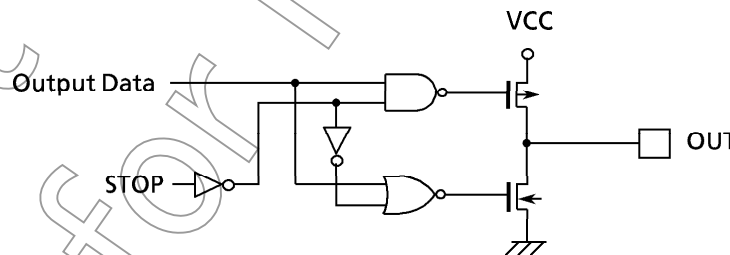

■ P32 to 37, P40, 41, P6, P7, P80 to 86, P91, 92, P94, 95

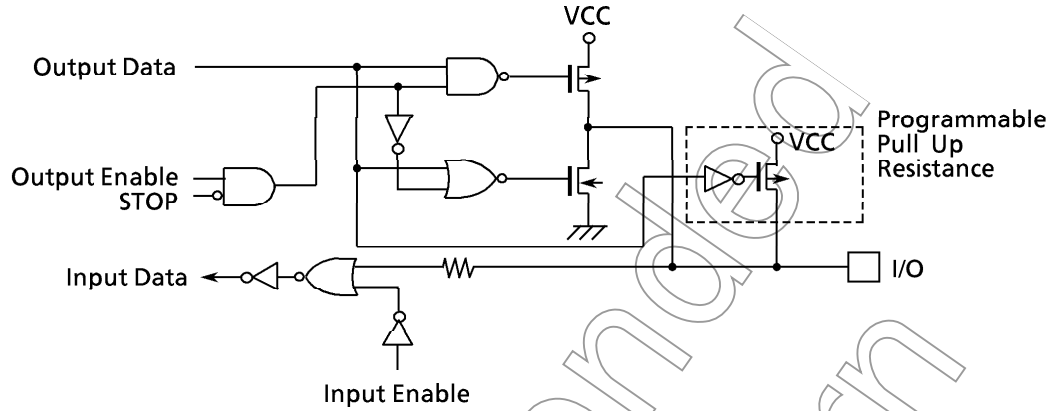

■ P42 ( $\overline{CS2}$ ,  $\overline{CAS2}$ )

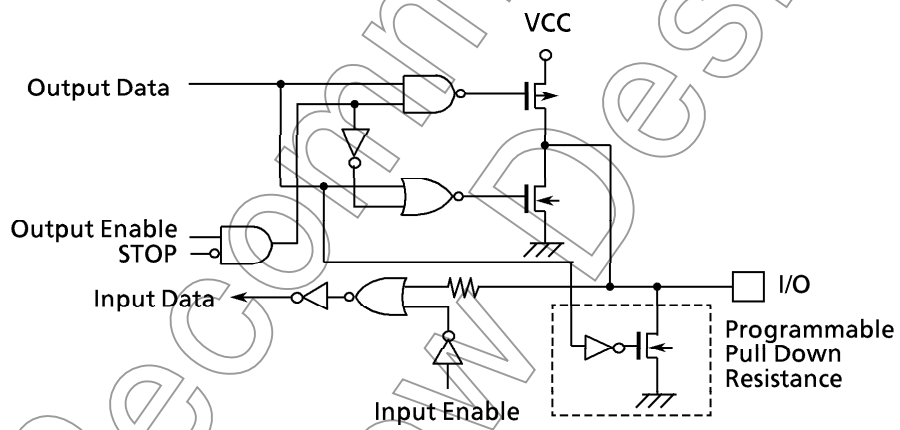

■ P5 (AN0 to 3)

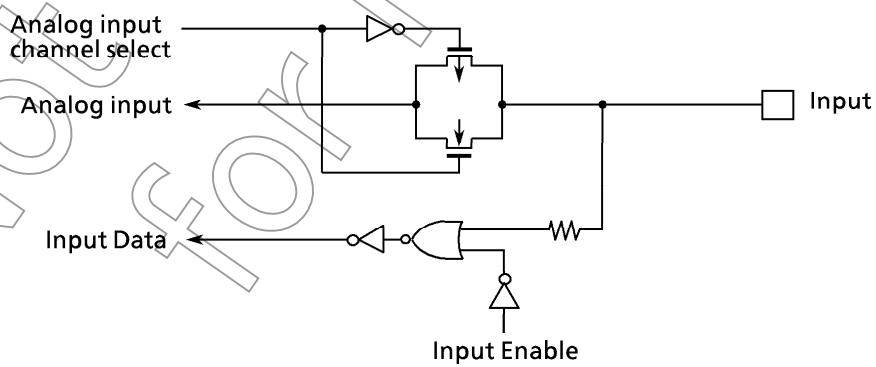

■ P87 (INT0)

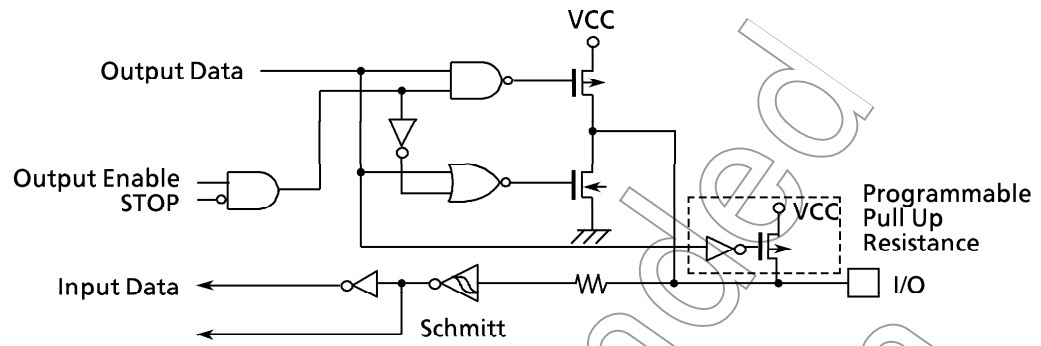

■ P90 (TXD0), P93 (TXD1)

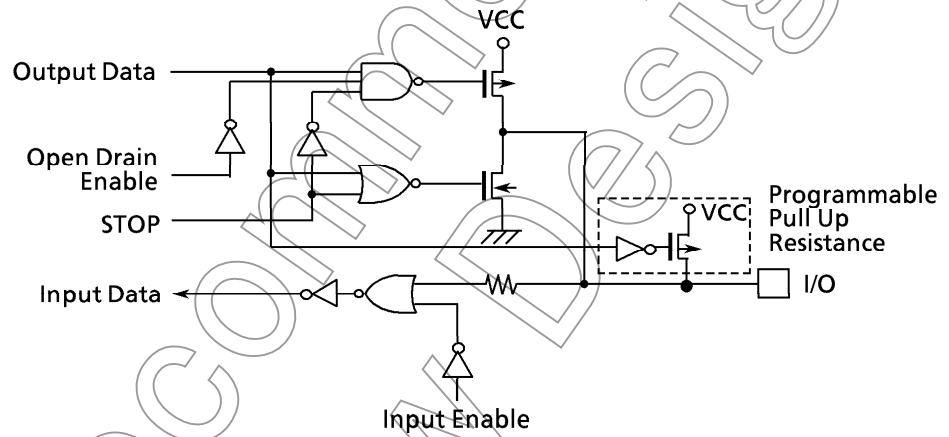

Not Recommended for New Design

■  $\overline{\text{NMI}}$

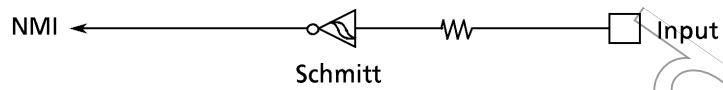

■  $\overline{\text{WDTOUT}}$

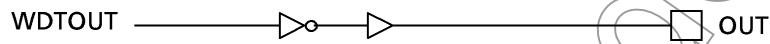

■ CLK

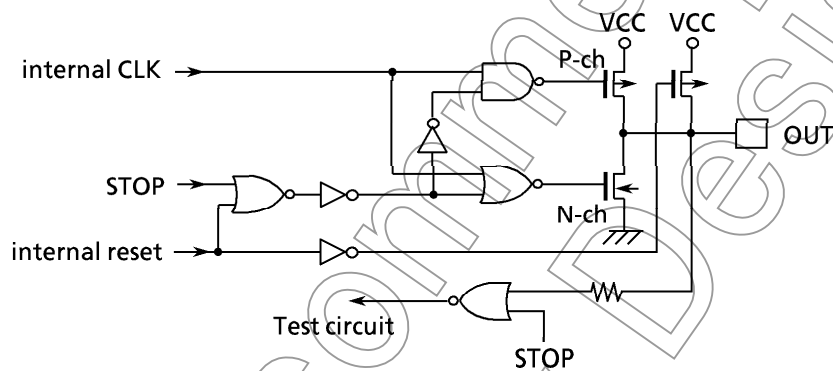

■  $\overline{\text{EA}}, \overline{\text{AM8/16}}$

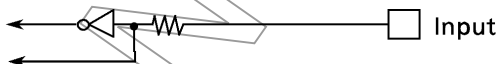

■ ALE

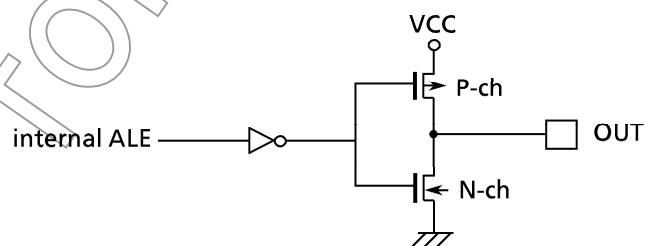

■  $\overline{\text{RESET}}$

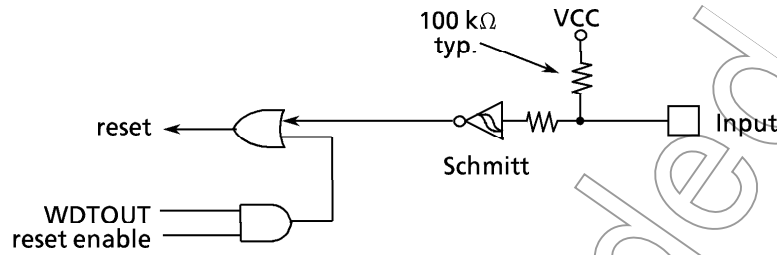

■ X1, X2

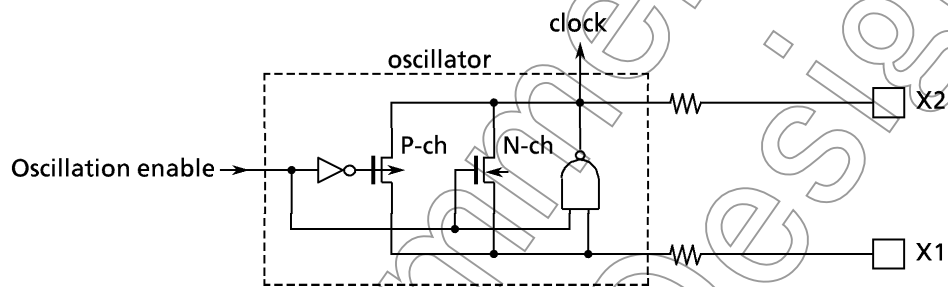

■ VREF, AGND

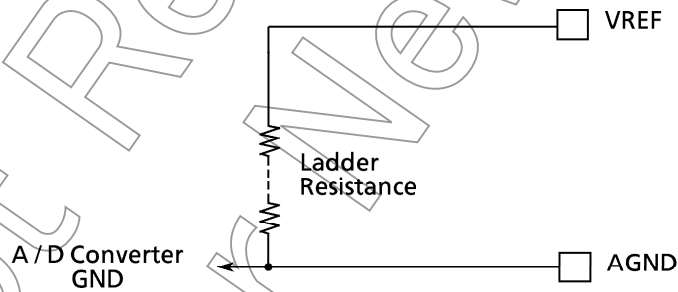

Not Recommended for New Design

## 7. Points of Note and Restrictions

### (1) Special Expression

① Explanation of a built-in I/O register : Register Symbol <Bit Symbol >

ex) TRUN <TORUN > ... Bit TORUN of Register TRUN

② Read, Modify and Write Instruction

An instruction which CPU executes following by one instruction.

1. CPU reads data of the memory.
2. CPU modifies the data.
3. CPU writes the data to the same memory.

ex1) SET 3, (TRUN) ... set bit3 of TRUN

ex2) INC 1, (100H) ... increment the data of 100H

● The representative Read, Modify and Write Instruction in the TLCS-900

SET imm, mem , RES imm, mem

CHG imm, mem , TSET imm, mem

INC imm, mem , DEC imm, mem

RLD A, mem , ADD imm, reg

③ 1 state

1 cycle clock divided by 2 oscillation frequency is called 1 state.

ex) The case of oscillation frequency is 20MHz

### (2) Care Points

①  $\overline{EA}$ , pin

Fix these pins V<sub>CC</sub> or GND unless changing voltage.

② Warmingup Counter

The warmingup counter operates when the STOP mode is released even the system which is used an external oscillator. As a result, it takes warming up time from inputting the releasing request to outputting the system clock.

③ High Speed  $\mu$ DMA (DRAM refresh mode)

When the Bus is released (BUSAK = "0") for waiting to accept the interrupt, DRAM refresh is not performed because of the high-speed  $\mu$ DMA is generated by an interrupt.

④ Programmable Pull Up/Down Resistance

The programmable pull up/down resistors can be selected ON/OFF by program when they are used as the input ports. The case of they are used as the output ports, they can not be selected ON/OFF by program. Read-modify-write instructions are prohibited for controlling ON/OFF of the pull-up/down resistors.

⑤ Bus Releasing Function

Refer to the “Note about the Bus Release” in 3.5 Functions of Ports because the pin state when the bus is released is written.

⑥ WatchDog Timer

When the bus is released, both internal memory and internal I/O can not be accessed. But the internal I/O continues to operate. So, the watch dog timer continues to run. Therefore, be care about the bus releasing time and set the detection timer of watch dog timer.

⑦ WatchDog Timer

The watch dog timer starts operation immediately after the reset is released. When the watch dog timer is not used, set watch dog timer to disable.

⑧ CPU (High Speed  $\mu$ DMA)

Only the “LDC cr, r”, “LDC r, cr” instruction can be used to access the control register like transfer source address register (DMASn) in the CPU.

⑨ Releasing the HALT mode by requesting an interruption

Usually, interrupts can release all halts status. However, the interrupts = ( $\overline{\text{NMI}}$ , INT0), which can release the HALT mode may not be able to do so if they are input during the period CPU is shifting to the HALT mode (for about 3 clocks of X1) with IDLE or STOP mode. (In this case, an interrupt request is kept on hold internally.)

If another interrupt is generated after it has shifted to HALT mode completely, halt status can be released without difficulty. The priority of this interrupt is compare with that of the interrupt kept on hold internally, and the interrupt with higher priority is handled first followed by the other interrupt.

Not  
for  
NEC



Not Recommended  
for New Design

## X-ON Electronics

Largest Supplier of Electrical and Electronic Components

*Click to view similar products for [16-bit Microcontrollers - MCU category](#):*

*Click to view products by [Toshiba manufacturer](#):*

Other Similar products are found below :

[MB90F036APMC-GSE1](#) [MB90F342CASPMC-GSE1](#) [MB90F345CESPMC-GE1](#) [MB90F349CAPFR-GSE1](#) [MB90F428GCPFR-GSE1](#)  
[MB90F462APFM-GE1](#) [MB90F462APMC-G-SNE1](#) [MB90F497GPF-GE1](#) [MB90F546GSPFR-GE1](#) [MB90F947APFR-GS-SPE1](#)  
[MB96F346RSBPMC-GS-N2E2](#) [MB96F683RBPMC-GSAE1](#) [R5F104ACASP#V0](#) [R5F11BGEAFB#30](#) [S912ZVFP64F1VLL](#)  
[R4F24268NVRFQV](#) [R5F11B7EANA#U0](#) [R5F21172DSP#U0](#) [M30622F8PGP#U3C](#) [MB90092PF-G-BNDE1](#) [MB90F335APMC1-G-SPE1](#)  
[MB90F342CASPF-R-GS-N2E1](#) [MB90F345CAPFR-GSE1](#) [MB90F543GPF-GE1](#) [MB90F546GSPF-GE1](#) [MB90F568PMCR-GE1](#)  
[MB90F594APFR-GE1](#) [MB90F882ASPMC-GE1](#) [MB96F346RSAPQCR-GS-N2E2](#) [MB96F387RSBPMC-GSE2](#) [MB96F387RSBPMC-GS-](#)  
[N2E2](#) [MB96F395RSAPMC-GSE2](#) [MB96F623RBPMC1-GSE1](#) [MB96F635RBPMC-GSE1](#) [MB96F646RBPMC-GSE1](#)  
[XE167F96F66LACFXUMA1](#) [MB96F696RBPMC-GSAE1](#) [MB96F635RBPMC-GSAE1](#) [MB96F018RBPMC-GSE1](#) [MB90F962SPMCR-GE1](#)  
[MB90F867ASPFR-GE1](#) [MB90F543GPF-G-FLE1](#) [MB90F345CESPF-GE1](#) [M30290FCHP#U3A](#) [HD64F3672FPV](#) [R5F104AEASP#V0](#)  
[R5F100BCANA#U0](#) [R5F100BFANA#U0](#) [R5F100ACASP#V0](#) [R5F117BCGFP#30](#)