



DC COMPONENTS CO., LTD.

RECTIFIER SPECIALISTS

**TBR3500
THRU
TBR3516**

TECHNICAL SPECIFICATIONS OF THREE-PHASE SILICON BRIDGE RECTIFIER

VOLTAGE RANGE - 50 to 1600 Volts

CURRENT - 35 Amperes

FEATURES

- * Diffused Junction
- * Low Forward Voltage Drop
- * High Current Capability
- * High Reliability
- * High Surge Current Capability
- * Ideal for Printed Circuit Boards

MECHANICAL DATA

- * Case: Molded plastic with heatsink
- * Epoxy: UL 94V-0 rate flame retardant
- * Terminals: Plated .25"(6.35mm) Faston lugs, Solderable per MIL-STD-202E, Method 208 guaranteed
- * Polarity: As marked
- * Mounting position: Any
- * Weight: 20 grams(approx.)

MAXIMUM RATINGS AND ELECTRICAL CHARACTERISTICS

Ratings at 25°C ambient temperature unless otherwise specified.
Single phase, half wave, 60 Hz, resistive or inductive load.
For capacitive load, derate current by 20%.

TBR

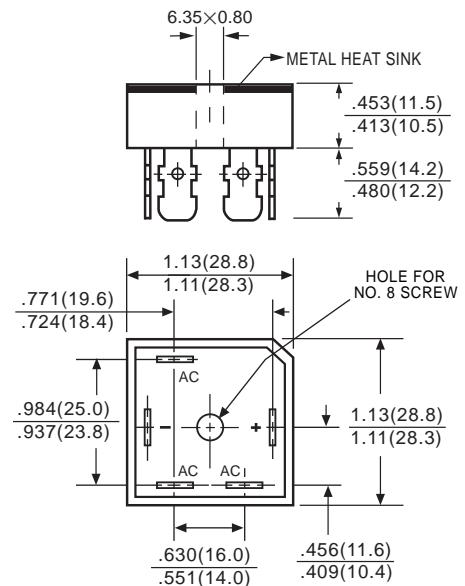

Dimensions in millimeters

		SYMBOL	TBR 3500	TBR 3501	TBR 3502	TBR 3504	TBR 3506	TBR 3508	TBR 3510	TBR 3512	TBR 3514	TBR 3516	UNITS
Maximum Recurrent Peak Reverse Voltage & DC Blocking Voltage		V_{RRM}, V_{DC}	50	100	200	400	600	800	1000	1200	1400	1600	Volts
Maximum RMS Bridge Input Voltage		V_{RMS}	35	70	140	280	420	560	700	840	980	1120	Volts
Peak Non-Repitative Reverse Voltage		V_{RSM}	75	150	275	500	725	900	1100	1300	1500	1700	Volts
Maximum Average Forward Rectified Output Current at $T_c = 60^\circ C$		I_o	35										Amps
Non-Repitative Peak Forward Surge Current	No Voltage Reapplied	$t=8.3ms$ at 60Hz	500										Amps
		$t=10ms$ at 50Hz	475										
	100% V_{RRM} Reapplied	$t=8.3ms$ at 60Hz	420										
		$t=10ms$ at 50Hz	400										
Forward Voltage(per element) @ $T_J=25^\circ C$, @ $I_{FM}=40A_{pk}$ per single junction		V_F	1.19										Volts
Maximum DC Reverse Current at Rated DC Blocking Voltage per element		@ $T_J = 25^\circ C$	10										uAmps
		@ $T_J = 125^\circ C$	5.0										mAmps
I^2t Rating for Fusing	No Voltage Reapplied	$t=8.3ms$ at 60Hz	1030										A ² Sec
		$t=10ms$ at 50Hz	1130										
	100% V_{RRM} Reapplied	$t=8.3ms$ at 60Hz	730										
		$t=10ms$ at 50Hz	800										
RMS Isolation Voltage from Case to Lead		V_{ISO}	2500										Volts
Thermal Resistance Case to Heatsink Mounting Surface, Smooth, Flat and Greased		$R_{\theta CS}$	0.2										K/W
Thermal Resistance Junction to Case at DC Operation per Bridge		$R_{\theta JC}$	1.16										K/W
Operating and Storage Temperature Range		T_J, T_{STG}	-40 to +150										°C

RATING AND CHARACTERISTIC CURVES (TBR3500 THRU TBR3516)

FIG. 1 - MAXIMUM NON-REPETITIVE SURGE CURRENT

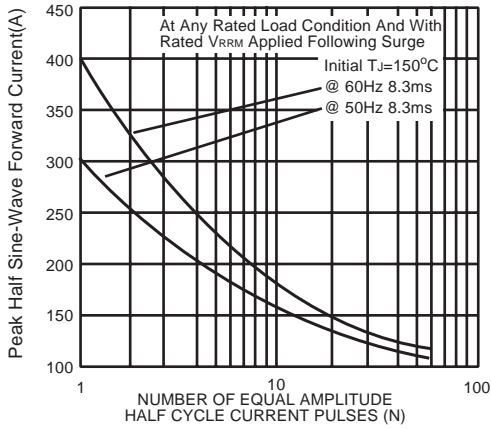

FIG. 2 - MAXIMUM NON-REPETITIVE SURGE CURRENT

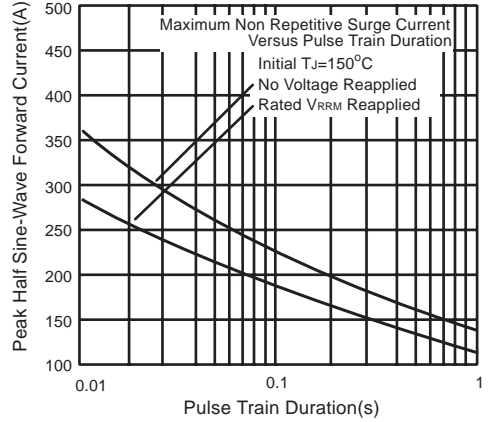

FIG. 3 - TOTAL POWER LOSS CHARACTERISTICS

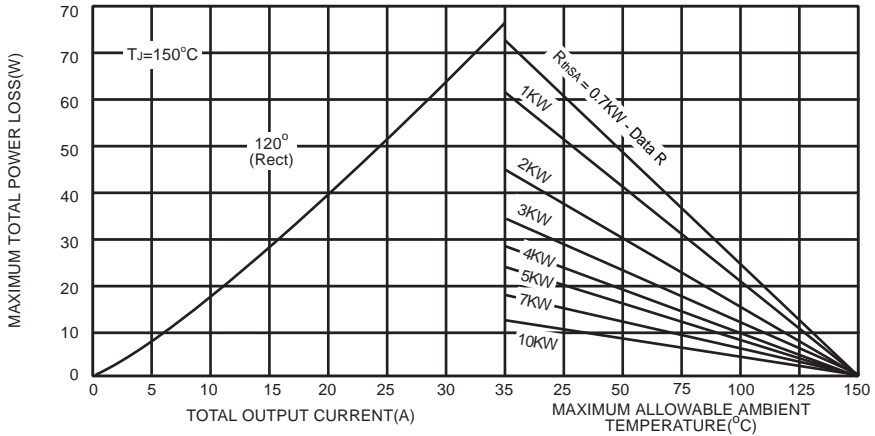

FIG. 4 - FORWARD VOLTAGE DROP CHARACTERISTICS

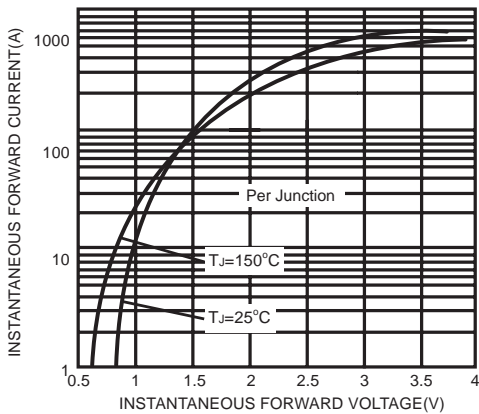
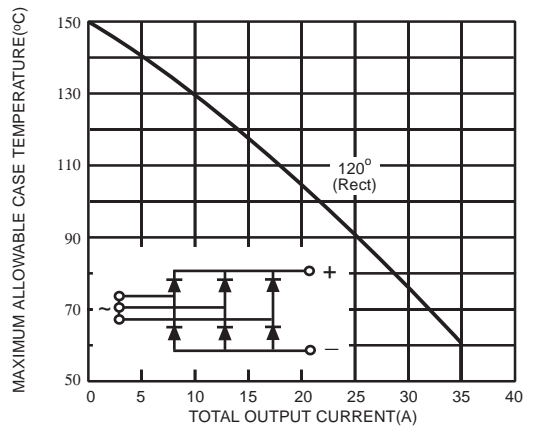

FIG. 5 - CURRENT RATINGS CHARACTERISTICS



X-ON Electronics

Largest Supplier of Electrical and Electronic Components

Click to view similar products for [Bridge Rectifiers](#) category:

Click to view products by [DC Components](#) manufacturer:

Other Similar products are found below :

[G3SBA60-E351](#) [GBJ1504-BP](#) [GBU10B-BP](#) [GBU15J-BP](#) [GBU15K-BP](#) [GBU4A-BP](#) [GBU4D-BP](#) [GBU6B-E3/45](#) [GSIB680-E3/45](#) [DB101-BP](#) [DF10SA-E345](#) [RMB2S](#) [RCG](#) [APT30DF100HJ](#) [APT60DF20HJ](#) [B2S-E3/80](#) [BU1506-E351](#) [BU15085S-E345](#) [BU1508-E3/45](#) [BU1510-E3/45](#) [RS404GL-BP](#) [RS405GL-BP](#) [G3SBA20-E3/51](#) [G5SBA20-E3/51](#) [G5SBA60-E3/51](#) [GBJ1502-BP](#) [GBL02-E351](#) [GBL10-E3/45](#) [GBU10J-BP](#) [GBU4J-BP](#) [GBU4K-BP](#) [GBU8B-E3/45](#) [GBU8D-BP](#) [GBU8J-BP](#) [GSIB1520-E3/45](#) [MB1510](#) [MB352W](#) [MB6M-G](#) [B2M-E345](#) [B40C7000A](#) [B500C7000A](#) [MP5010W-BP](#) [MP501W-BP](#) [MP502-BP](#) [BR1005-BP](#) [BR101-BP](#) [BU1006-E345](#) [BU12065S-E3/45](#) [BU1508-E3/51](#) [BU2006-E3/45](#) [BU2008-E345](#)