

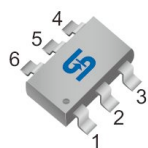

SOT-26



Pin Definition:

1. VCC
2. Ground
3. Output
4. Dimming
5. Compensation
6. Current Sense

Description

The TS19702 is a highly-integrated, low startup current, average current mode, one cycle control PFC and fixed switching frequency PWM controller. These functions enable the LED driver to easily meet the accuracy average LED current and high power factor requirements. The integrated functions also include the LED short protection, open protection, and internal over temperature protection. The COMP pin controls the duty by connected an RC compensation network to ground and forming the closed loop feedback control. To protect the external power MOSFET from being damaged by supply over voltage, the TS19702 Output pin voltage is clamped to about 15V.

Features

- High Power Factor by One Cycle Control
- Accuracy Constant Current
- Low BOM Cost
- Linear Dimming on DIM Pin
- Average Current / Fixed Frequency Control
- Gate Output Voltage Clamp
- LED Open Protection (OVP)
- LED Short Protection (SCP)
- Over Current Protection (OCP)
- Internal OTP Protection
- 300mA Driving Capability for Output Pin
- Application voltage range: $80V_{AC} \sim 308V_{AC}$

Application

- E27, T5, T8 LED lighting
- LED Lighting Applications

Ordering Information

Part No.	Package	Packing
TS19702CX6 RFG	SOT-26	3kpcs / 7" Reel

Note: "G" denote for Halogen Free Product

Absolute Maximum Ratings (Ta = 25°C unless otherwise noted)

Parameter	Symbol	Limit	Unit
Supply Voltage	V_{CC}	30	V
Compensation Voltage	V_{COMP}	-0.3 ~ 7	V
Dimming Pin	V_{DIM}	-0.3 ~ 7	V
Current Sense Pin	V_{CS}	-0.3 ~ 7	V
Output Pin	V_{OUT}	15	V
Power Dissipation @ $T_A=85^\circ\text{C}$	P_D	250	mW
Operating Ambient Temperature	T_{OPR}	-20 ~ +85	°C
Junction Temperature	T_J	+150	°C
Storage Temperature Range	T_{STG}	-65 ~ +150	°C
Thermal Resistance - Junction to Ambient	$R\theta_{JA}$	250	°C/W
ESD Voltage Protection	HBM	2	KV
	MM	200	V

Electrical Characteristics ($V_{CC}=15$, $T_A=25^{\circ}\text{C}$, unless otherwise specified.)

Parameter	Symbol	Min.	Typ.	Max.	Unit
Supply Voltage					
Startup Current ($V_{CC}=\text{UVLO on} - 1\text{V}$)	I_{START}	--	8	15	μA
Operating Current (with 1nF load on OUT pin), $V_{\text{comp}} = 2.5\text{V}$	I_{OPR}	--	2	3	mA
Operating Current (with 1nF load on OUT pin), Protection Tripped (OCP, OVP, SCP, OTP)	I_{OPR}	--	0.7	1	mA
UVLO(off)	UVLO_{OFF}	7	8	9	V
UVLO(on)	UVLO_{ON}	14	15	16	V
OVP Level on V_{CC} Pin	V_{OVP}	26.5	28	29.5	V
OVP De-Bounce Time	T_{OVP}	--	40	--	μs
Voltage Feedback					
Feedback Reference Voltage	V_{FB}	0.196	0.200	0.204	V
Tran-Conductance		--	120	--	μs
Output Sink Current	I_{SINK}	--	12	--	μA
Output Source Current	I_{SOURCE}	--	12	--	μA
Current Sensing					
Input Over Voltage Protection	$V_{\text{IN-PROTECT}}$	0.7	0.80	0.9	V
Open Loop Voltage, CS Pin Open	V_{CS}	--	5	--	V
Leading-Edge Blanking Time	T_{LE}	--	410	--	ns
Delay to Output	$T_{\text{O-DELAY}}$	--	100	220	ns
Switching Frequency					
Switching Frequency	F_{SW}	42	45	48	KHz
Maximum Duty	$D_{(\text{MAX})}$	90	--	--	%
Frequency Jitter Range		--	+/-4	--	%
Temp. Stability ($-40^{\circ}\text{C} \sim 125^{\circ}\text{C}$)	TEMP_{STB}	--	--	6	%
Voltage Stability ($V_{CC} = 11\text{V} \sim 25\text{V}$)	V_{STB}	--	--	1	%
GATE DRIVER OUTPUT					
Rising Time, Load Capacitance = 1000pF	T_{RISING}	--	160	320	ns
Falling Time, Load Capacitance = 1000pF	T_{FALLING}	--	80	160	ns
VGATE-Clamp ($V_{CC}=25\text{V}$)	V_{GATE}	--	13.5	15	V
DIM INPUT SECTION					
Saturation Threshold Voltage	SAT_{TH}	3.0	--	--	V
Linear Dimming Range	DIM	0.3	--	3.0	V
LED Current off Threshold Voltage	IOFF_{TH}	--	--	0.3	V
Current Source	CS	290	300	310	μA
OTP SECTION					
OTP Trip Point	OTP_{TP}	140	150	160	$^{\circ}\text{C}$
OTP Release Point	OTP_{RP}	120	130	140	$^{\circ}\text{C}$
OTP Threshold Level	OTP_{TH}	--	20	--	$^{\circ}\text{C}$
OTP De-Bounce Time	OTP_{DBT}	40	80	120	μs

Note 1: OCP, SCP, OTP: Auto Recovery Type

Note 2: OVP, Auto Recovery Type (Latch off type optional)

Function Block

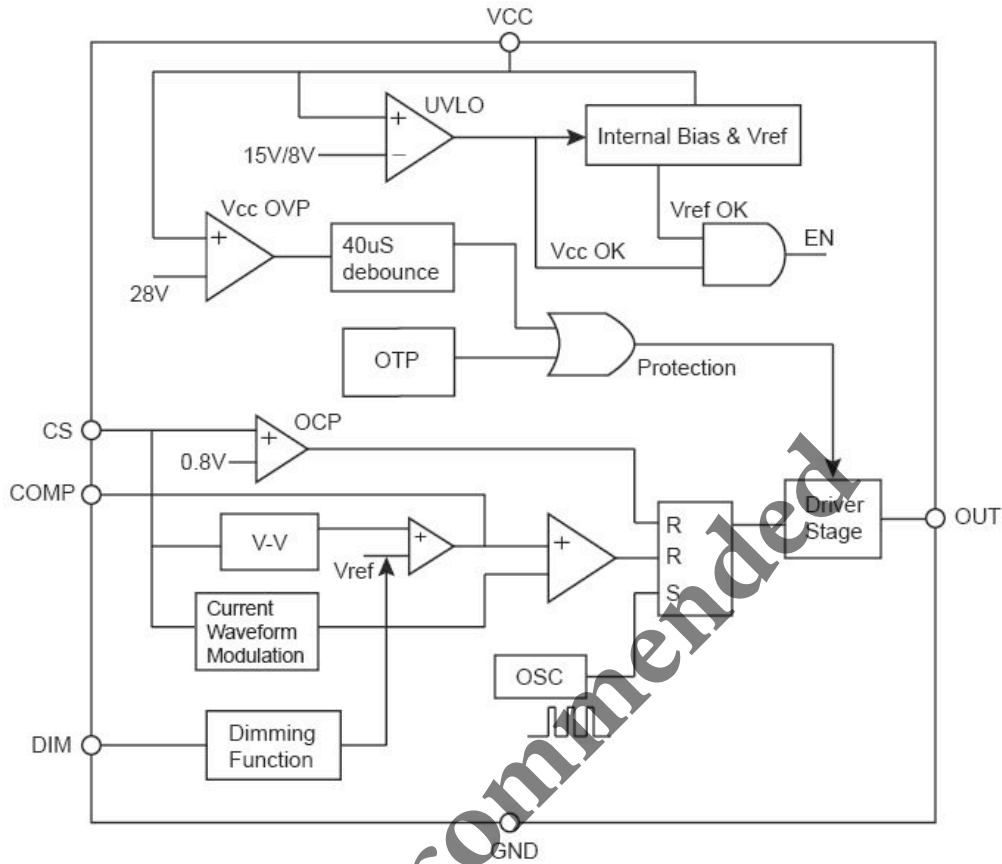

Pin Description

Pin No.	Name	Function
1	VCC	Power supply pin
2	GND	Ground pin
3	OUT	The output driver for driving the external MOSFET
4	DIM	Dimming control pin by input a DC voltage
5	COMP	Feedback compensation network
6	CS	Current sense pin, connect to sense the MOSFET current

Application Circuit

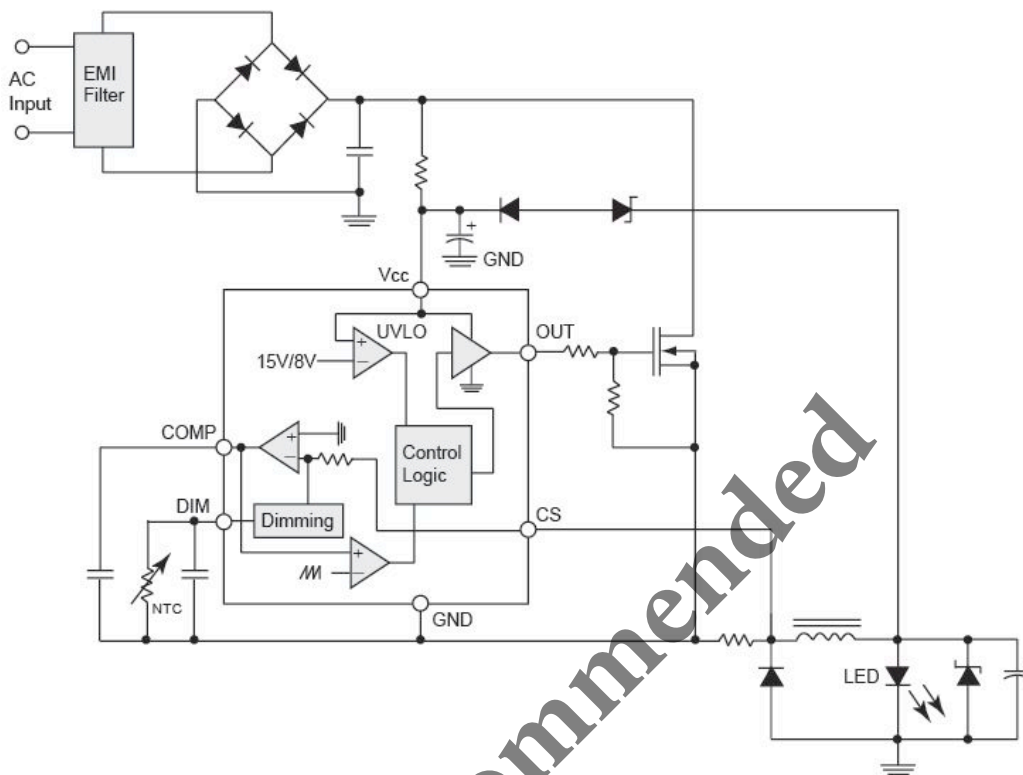

Application Information

Start-up Current

The typical start-up current is around 8 μ A. Very low start-up current allows the PWM controller to increase the value of start-up resistor and then reduce the power dissipation on it.

UVLO (Under Voltage Lockout)

A hysteresis UVLO comparator is implemented in TS19702, then the turn-on and turn-off thresholds level are fixed at 15V and 8V respectively. This hysteresis shown in Fig.11 ensures that the start-up capacitor will be adequate to supply the chip during start-up. For quickly startup the LED driver, the start-up resistor should be matched with the startup capacitor. Due to the low UVLO on level, so the turn-on delay time will also never greater than the general PWM IC.

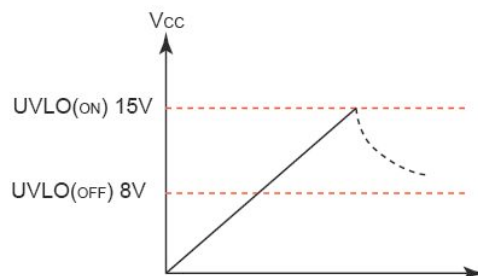

Oscillator

The maximum duty-cycle of internal oscillator is up to 90% for driving high LED voltage string. The frequency of the oscillator is fixed to 45KHz by internal setting.

LEB (Leading-Edge Blanking)

Each time the power MOSFET is switched on, a turn-on spike will inevitably occur at the sense resistor. To avoid fault trigger, a 410ns leading-edge blanking time is built in. Conventional RC filtering can therefore be omitted. During this blanking period, the current-limit comparator is disabled and can not switch off the gate driver.

Application Information (Continue)

OCP (Over Current Protection)

The TS19702 has an over current protection function on CS pin. An internal circuit detects the current level, when the current is larger than a threshold level, the gate output will keep on low level. Then V_{CC} decreases below UVLO off level, the controller resets again.

OVP (Over Voltage Protection) on VCC

To prevent the LED driver from being damaged, the TS19702 is implemented an OVP function on VCC. When the VCC voltage is higher than the OVP threshold voltage 28V, the output gate driver circuit will be shut down immediately to stop the switching of power MOSFET. The V_{CC} pin OVP function is an auto recovery type protection (latch off type optional). If the OVP condition happens, the pulses will be stopped and never recovery unless the V_{CC} pin voltage is down to the UVLO off level. The TS19702 is working in an auto-recovery mode as shown in below figure

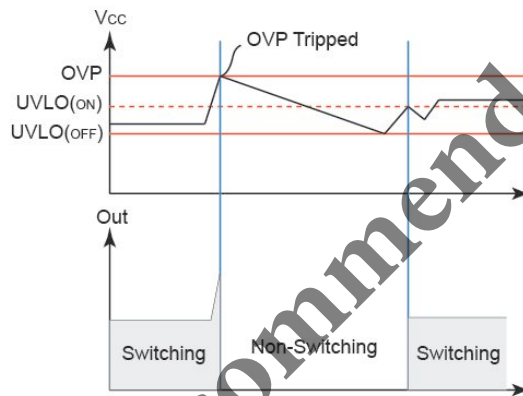

Gate Clamp/Soft Driving

Driver is clamped to 15V by an internal clamping circuit. Those damages usually come from undesired over-voltage gate signals. Under the conditions listed below, the gate output will turn off immediately to protect the power circuit. The TS19702 also has soft driving function to minimize EMI.

Over Temperature Protection/Dimming Function

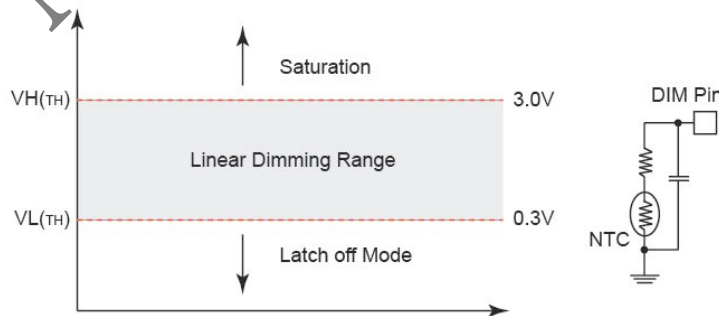

The typical application for DIM pin is shown in above Fig. The NTC thermistor is setting as an external OTP protection. In the DIM pin, there is one comparator for latch-off mode protection. While the voltage on this pin is lower than 0.3V, the TS19702 will shut down. When the voltage is in the range of 0.3 to 3.0V, the TS19702 is operating on the linear dimming range. While the voltage is higher than 3.0V, the TS19702 is operating on the normal status. It also could let this Pin open when the function is not required for the user.

Electrical Characteristics Curve

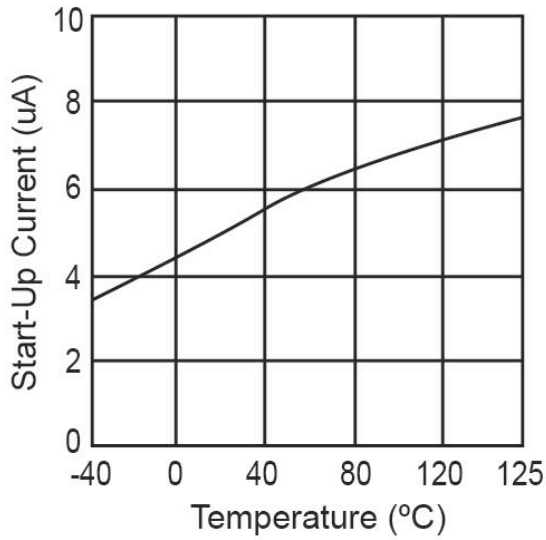

Figure 1. Star-Up current vs. Temperature

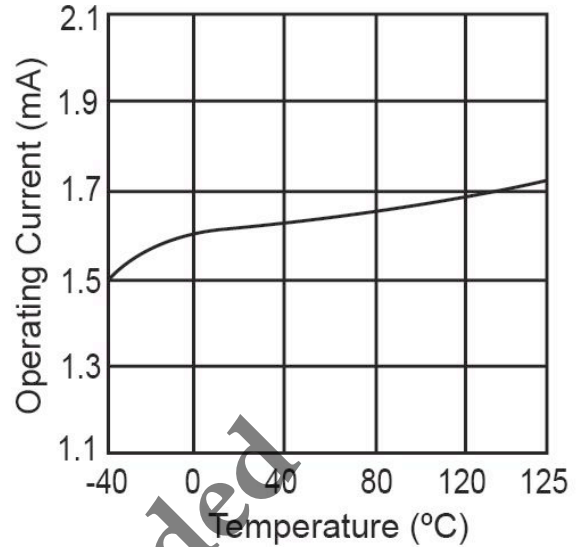

Figure 2. Operating Current vs. Temperature

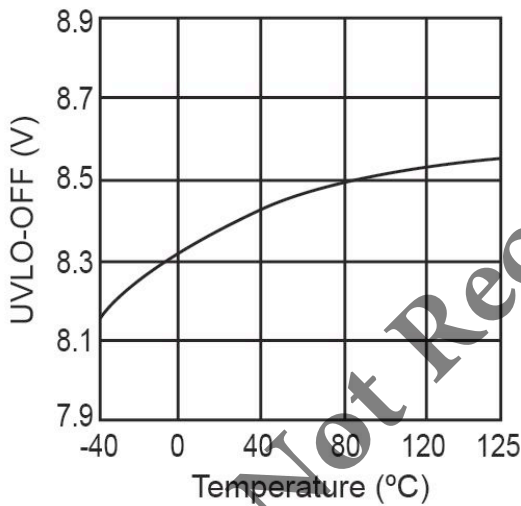

Figure 3. UVLO-OFF vs. Temperature

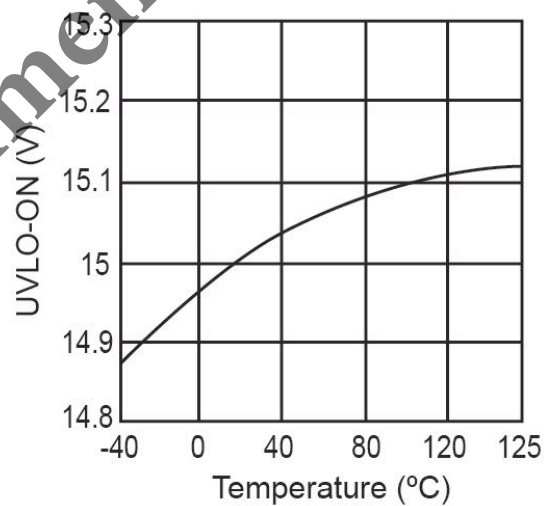

Figure 4. UVLO-ON vs. Temperature

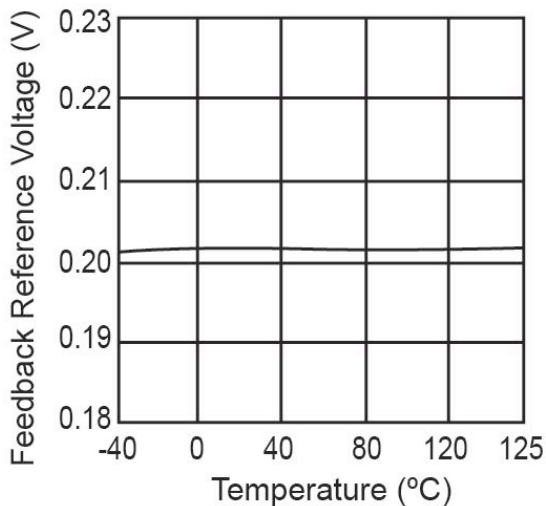

Figure 5. FB V_{REF} vs. Temperature

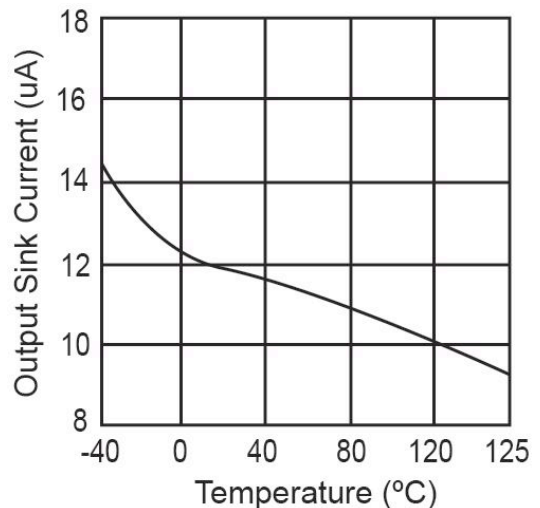

Figure 6. Output Sink Current vs. Temperature



Electrical Characteristics Curve

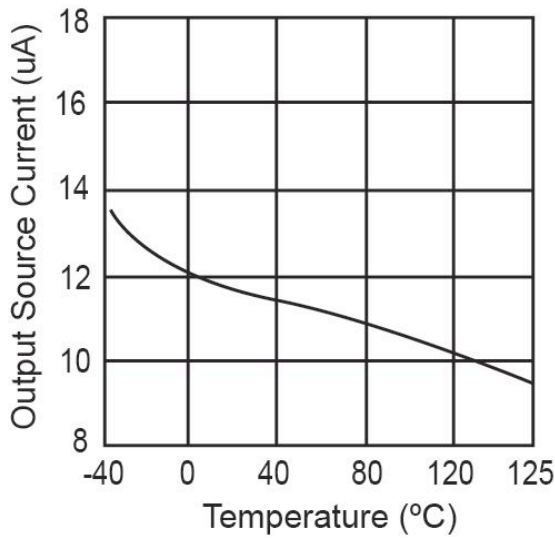

Figure 7. Output Source Current vs. Temp.

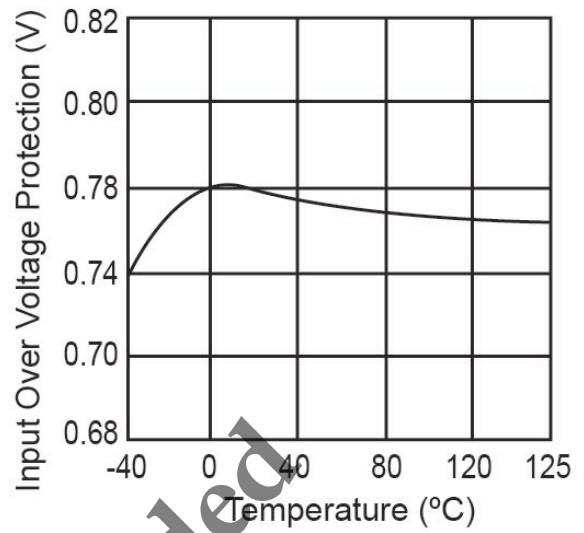

Figure 8. Input Over Voltage vs. Temperature

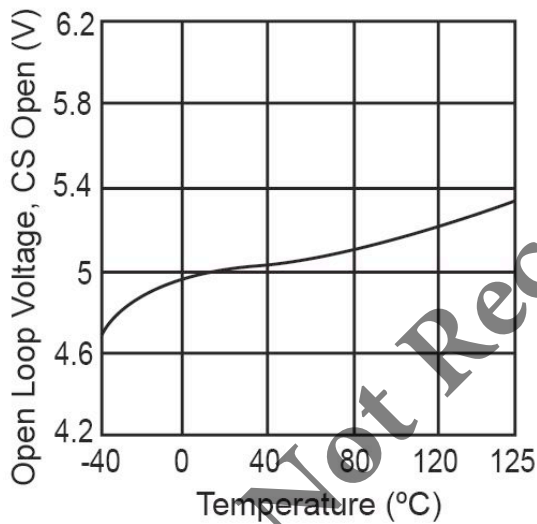

Figure 9. Open Loop Voltage vs. Temperature

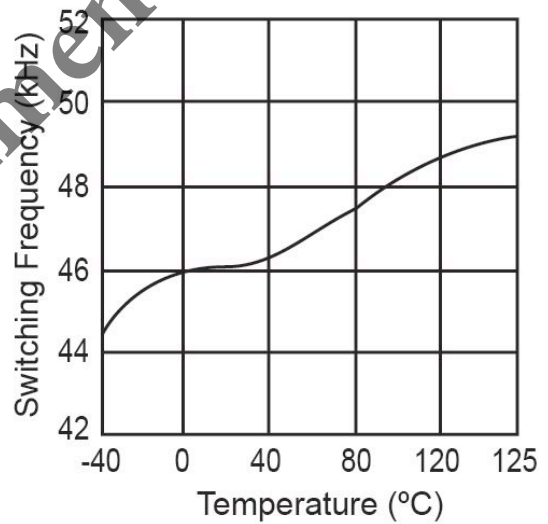
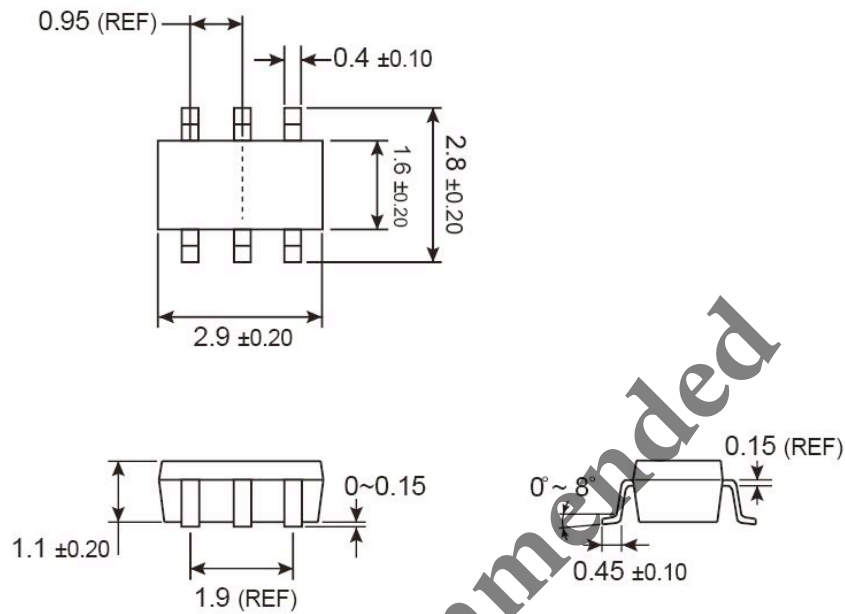

Figure 10. Switching Frequency vs. Temp.

SOT-26 Mechanical Drawing



Unit: Millimeters

Marking Diagram

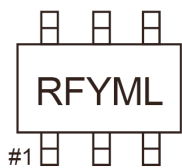

- RF** = Device Code
- Y** = Year Code (2=2012, 3=2013, 4=2014.....)
- M** = Month Code for Halogen Free Product
(**O**=Jan, **P**=Feb, **Q**=Mar, **R**=Apr, **S**=May, **T**=Jun, **U**=Jul, **V**=Aug, **W**=Sep, **X**=Oct, **Y**=Nov, **Z**=Dec)
- L** = Lot Code

Not Recommended

Not Recommended

Notice

Specifications of the products displayed herein are subject to change without notice. TSC or anyone on its behalf, assumes no responsibility or liability for any errors or inaccuracies.

Information contained herein is intended to provide a product description only. No license, express or implied, to any intellectual property rights is granted by this document. Except as provided in TSC's terms and conditions of sale for such products, TSC assumes no liability whatsoever, and disclaims any express or implied warranty, relating to sale and/or use of TSC products including liability or warranties relating to fitness for a particular purpose, merchantability, or infringement of any patent, copyright, or other intellectual property right.

The products shown herein are not designed for use in medical, life-saving, or life-sustaining applications. Customers using or selling these products for use in such applications do so at their own risk and agree to fully indemnify TSC for any damages resulting from such improper use or sale.

X-ON Electronics

Largest Supplier of Electrical and Electronic Components

Click to view similar products for [LED Lighting Drivers](#) category:

Click to view products by [Taiwan Semiconductor](#) manufacturer:

Other Similar products are found below :

[LV5235V-MPB-H](#) [MB39C602PNF-G-JNEFE1](#) [FAN5701UMP20X](#) [FAN5702UMP30X](#) [MIC2871YMK-T5](#) [MP1518DJ-LF-P](#) [MP3202DG-LF-P](#) [MP3304BDD-LF-P](#) [MP3306EG-LF-P](#) [MP3398AGY](#) [MP4033GK](#) [AL1676-10BS7-13](#) [AL1676-20AS7-13](#) [MX877RTR](#)
[NCL30085BDR2G](#) [ICL8201](#) [IS31BL3506B-TTLS2-TR](#) [PAM2841GR](#) [A8519KLPTR-T](#) [FAN5701UMP08X](#) [FAN5702UMP20X](#) [AL3157F-7](#)
[AL8807BQMP-13](#) [LV52204MTTBG](#) [MP2488DN-LF](#) [MP24893DQ-LF-P](#) [MP24894GJ-P](#) [MP24895GJ-P](#) [MP3308DL-LF-Z](#) [MP3393EF-LF](#)
[MP3394SGF](#) [MP3802DQ-LF-P](#) [MP4008GS](#) [MP4031GS](#) [MP4032-1GS](#) [MP4034GS](#) [MP46885DN-LF](#) [SLG7NT4082V](#) [SLG7NT4082VTR](#)
[PCA9955BTWQ900J](#) [TLD5095EL](#) [LED6001TR](#) [STP4CMPQTR](#) [BD1604MVV-E2](#) [MC10SX1130DG](#) [MAX16832CASAT](#)
[MAX16814CATP+](#) [NCL30086BDR2G](#) [NCL30088BDR2G](#) [IS31LT3350-V1SDLS2-EB3CH](#)